

W1 Clamp arm

W2 Clamp arm

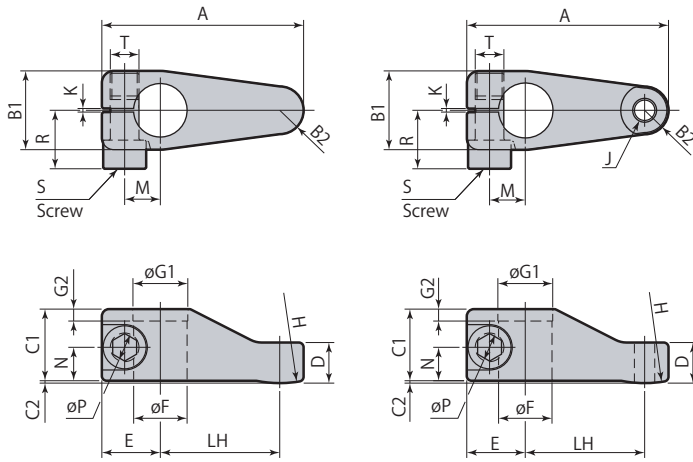

Material : SCM440 (Refining HB285-344)

WL Clamp arm

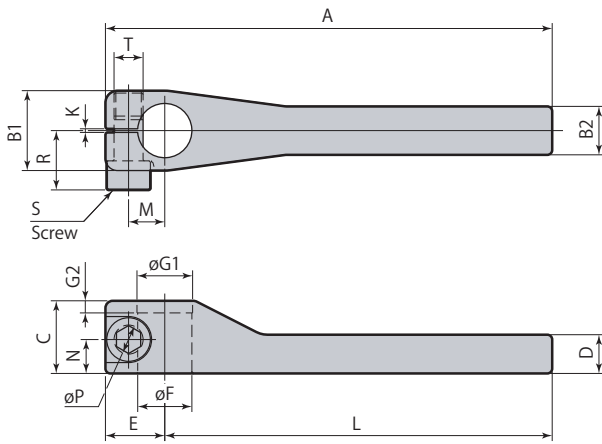

Material : SCM440 (Refining HB285-344)

Screw

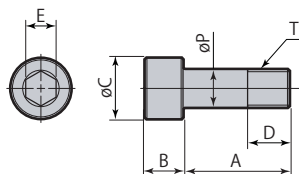

mm

Clamp arm	CTH06-W□	CTH10-W□	CTH16-W□	CTH25-W□
A	64.5	84.5	98	113
B1	24	33	43	49
B2	7	10	11	15
C1	21	30	32	35
C2	0.5	1	1	1.5
D	12.5	17	21	21.5
E	17.5	24.5	30	33
øF	16 ^{+0.003} _{-0.015}	22.4 ^{+0.004} _{-0.017}	30 ^{+0.004} _{-0.017}	32 ^{+0.005} _{-0.020}
øG1	-	23	-	33
G2	-	5	-	6
H	50	50	60	75
J	M8×1.25	M10×1.5	M10×1.5	M12×1.75
K	2	2	2	2
LH	40	50	57	65
M	10.5±0.1	15±0.1	19±0.1	20.5±0.1
N	10	14	15	16
øP	8 ^{+0.015} ₀	12 ^{+0.018} ₀	14 ^{+0.018} ₀	16 ^{+0.018} ₀
R	16.5	24.5	29.5	34.5
S (screw)	CTH06-VB	CTH10-VB	CTH16-VB	CTH25-VB
T	M8×1.0	M12×1.5	M14×1.5	M16×1.5
Mass	0.13 kg	0.33 kg	0.52 kg	0.78 kg
Swing clamp	CTW06 CTV06	CTW10 CTV10	CTW16 CTV16	CTW25 CTV25

mm

Clamp arm	CTH06-WL	CTH10-WL	CTH16-WL	CTH25-WL
A	152.5	184.5	200	213
B1	24	33	43	49
B2	14	20	22	30
C	21	30	32	35
D	12	16	20	20
E	17.5	24.5	30	33
øF	16 ^{+0.003} _{-0.015}	22.4 ^{+0.004} _{-0.017}	30 ^{+0.004} _{-0.017}	32 ^{+0.005} _{-0.020}
øG1	-	23	-	33
G2	-	5	-	6
K	2	2	2	2
L	135	160	170	180
M	10.5±0.1	15±0.1	19±0.1	20.5±0.1
N	10	14	15	16
øP	8 ^{+0.015} ₀	12 ^{+0.018} ₀	14 ^{+0.018} ₀	16 ^{+0.018} ₀
R	16.5	24.5	29.5	34.5
S (screw)	CTH06-VB	CTH10-VB	CTH16-VB	CTH25-VB
T	M8×1.0	M12×1.5	M14×1.5	M16×1.5
Mass	0.24 kg	0.58 kg	0.87 kg	1.25 kg
Swing clamp	CTW06 CTV06	CTW10 CTV10	CTW16 CTV16	CTW25 CTV25

mm

Screw	CTH06-VB	CTH10-VB	CTH16-VB	CTH25-VB
A	20	28	35	41
B	8	12	14	16
øC	13	18	21	24
D	9	11	13	15
E	6	10	12	14
øP	8 ^{-0.01} _{-0.05}	12 ^{-0.01} _{-0.05}	14 ^{-0.01} _{-0.05}	16 ^{-0.01} _{-0.05}
T	M8×1.0	M12×1.5	M14×1.5	M16×1.5
Swing clamp	CTW06 CTV06	CTW10 CTV10	CTW16 CTV16	CTW25 CTV25

Clamp arm is not included. Manufacture a clamp arm with the dimensions shown in the table below.

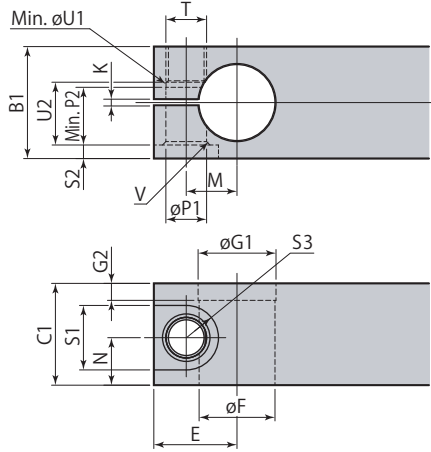

mm

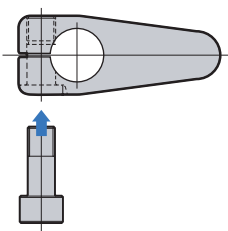

- Install mounting screws for arm from direction shown in left diagram viewed from top. Installation from the opposite direction can cause loosened screws and resultant broken rod.

Swing clamp	CTW06 CTV06	CTW10 CTV10	CTW16 CTV16	CTW25 CTV25
B1	24	33	43	49
C1	21	30	32	35
E	17.5	24.5	30	33
øF	16 ^{+0.003} _{-0.015}	22.4 ^{+0.004} _{-0.017}	30 ^{+0.004} _{-0.017}	32 ^{+0.005} _{-0.020}
øG1	—	23	—	33
G2	—	5	—	6
K	2	2	2	2
M	10.5±0.1	15±0.1	19±0.1	20.5±0.1
N	10	14	15	16
øP1	8 ^{+0.015} ₀	12 ^{+0.018} ₀	14 ^{+0.018} ₀	16 ^{+0.018} ₀
P2	11	17	22	26
S1	14	19	22	25
S2	3.5	4	6	6
S3	7	9.5	11	12.5
T	M8×1.0	M12×1.5	M14×1.5	M16×1.5
øU1	7.9	11.9	13.9	15.9
U2	12.5	18.5	23.5	27.5
V	C1	C1	C1.5	C1.5

Caution in use

Mounting & dismounting of clamp arm

Swing clamp may be damaged if excessive torque is applied to piston rod, since structure is intended for swinging using cam mechanism with lead grooves.

Loosen screw (CTH□-VB) before mounting or dismounting clamp arm, or adjusting position of clamp arm, to prevent excessive rotating torque from being applied on piston rod.

Refer to table below for screw tightening torque.

Swing clamp	Thread size	Tightening torque
CTW06, CTV06	M 8	30 N·m
CTW10, CTV10	M12	100 N·m
CTW16, CTV16	M14	150 N·m
CTW25, CTV25	M16	240 N·m

Swing speed adjustment

Too fast swinging speed of clamp arm can cause malfunction. Adjust speed using flow control valve with check valve to set the swing time equal to or higher than the shortest swing time shown in the table below. Clamp stroke (perpendicular descend) time is not included in 90° swing time.

Swing clamp	Shortest swing time	Max. flow rate	
		Clamping side	Unclamping side
CTW06, CTV06	0.3 s	0.43 L/min	0.91 L/min*
CTW10, CTV10	0.3 s	1.23 L/min	2.41 L/min*
CTW16, CTV16	0.4 s	1.48 L/min	3.39 L/min*
CTW25, CTV25	0.4 s	2.70 L/min	5.60 L/min*

*: Only for the double-acting model CTW

Moment of inertia for clamp arm

Too large moment of inertia for clamp arm can also cause malfunction. When fabricating the clamp arm, determine a proper shape which provides moment of inertia smaller than the maximum moment of inertia shown in the table below.

Swing clamp	Max. moment of inertia
CTW06, CTV06	1.6×10 ⁻³ kg·m ²
CTW10, CTV10	5.1×10 ⁻³ kg·m ²
CTW16, CTV16	8.5×10 ⁻³ kg·m ²
CTW25, CTV25	1.4×10 ⁻² kg·m ²

Moment of inertia for option clamp arm (reference)

Clamp arm models		Moment of inertia
Standard type	CTH06-W1, CTH06-W2	6.1×10 ⁻⁵ kg·m ²
	CTH10-W1, CTH10-W2	2.6×10 ⁻⁴ kg·m ²
	CTH16-W1, CTH16-W2	5.5×10 ⁻⁴ kg·m ²
	CTH25-W1, CTH25-W2	1.14×10 ⁻³ kg·m ²
Long type	CTH06-WL	1.1×10 ⁻³ kg·m ²
	CTH10-WL	3.5×10 ⁻³ kg·m ²
	CTH16-WL	5.8×10 ⁻³ kg·m ²
	CTH25-WL	9.5×10 ⁻³ kg·m ²