

## Expansion clamp for workpiece transfer unit

The gripper to grasps the workpiece is no longer required, which can realizes lightweight and downsized workpiece transfer unit resulting in selection one size smaller robot.

### Downsize & weight reduction of workpiece transfer unit

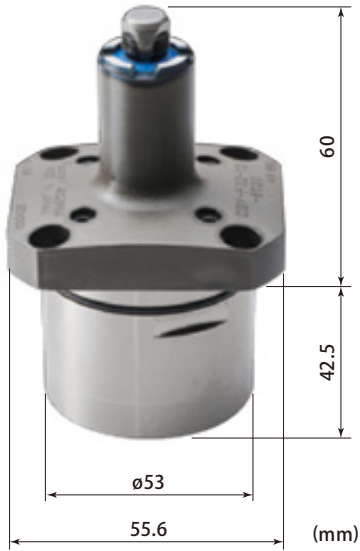

Expansion clamp  
CGY-F3

(Spring clamp / Air unclamp)

Clamping force 0.75 kN    Mass 0.97kg

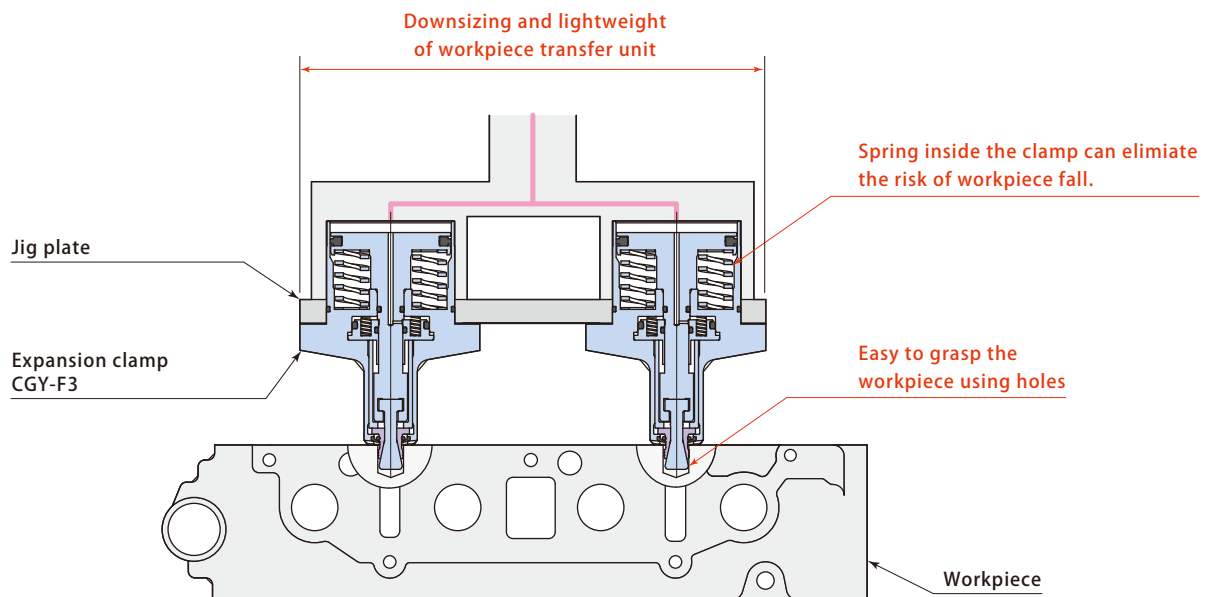
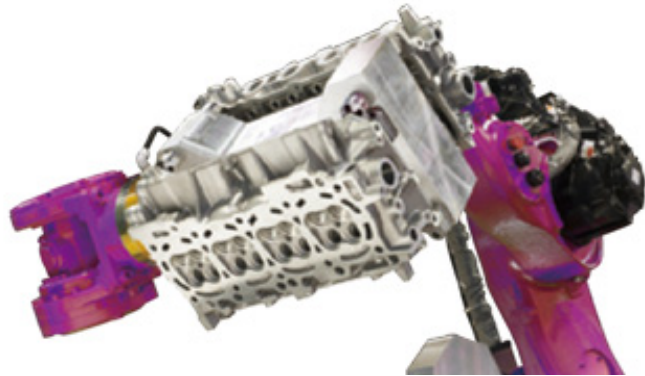

## Expansion clamp

As workpiece is grasped using the holes, by means of unifying the diameter and position of the holes on workpiece, a common jig plate can be used for various shape and size of the workpiece (No need to prepare multiple jig plate).

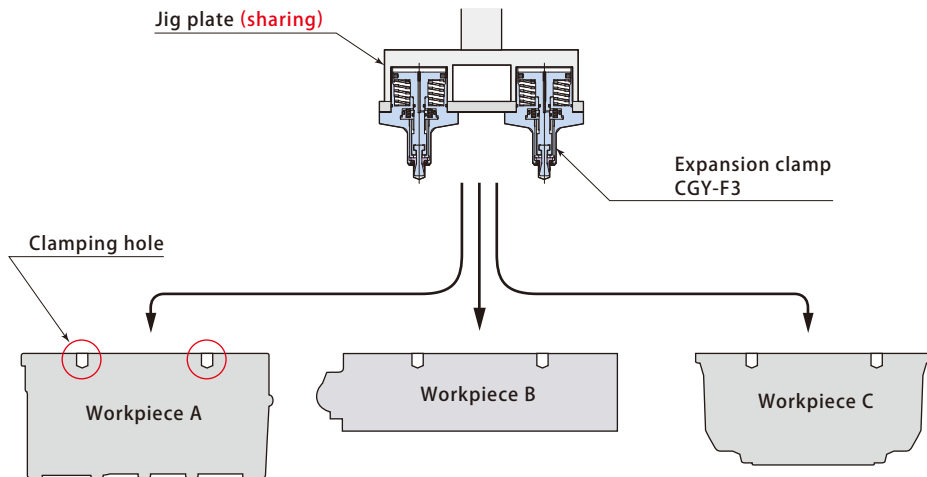

The expansion clamp which clamps upper surface of the workpiece has no need for handling space of gripper to grasp the workpiece, therefore the space for carrier pallet can be optimized and the transport cost can be reduced.

