

Realization of considerably lightweight and compact robot

The introduction of Gas balancer allows the downsize the robot and design a free stroke length and capacity.
The gas balancer with low spring constant reduces the burden on machine.

Weight reduction, High speed, Downsizing of robot



Robot N₂ gas balancer

Model		DNA3000-200
Max. charging pressure	MPa	15
Operating temperature	°C	0 ~ 70
Compressibility		1.62
Mass	kg	12.6

Robot N₂ gas balancer

Structure

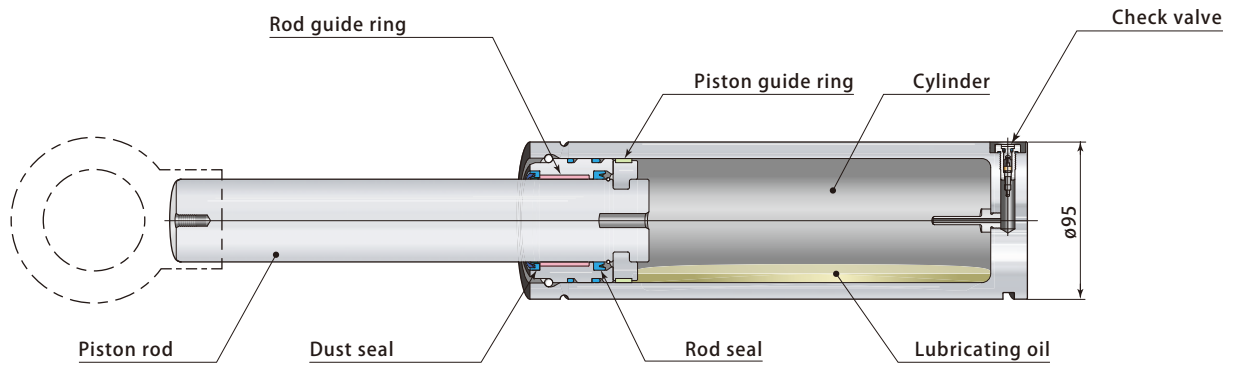

Gas balancer vs Coil spring

Robot gas balancer

Coil spring

