

model RHA160 Payload 160 kg

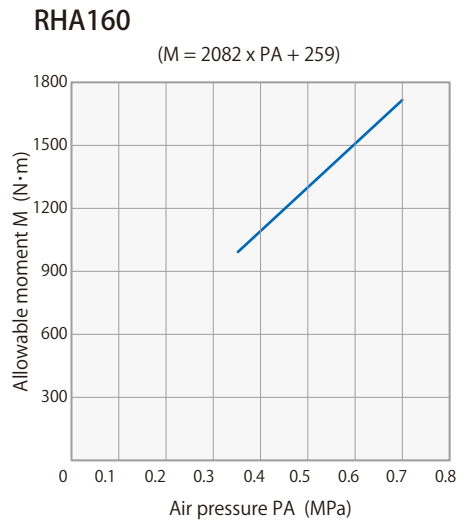

Performance diagram



Specifications

Model		RHA160	
Payload*1	kg	160	
Allowable moment (Air pressure at 0.5 MPa)*2	N·m	1300	
Allowable torque*2	N·m	900	
Tightening force	Air pressure at 0 MPa	kN	3.27
	Air pressure at 0.5 MPa	kN	16.41
Lift force	Air pressure at 0.5 MPa	kN	3.01
Repeatability	mm	0.01	
Dimensions (Outer diameter × Height when connected)	mm	177 × 88.5	
Mass	Master plate	g	5600
	Tool plate	g	2800
Air pressure for connecting/disconnecting operation	MPa	0.4~0.7	
Connector for air	Number of ports (Size)	8 (Rc3/8)	
	Working pressure	MPa	-0.05~1
Operating temperature	°C	0~70	

Option		Option symbol
Connector for air	Check valve model	C
	Add Rc1/8 × 2 ports	A0
Sensor for connecting / disconnecting		SN SP
Electric connector	10 points 3A / 1pc (with cable)	E0
	20 points 3A / 1pc (with cable)	E00
Circular electric connector	14 points 5A / 1pc	E4
	10 points 13A / 1pc	E5
Remote sensor*1	12 points (with cable)	RN RP R
	4 points (with cable)	RN4 RP4 R4

*1: Select a model that does not exceed the allowable torque and movement, even if it was less than the payload.
 *2: This value indicates the maximum. Select the right model so as not to exceed these values even for a split-second.

*1: Refer to the web site of the company named B & Plus for details about the remote sensor.

Model designation

Master plate	RHA 160 - M	Connector for air(option)	Sensor for connecting / disconnecting (option)	Electric connector(option)
Tool plate	RHA 160 - T			

No symbol	Non check valve	No symbol	Sensor none	No symbol	Connector None	RN	Master plate side Remote sensor (NPN output) × 12 points
C*	Check valve model	SN*	NPN output	E0*	3A × 10 points	RP	Master plate side Remote sensor (PNP output) × 12 points
A0	Add Rc1/8 × 2	SP*	PNP output	E00	3A × 20 points	R	Remote sensor of tool plate side × 12 points
* : Master plate only		* : Master plate only		E4	5A × 14 points	RN4	Master plate side Remote sensor (NPN output) × 4 points
				E5	13A × 10 points	RP4	Master plate side Remote sensor (PNP output) × 4 points
				* : Air connector A0 accepts only E0		R4	Remote sensor of tool plate side × 4 points

Dimensions

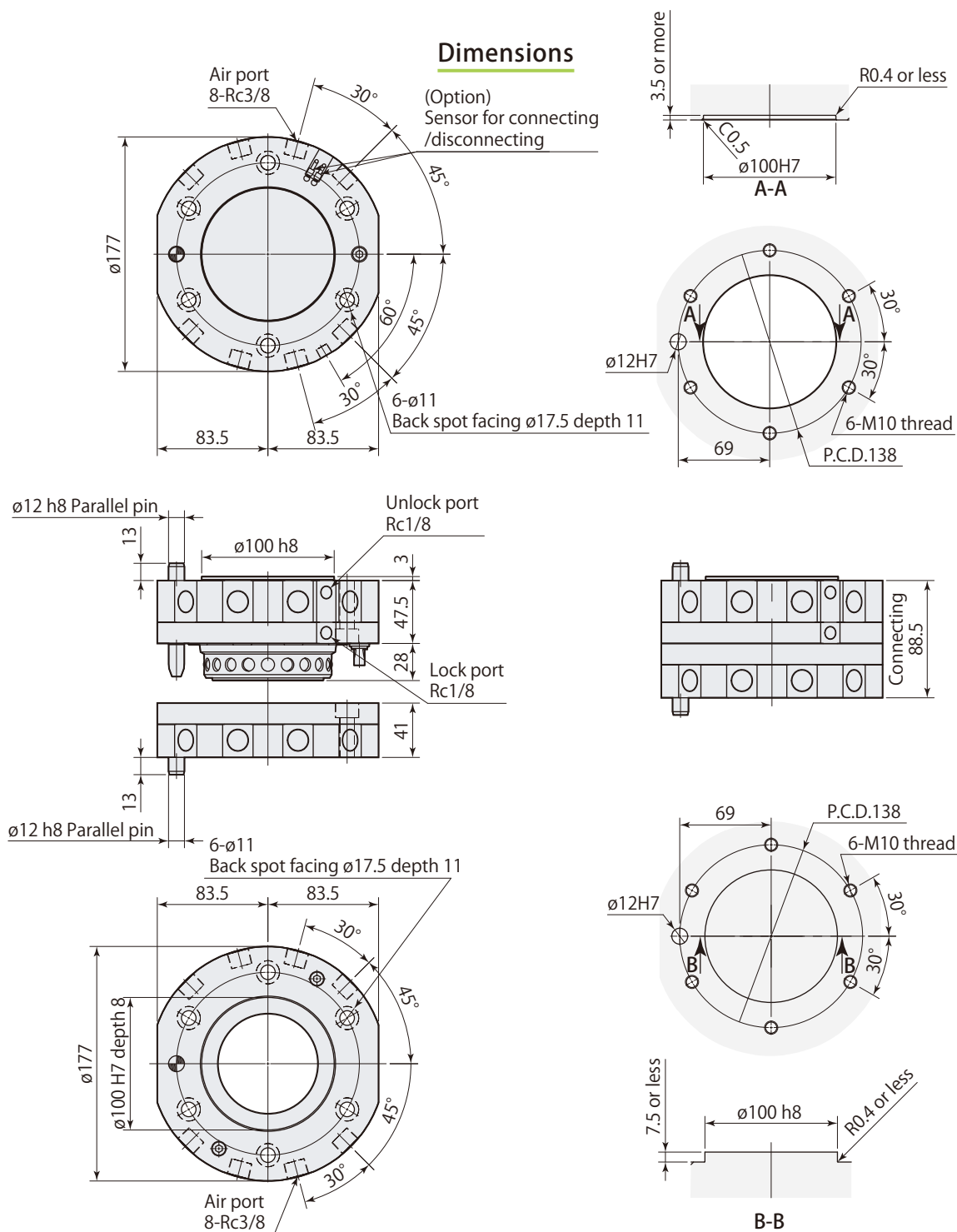

Options



Connector for air
Check valve model

Connector for air
Add Rc1/8×2

Sensor for connecting/
disconnecting

Electric connector
3A×10/20 points (with cable)

Circular electric connector
5A×14 points

Circular electric connector
13A×10 points

Remote sensor
12 points (with cable)

Remote sensor
4 points (with cable)

C

AO

Page →27

SN

NPN

SP

PNP

Page →28

E0

E00

Page →29

E4

Page →30

E5

Page →31

RN

Master plate side NPN

RP

Master plate side PNP

R

Tool plate side

Page →33

RN4

Master plate side NPN

RP4

Master plate side PNP

R4

Tool plate side

Page →33