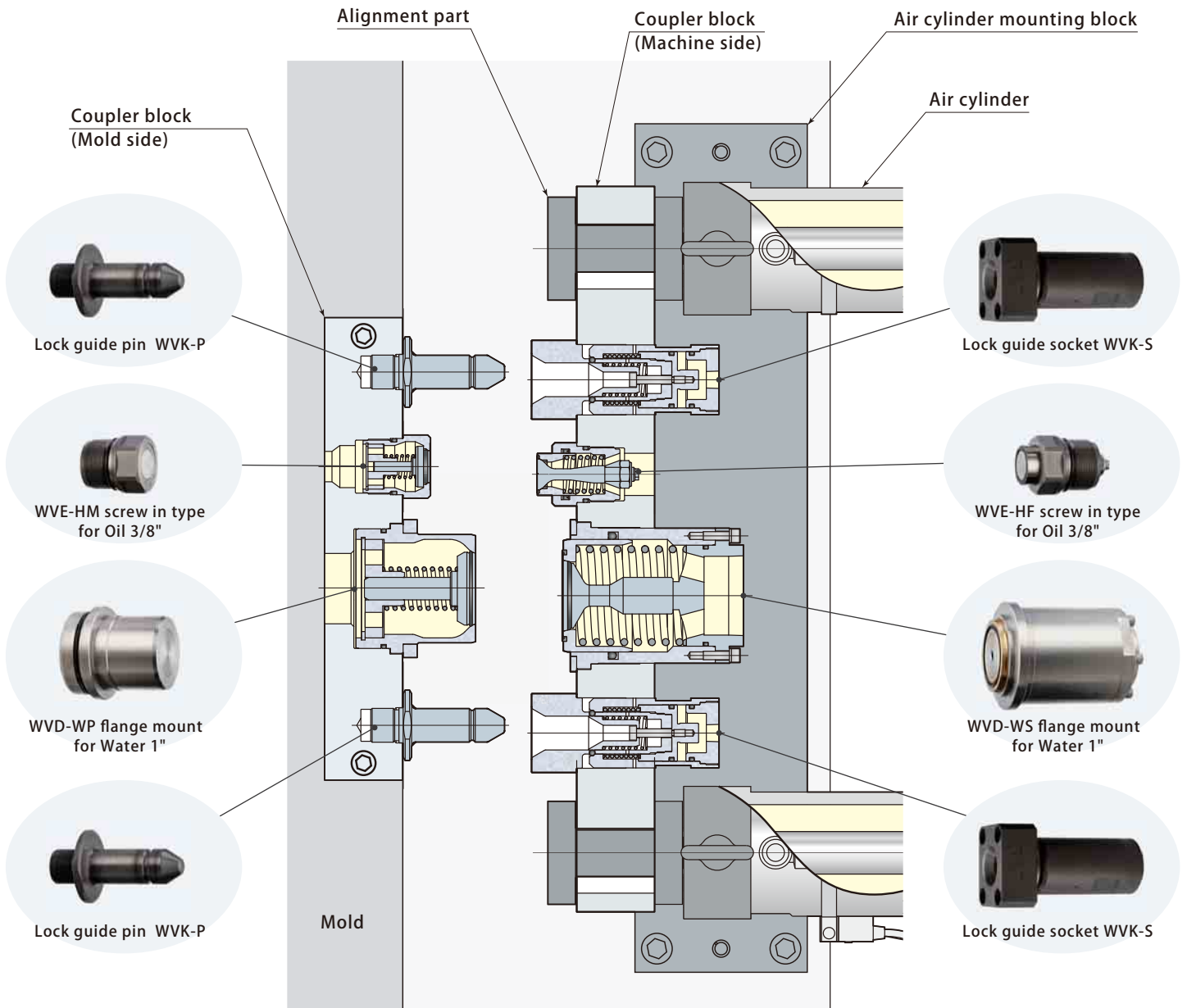

Pascal auto coupler

DATA SHEET

Pascal

auto coupler

De-coupled



Coupler module example for Mold horizontal loading

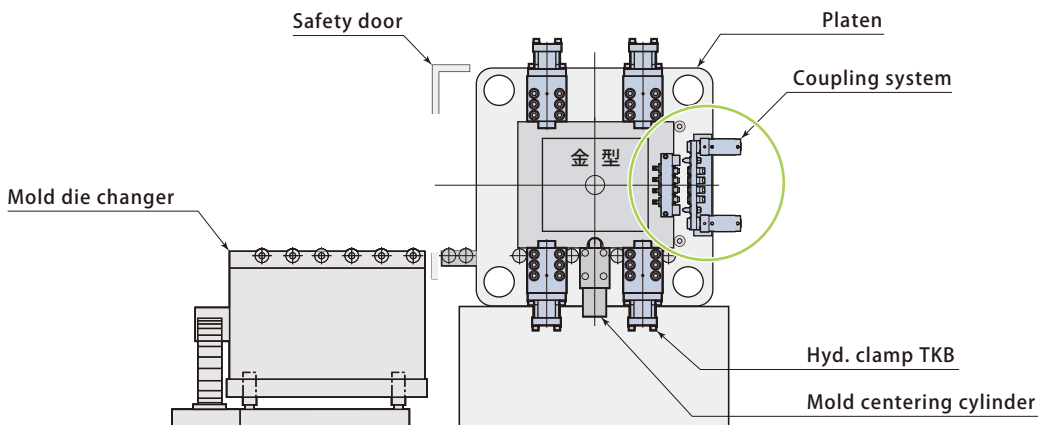

auto coupler

Coupled

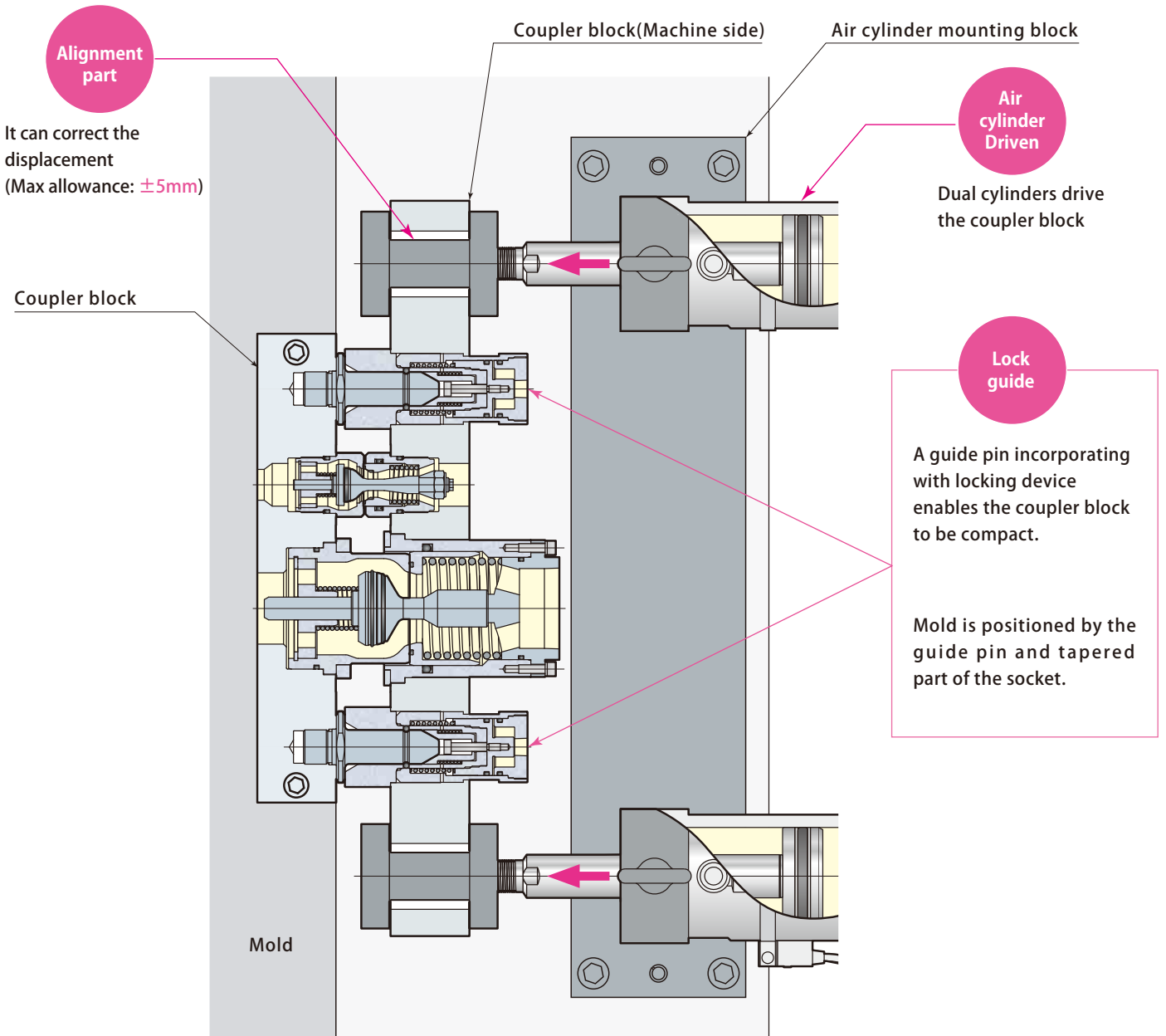

Coupler module example for Mold horizontal loading

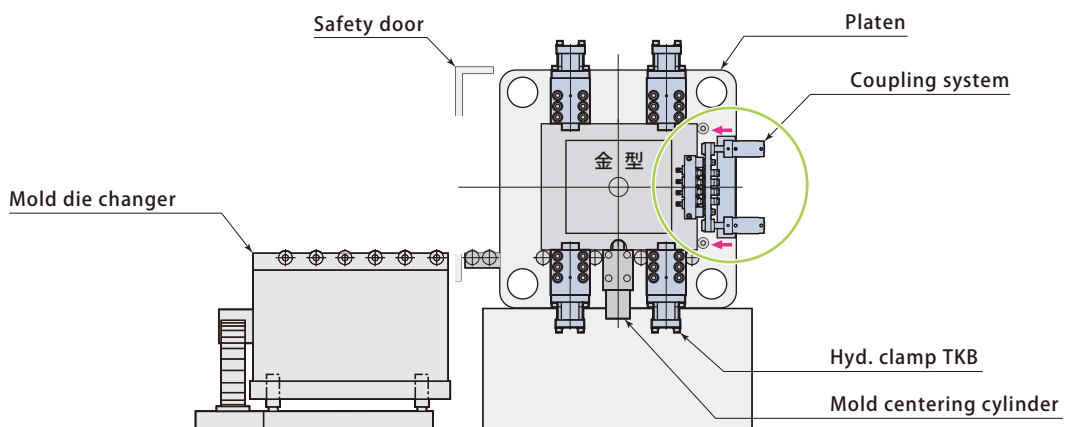

Auto coupler for Circuit diagram and flow

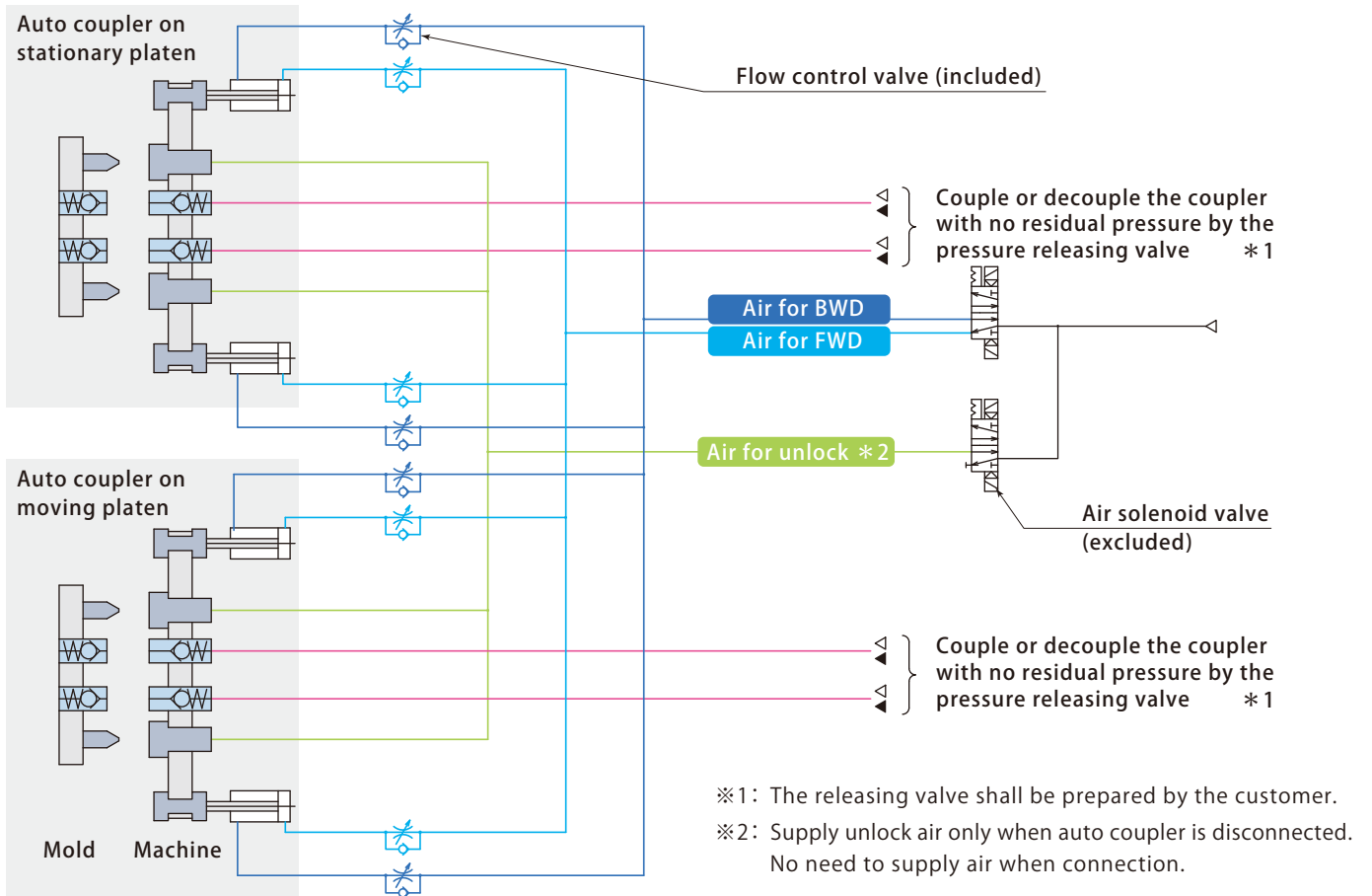

Motion	When connection	When molding	When decoupling	
Air for forward (connection)		ON		OFF
Air for backward (disconnection)		OFF		ON
Air for unlock		OFF	ON	OFF
Pressure releasing valve	open	close	open	

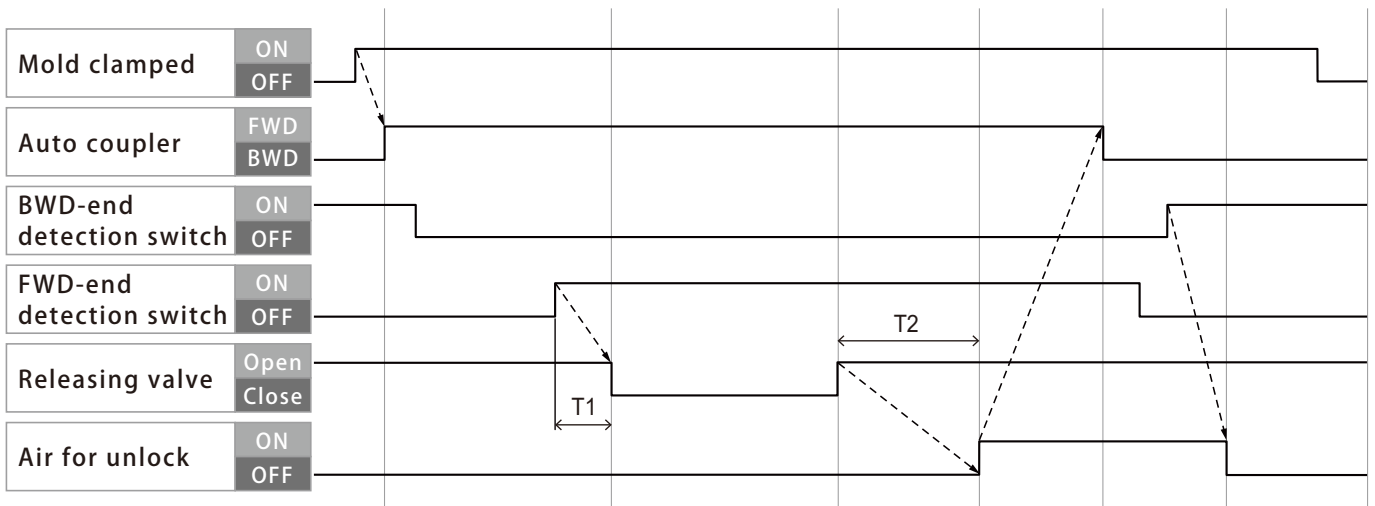

T1 : indicates the time between FWD-end detection switch ON and auto coupler connected
 (Adjust it by a timer when installation)

T2 : Indicates the time necessary to get the residual pressure down to zero. (Adjust it by a timer when installation)

Auto coupler for preliminary temperature control

Pascal coupling system can be used for water and electric connection as well.
Consult Pascal for the details.

Magnetic clamp

Auto coupler

Auto coupler for temp. control

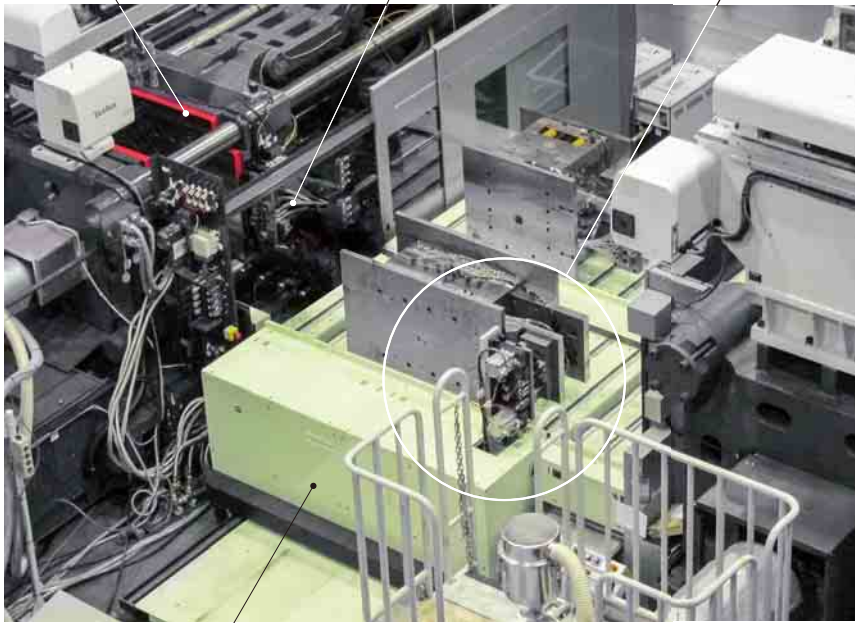

Mold die changer

Auto coupler for temp. control



Operation panel



Pascal clamp
operational buttons

Auto coupler
operational buttons

Mounting bracket



Bracket for mold side

Prepare the bracket by the customer. The bracket may be necessary even for machine side.
Consult Pascal for the details.

Pressure maintainable model (after disconnection)

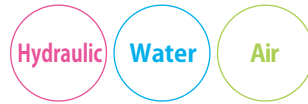

WVE 03 W M

- 1 Size
- 2 H : Hydraulic W : Water, Air
- 3 M : Mold F : Machine

- 1 Piping size
WVE03 : 3/8"
WVE06 : 3/4"

WVE - M Mold side



WVE - F Machine side

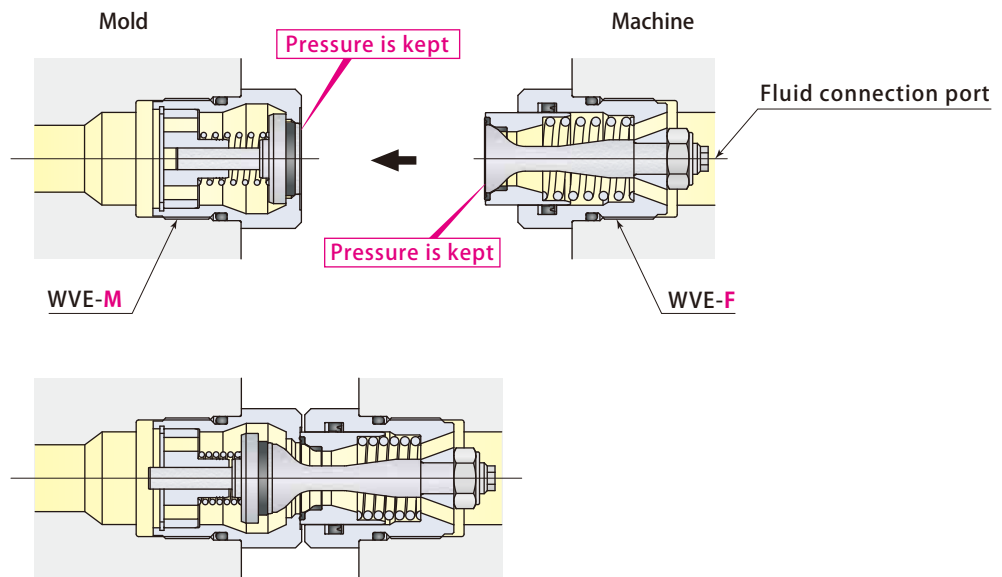

Type of fluid		General mineral-based oil		Water, compressed air		
Way of mounting		Screw mount		Screw mount		
Piping size		3/8"	3/4"	3/8"	3/4"	
Min. orifice area		mm ²	55	181	55	181
Model no.		WVE03H M/F	WVE06H M/F	WVE03W M/F	WVE06W M/F	
At coupling	Max working pressure	MPa	25	1		
	Proof pressure	MPa	37.5	1.5		
At decoupling	Max working pressure	Mold	MPa	25	1	
		Machine	MPa	14	1	
Operating temperature		°C	0 ~ 80 (No freezing)			

Non pressure maintainable model WVE-S WVE-P

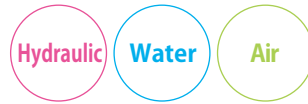

WVE 03 W P

- 1 Size
- 2 H : Hydraulic W : Water, Air
- 3 P : Mold S : Machine

- 1 Piping size
- WVE03 : 3/8"
- WVE04 : 1/2"
- WVE06 : 3/4"

WVE - P Mold side



WVE - S Machine side

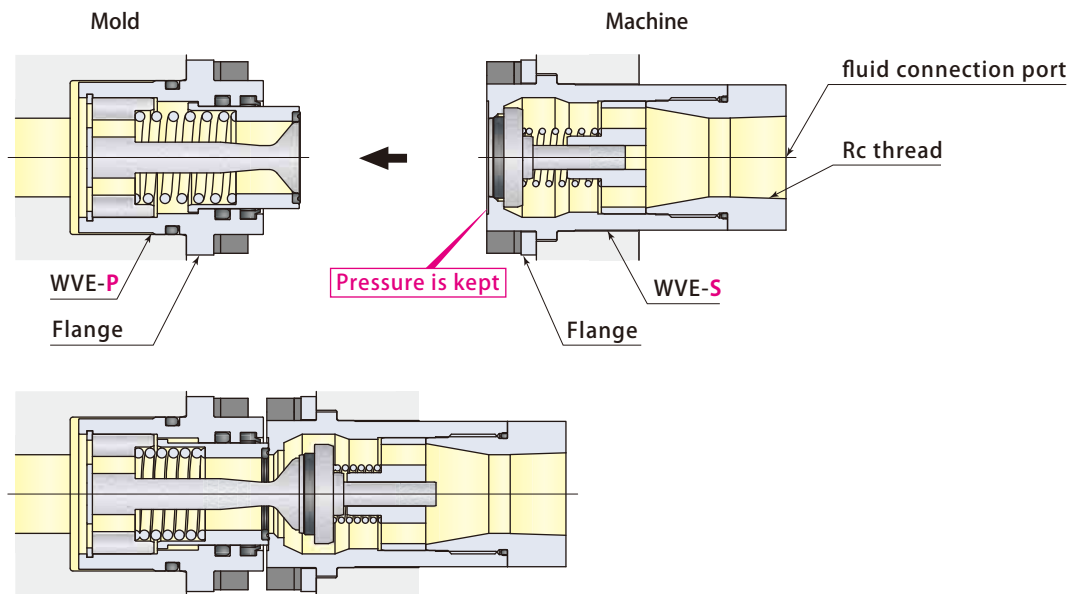

Type of fluid		General mineral-based oil			Water, compressed air		
Way of mounting		Flange			Flange		
Piping size		3/8"	1/2"	3/4"	3/8"	1/2"	3/4"
Min. orifice area	mm ²	56	100	157	56	100	157
Model no.		WVE03H P/S	WVE04H P/S	WVE06H P/S	WVE03W P/S	WVE04W P/S	WVE06W P/S
At coupling	Max working pressure	MPa 25			1		
	Proof pressure	MPa 37.5			1.5		
At decoupling	Max working pressure	Mold	MPa Pressure not maintained *No dripping		Pressure not maintained *No dripping		
		Machine	MPa 25		1		
Operating temperature		°C		0 ~ 80 (No freezing)			

Pressure maintainable model (after disconnection) for large flow rate



WVD 08 W P

1 Size
 3 P : Mold S : Machine

1 Piping size
 WVD08 : 1"
 WVD10 : 1 1/4"
 WVD12 : 1 1/2"
 WVD16 : 2"

WVD - P Mold side



WVD - S Machine side

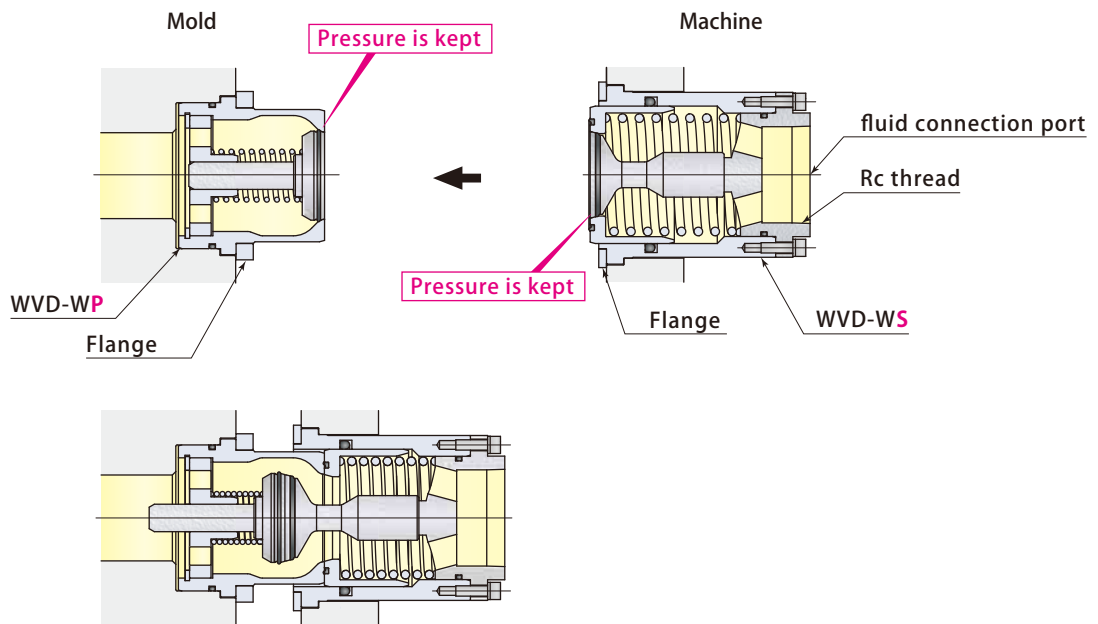

Type of fluid		Water, compressed air			
Way of mounting		Flange			
Piping size		1"	1 1/4"	1 1/2"	2"
Min. orifice area	mm ²	381	623	923	1361
Model no.		WVD08W	WVD10W	WVD12W	WVD16W
At coupling	Max working pressure	MPa		1	
	Proof pressure	MPa		1.5	
At decoupling	Max working pressure	Mold	MPa	1	
		Machine	MPa	1	
Operating temperature		°C		0 ~ 80 (No freezing)	

Open type WVF-S

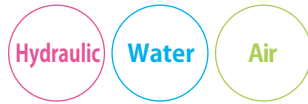

WVF03S

Hole



WVF-S Machine side



Mold

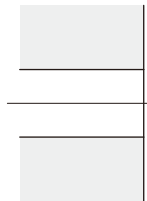

Machine

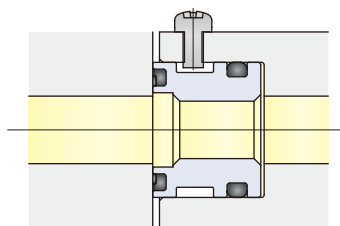
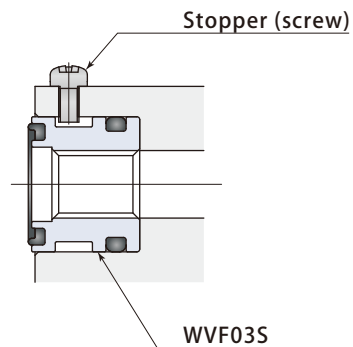

Type of fluid			General mineral-based oil	Water, compressed air
Way of mounting			Embedded	Embedded
Piping size			3/8"	3/8"
Min. orifice area		mm ²	57	57
Model no.			WVF03S	WVF03S
At coupling	Max working pressure		MPa	1
	Proof pressure		MPa	1
At decoupling	Max working pressure	Mold	MPa	—
		Machine	MPa	Open
Operating temperature			°C	
			0 ~ 70 (No freezing)	

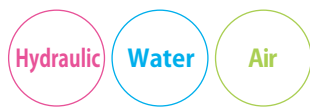

WVG 02 W P – C089

3 **P** : Mold **S** : Machine

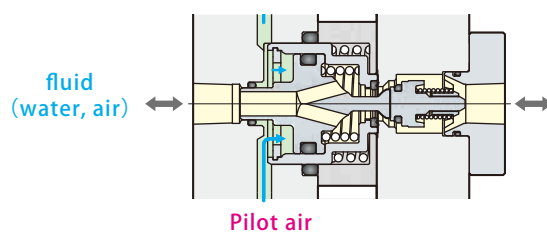
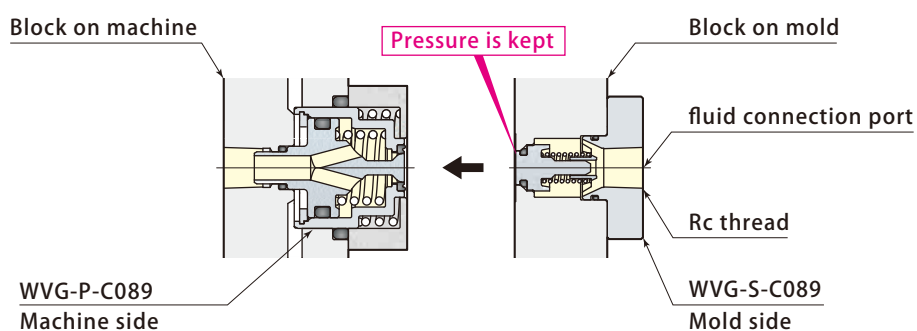

Type of fluid		Heating medium oil		Water, compressed air	
Way of mounting		Flange		Flange	
Piping size		1/4"		1/4"	
Min. orifice area		mm ²	35		35
Model no.		WVG02W-C089		WVG02W-C089	
At coupling	Max working pressure	MPa	1		1
	Proof pressure	MPa	1.5		1.5
At decoupling	Max working pressure	Mold	MPa	Pressure not maintained *No dripping	Pressure not maintained *No dripping
		Machine	MPa	1	1
Operating temperature			°C	0 ~ 150 (No freezing)	0 ~ 150 (not freezing, not boiling)

Magnetic clamp built-in style coupler WVG-S WVG-P



WVG 02 W P - S

- 1 Size
 - 2 H : Hydraulic
 - 3 P : Mold S : Machine
- Affix "S" is added at the end of the model no. when thin type.

- 1 Piping size
- WVG02 : 1/4"
WVG04 : 1/2"
*Thin type for WVG-02 only

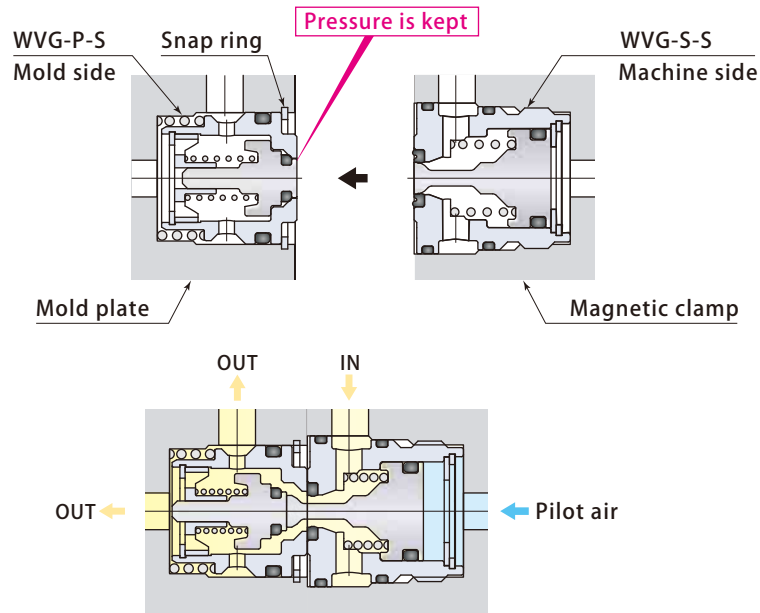
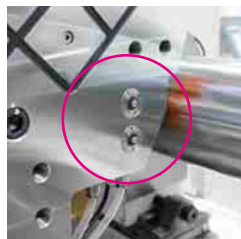

Magnetic plate thickness		Standard		Thin
Type of fluid		Water, compressed air		Water, compressed air
Way of mounting		Screw mount		Ring for mold Screw for machine
Piping size		1/4"	1/2"	1/4"
Min. orifice area	mm ²	35	100	19
Model no.		WVG02W	WVG04W	WVG02W-S
At coupling	Max working pressure	MPa	1	1
	Proof pressure	MPa	1.5	1.5
At decoupling	Max working pressure	Mold	MPa	1
		Machine	MPa	Pressure not maintained *No dripping
Operating temperature		°C	0 ~ 95 (not freezing, not boiling)	0 ~ 95 (not freezing, not boiling)

WVC-P WVC-S (Obsolete)

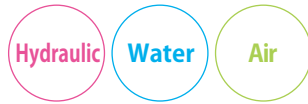

WVC 02 W P

- 1 Size
- 2 H : Hydraulic W : Water, Air
- 3 P : Mold S : Machine

1 Piping size

- WVC02 : 1/4"
- WVC03 : 3/8"
- WVC04 : 1/2"
- WVC06 : 3/4"
- WVC08 : 1"

* WVC is available only for oil.

WVC-P Mold side

WVC-S Machine side

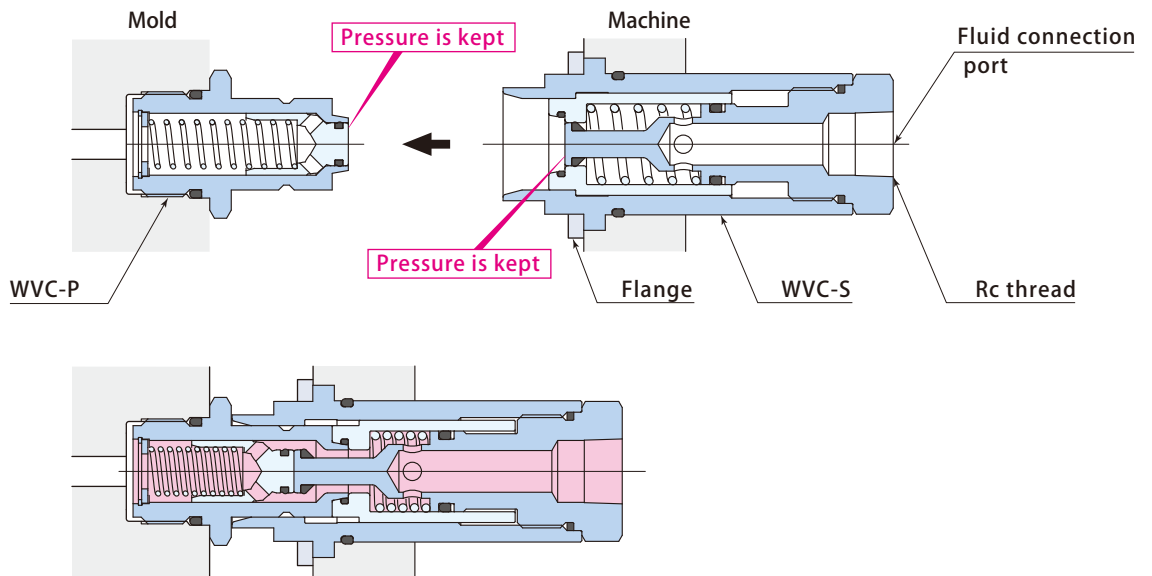

Obsolete

Type of fluid		General mineral-based oil					Water, compressed air					
		Screw for mold		Flange for machine			Screw for mold		Flange for machine			
Way of mounting		Screw for mold		Flange for machine			Screw for mold		Flange for machine			
Piping size		1/4"	3/8"	1/2"	3/4"	1"	1/4"	3/8"	1/2"	3/4"		
Min. orifice area		mm ²		28	28	71	118	218	28	28	71	118
Model no.		WVC02H	WVC03H	WVC04H	WVC06H	WVC08H	WVC02W	WVC03W	WVC04W	WVC06W		
At coupling	Max working pressure	MPa		25			1					
	Proof pressure	MPa		30			1.5					
At decoupling	Max working pressure	Mold	MPa		1			1				
		Machine	MPa		1			1				
Operating temperature		°C		0 ~ 70 (No freezing)			0 ~ 70 (No freezing)					

WVB-P WVB-S (Obsolete)



WVB 08 W P

1 Size •
 3 P : Mold S : Machine •

1 Piping size
 WVB08 : 1"
 WVB10 : 1 1/4"
 WVB12 : 1 1/2"
 WVB16 : 2"

WVB-P Mold side

WVB-S Machine side

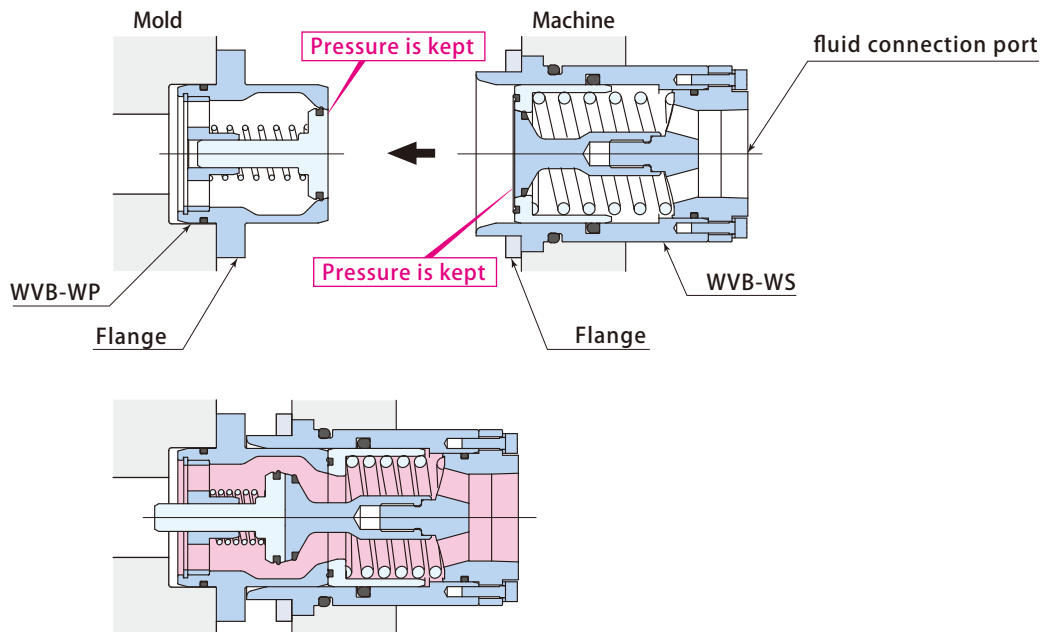

Obsolete

Type of fluid		Water, compressed air				
Way of mounting		Flange *				
Piping size		1"	1 1/4"	1 1/2"	2"	
Min. orifice area		mm ²	382	623	924	1362
Model no.		WVB08W	WVB10W	WVB12W	WVB16W	
At coupling	Max working pressure	MPa	1			
	Proof pressure	MPa	1.5			
At decoupling	Max working pressure	Mold	MPa	1		
		Machine	MPa	1		
Operating temperature		°C	0 ~ 80 (No freezing)			

* When piping size is 1", mounting way of coupler for mold side changes to be screw mount type.

Guide with locking mechanism **WVK-P WVK-S**

A guide pin incorporating locking device enables the coupler block to be compact.

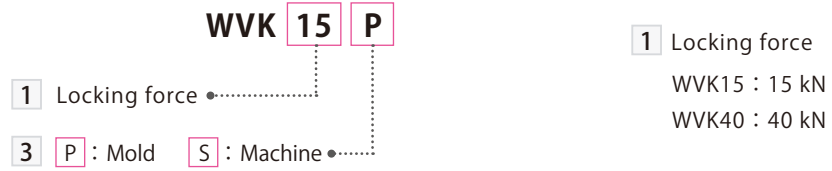

WVK-P Lock guide pin (mold side)

WVK-S Lock guide socket (machine side)

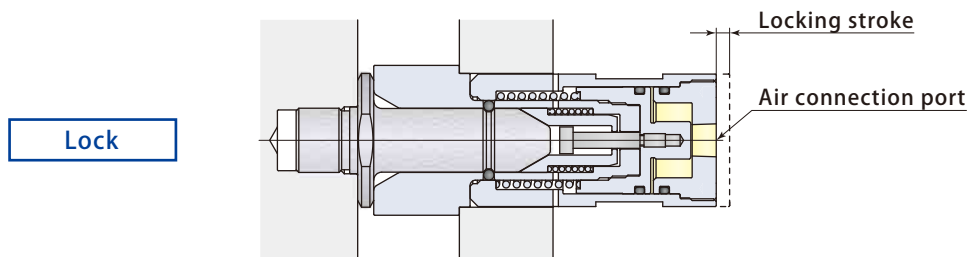
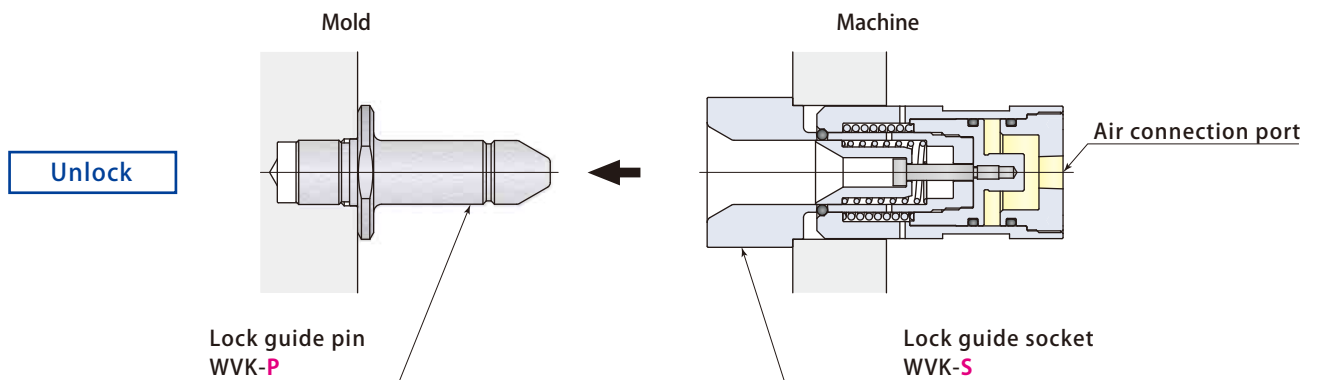

型 式		WVK15P		WVK40P	
		WVK15S		WVK40S	
Locking force	kN	15		40	
Way of locking		By a spring (automatic locking when connection)			
Spring reaction force (when locking)	N	103		103	
Locking stroke	mm	5		8	
Min. operational air pressure	MPa	0.2		0.2	
Max. operational air pressure	MPa	1		1	
Allowable misalignment	mm	±5		±5	
Mass	Mold side (lock guide pin) WVK-□P	kg	0.4	kg	1.2
	Mold side (lock guide socket) WVK-□S	kg	1.9	kg	6.7
Operating temperature	°C	0 ~ 80 (No freezing)			

● Contact Pascal for the usage in case operating temp over 80°C .

Decoupled situation

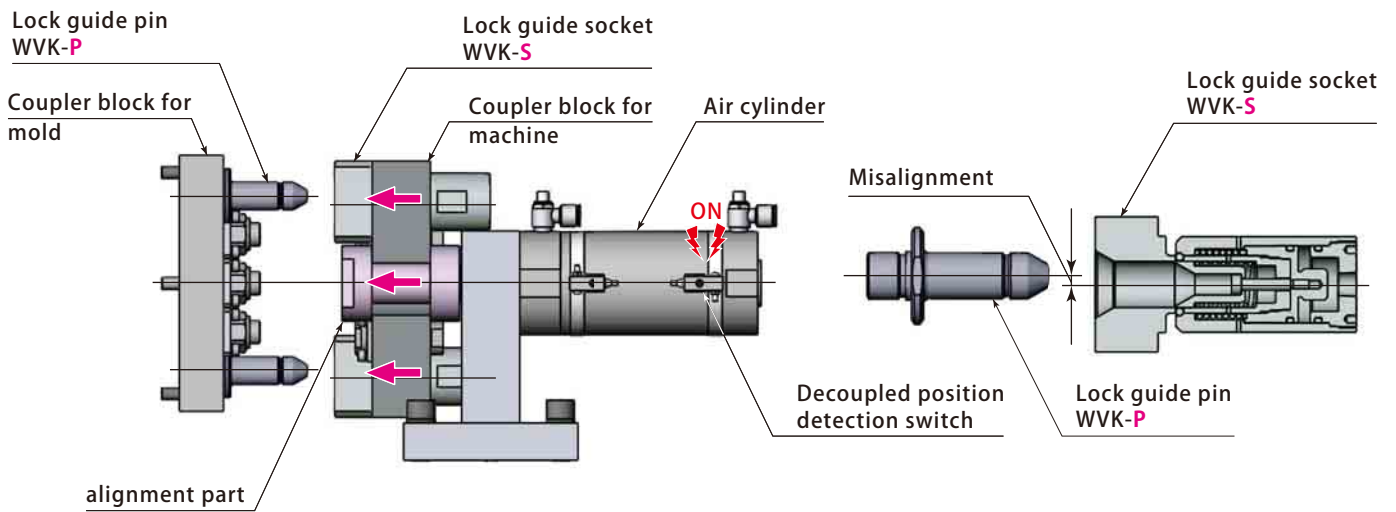

During coupling

Self-aligning ② alignment part

It can correct the displacement
(Max allowance: $\pm 5\text{mm}$)

Self-aligning ① Lock guide

Mold is positioned by the guide pin and tapered part of the socket.

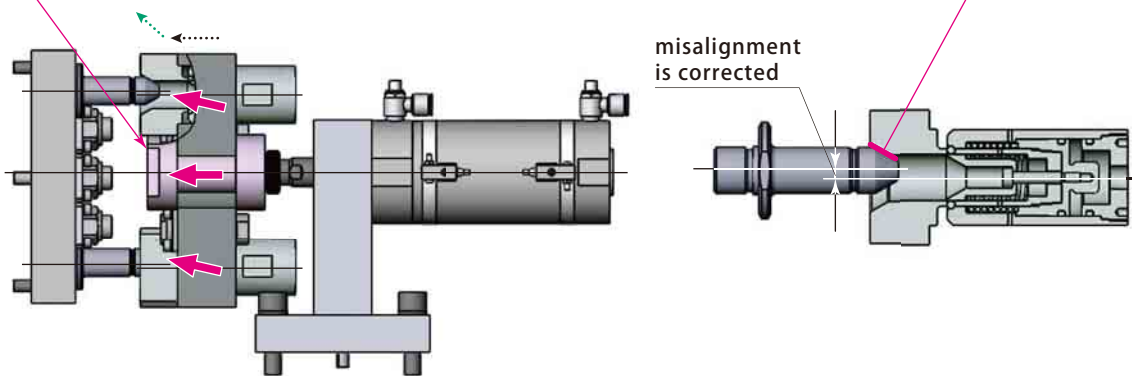

Coupling completed

Locking

The guide pin incorporating with ball lock mechanism can keep the coupled status against the fluid pressure.

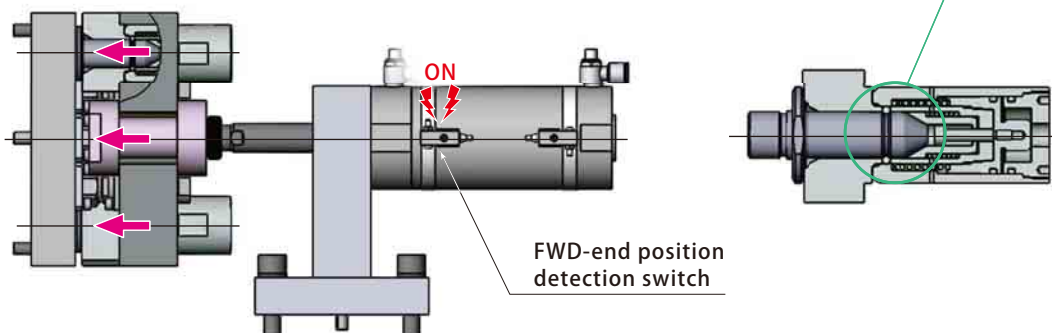

Pascal

corporation

Itami, Hyogo, Japan 664-8502
TEL. +81-72-777-3333 FAX. +81-72-777-3520

Chicago, U.S.A.	TEL. +1-847-427-1234
Stuttgart, Germany	TEL. +49-711-782-850-0
Dalian, China	TEL. +86-411-8732-2988
Shanghai, China	TEL. +86-21-5263-4122
Changwon, Korea	TEL. +82-55-274-0971
Bangkok, Thailand	TEL. +66-2173-5855

