

Compact model

model CLV□-□N

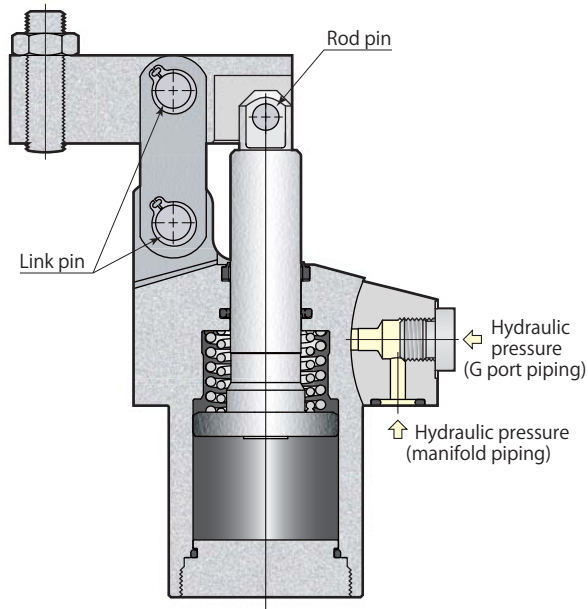

Hydraulic circuit diagram

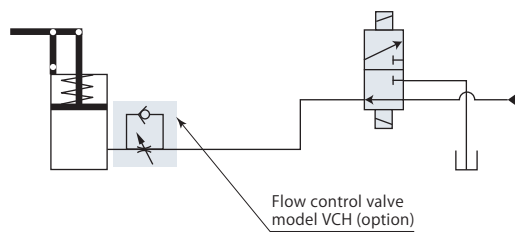

Use flow control valve for meter-in control.

Specifications page → 99

Dimensions page → 102

Mounting details page → 104

Single acting Link clamp

CLV-N Compact model

Specifications

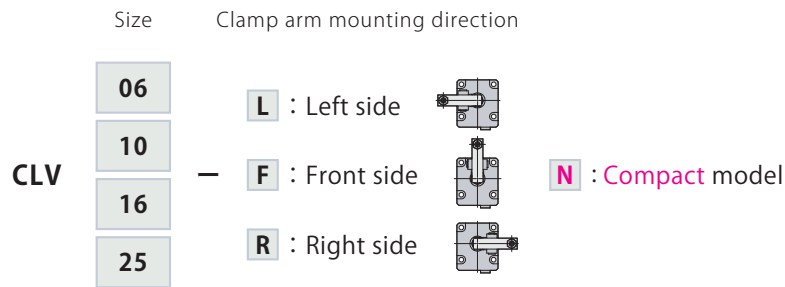

Model			CLV06	CLV10	CLV16	CLV25
Cylinder force (hydraulic pressure 35MPa)*1		kN	6.8	10.5	16.7	24.0
Rod diameter		mm	16	20	25	30
Effective area (clamp)		cm <sup>2</sup>	2.0	3.1	4.9	7.1
Full stroke		mm	26	29.5	36	45
Clamp stroke*2		mm	23	26.5	33	42
Safety stroke		mm	3	3	3	3
Max. oil flow rate		L/min	0.54	1.00	1.93	3.55
Cylinder capacity		cm <sup>3</sup>	5.2	9.3	17.7	31.8
Return spring force	Clamp	kN	0.26	0.45	0.52	0.75
	Unclamp	kN	0.12	0.19	0.30	0.40
Recommended piping inner diameter*3		mm	ø4	ø4	ø6	ø6
Max. allowable mass of clamp arm*4		kg	0.4	0.7	1.2	2.3
Mass		kg	1.4	2.0	3.6	5.9
Recommended tightening torque of mounting screws*5		N·m	12	29	57	100

● Pressure range: 3.5–35 MPa    ● Proof pressure: 52.5 MPa    ● Operating temperature: 0–70 °C

● Fluid used: General mineral based hydraulic oil (ISO-VG32 equivalent)

● Seals are resistant to chlorine-based cutting fluid. (not thermal resistant specification)

\*1: This is value for clamping position.    \*2: Indicates a distance from unclamping position to clamping point.

\*3: Care must be taken when numerous clamps are used or when hydraulic piping is long.

\*4: This is clamp arm mass when shape of clamp arm being described in Dimensions is retained but length only has been extended.

\*5: ISO R898 class 12.9

Manifold piping and G port piping are available.

Manifold piping

When choosing manifold piping, a flow control valve (model VCH) and an air bleeding valve (model VCE) are mountable on the G ports of the clamp.

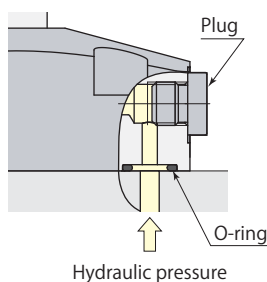

G port piping

Remove plug when choosing G port piping. (O-ring must be used.) The flow control valve and the air bleeding valve should be installed in the middle of oil path.

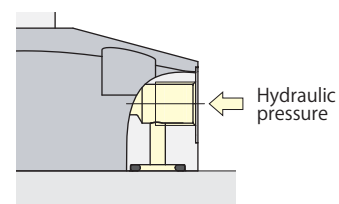

Performance diagram

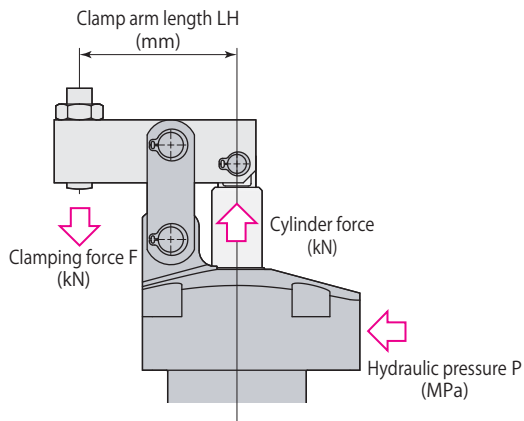

Clamping force varies depending on the clamp arm length (LH) and hydraulic pressure (P).

Clamping force calculation formula

$$F = (\text{Coefficient 1} \times P - \text{Coefficient 2}) / (\text{LH} - \text{Coefficient 3})$$

F: Clamping force P: Hydraulic pressure LH: Clamp arm length

CLV10 with clamp arm length (LH) = 50 mm at hydraulic pressure of 35 MPa, Clamping force F is calculated by  $(6.93 \times 35 - 9.92) / (50 - 24.5) = 9.1$  kN

Do not use the clamp in the nonusable range. It may cause damage to the cylinder and rod.

model CLV06

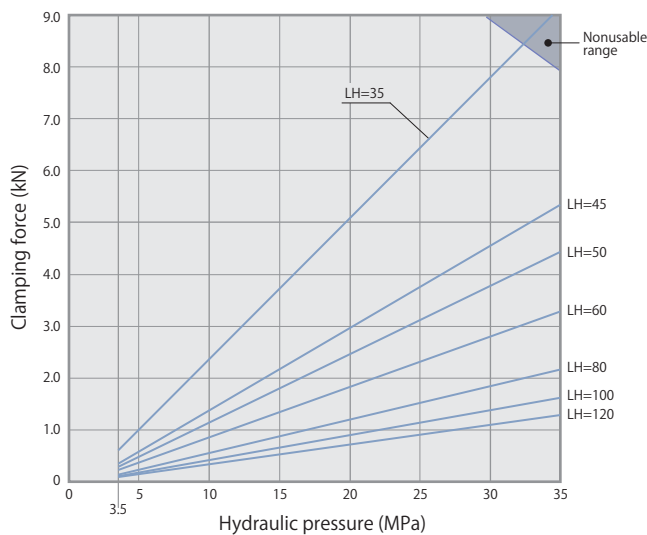

model CLV10

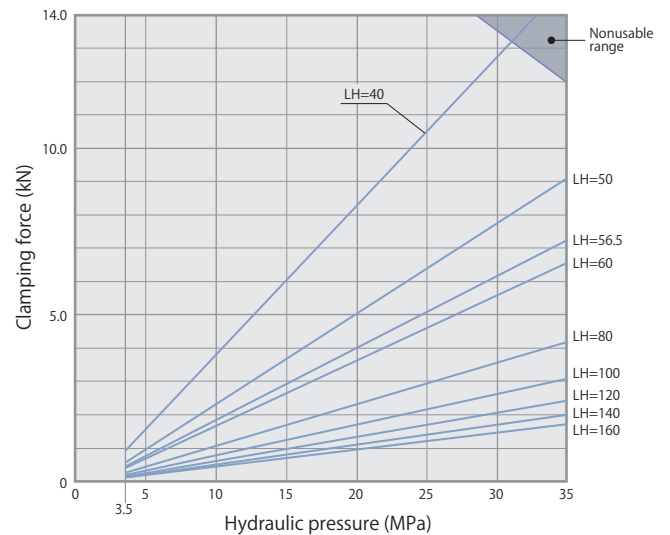

model CLV16

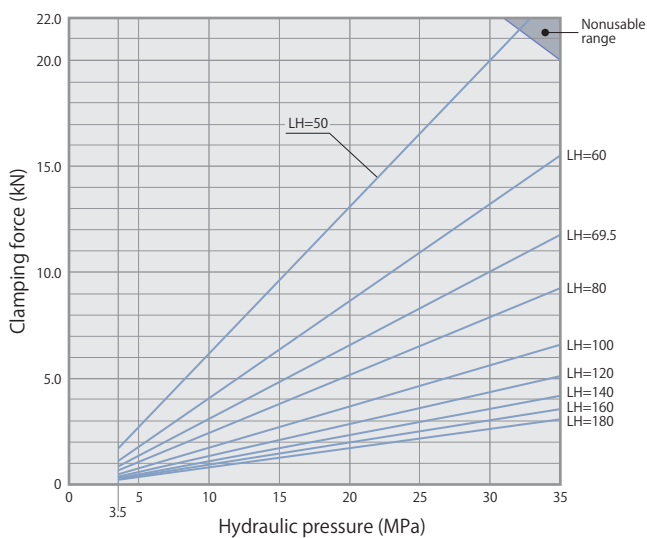

model CLV25

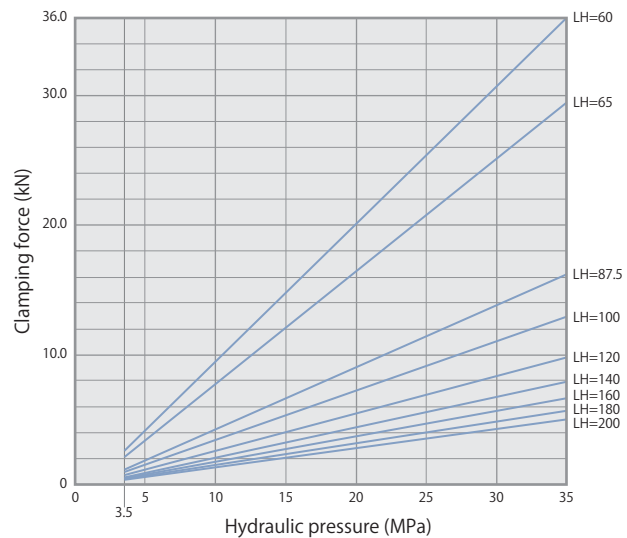

Performance table

**model CLV06** Clamping force  $F=(3.80 \times P-4.91)/(LH-21.0)$

Hydraulic pressure MPa	Cylinder force kN	Clamping force kN							Min. arm length Min. LH mm
		Clamp arm length LH mm							
		35	45	50	60	80	100	120	
35	6.8		5.3	4.4	3.3	2.2	1.6	1.3	37.5
30	5.8	7.8	4.5	3.8	2.8	1.8	1.4	1.1	35
25	4.8	6.4	3.8	3.1	2.3	1.5	1.1	0.9	↑
20	3.8	5.1	3.0	2.5	1.8	1.2	0.9	0.7	↑
15	2.8	3.7	2.2	1.8	1.3	0.9	0.7	0.5	↑
10	1.8	2.4	1.4	1.1	0.8	0.6	0.4	0.3	↑
5	0.7	1.0	0.6	0.5	0.4	0.2	0.2	0.1	↑
3.5	0.4	0.6	0.3	0.3	0.2	0.1	0.1	0.1	35
Max. pressure MPa		32.4	35	35	35	35	35	35	

■ indicates nonusable range

**model CLV10** Clamping force  $F=(6.93 \times P-9.92)/(LH-24.5)$

Hydraulic pressure MPa	Cylinder force kN	Clamping force kN										Min. arm length Min. LH mm
		Clamp arm length LH mm										
		40	50	56.5	60	80	100	120	140	160		
35	10.5		9.1	7.3	6.6	4.2	3.1	2.4	2.0	1.7		44
30	9.0	12.8	7.8	6.2	5.6	3.6	2.6	2.1	1.7	1.5		40
25	7.4	10.5	6.4	5.1	4.6	2.9	2.2	1.7	1.4	1.2		↑
20	5.8	8.3	5.0	4.0	3.6	2.3	1.7	1.3	1.1	0.9		↑
15	4.3	6.1	3.7	2.9	2.6	1.7	1.2	1.0	0.8	0.7		↑
10	2.7	3.8	2.3	1.9	1.7	1.1	0.8	0.6	0.5	0.4		↑
5	1.1	1.6	1.0	0.8	0.7	0.4	0.3	0.3	0.2	0.2		↑
3.5	0.6	0.9	0.6	0.4	0.4	0.3	0.2	0.2	0.1	0.1		40
Max. pressure MPa		31.0	35	35	35	35	35	35	35	35		

■ indicates nonusable range

**model CLV16** Clamping force  $F=(13.47 \times P-14.27)/(LH-30.5)$

Hydraulic pressure MPa	Cylinder force kN	Clamping force kN										Min. arm length Min. LH mm
		Clamp arm length LH mm										
		50	60	69.5	80	100	120	140	160	180		
35	16.7		15.5	11.7	9.2	6.6	5.1	4.2	3.5	3.1		53.5
30	14.2	20.0	13.2	10.0	7.9	5.6	4.4	3.6	3.0	2.6		50
25	11.8	16.5	10.9	8.3	6.5	4.6	3.6	2.9	2.5	2.2		↑
20	9.3	13.1	8.6	6.5	5.2	3.7	2.9	2.3	2.0	1.7		↑
15	6.8	9.6	6.4	4.8	3.8	2.7	2.1	1.7	1.5	1.3		↑
10	4.4	6.2	4.1	3.1	2.4	1.7	1.3	1.1	0.9	0.8		↑
5	1.9	2.7	1.8	1.4	1.1	0.8	0.6	0.5	0.4	0.4		↑
3.5	1.2	1.7	1.1	0.8	0.7	0.5	0.4	0.3	0.3	0.2		50
Max. pressure MPa		32.1	35	35	35	35	35	35	35	35		

■ indicates nonusable range

**model CLV25** Clamping force  $F=(23.86 \times P-25.31)/(LH-37.5)$

Hydraulic pressure MPa	Cylinder force kN	Clamping force kN										Min. arm length Min. LH mm
		Clamp arm length LH mm										
		60	65	87.5	100	120	140	160	180	200		
35	24.0	36.0	29.4	16.2	13.0	9.8	7.9	6.6	5.7	5.0		60
30	20.5	30.7	25.1	13.8	11.0	8.4	6.7	5.6	4.8	4.2		↑
25	16.9	25.4	20.8	11.4	9.1	6.9	5.6	4.7	4.0	3.5		↑
20	13.4	20.1	16.4	9.0	7.2	5.5	4.4	3.7	3.2	2.8		↑
15	9.9	14.8	12.1	6.7	5.3	4.0	3.2	2.7	2.3	2.0		↑
10	6.3	9.5	7.8	4.3	3.4	2.6	2.1	1.7	1.5	1.3		↑
5	2.8	4.2	3.4	1.9	1.5	1.1	0.9	0.8	0.7	0.6		↑
3.5	1.7	2.6	2.1	1.2	0.9	0.7	0.6	0.5	0.4	0.4		60
Max. pressure MPa		35	35	35	35	35	35	35	35	35		

Single acting Link clamp

CLV-N Compact model

Dimensions

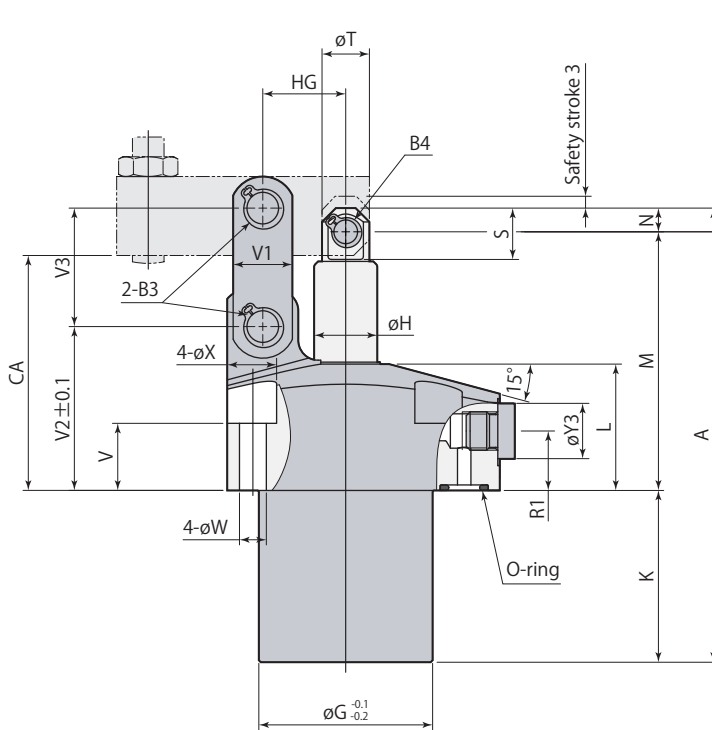
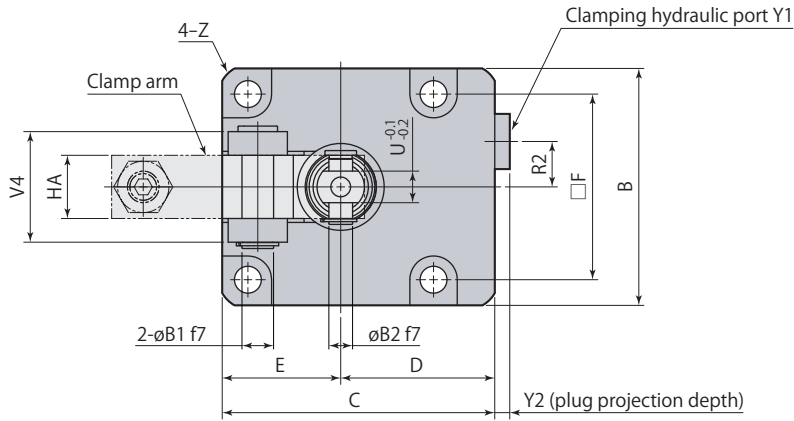

Clamp

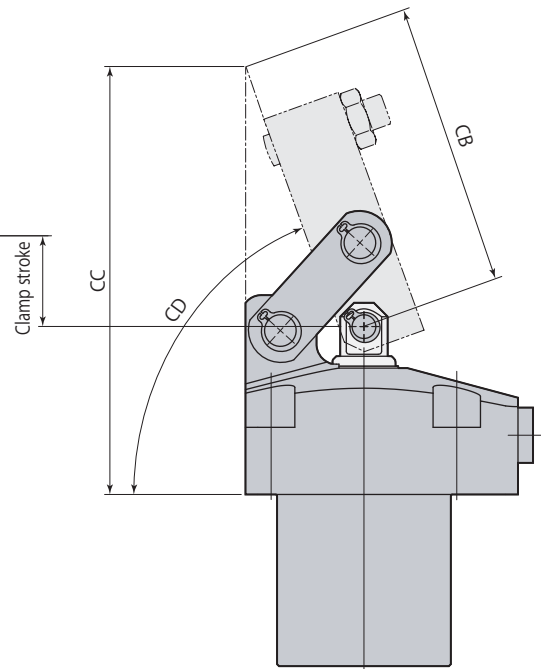

Unclamp

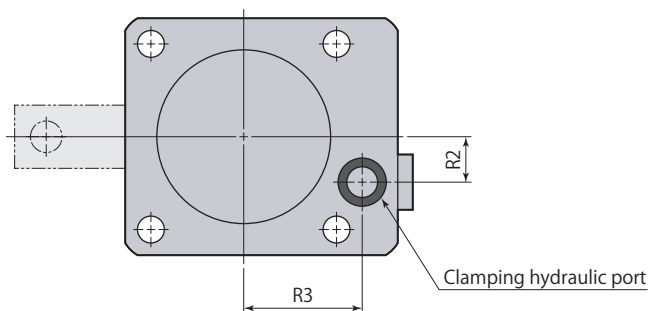

● This diagram represents external contour of CLV □-FN. CLV□-LN and CLV□-RN differ only in terms of mounting direction of clamp arm and otherwise all dimensions are identical to those of CLV□-FN.

L: Left side F: Front side R: Right side

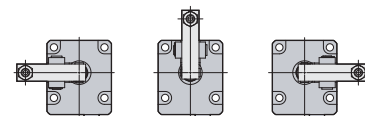

● Clamp arm and mounting screws are not included.

mm

Model	CLV06-□N	CLV10-□N	CLV16-□N	CLV25-□N
A	115	134	160	190.5
B	60	70	86	108
C	69	77	96	110
D	39	42	53	56
E	30	35	43	54
F	47	54	65	85
øG	44	48	58	66
øH	16	20	25	30
K	43.5	53	60	69
L	32	33.5	41	47
M	65.5	73	89	108.5
N	6	8	11	13
R1	15	15	17	21
R2	11.5	13	15	20
R3	30	33	40	43
S	13	17	21.8	27.5
øT	12	15	20	26
U (width across flats)	8	10	11	16
V	17	17	20	21
V1	15	19	25	32
V2	41.5	45	54.5	65
V3	30	35.5	44	53
V4	28	37	46	56
øW	6.8	9	11	14
øX	12	15	18.5	20.5
Y1	G1/8	G1/8	G1/4	G1/4
Y2	3.8	3.8	4.8	4.8
Y3	14	14	19	19
Z	C2.5	C3	C3.5	C5.5
øB1	8 <sup>-0.013 -0.028</sup>	10 <sup>-0.013 -0.028</sup>	14 <sup>-0.016 -0.034</sup>	16 <sup>-0.016 -0.034</sup>
øB2	6 <sup>-0.010 -0.022</sup>	8 <sup>-0.013 -0.028</sup>	12 <sup>-0.016 -0.034</sup>	14 <sup>-0.016 -0.034</sup>
B3 (snap ring)*1	STW-8	STW-10	STW-14	STW-16
B4 (snap ring)*1	STW-6	STW-8	STW-12	STW-14
CA	59.5	65	80	96
CB	71.7	78.7	98.2	133.5
CC	107.9	117.4	144.7	189.2
CD	About 70°	About 70°	About 69°	About 72°
HA	16	19	22	32
HG	21	24.5	30.5	37.5
O-ring (fluorocarbon hardness Hs90)	P9	P9	P9	P9
Flow control valve (meter-in)*2	VCH01	VCH01	VCH02	VCH02
Air bleeding valve*2	VCE01	VCE01	VCE02	VCE02

\*1: Snap ring is made by Ochiai Corporation.

\*2: Select the right model of VCH and VCE according to the size of the clamp.

Refer to each page for the details of options. ● Flow control valve **page →108** ● Air bleeding valve **page →110**

Mounting details

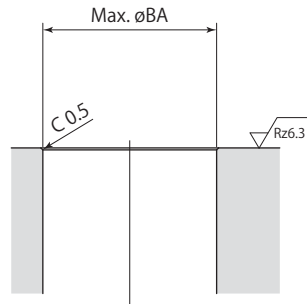
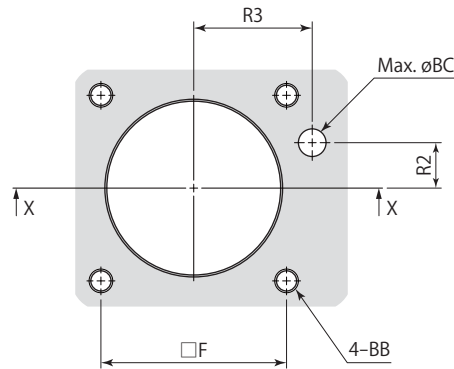

X-X

Rz: ISO4287(1997)

mm

Model	CLV06-□N	CLV10-□N	CLV16-□N	CLV25-□N
F	47	54	65	85
R2	11.5	13	15	20
R3	30	33	40	43
øBA	47	52	62	72
BB	M6	M8	M10	M12
øBC	7	7	7	7

### Clamp arm mounting details

Clamp arm is not included. Manufacture a clamp arm with the dimensions shown in the table below.

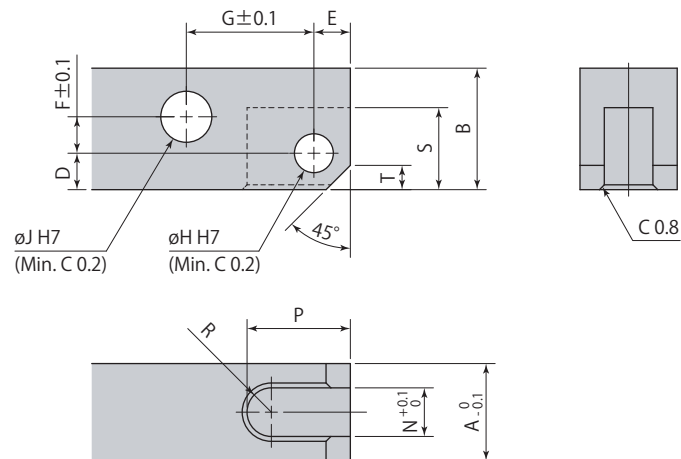

Recommended material: S45C (HB167–229)

Link clamp	CLV06-□N	CLV10-□N	CLV16-□N	CLV25-□N
A	16	19	22	32
B	20	25	31	38
D	6	8	9	12.5
E	6	7	10	13
F	6	7.5	9.5	9.5
G	21	24.5	30.5	37.5
$\varnothing H$	$6^{+0.012}_0$	$8^{+0.015}_0$	$12^{+0.018}_0$	$14^{+0.018}_0$
$\varnothing J$	$8^{+0.015}_0$	$10^{+0.015}_0$	$14^{+0.018}_0$	$16^{+0.018}_0$
N	8	10	11	16
P	17	20	26.5	36
R	R4	R5	R5.5	R8
S	13.5	17.5	22	28
T	4	5	7	8

● When mounting the clamp arm, use included pins and snap rings.



### Allowable eccentricity of clamp arm

An eccentric shape clamp arm, as shown in diagram on right can be used with link clamp model CLV, if it is not possible to set clamping point at tip section of clamp arm in alignment with center line of piston rod and clamp arm.

Amount of eccentricity, however, must be within allowable eccentricity shown below.

Using a clamp arm that exceeds allowable eccentricity results in significant eccentric load on link mechanism and piston rod, leading to malfunction.

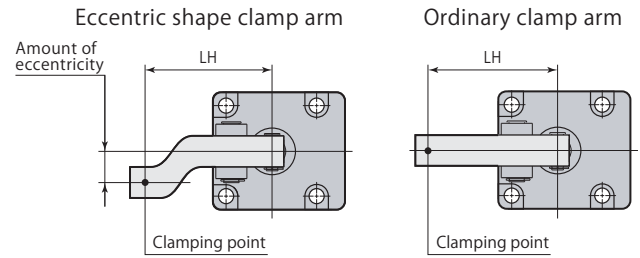

Single acting Link clamp

CLV-N Compact model

model CLV06		■ indicates nonusable range								
Hydraulic pressure MPa	Allowable eccentricity mm									
	Clamp arm length LH mm									
	35	45	50	60	70	80	90	100	120	
35	■	8	8	8	8	8	8	8	8	
30	8	12	13	15	17	19	21	23	26	
25	12	25	28	36	43	50	57	65	79	
20	19	44	52	67	80	80	80	80	80	
15	33	67	80	80	↑	↑	↑	↑	↑	
10	62	80	↑	↑	↑	↑	↑	↑	↑	
5	80	80	80	80	80	80	80	80	80	

model CLV10		■ indicates nonusable range								
Hydraulic pressure MPa	Allowable eccentricity mm									
	Clamp arm length LH mm									
	40	50	56.5	60	80	100	120	140	160	
35	■	12	18	19	24	30	35	41	46	
30	9	19	28	34	53	69	85	95	95	
25	10	28	40	47	83	95	95	↑	↑	
20	18	42	58	67	95	↑	↑	↑	↑	
15	33	67	89	95	↑	↑	↑	↑	↑	
10	66	95	95	↑	↑	↑	↑	↑	↑	
5	95	95	95	95	95	95	95	95	95	

model CLV16		■ indicates nonusable range								
Hydraulic pressure MPa	Allowable eccentricity mm									
	Clamp arm length LH mm									
	50	60	69.5	80	100	120	140	160	180	
35	■	11	16	27	47	67	87	108	110	
30	11	17	30	45	72	100	110	110	↑	
25	14	33	51	71	110	110	↑	↑	↑	
20	29	56	82	110	↑	↑	↑	↑	↑	
15	56	97	110	↑	↑	↑	↑	↑	↑	
10	110	110	↑	↑	↑	↑	↑	↑	↑	
5	110	110	110	110	110	110	110	110	110	

model CLV25		Allowable eccentricity mm								
Hydraulic pressure MPa	Clamp arm length LH mm									
	60	65	87.5	100	120	140	160	180	200	
	35	16	16	52	72	104	136	160	160	160
30	16	24	68	92	130	160	↑	↑	↑	
25	25	37	91	121	160	↑	↑	↑	↑	
20	41	56	126	160	↑	↑	↑	↑	↑	
15	68	90	160	↑	↑	↑	↑	↑	↑	
10	126	160	↑	↑	↑	↑	↑	↑	↑	
5	160	160	160	160	160	160	160	160	160	

Caution in use

- With link clamps, force acting on link mechanism becomes larger as clamp arm becomes shorter. Exceeding maximum allowable load for link mechanism will lead to malfunction. Depending on clamp arm length, it would be necessary to lower clamping force (hydraulic pressure). Use a clamp at appropriate clamping force that is suitable for clamp arm length, referring to performance diagram and table.
- Determine height and mount clamp, ensuring that clamp arm becomes parallel to clamping surface and mounting surface when workpiece is clamped (allowable angle  $\pm 3^\circ$ ).
- Using a method such as that shown in the diagram on the right will apply a transverse force on the piston rod and cause the piston rod to break. Please avoid the usage that may apply a non-axial force to the piston rod.

