

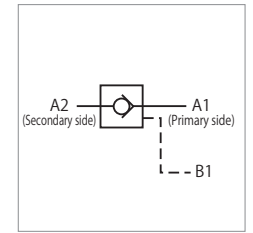

Pilot check valve model VCP

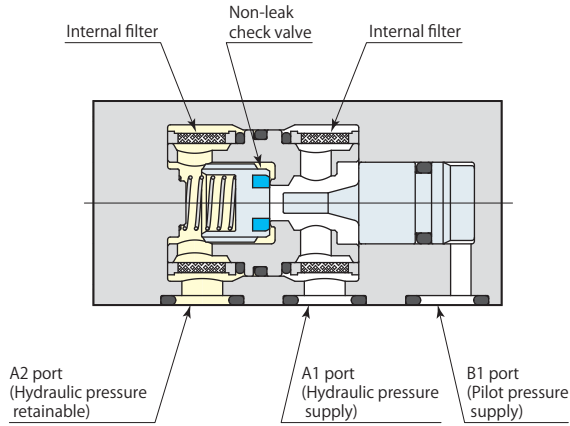

This is a non-leak pilot check valve, with which clamping circuit pressure can be retained over a long period of time after disengagement of hydraulic pressure source.

Specifications

Model		VCP-LG
Mounting, piping methods		Manifold mounting
Pressure range	MPa	1-7
Proof pressure	MPa	10.5
Cracking pressure	MPa	0.019
Min. pilot pressure (open valve)	MPa	0.01 + 0.24 × A2 hydraulic port (secondary side) pressure
Orifice area	mm ²	14.2
Operating temperature	°C	0-70
Fluid used		General mineral based hydraulic oil (ISO-VG32 equivalent)
Mass	kg	0.5

● Fluorocarbon has been adopted for seal sections where cutting fluid is applied, as a measure for the use of chlorine-based cutting fluid (this is not thermal resistant specification).

Dimensions

VCP-LG Manifold mounting *With internal filter (A1 & A2 hydraulic ports)

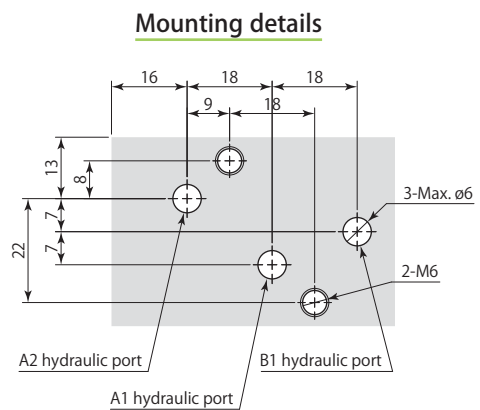
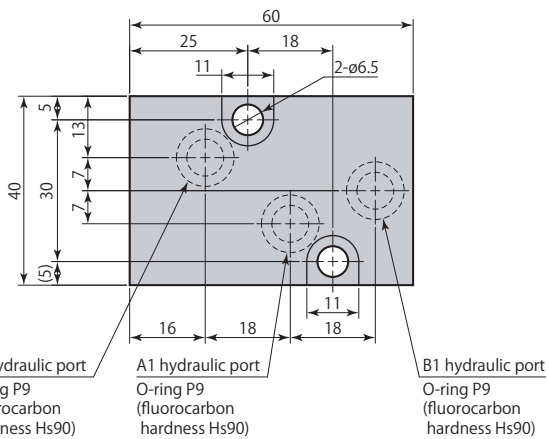

For manifold piping, the mounting surface finish must be no rougher than Rz6.3 (ISO4287:1997).



- Mounting screws are not included.
- This valve cannot be used in the circuit which pressure is applied to both of A1 and B1 port.

Pilot check valve
VCP