

# Die stopper

Alternative to die fall protection hook

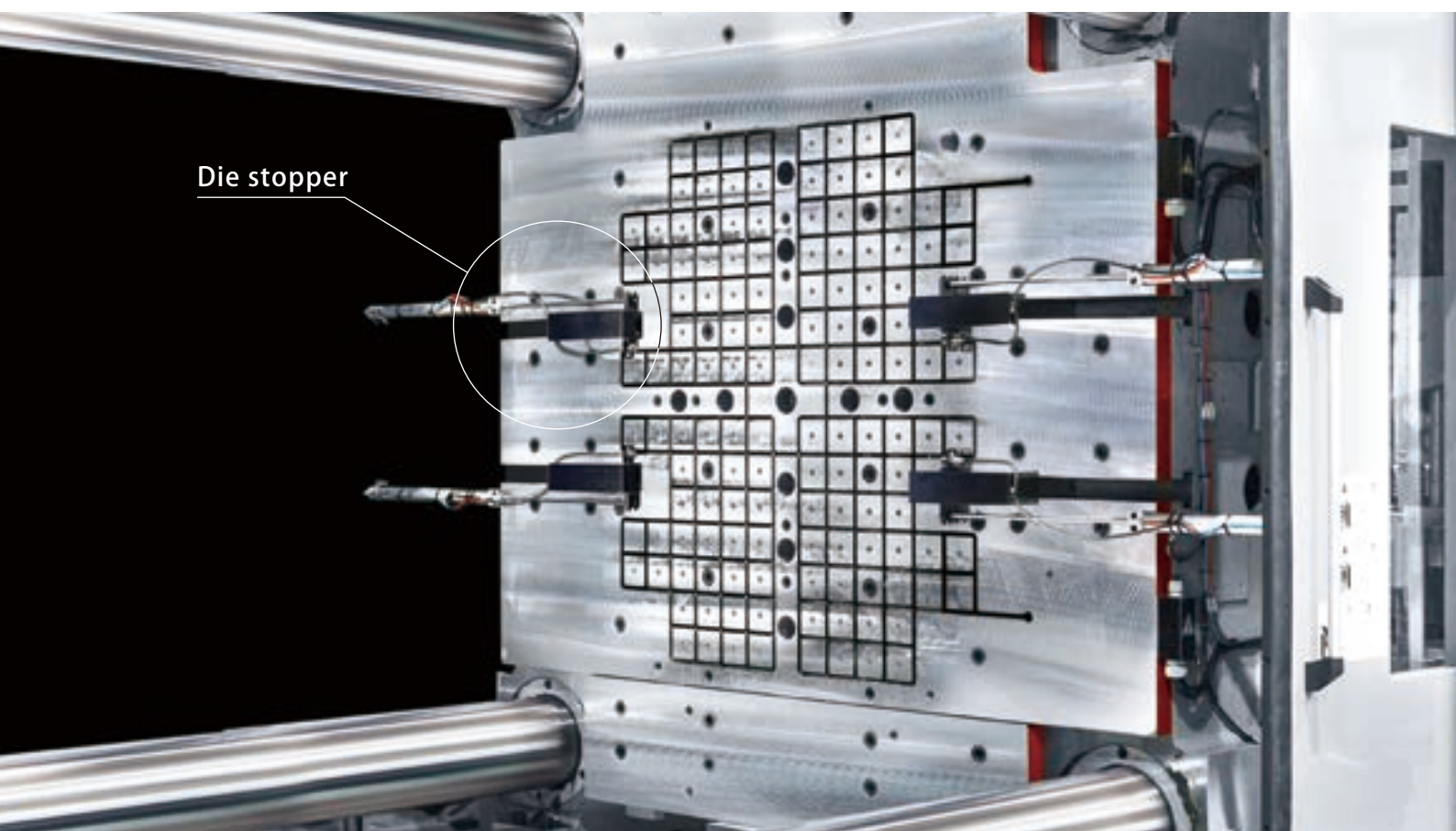

PAT. P.

## Alternative to die fall protection hook — Die stopper

It surely prevents die fall due to the misplacement of ejector and nozzle touch and quick die clamping operation can be realized.

Movable platen

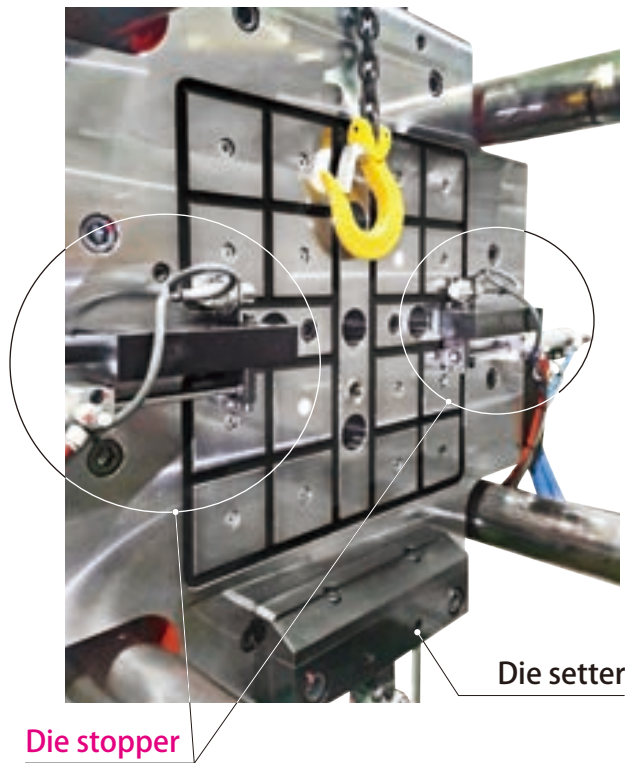

fixed platen

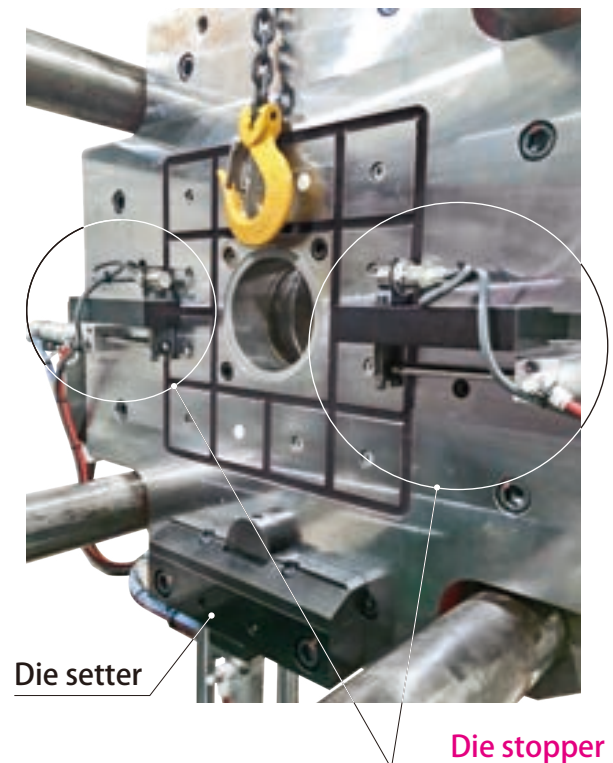

Die fall protection hook

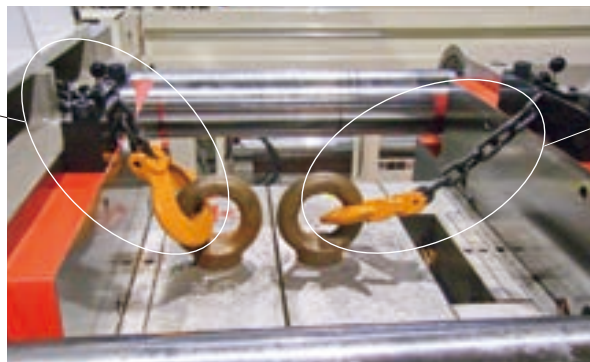

Die fall protection hook

# Die stopper

Applicable for IMM  
up to  
**3,500 kN**

## Standby (when unclamping)

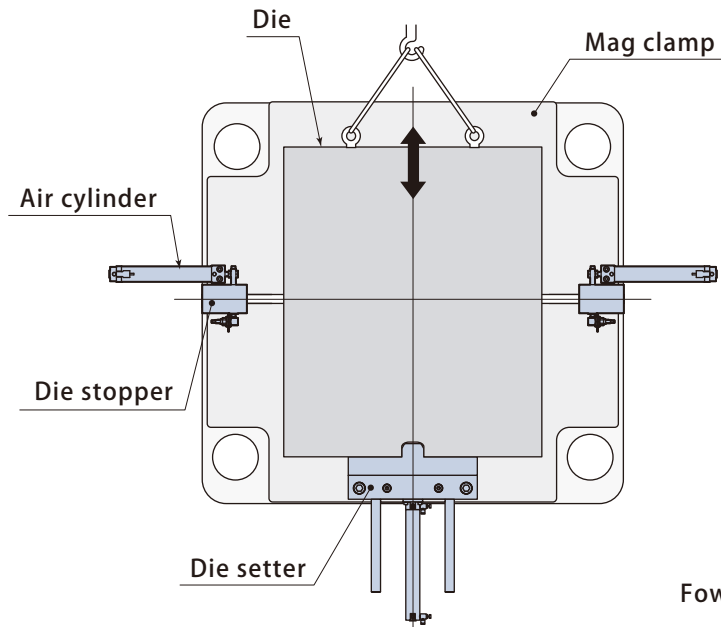

## Fowarding by air cylinder

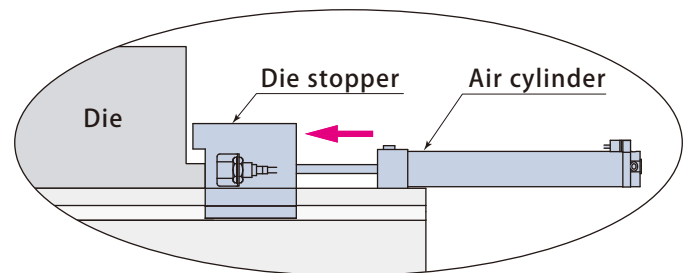

## Setting die (when clamping)

The die stopper forwards interlocking with clamp ON.

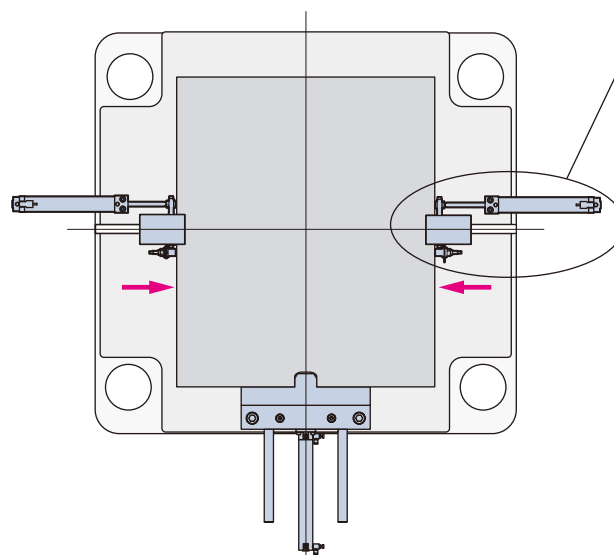

- Contact Pascal for more information if the IMM capacity is over 3,500kN.
- The die stopper can not be used in combination with die fall protection hook.
- The long stroke is not applicable for the die stopper and use a die fall protection hook as before.

# Pascal

corporation

Itami, Hyogo, Japan 664-8502  
TEL. +81-72-777-3333 FAX. +81-72-777-3520

---

Chicago, U.S.A.	TEL. +1-847-427-1234
Stuttgart, Germany	TEL. +49-711-782-850-0
Dalian, China	TEL. +86-411-8732-2988
Shanghai, China	TEL. +86-21-5263-4122
Changwon, Korea	TEL. +82-55-274-0971
Bangkok, Thailand	TEL. +66-2173-5855

---

