

Pascal

Roller gear driven type **Rotator** model **SMR-V** (with V block)



Pascal corporation

For your safe and quick wire roll rotation.

Industrial Safety and Health law requires employers a safe workplace for employees.
Consider Pascal rotator for handling wire roll or wire roll rotation safely and quickly.

Rotary beacon light, panel stand and back cover as standard



Mold rotator Roller gear driven type
model **SMR-V**



Operation panel

Stand
(Standard equipment)

Hanging hook



Motor-driven, roller gear (oilless) and Maintenance free

Pascal mold rotator employs the unique roller gear drive (PAT.) which ensures semipermanental durability. In addition to it, the roller gear mechanism with excellent safety enables sufficient rigidity at sudden stop during operation.

- No maintenance necessary like the system with chain-drive (Elongation adjustment).
- No hydraulic unit or cylinder is provided.

New mechanism for the rotator PAT. P.

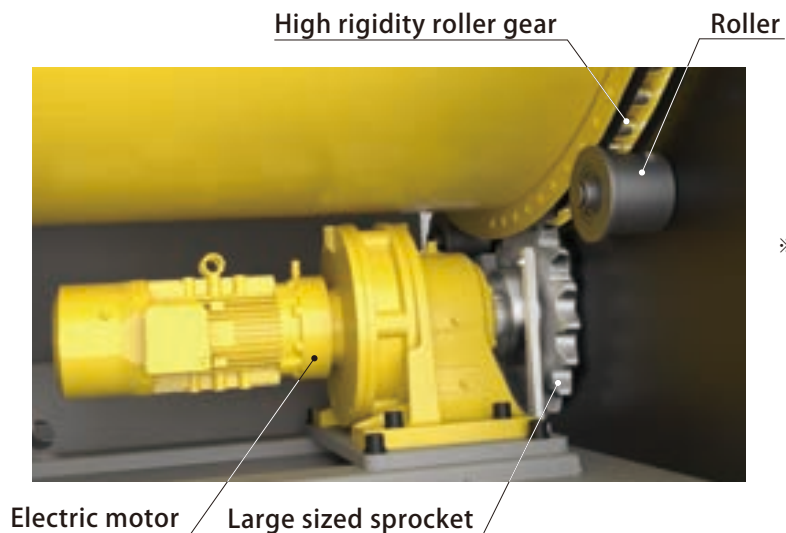
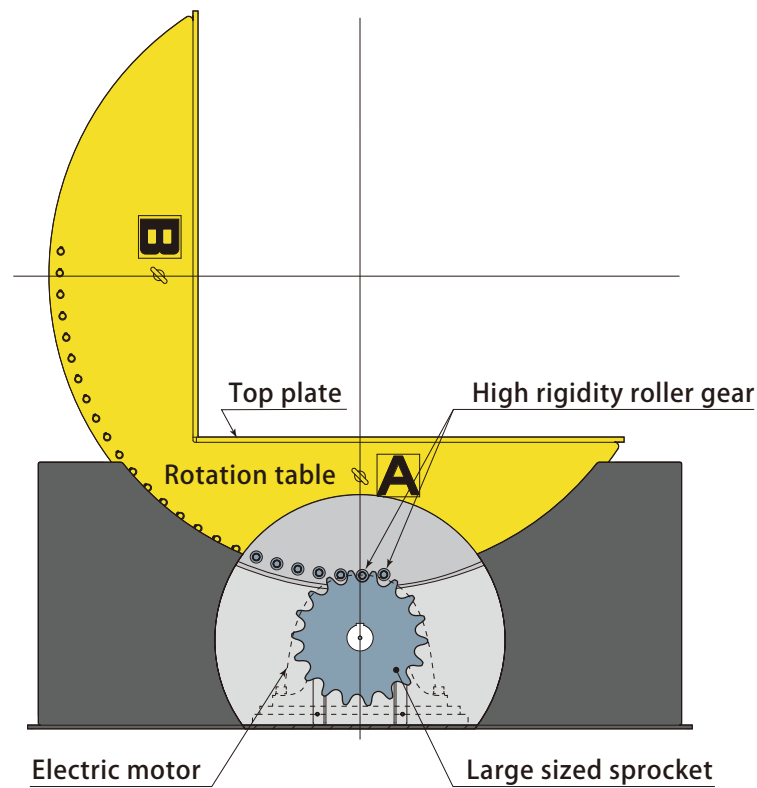

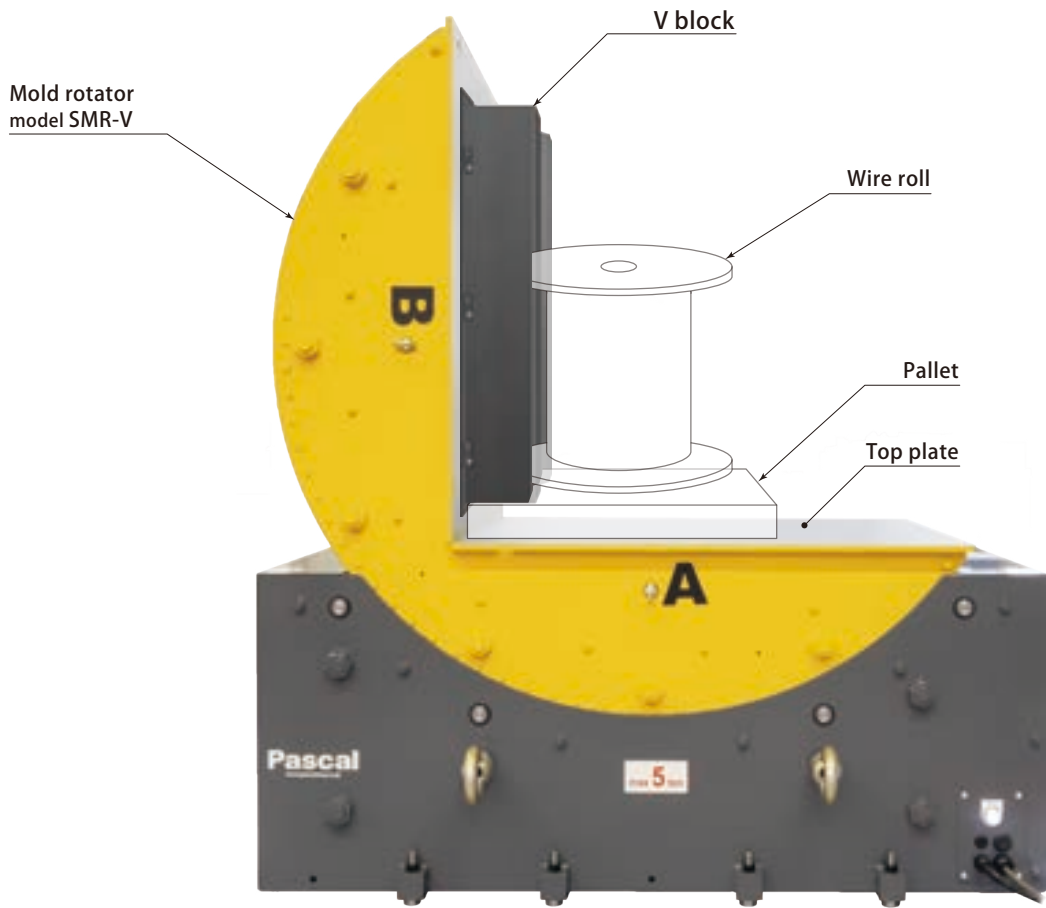

① Place a wire roll

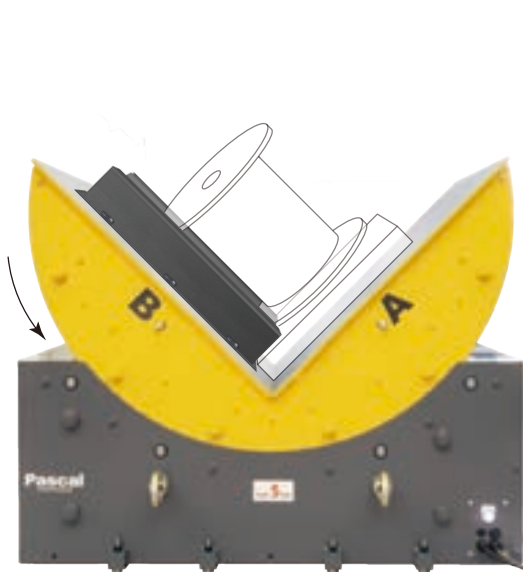

② Rotating

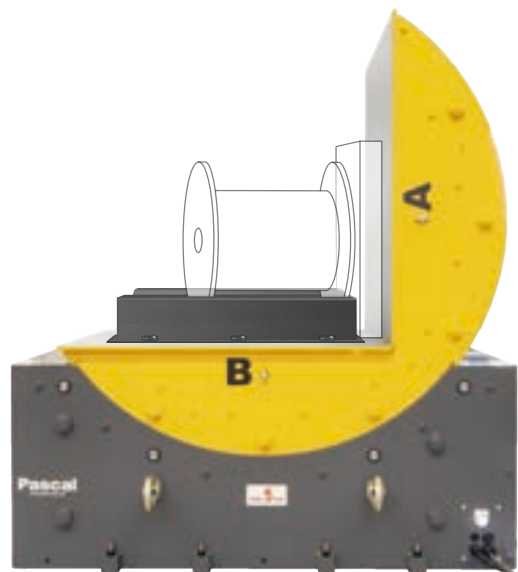

③ Rotation completed

Rotatable weight	90° Rotation time (at 60 Hz)	Model
3 ton	25 sec.	SMR 03 - CV
5 ton	25 sec.	SMR 05 - CV
10 ton	25 sec.	SMR 10 - CV
15 ton	45 sec.	SMR 15 - CV

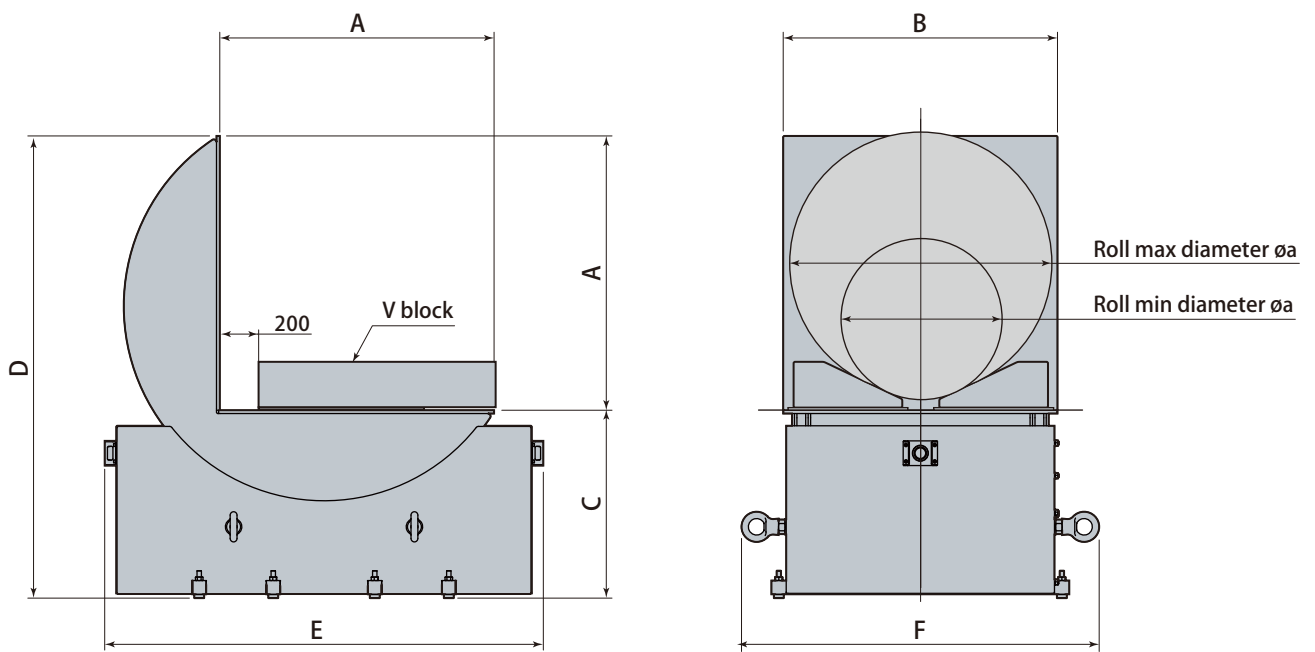

● Power-supply voltage : AC200V 50/60Hz Contact Pascal for other voltage.

Model		SMR03-V	SMR05-V	SMR10-V	SMR15-V
Max. rotation weight	ton	3	5	10	15
90° Rotation time (at 60 Hz)	sec.	25	25	25	45
Drive motor (AC200V, 3-phase)	kW	0.4	0.75	1.5	1.5
Power capacity	kVA	3	3	5	5
Weight	ton	1.4	1.5	2.3	3.8
A	mm	1000	1000	1260	1600
B	mm	1000	1000	1150	1400
C	mm	685	685	864	1045
D	mm	1685	1685	2124	2645
E	mm	1599	1599	2089	2589
F	mm	1304	1304	1459	1762
Max. øa	mm	1000	1000	1100	1300
Min. øa	mm	600	600	800	1000

Do not rotate the heavy materials (Mold) which go beyond the range of gravity.

The 90° rotator increases its rotational force under its own weight when the rotation angle exceeds 45°. The motor tries to rotate at a constant speed, but if the position of the center of gravity becomes higher, the rotation speed will exceed the motor's controllability and it will not be able to stop, so the rotating plate may get over the mechanical stopper and there is a risk of fall over the rotating object. As it is extremely dangerous, the center of gravity of the rotating object within the range specified in the drawings and specifications.

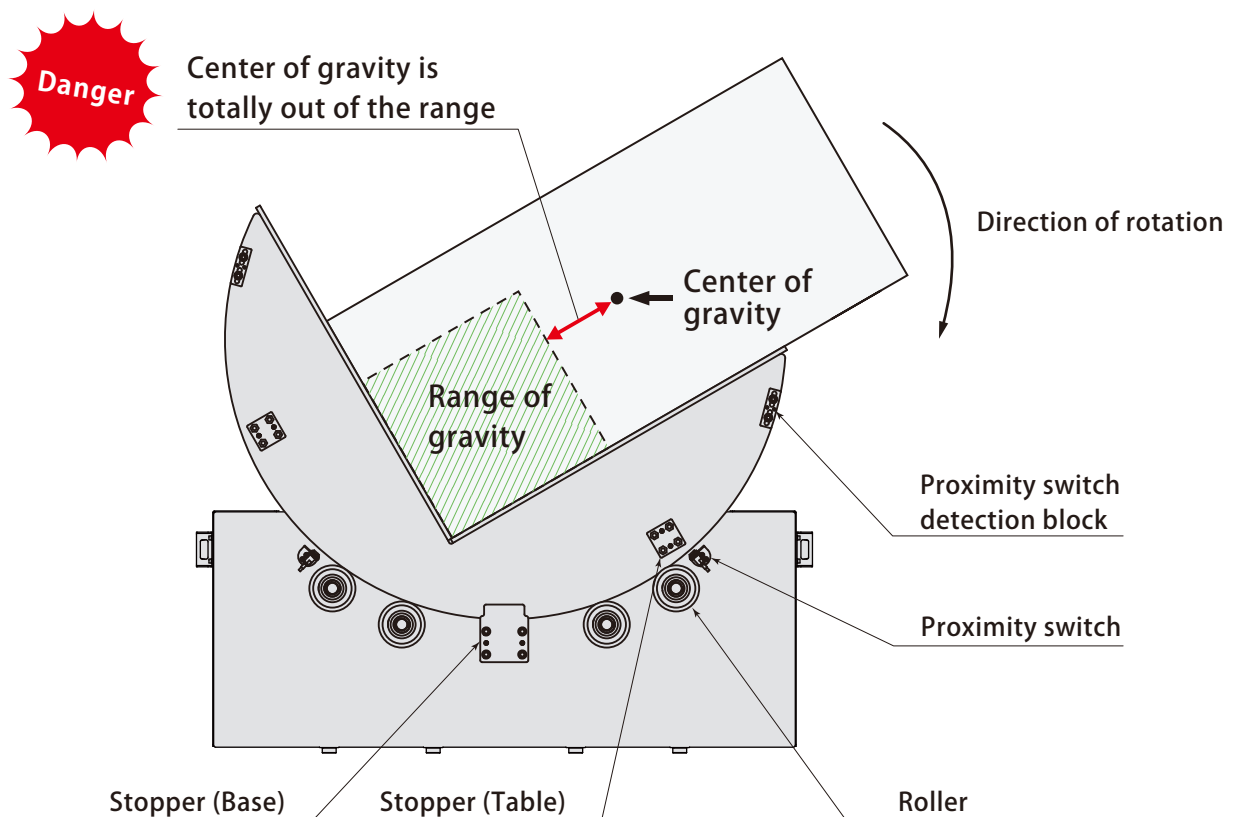

High risk of accident !

Two-hand operable pendant switch is adopted for safer operation.

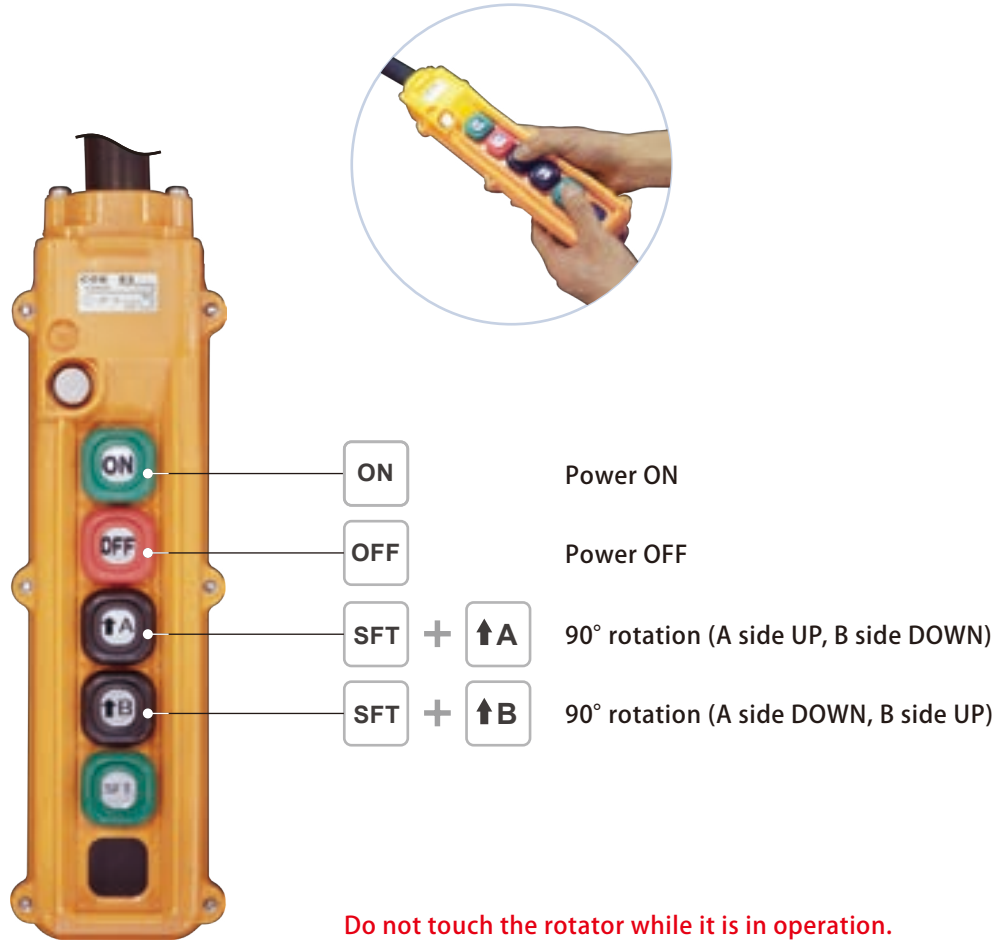

Panel stand (Standard equipment)

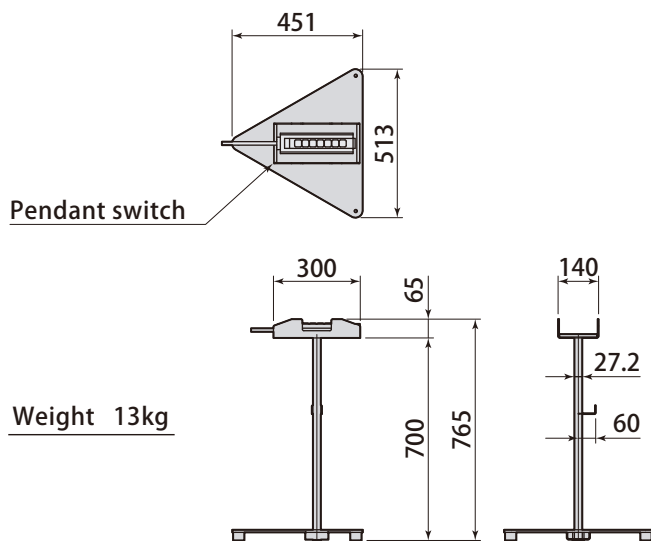

Eliminate the risk of an accident of mold rotating work by the overhead crane and improve the workability with Pascal rotator.

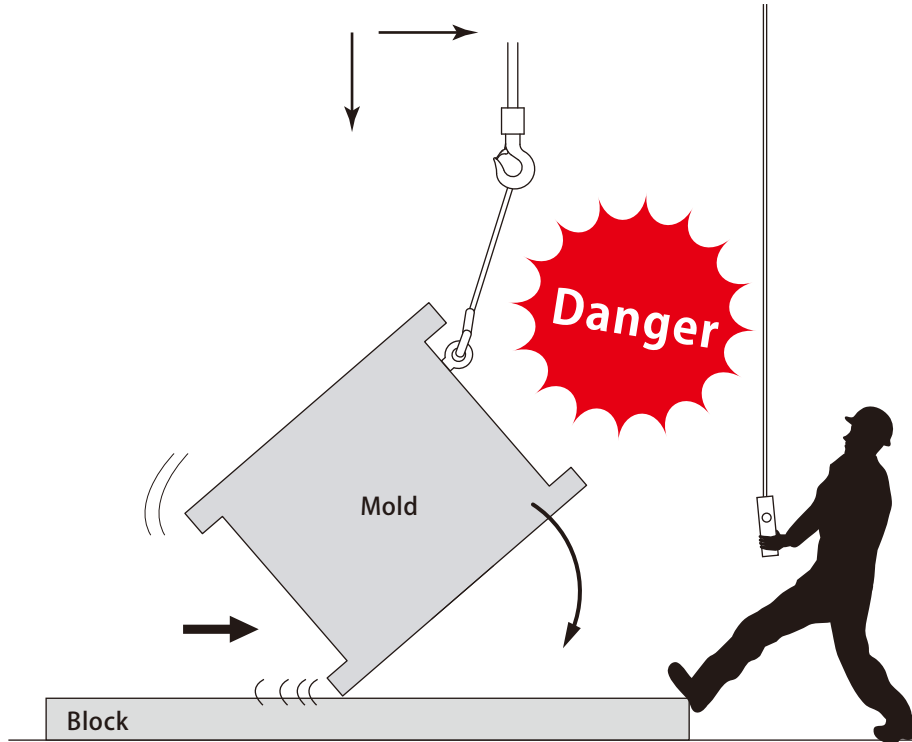

Hoisting up/down operation is required while sliding the crane

Most of the supplier of overhead crane prohibits users from rotating a heavy materials because it is unsafe action. In case of the accident caused by the neglect of the warning of the supplier, the employer may be accused for the oversight of the employee's risky behavior.

The Industrial Safety and Health Act provides that an employer must take the necessary measures to prevent the danger of machinery and equipment in order to ensure the safety of employees. Also the Labor Contract Act mandates the employer to give the employees necessary consideration in order to ensure the safety of their lives and bodies. In today's increasingly demanding management responsibility for occupational accidents, with the increasing number of companies adopting safe rotating machines, an employer must realize the bigger penalty will be imposed just in case an accident occurs during dangerous rotating work of heavy materials.

Pascal rotator is operable only when 2 push buttons on operation switch are dpressed at the same time and the operator's safety is ensured by 2 hand operation however Pascal recommends the users to put danger signal while the rotator is in motion.

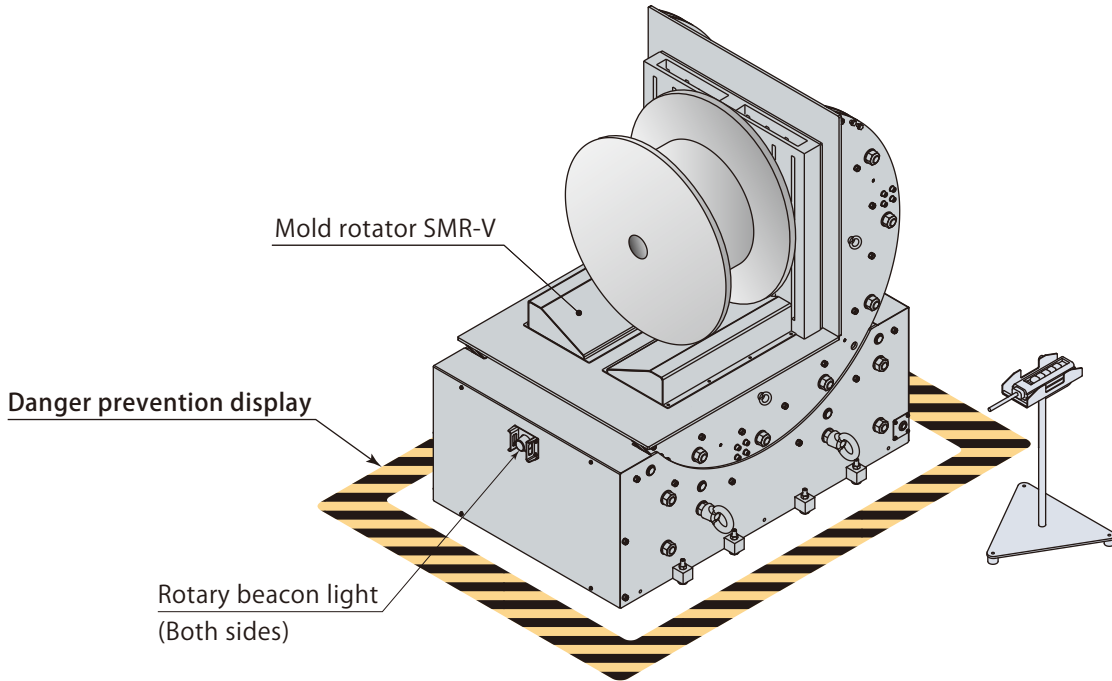

Safety fence (Option ①)

Light curtain (Option ②)

The rotator automatically stops rotating when someone comes in danger zone. Contact Pascal for the details and quotation.

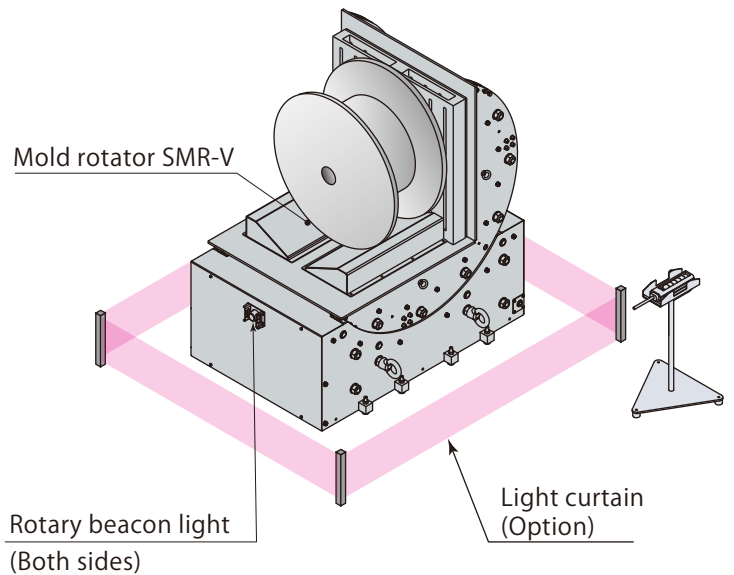
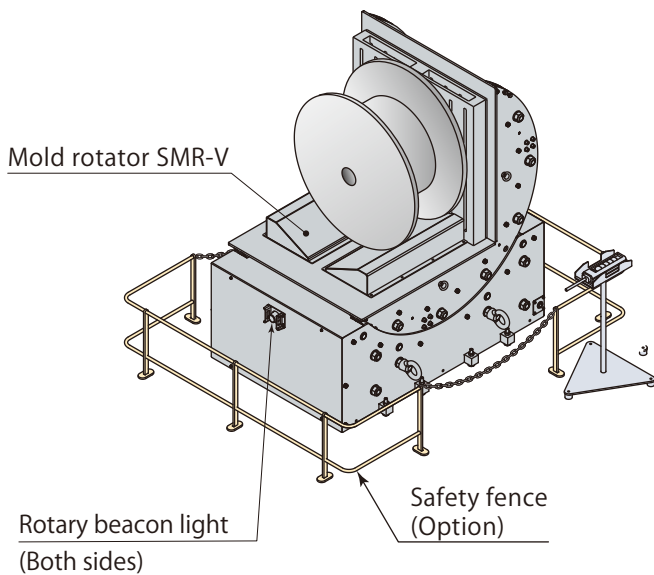

How to use (continued)

■ Lifting/Lowering

⚠ DANGER



Prohibited

- Do not lift more than the capacity. (Fig. E)
The capacity is indicated in the nameplate.
- Do not operate the electric chain hoist exceeding the lifting height.
- Do not dare to lift the structure or any other object supposed to be difficult to lift.
- Do not lift a load at no-load side of the Load Chain.
- Do not stop the electric chain hoist with the limit switch (over winding prevention device).
- Do not use the electric chain hoist when the Friction Clutch (overload prevention device) is operated to stop winding.
- Do not lift or lower excessively.
 - Do not remove the Chain Spring or the Cushion Rubber to operate the limit switch by hitting the body size with the Bottom Hook. If such stop operation is repeated, it may result in breaking of the Load Chain.
 - Do not hit the body size with the End Stopper of the Load Chain to cause the operation of the Friction Clutch. If such operation is repeated, it may result in breaking of the Load Chain.
- Do not use the body size as a fulcrum. (Fig. F)
- Do not swing the lifted load.
- Do not wind the slack Load Chain with a load in one action to avoid exposing the Load Chain to shock.
Stop lifting when the Load Chain is stretched tight. Then lift slowly.
- Do not carry out reverse operation while lifting/lowering a load.
When reversing the motion, stop the electric chain hoist and then reverse the motion.
- Do not carry out excessively frequent inching.
- Do not carry out plugging.
When reversing the motion, stop the electric chain hoist and then reverse the motion.
- When lifting off a load from a pallet, lift the load to avoid exposing to shock, such as the load falling. (Fig. G)
- Do not cause the load to come into contact with the Load Chain.
- Do not rotate a lifted load. Use the device for rotation.
- Do not carry out the welding or cutting work on a lifted load.
- Do not repair or disassemble a lifted load.
When repairing or disassembling an electric chain hoist, ensure that the product is placed down on the floor and that only maintenance engineers maintain the electric chain hoist.
- Do not enter beneath a lifted load.
- Do not hit the Chain Container with a load or slinging devices.
Otherwise the Load Chain in the Chain Container falls out of the bucket to cause injury.

Failure to comply with these instructions may result in death or serious injury.







Mandatory







- When the limit switch (over winding prevention device) is operated, stop the lifting work immediately and lower the load.
- Move the electric chain hoist right above the load and then lift the load. (Do not lift the load in an inclined direction.) (Fig. H)
- Do not leave from the operating position while a load is lifted. Watch the lifted load.

Failure to comply with these instructions may result in death or serious injury.



 Warning	
	<ul style="list-style-type: none"> ● Never attempt to lift a load that exceeds the rated capacity. <ul style="list-style-type: none"> · See the rating plate on the hook block for the rated capacity. ● Do not let anyone ride on or step on the suspended load. <ul style="list-style-type: none"> · Never use the crane to transport or lift a person. ● Stay away from under a suspended load. ● Do not operate the crane if anyone is in the course of the crane motion. ● Do not move over the load above a person. ● Do not leave the operating position while the load is being suspended. <ul style="list-style-type: none"> · Do not operate the crane in a manner that the crane always carries a load. ● Always pay attention to the load while operating the crane. ● Do not operate the crane in a manner that the load or the hook block swings or sways. ● Do not use the limit switch for the over-wind prevention device to stop the lifting operation. ● Do not attempt to lift a load with the hoist not right above the load. <ul style="list-style-type: none"> · Be sure to locate the hoist right above the load before lifting it. ● Do not use the crane to handle a fixed item such as the building structure. ● When lowering a load, do not release the wire rope to the extent that it exceeds the lower limit. <ul style="list-style-type: none"> · Operate the crane in a manner that the wire rope always remains at least two turns on the drum. Do not operate the crane if the wire rope is wound on the drum in the opposite direction. <li style="border: 1px solid red;">● Do not turn over the suspended load in an unsafe manner. <ul style="list-style-type: none"> <li style="border: 1px solid red;">· Use a dedicated turnover device to turn over the suspended load. ● Check the pushbutton for normal action and function before starting to operate the crane. Do not operate the crane if any of the pushbuttons does not operate normally.
 Caution	
	<ul style="list-style-type: none"> ● Operate the crane only from the rated voltage which the crane is designed for. ● Do not apply braking effort by bragging (or rapid reversing the direction). Do not excessively jog the crane. ● Do not let the suspended load caught on other structure or wiring. ● Do not pull on the switch box cable hard with the cable caught on something. ● Never operate the crane beyond the specified duty factor or the allowable number of startup cycles. ● Do not remove the warning or caution labels affixed to the main body. Do not operate the crane with the warning or caution labels left illegible. ● Before releasing the operation box from your hand, put it back to the naturally suspended position. Do not have the operation box hit a person or a thing.
	<ul style="list-style-type: none"> ● Before operating the crane, check that the lower part of the hook rotates smoothly and freely. ● Be sure to engage the sling ropes and sling devices properly with the hook. ● Stop lifting the load once when the wire rope becomes tight. ● Keep clean the operation box so that dust or sand does not collect around the pushbuttons. ● Before releasing the operation box from your hand, put it back to the naturally suspended position. Do not have the operation box hit a person or a thing. ● Make sure that the crane has a sufficient lift for the intended work. ● Be sure to turn off the power before leaving the operating position.

4 Maintenance, inspection and modification

 Danger	
	<ul style="list-style-type: none"> ● Do not use any part or device of the crane beyond its service limit.
 Warning	
	<ul style="list-style-type: none"> ● Never modify any part of the crane or its accessories. ● Never use any part or device other than the specified genuine parts or devices.
	<ul style="list-style-type: none"> ● Be sure to turn off the power before starting maintenance, inspection or repair. ● Only the personnel with the expert knowledge designated by the firm are allowed to maintain, inspect or repair the crane. ● Make sure that the crane is free of a load before starting maintenance, inspection or repair. ● If maintenance or inspection reveals a defect with the crane, do not use the crane until the defects is repaired and rectified. ● Do not use the brake linings beyond its wear limit.
 Caution	
	<ul style="list-style-type: none"> ● Before starting maintenance, inspection or repair, be sure to post or hang proper signs saying “Maintenance in progress” or “NEVER turn on power” for positive indication ● The motors, brake devices and controllers may be very hot. Before starting maintenance, inspection or repair, make sure such devices are safely cool. ● Adjust the brake device to the normal play.

Attention	<ul style="list-style-type: none"> · After reading the instruction manual, keep it at a place available for ready perusal for the personnel involved in the crane. · Be sure to place an order with us for any inspection that involves disassembling and reassembling the crane (refer to the back cover of the instruction manual for the contact details) or with our official dealers.
------------------	--

90 degree rotation type

model **SMR**

For rotating a heavy part or mold

Rotatable weight 1~50 ton

- SMR 01-C 1ton
- SMR 03-C 3ton
- SMR 05-C 5ton
- SMR 10-C 10ton
- SMR 15-C 15ton
- SMR 20-C 20ton
- SMR 30 30ton
- SMR 50 50ton

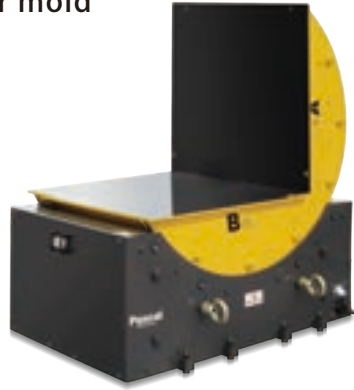

For rotating a coil

model **SMR-V**

Rotatable weight 3~15 ton

- SMR 03-CV 3ton
- SMR 05-CV 5ton
- SMR 10-CV 10ton
- SMR 15-CV 15ton

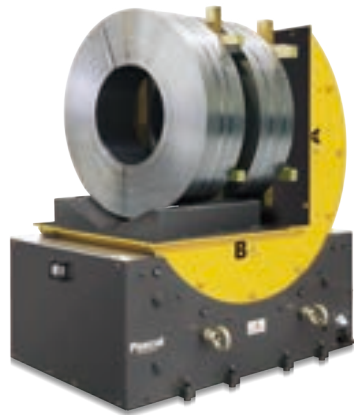

For rotating a cable drum

model **SMR-V**

Rotatable weight 3~15 ton

- SMR 03-CV 3ton
- SMR 05-CV 5ton
- SMR 10-CV 10ton
- SMR 15-CV 15ton



Flat table type 90 degree rotator

model **SMF-M**

For rotating a mold

Rotatable weight 3, 5 ton

SMF 03M 3ton

SMF 05M 5ton



Flat table type 90 degree rotator

model **SMF-H**

For rotating a heavy part or mold

Rotatable weight 10~30 ton

SMF 10H 10ton

SMF 15H 15ton

SMF 20H 20ton

SMF 30H 30ton

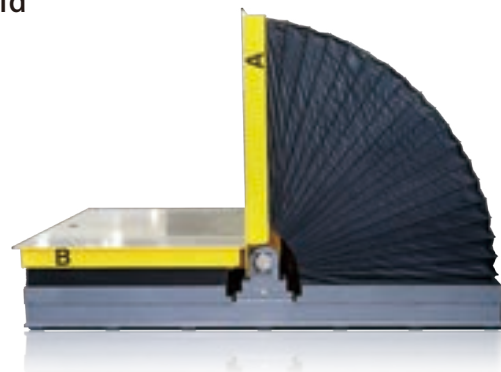

180 degree rotator for a stamping die

model **SMP**



GLOBAL NETWORK

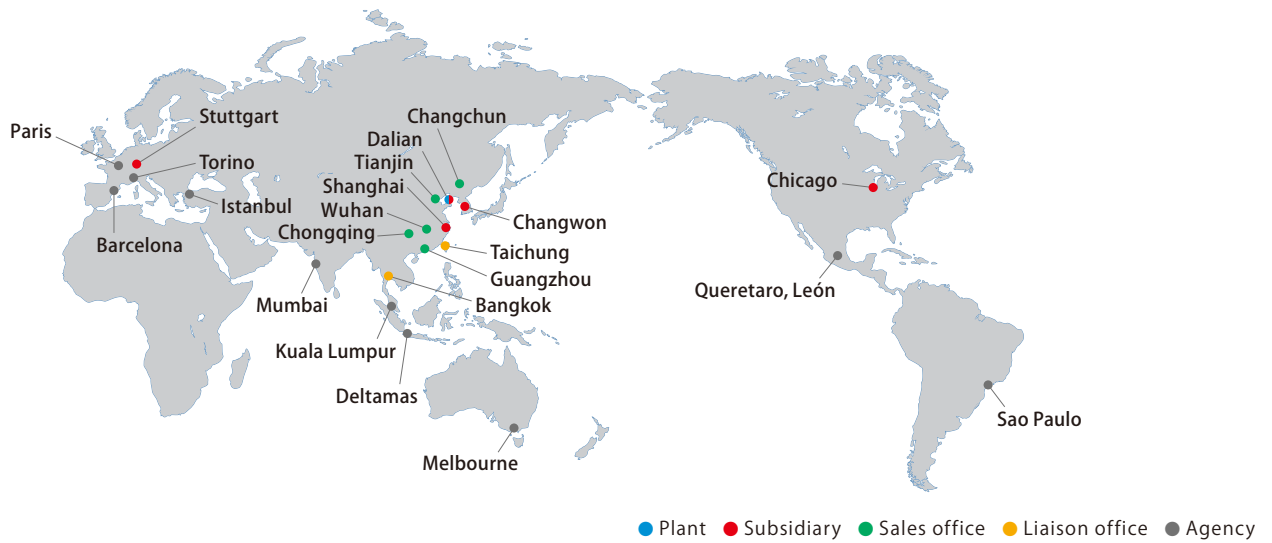

- Chicago (U.S.A.) Subsidiary 64 West Seegers Road Arlington Heights, IL 60005, U.S.A.
TEL. +1-847-427-1234 FAX. +1-847-427-1222
- Stuttgart (Germany) Subsidiary Humboldtstr. 30/32, D-70771 Leinfelden-Echterdingen, Germany
TEL. +49-711-782-850-0 FAX. +49-711-782-850-29
- Dalian (China) Plant / Subsidiary 1F No.100-1, Second Street, DD Port, Dalian Economic and Technological Development Zone, Dalian, Liaoning 116600, P.R.China
TEL. +86-411-8732-2988 FAX. +86-411-8732-7299
- Shanghai (China) Subsidiary 1F, No.3 Office Building, Lane 1199, Jidi Road, Minhang Area, Shanghai 201107, P.R.China
TEL. +86-21-5263-4122 FAX. +86-21-6296-2882
- Changwon (Korea) Subsidiary 1029, 37, Sangnam-ro, Seongsan-gu, Changwon-si, Gyeongsangnam-do 642968, Korea
TEL. +82-55-274-0971 FAX. +82-55-274-0972
- Bangkok (Thailand) Liaison office No.1 MD Tower 15Fl. Unit F, Soi Bangna-Trad 25, Bangna-Trad Rd. Kwang Bangnanua, Khet Bangna, Bangkok 10260, Thailand
TEL. +66-2173-5855 FAX. +66-2173-5857

DOMESTIC LOCATIONS



- Head office / R & D center ... ★ Itami, Hyogo
- Sales office ● Osaka, Hyogo
 ● Kumagaya, Saitama
 ● Atsugi, Kanagawa
 ● Nagoya, Aichi
 ● Yamagata
- Plant ○ Oita
 ○ Yamagata