

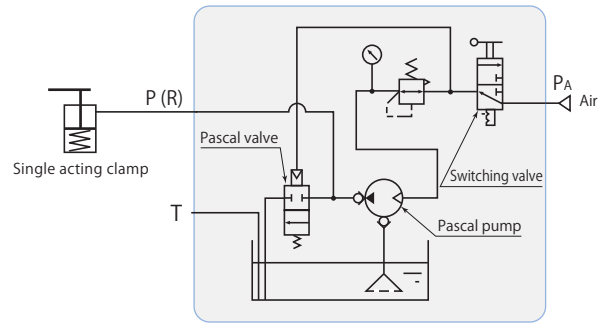

Control unit model HCT-□

Compact hydraulic control unit for air drive and manual operations. Pascal pump stops pumping once circuit pressure has been attained and retains the pressure. Furthermore, since there is hardly any temperature fluctuation of working fluid, there is no need for any auxiliary pressure equipment.



Model	HCT-4	HCT-5
Pascal pump	X6312-HCK-C	X6316-HCK-C
Discharge oil pressure*1	MPa 3.6–10.8	2.25–6.75
Set air pressure	MPa 0.2–0.5	
Unloaded oil discharge amount	L/min Refer to page →235 for performance diagram.	
Tank capacity*2	L H.L. 1.5	L.L. 0.6
Operating temperature	°C 5–60	
Fluid used	General mineral based hydraulic oil (ISO-VG32 equivalent)	
Mass	kg 8.3	

*1: Ask for consultation on specifications that exceed discharge oil pressure range.
 *2: Oil level in the tank should be always between H.L. and L.L. of the gauge.

Dimensions

HCT-□ Single acting circuit control unit

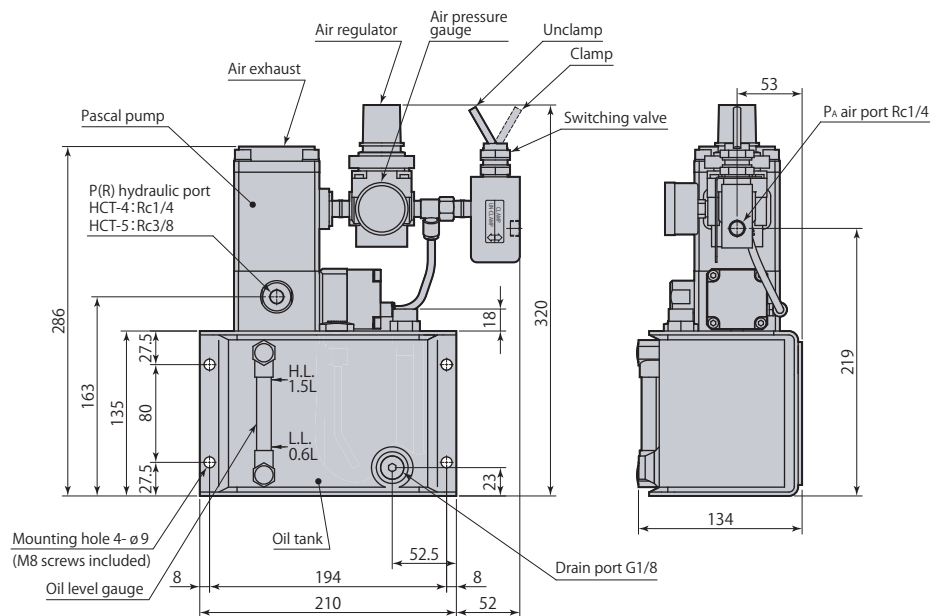
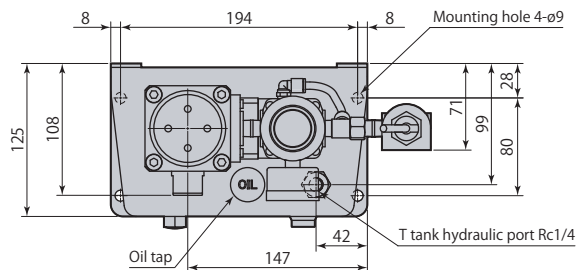

Control unit

HCT Manual operated