

Link clamp Dual cylinder model

model CLP□-□ JP PAT.

Same cylinder force but downsized.  
CLP mounting flange size is equal to that of 2 size smaller CLM.

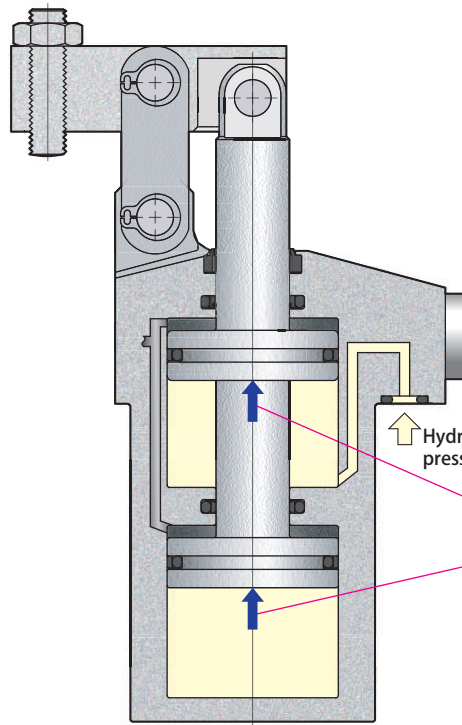

Cylinder force is increased 2.1 times of the force of CLM

Dual cylinder structure

Hydraulic circuit diagram

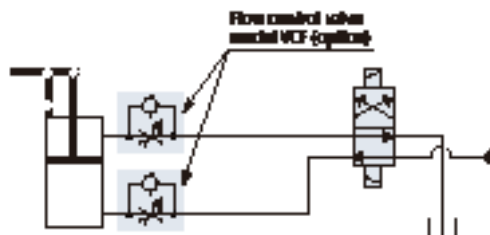

Comparison with the current model

Link clamp  
Dual cylinder model  
**CLP04**

Cylinder force : 3.9kN  
(Hydraulic pressure 3.5MPa)

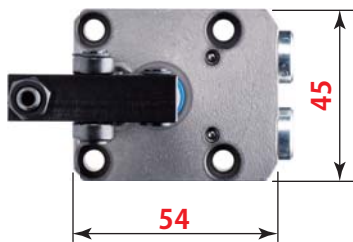

Cylinder force  
Equality

Link clamp  
Compact model  
**CLM06**

Cylinder force : 3.4kN  
(Hydraulic pressure 3.5MPa)

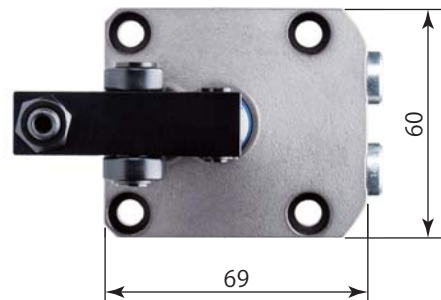

Flange area  
approx. 59%



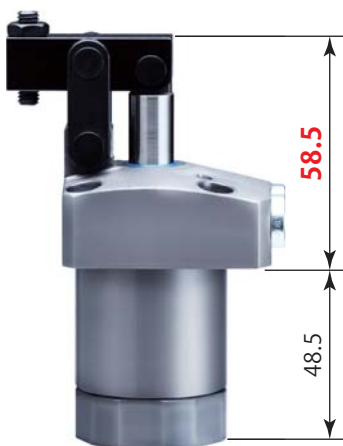

Less space

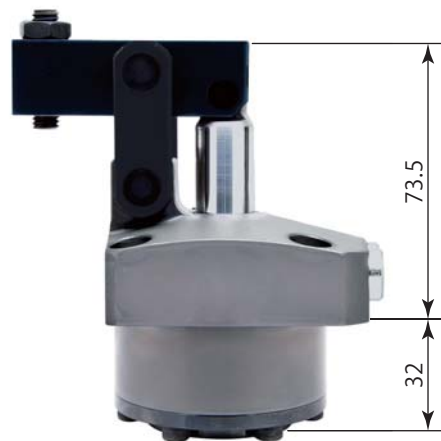

Height from  
mounting surface  
approx. 80%



Specifications

	Size	Clamp arm mounting direction	
CLP	04	L : Left side	
	05	F : Front side	
	06	R : Right side	

Model			CLP04	CLP05	CLP06
Cylinder force (hydraulic pressure 3.5 MPa)		kN	3.9	5.3	7.2
Rod diameter		mm	12	14	16
Effective area (clamp)		cm <sup>2</sup>	11.2	15.0	20.6
Full stroke		mm	19.5	22.5	25
Clamp stroke*1		mm	17.5	20.5	23
Stroke margin		mm	2	2	2
Cylinder capacity	Clamp	cm <sup>3</sup>	21.8	33.8	51.5
	Unclamp	cm <sup>3</sup>	19.6	30.3	46.5
Mass		kg	0.7	1.0	1.5
Recommended tightening torque of mounting screws*2 N·m			7	7	12

- Pressure range: 1~4 MPa    ● Proof pressure: 6 MPa    ● Operating temperature: 0~70 °C
- Fluid used: General mineral based hydraulic oil (ISO-VG32 equivalent)
- Seals are resistant to chlorine-based cutting fluid. (not thermal resistant specification)

\*1: Indicates a distance from unclamping position to clamping point.    \*2: ISO R898 class 12.9

When clamping the workpiece, the clamp arm should be situated like the sketch as shown below. (Clamping point)  
Please avoid any non-axial force such as the bending moment toward the piston rod. (Allowable angle ± 3°)

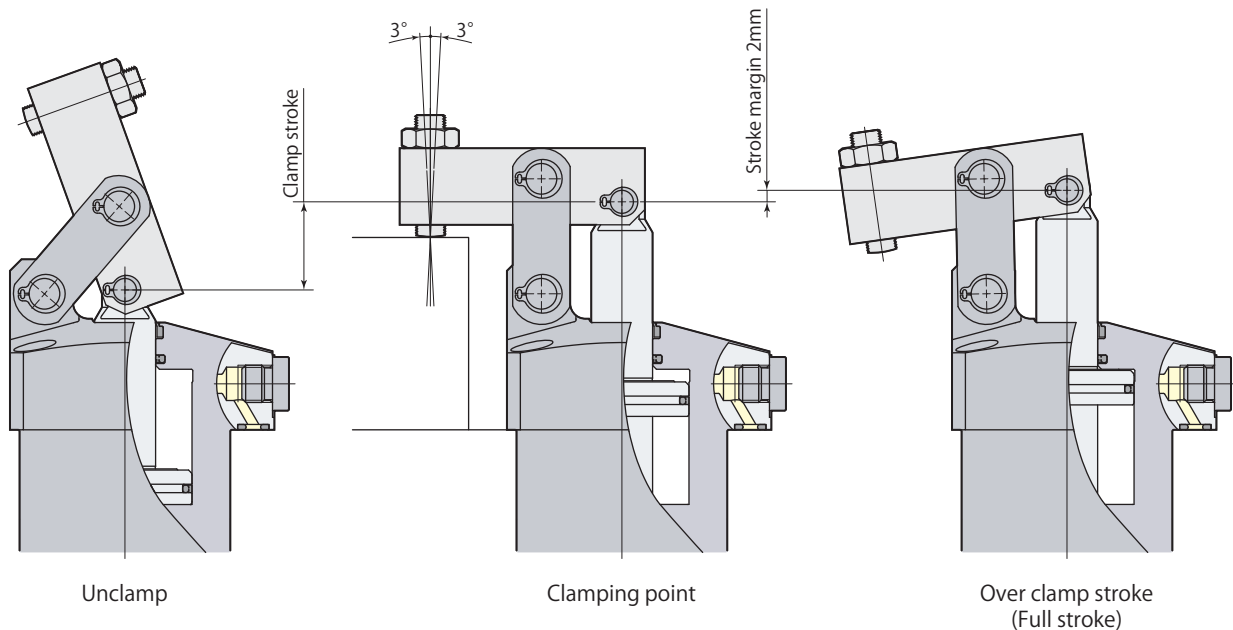

Manifold piping and G port piping are available.

Manifold piping

When choosing manifold piping, a flow control valve (model VCF) and an air bleeding valve (model VCE) are mountable on the G ports of the clamp.

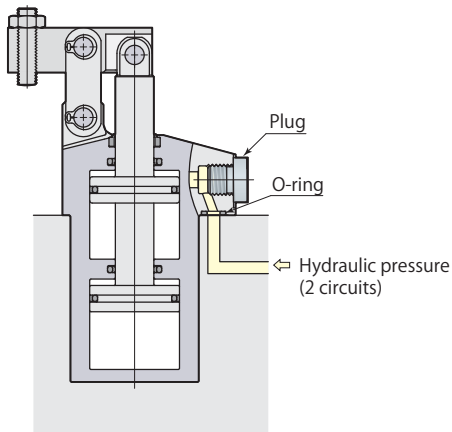

G port piping

Dismount plugs when choosing G port piping. (O-ring must be used.) The flow control valve and the air bleeding valve should be installed in the middle of oil path.

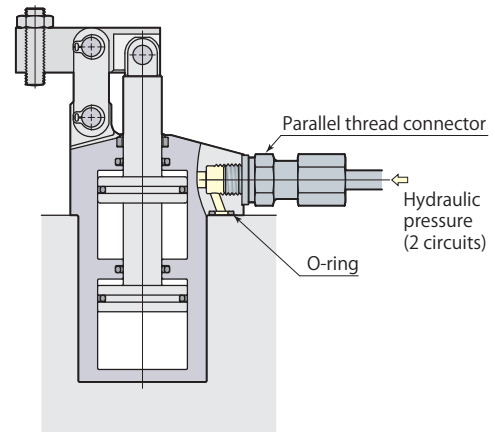

Flow control valve model VCF

Page →27

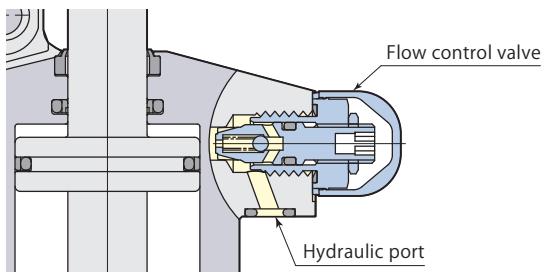

Air bleeding valve model VCE

Page →29

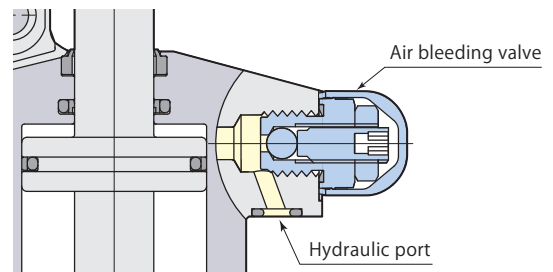

- In case of mounting flow control valve model VCF on the G port of the clamp, air bleeding valve should be installed in the piping to the clamp. (VCE Mounting details. Refer to **page →29**)

Performance diagram

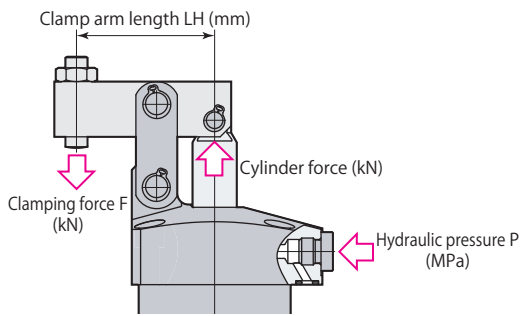

Clamping force varies depending on the clamp arm length (LH) and hydraulic pressure (P).

Clamping force calculation formula

$$F = \text{Coefficient 1} \times P / (\text{LH} - \text{Coefficient 2})$$

F: Clamping force P: Hydraulic pressure LH: Clamp arm length

CLP04 with clamp arm length (LH) = 60 mm at hydraulic pressure of 4 MPa, Clamping force F is calculated by  $16.11 \times 4 / (60 - 16.0) = 1.5 \text{ kN}$

Do not use the clamp in the nonusable range. It may cause damage of link mechanism.

model CLP04

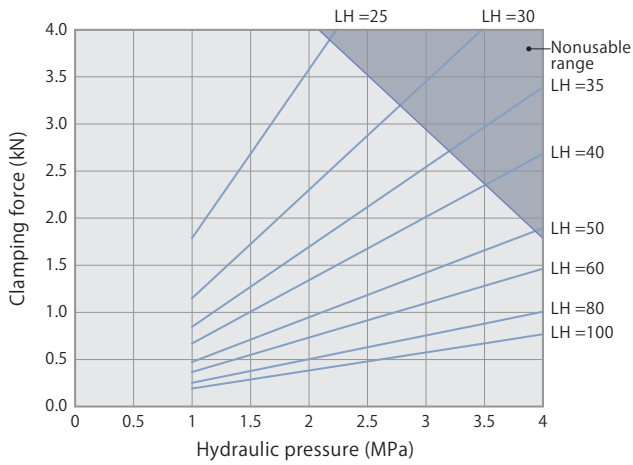

model CLP05

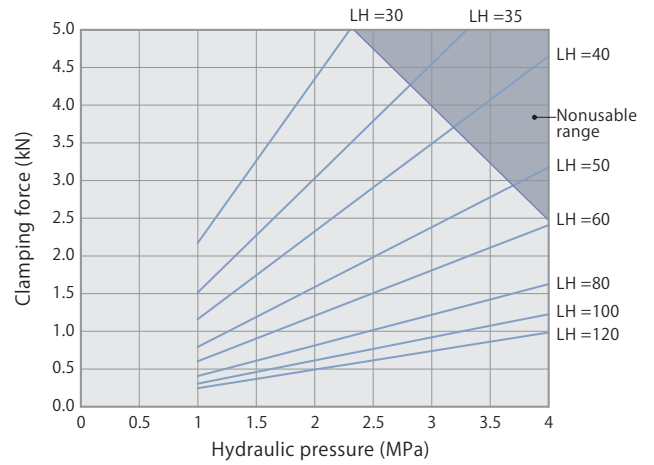

model CLP06

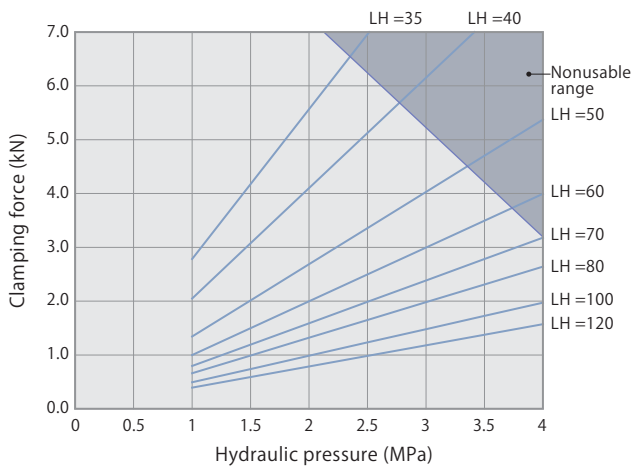

Performance table

**model CLP04** Clamping force  $F=16.11 \times P / (LH-16.0)$

Hydraulic pressure MPa	Cylinder force kN	Clamping force kN								Min. arm length Min. LH mm
		Clamp arm length LH mm								
		25	30	35	40	50	60	80	100	
4	4.5						1.5	1.0	0.8	52
3.5	3.9				2.3	1.7	1.3	0.9	0.7	40
3	3.4			2.5	2.0	1.4	1.1	0.8	0.6	33
2.5	2.8		2.9	2.1	1.7	1.2	0.9	0.6	0.5	28
2	2.2	3.6	2.3	1.7	1.3	0.9	0.7	0.5	0.4	24
1.5	1.7	2.7	1.7	1.3	1.0	0.7	0.5	0.4	0.3	↑
1	1.1	1.8	1.2	0.8	0.7	0.5	0.4	0.3	0.2	24

■ indicates nonusable range

**model CLP05** Clamping force  $F=25.00 \times P / (LH-18.5)$

Hydraulic pressure MPa	Cylinder force kN	Clamping force kN								Min. arm length Min. LH mm
		Clamp arm length LH mm								
		30	35	40	50	60	80	100	120	
4	6.0					2.4	1.6	1.2	1.0	59
3.5	5.3				2.8	2.1	1.4	1.1	0.9	46
3	4.5			3.5	2.4	1.8	1.2	0.9	0.7	38
2.5	3.8		3.8	2.9	2.0	1.5	1.0	0.8	0.6	32
2	3.0	4.3	3.0	2.3	1.6	1.2	0.8	0.6	0.5	28
1.5	2.3	3.3	2.3	1.7	1.2	0.9	0.6	0.5	0.4	27
1	1.5	2.2	1.5	1.2	0.8	0.6	0.4	0.3	0.2	27

■ indicates nonusable range

**model CLP06** Clamping force  $F=38.95 \times P / (LH-21.0)$

Hydraulic pressure MPa	Cylinder force kN	Clamping force kN								Min. arm length Min. LH mm
		Clamp arm length LH mm								
		35	40	50	60	70	80	100	120	
4	8.2					3.2	2.6	2.0	1.6	69
3.5	7.2				3.5	2.8	2.3	1.7	1.4	53
3	6.2			4.0	3.0	2.4	2.0	1.5	1.2	43
2.5	5.2		5.1	3.4	2.5	2.0	1.7	1.2	1.0	37
2	4.1	5.6	4.1	2.7	2.0	1.6	1.3	1.0	0.8	32
1.5	3.1	4.2	3.1	2.0	1.5	1.2	1.0	0.7	0.6	31
1	2.1	2.8	2.1	1.3	1.0	0.8	0.7	0.5	0.4	31

■ indicates nonusable range

Dimensions

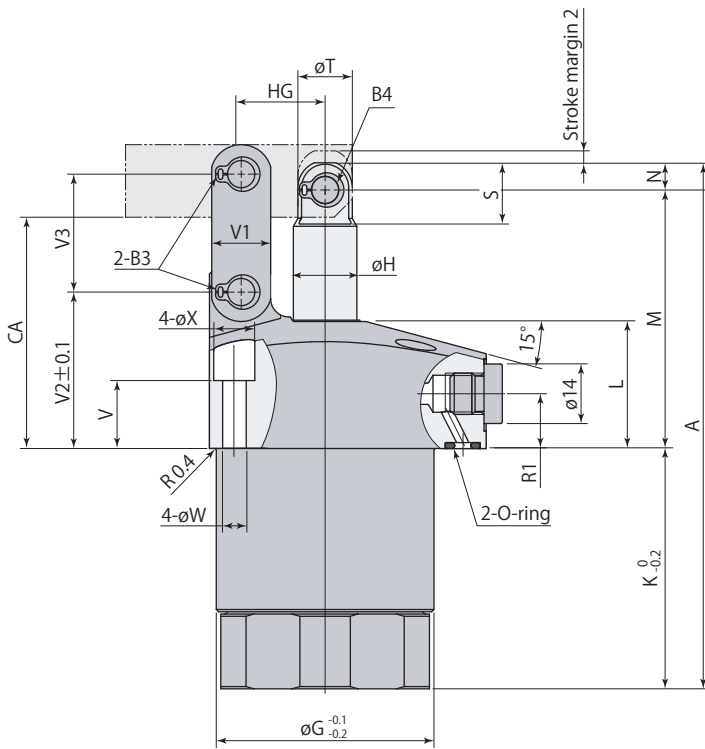
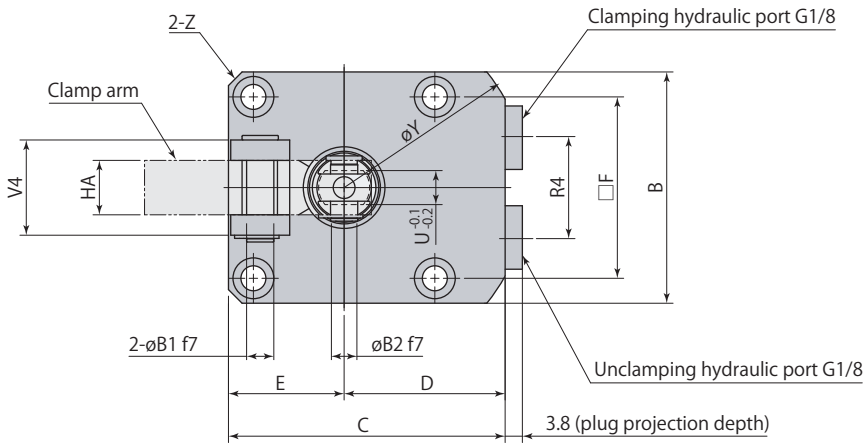

Clamp

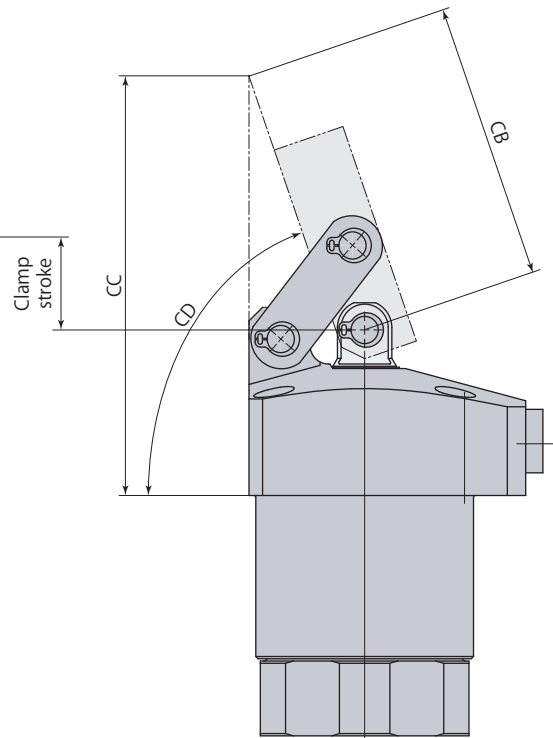

Unclamp

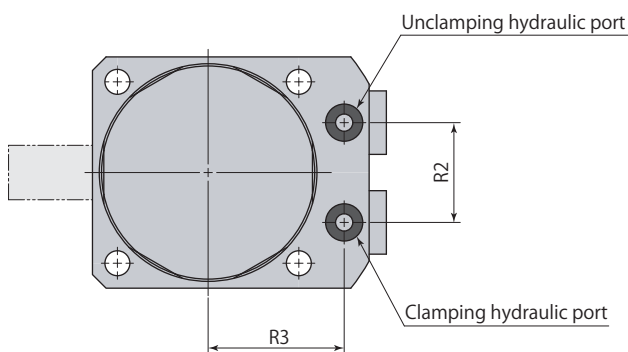

● This diagram represents external contour of CLP□-F. CLP□-L and CLP□-R differ only in terms of mounting direction of clamp arm and otherwise all dimensions are identical to those of CLP□-F.

L: Left side F: Front side R: Right side

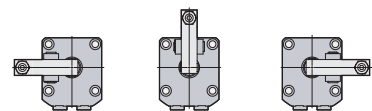

● Clamp arm and mounting screws are not included.

		mm		
Model	CLP04-□	CLP05-□	CLP06-□	
A	104	116	131	
B	45	51	60	
C	54	61	69	
D	31.5	35.5	39	
E	22.5	25.5	30	
F	34	40	47	
øG	40	48	55	
øH	12	14	16	
K	48.5	53	65.5	
L	25	28	28	
M	50	57	59.5	
N	5.5	6	6	
R1	11	12	12	
R2	18	22	24	
R3	26	30	33.5	
R4	20	22	24	
S	12	13.5	13.5	
øT	11	12	12	
U (width across flats)	6	6	8	
V	15.5	16.5	13.5	
V1	11	13	15	
V2	30.5	34.5	35.5	
V3	22	26	30	
V4	21	21	28	
øW	5.5	5.5	6.8	
øX	9	9	11	
øY	72	81	88	
Z	C3	C3	C3.5	
øB1	6 <sup>-0.010</sup> <sub>-0.022</sub>	6 <sup>-0.010</sup> <sub>-0.022</sub>	8 <sup>-0.013</sup> <sub>-0.028</sub>	
øB2	6 <sup>-0.010</sup> <sub>-0.022</sub>	6 <sup>-0.010</sup> <sub>-0.022</sub>	6 <sup>-0.010</sup> <sub>-0.022</sub>	
B3 (snap ring)*	STW-6	STW-6	STW-8	
B4 (snap ring)*	STW-6	STW-6	STW-6	
CA	44.5	51	53.5	
CB	50.2	61.2	71.7	
CC	77.7	92.4	101.9	
CD	About 70°	About 71°	About 70°	
HA	12	12	16	
HG	16	18.5	21	
O-ring (fluorocarbon hardness Hs90)	P5	P5	P5	
Flow control valve	Meter-in	VCF01S	VCF01S	VCF01S
	Meter-out	VCF01S-O	VCF01S-O	VCF01S-O
Air bleeding valve	VCE01	VCE01	VCE01	

\*: Snap ring is made by Ochiai Corporation.

Refer to each page for the details of options.

● Flow control valve **page →27** ● Air bleeding valve **page →29**



Mounting details

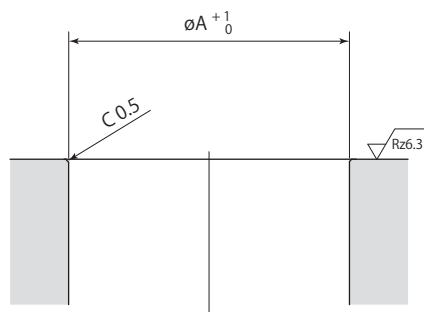
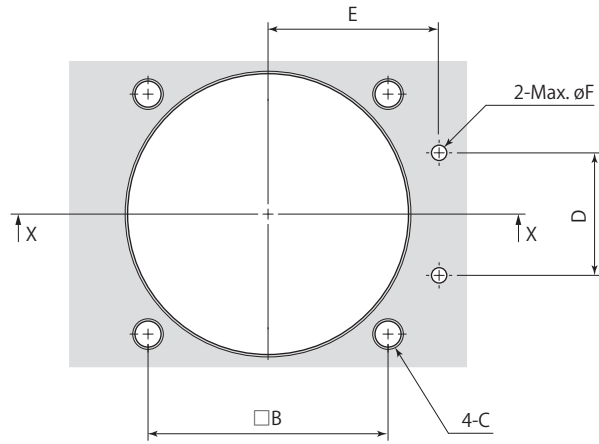

X-X

Model	CLP04-□	CLP05-□	CLP06-□
$\varnothing A$	40	48	55
B	34	40	47
C	M5	M5	M6
D	18	22	24
E	26	30	33.5
$\varnothing F$	3	3	3

mm

### Clamp arm details

Clamp arm is not included. Manufacture a clamp arm with the dimensions shown in the table below.

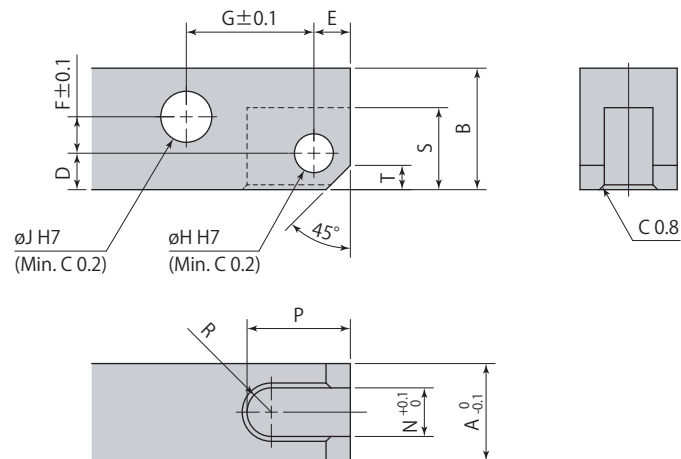

Recommended material: S45C (HB167~229)

Link clamp	CLP04-□	CLP05-□	CLP06-□
A	12	12	16
B	14	16	20
D	5.5	6	6
E	5.5	6	6
F	2.5	3.5	6
G	16	18.5	21
$\varnothing H$	$6^{+0.012}_0$	$6^{+0.012}_0$	$6^{+0.012}_0$
$\varnothing J$	$6^{+0.012}_0$	$6^{+0.012}_0$	$8^{+0.015}_0$
N	6	6	8
P	14.5	17	17
R	R3	R3	R4
S	12	13.5	13.5
T	3	4	4

● When mounting the clamp arm, use included pins and snap rings.

### Clamp arm allowable eccentricity

An eccentric shape clamp arm, as shown in diagram on right can be used with link clamp model CLP, if it is not possible to set clamping point at tip section of clamp arm in alignment with center line of piston rod and clamp arm.

Amount of eccentricity, however, must be within allowable eccentricity shown below.

Using a clamp arm that exceeds allowable eccentricity results in significant eccentric load on link mechanism and piston rod, leading to malfunction.

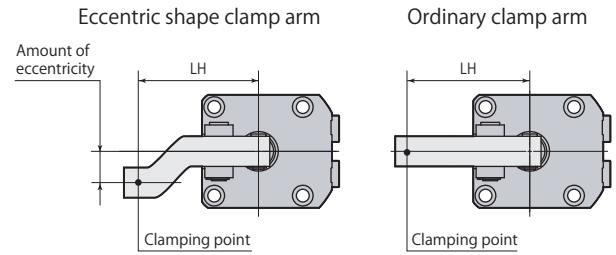

model CLP04		■ indicates nonusable range							
Hydraulic pressure MPa	Allowable eccentricity mm								
	Clamp arm length LH mm								
	25	30	35	40	50	60	80	100	
4	■	■	■	■	■	15	26	36	
3.5	■	■	■	5	12	19	31	42	
3	■	■	4	8	16	23	37	50	
2.5	■	2	7	12	21	29	45	60	
2	■	6	11	17	28	38	58	↑	
1.5	3	11	19	26	39	53	60	↑	
1	10	22	32	42	60	60	60	60	

model CLP05		■ indicates nonusable range							
Hydraulic pressure MPa	Allowable eccentricity mm								
	Clamp arm length LH mm								
	30	35	40	50	60	80	100	120	
4	■	■	■	■	5	12	20	27	
3.5	■	■	■	3	7	16	24	31	
3	■	■	■	5	10	20	29	38	
2.5	■	■	2	8	14	26	36	46	
2	■	2	5	13	21	34	47	60	
1.5	1	6	11	21	30	47	60	↑	
1	7	14	22	35	48	60	60	60	

model CLP06		■ indicates nonusable range							
Hydraulic pressure MPa	Allowable eccentricity mm								
	Clamp arm length LH mm								
	35	40	50	60	70	80	100	120	
4	■	■	■	■	2	4	8	12	
3.5	■	■	■	1	3	6	10	15	
3	■	■	■	2	5	8	14	19	
2.5	■	■	1	5	8	11	18	25	
2	■	■	4	8	12	16	25	33	
1.5	■	2	8	13	19	24	36	47	
1	3	7	16	24	33	41	58	74	