

Expansion clamp

扩张型夹紧器 使用例

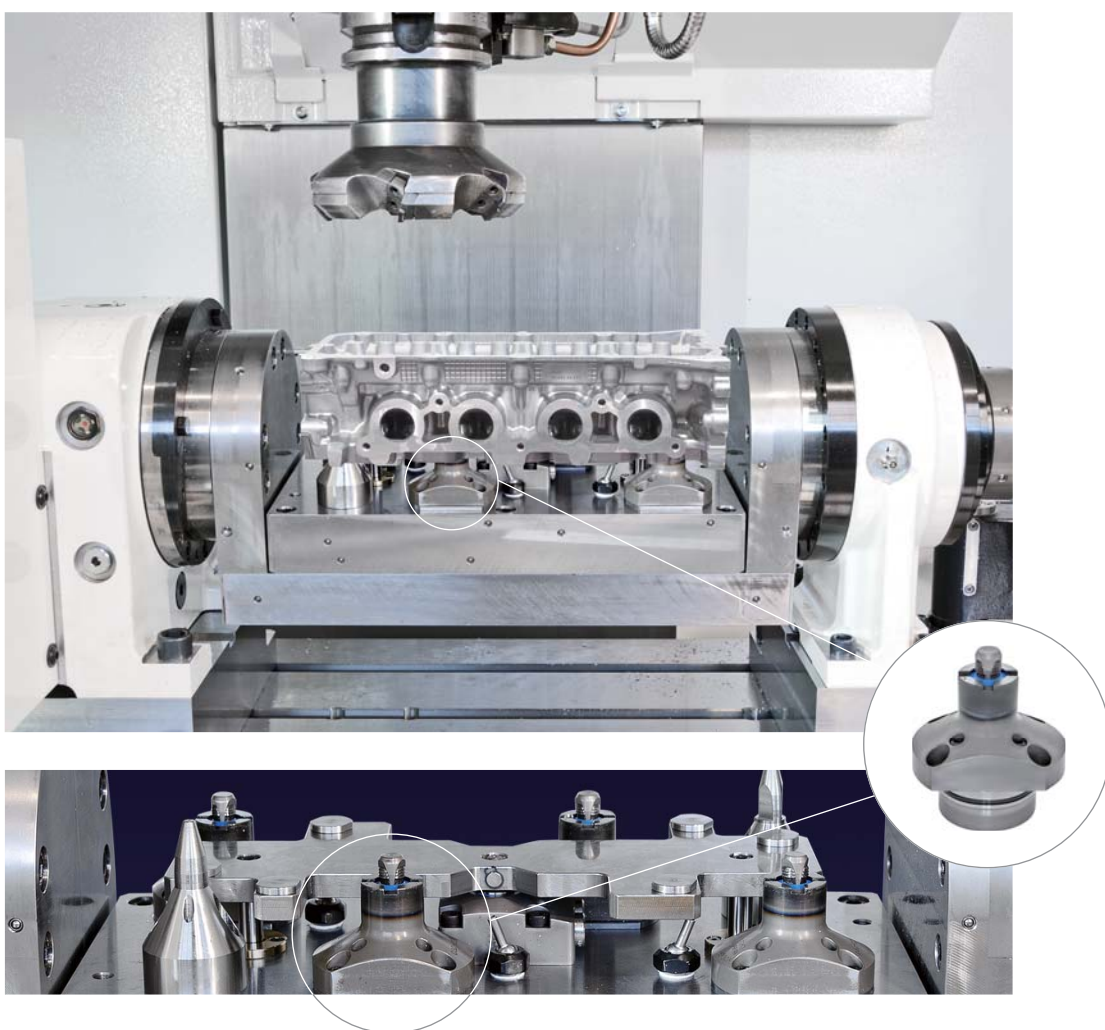



夹具组合

CGC-N22E11×4个

夹孔内经:φ11

夹紧力:12.0 kN

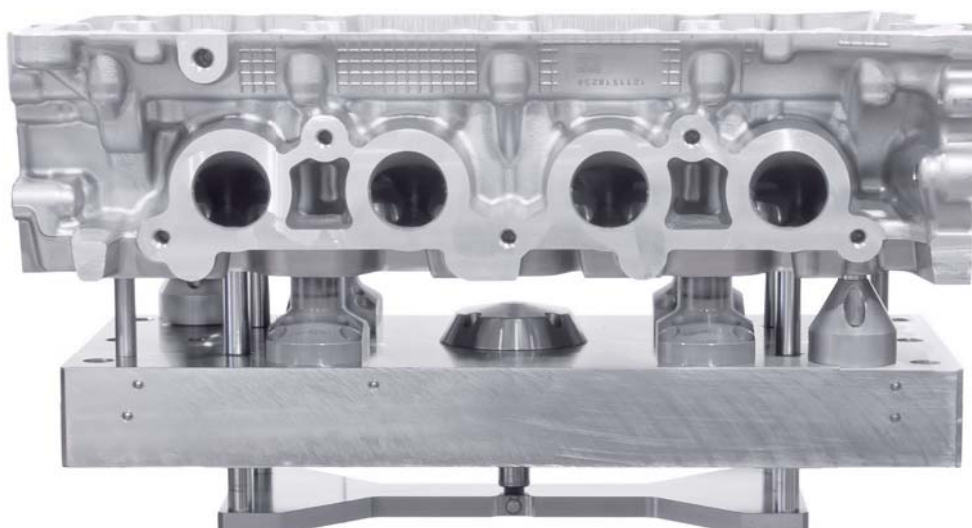

气缸盖

铸铝

425×210×110 mm



夹具组合

CGC-N22E11×4个

夹孔内经:φ11

夹紧力:12.0 kN



气缸体

铸铝

400×210×240 mm



夹具组合

CGC-N22E10×3个

夹孔内经:ø10

夹紧力:9 kN

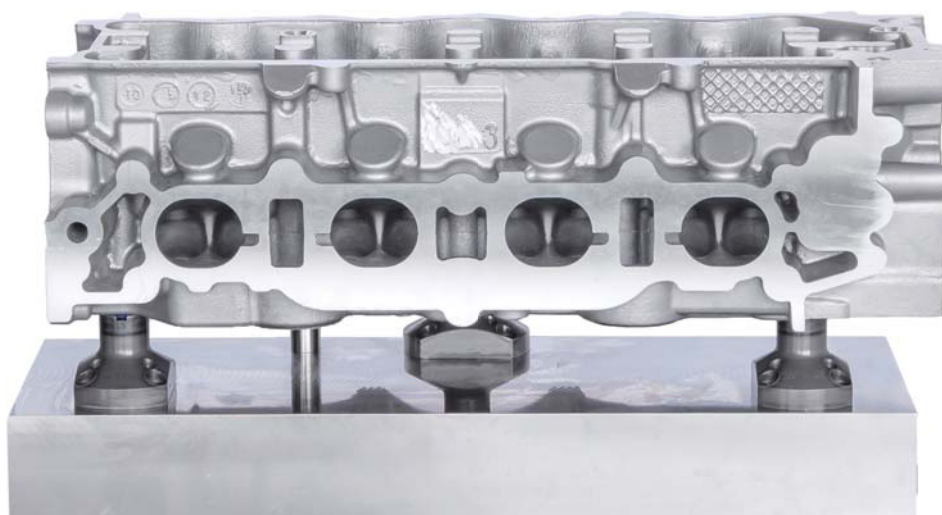

气缸盖

铸铝

410×220×120 mm



夹具组合

CGC-N22E12×4个

夹孔内经:φ12

夹紧力:12 kN



气缸体

铸铝

395×377×203 mm



夹具组合

CGC-N22E11×3个, CSN00LB×2个

夹孔内经:φ11

夹紧力:9.0kN, 工件支撑力:4kN

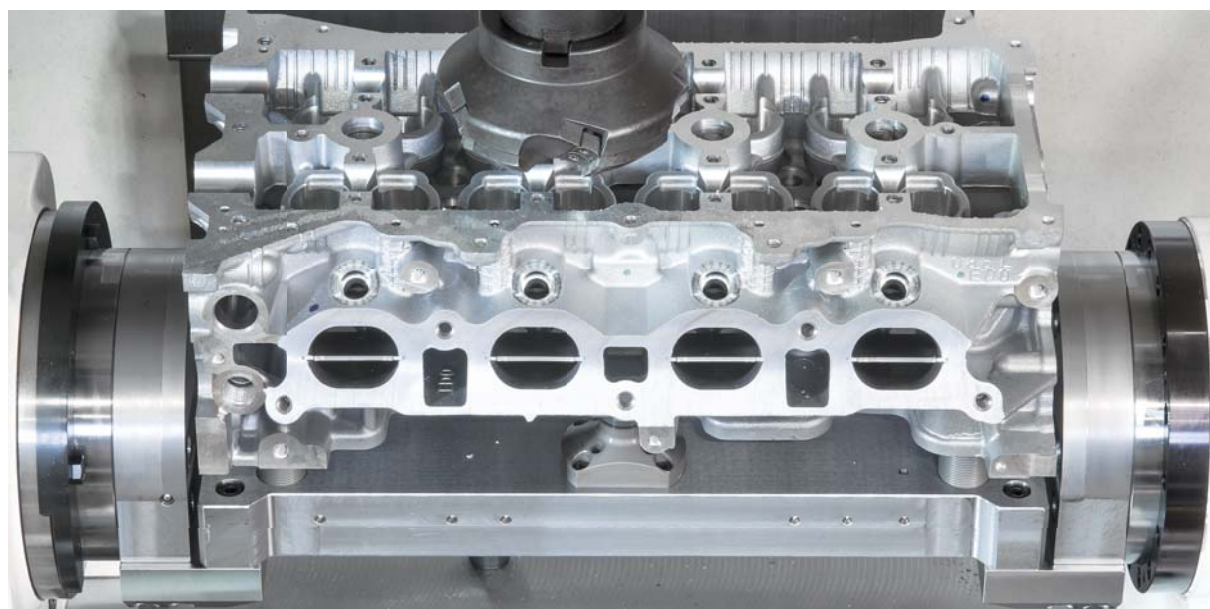

气缸盖

铸铝

414×193×125 mm



加工夹具

CGS-N22E09×3个

夹孔内经:φ9

夹紧力:9.0kN



工件

铸铝

150×150×150 mm

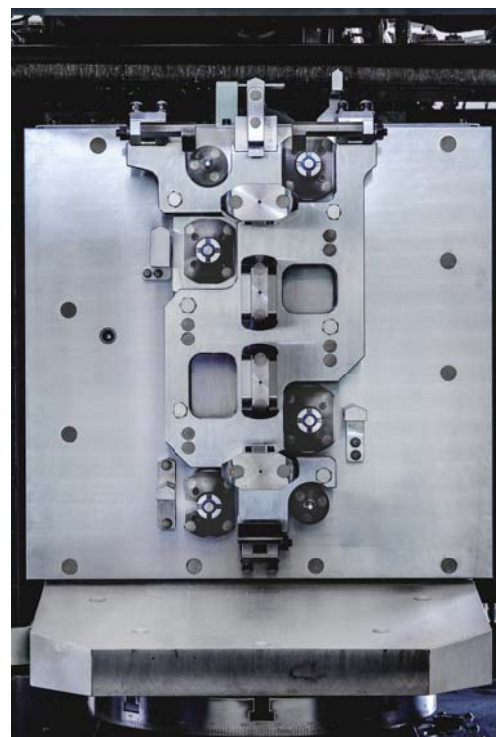
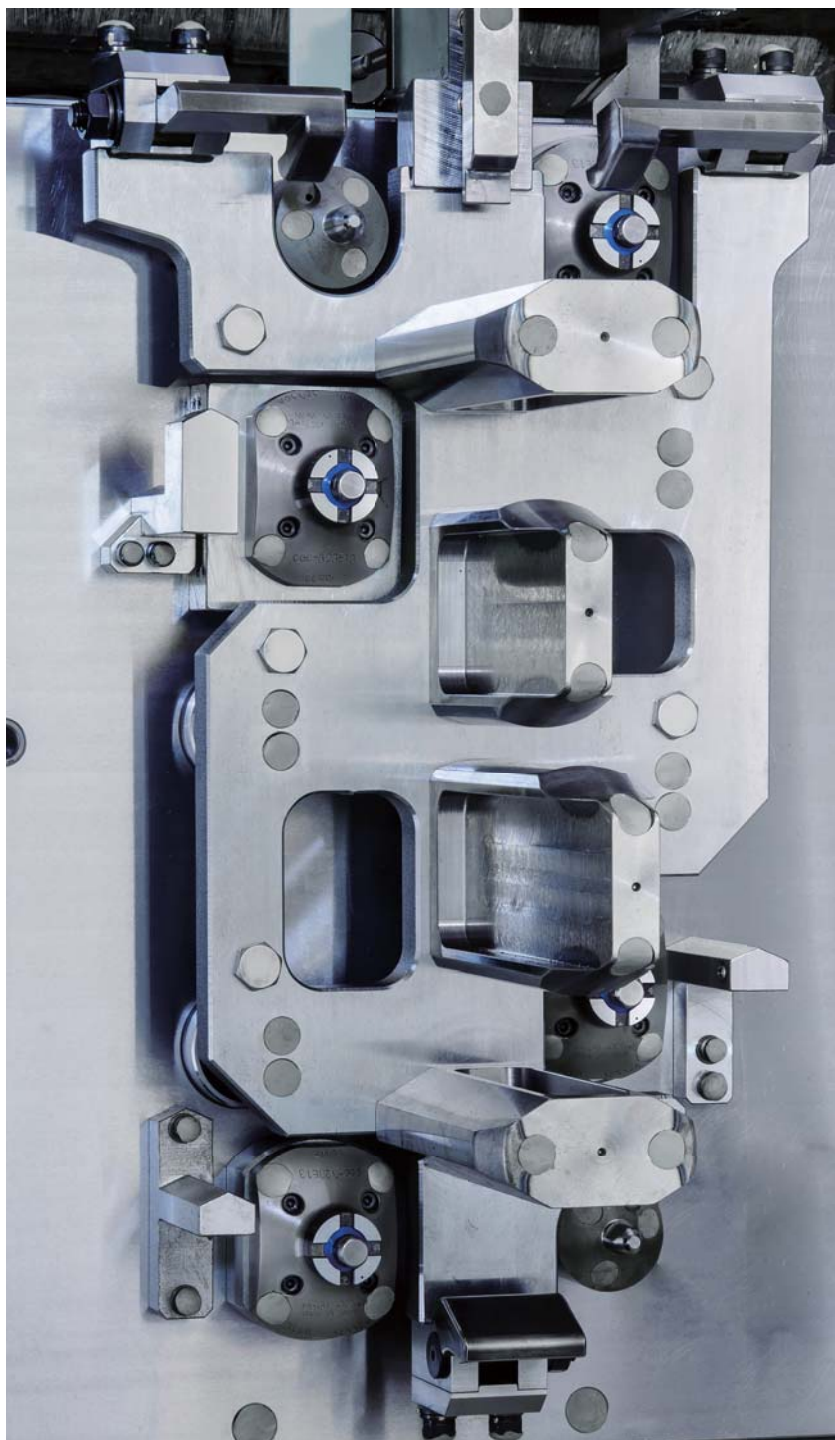

夹具组合

CGC-N23E11×4个

夹孔内经:φ13

夹紧力:30.0kN

气缸体

铸铝

414×193×125 mm

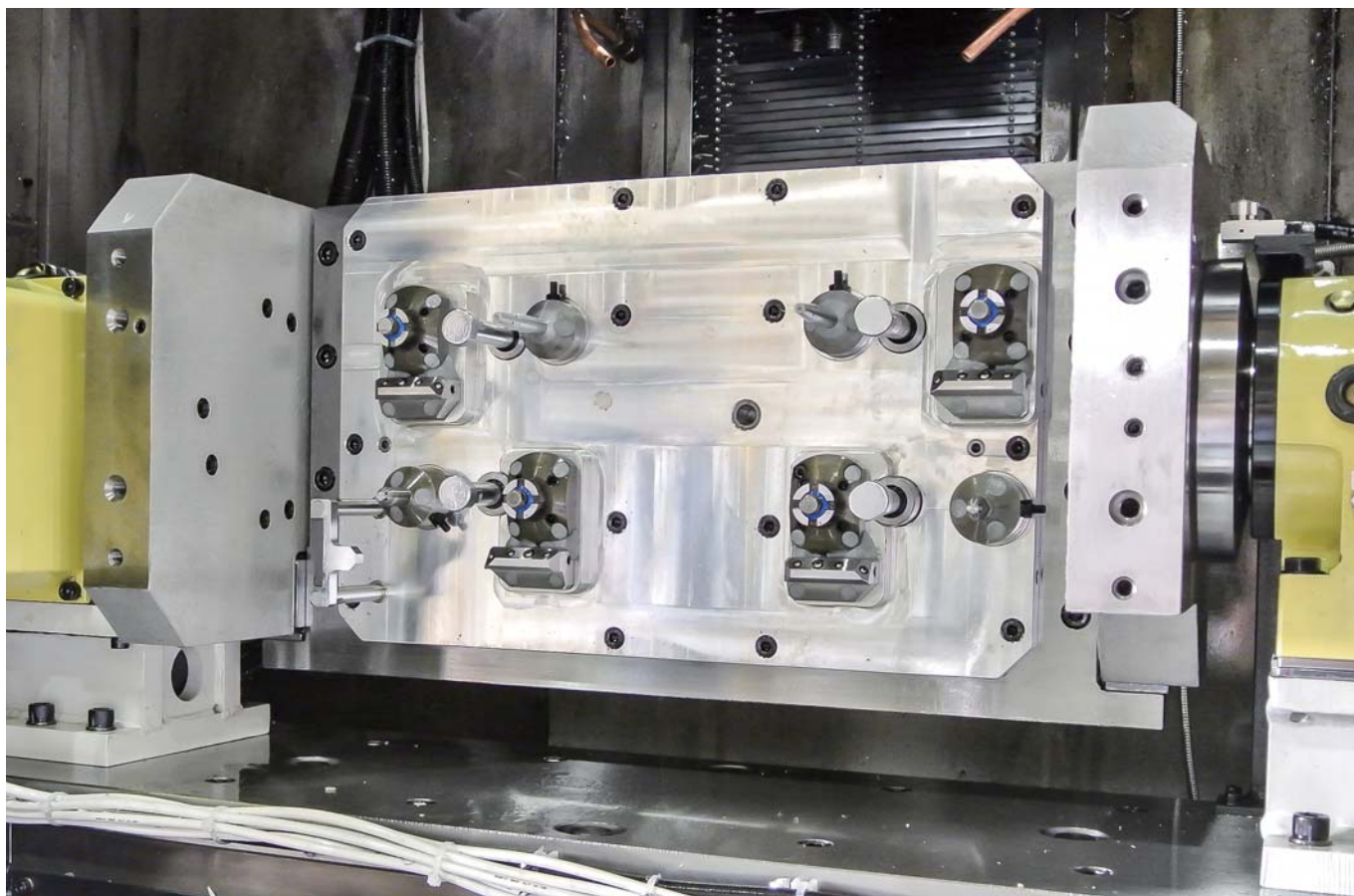

夹具组合

CGC-N22E11×4个

夹孔内经:φ13

夹紧力:10.0kN

气缸盖

铸铝

425×220×110 mm

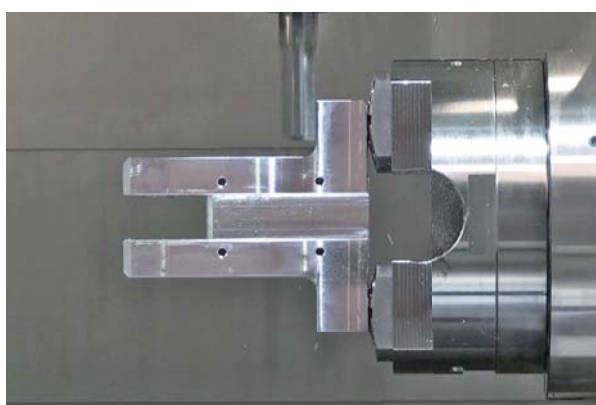
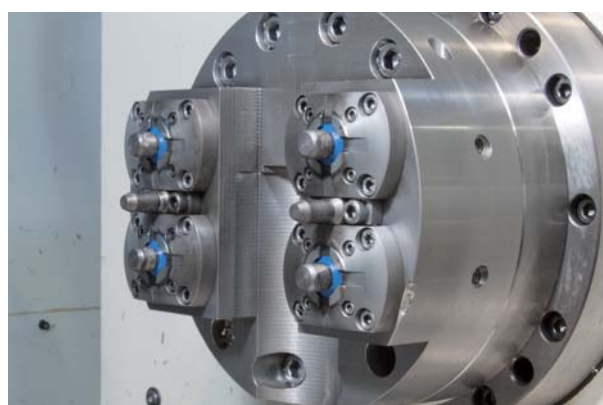
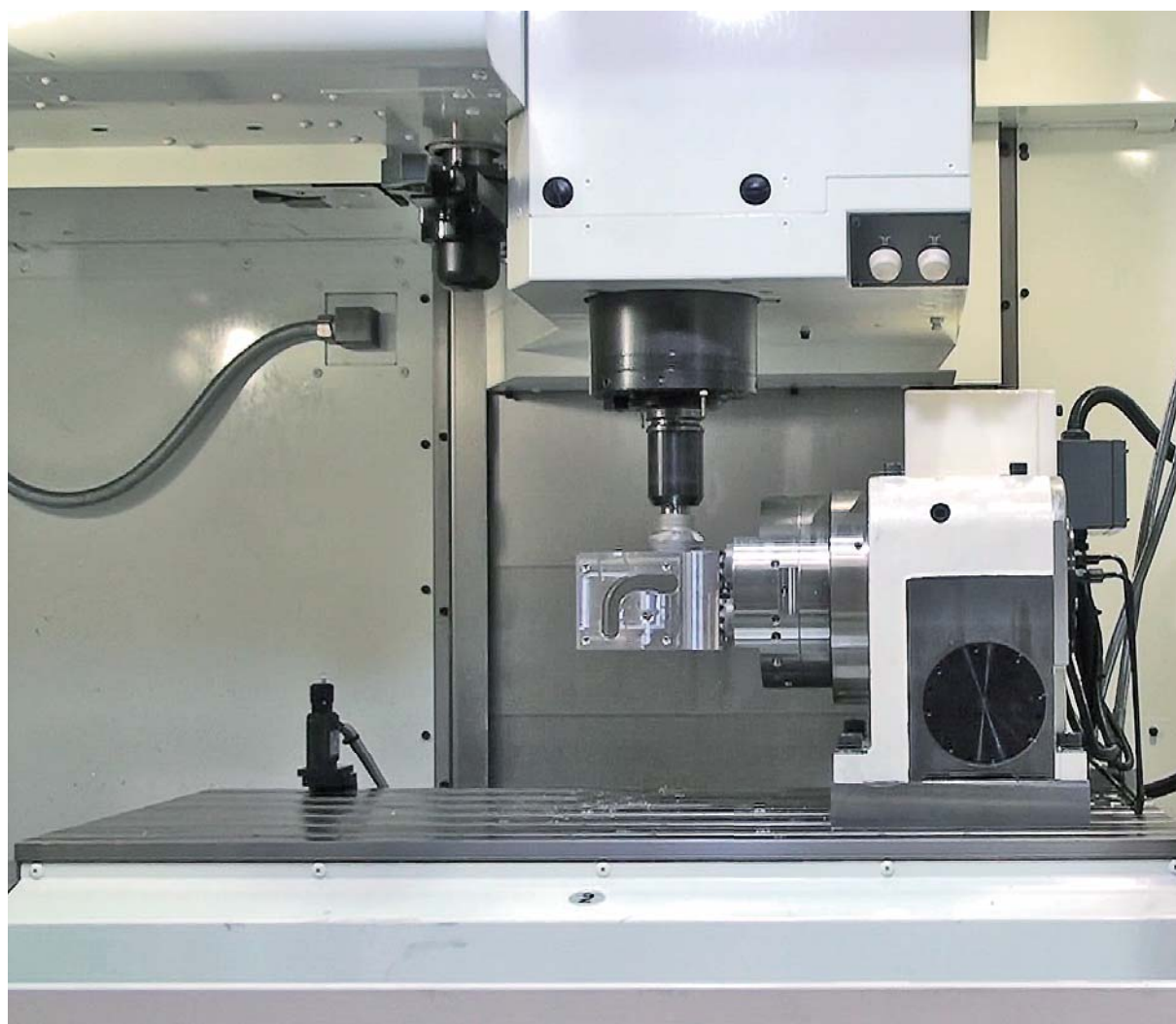

夹具组合

CGS-N22E12×4个

夹孔内经:φ12

夹紧力:14 kN

工件

A2017(硬铝)

200×100×150 mm

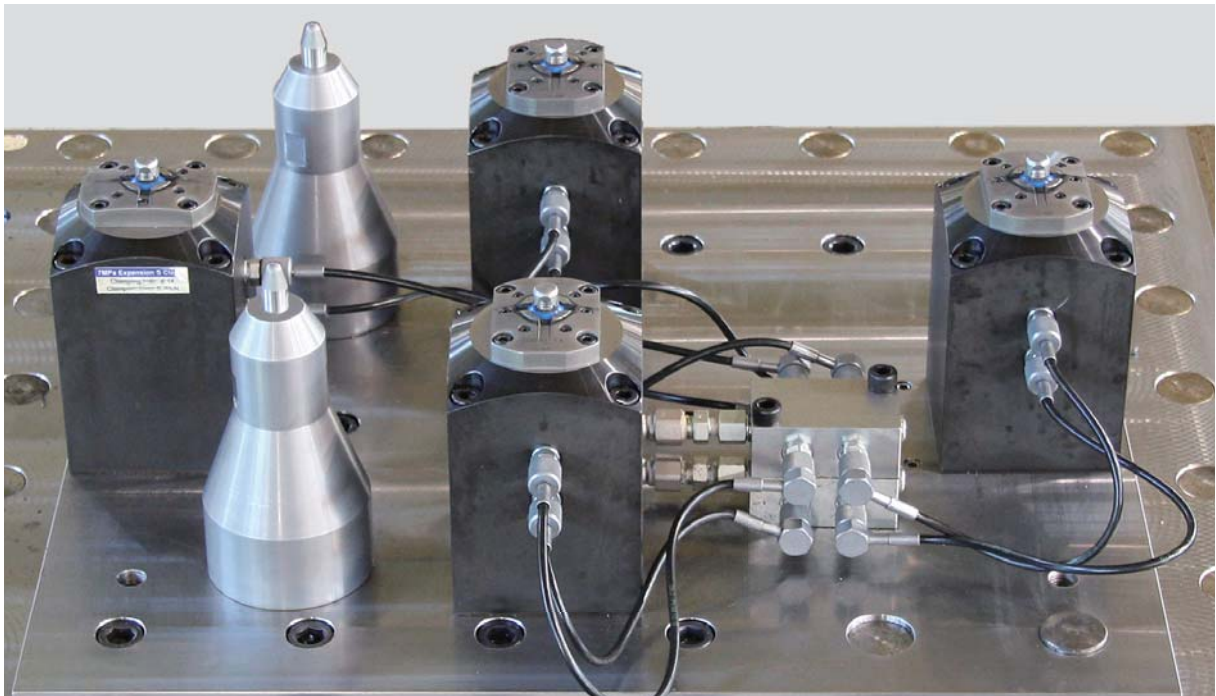

夹具组合

CGS-N23E14×4个

夹孔内经:φ14

夹紧力:29.6 kN

工件

S45C

578×450×60 mm

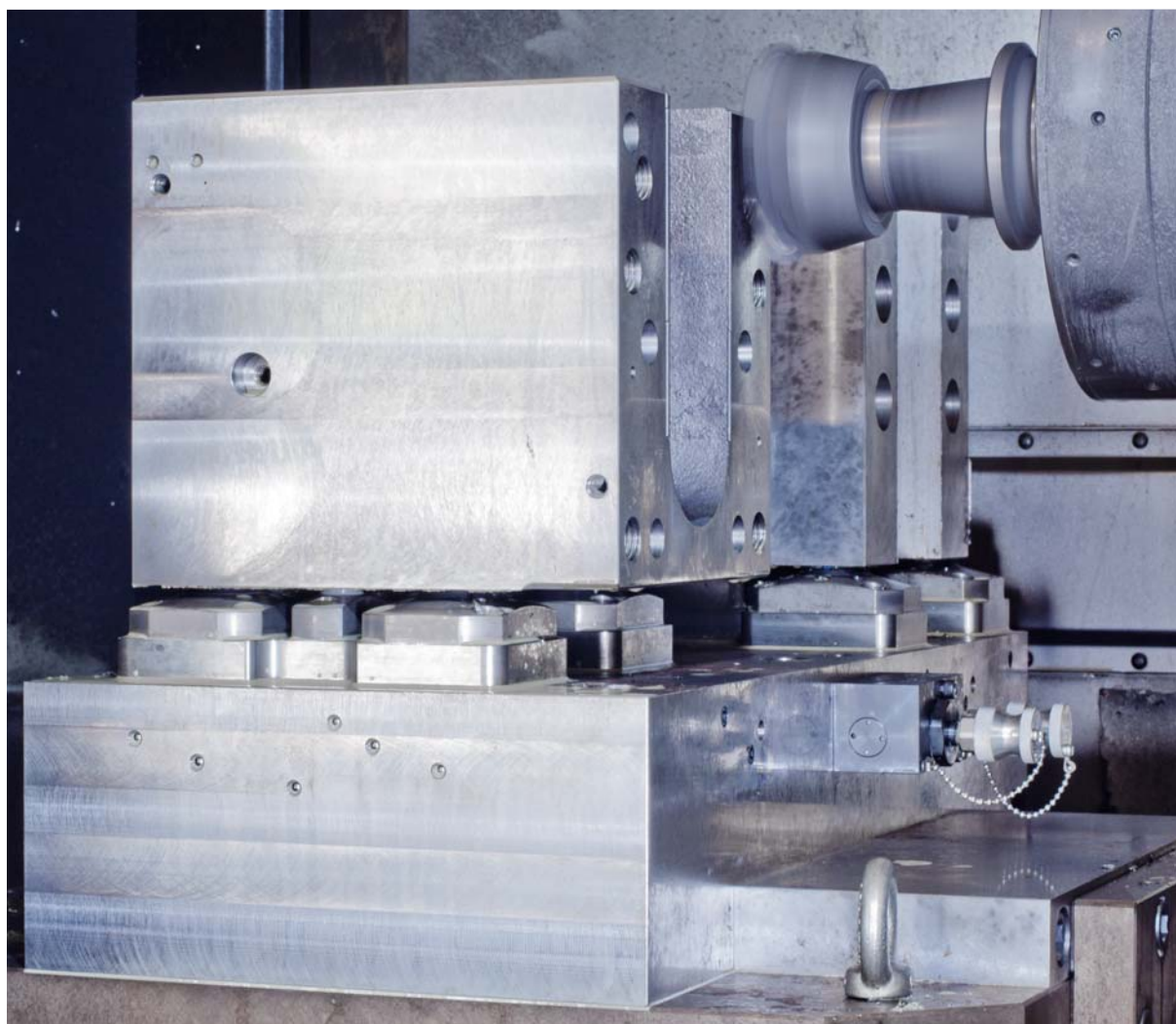

夹具组合

CGS-N24E17×4个

夹孔内经:φ17

夹紧力:54 kN

工件

FCD400

200×200×200 mm

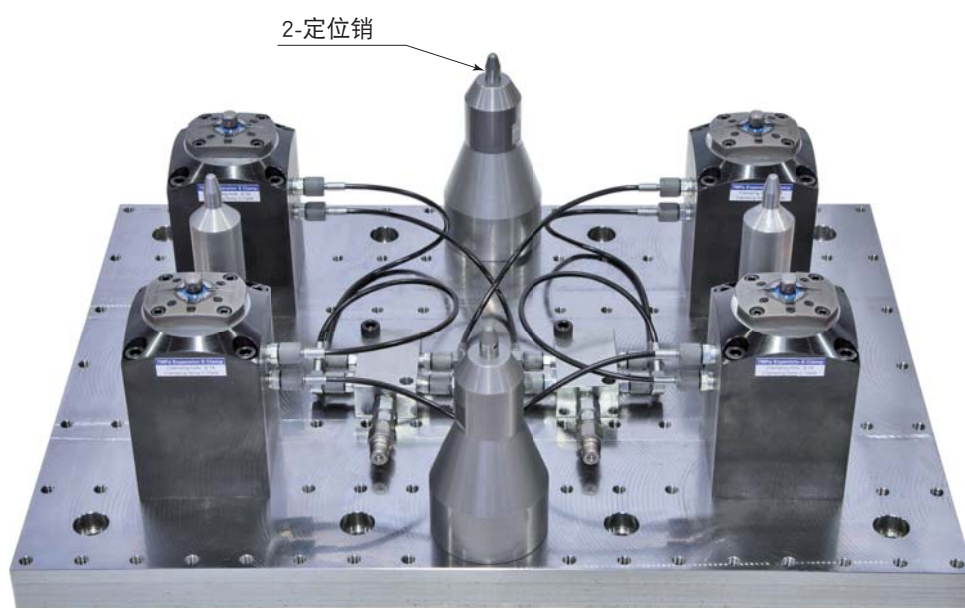

2-定位销

夹具组合

CGS-N23E14×4个

夹孔内经:ø14

夹紧力:29.6 kN

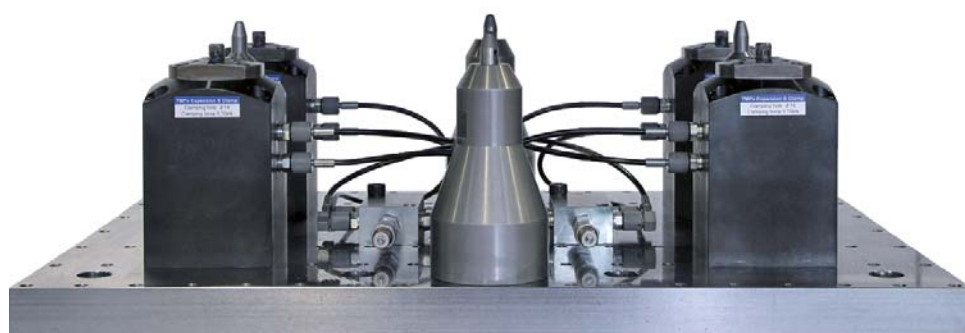

工件

SS400

570×570×50 mm

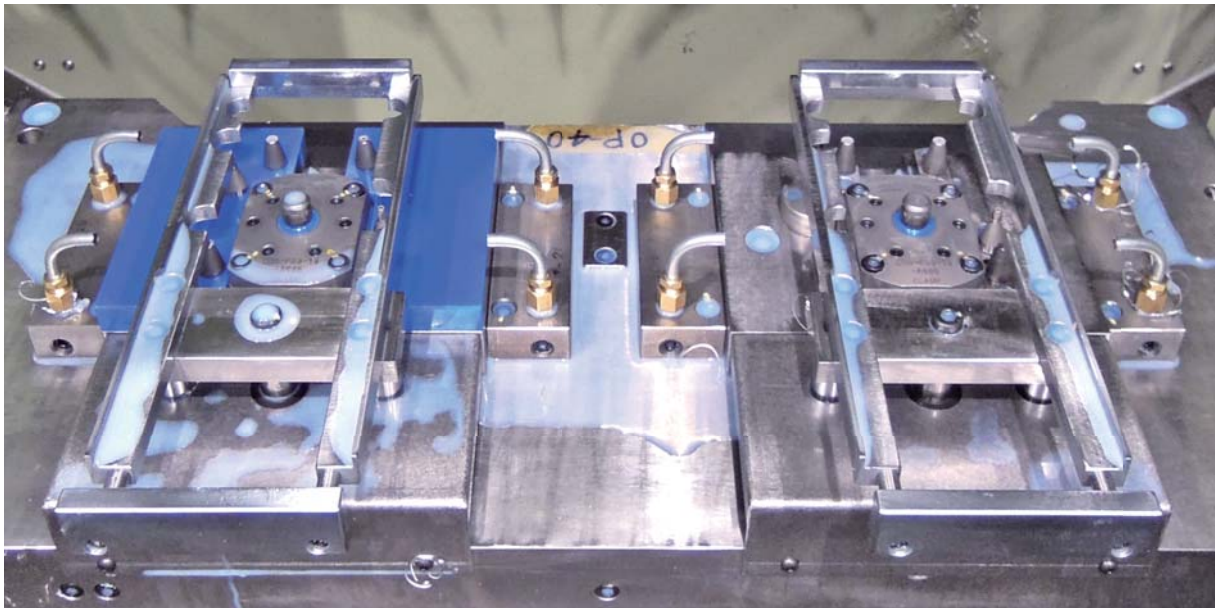

夹具组合

CGS-P23-14×1个

夹孔内经:ø14

夹紧力:5.3 kN

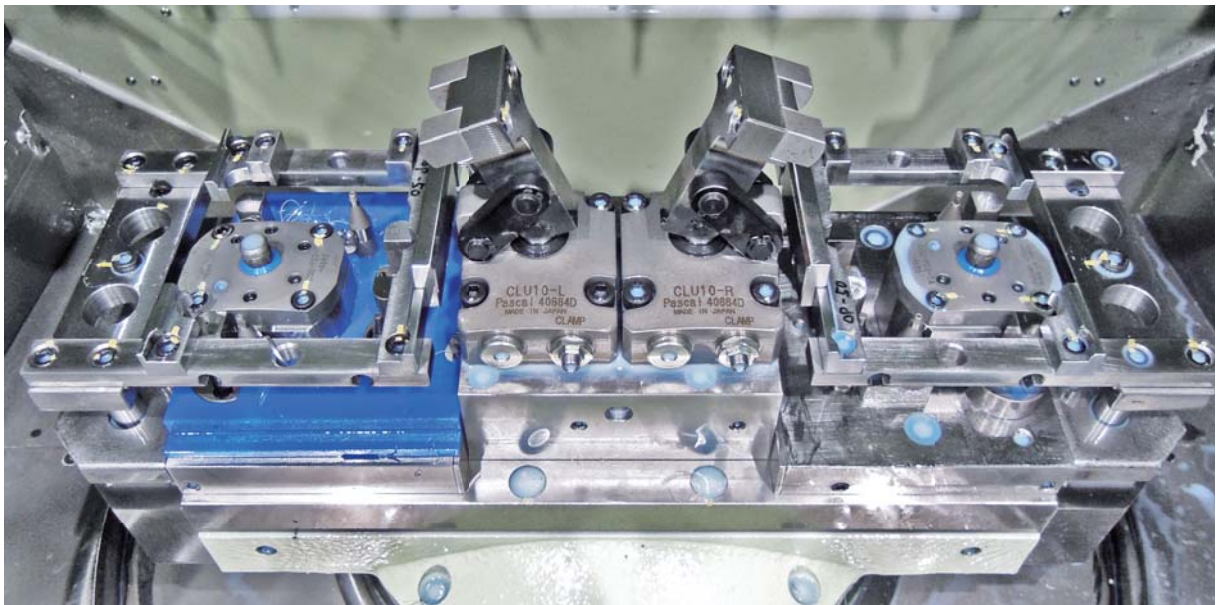

夹具组合

CGS-P23-14×1个 CLU10-L/R×1个

夹孔内经:ø14

夹紧力:10.4 kN



夹具组合

CGS-N22-09×3个

夹孔内经:ø9

夹紧力:6 kN

歧管垫片

AC4BF(铸铝)

200×70×15 mm



夹具组合

CGS-N23-15×4个

夹孔内经:φ15

夹紧力:19.6 kN

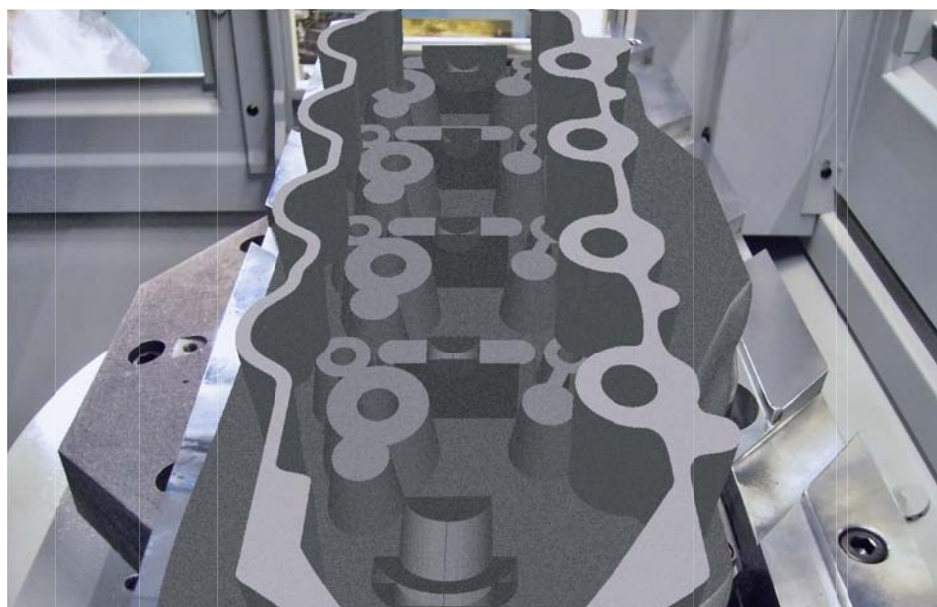

气缸盖

FCD250(铸铁)

500×220×120 mm



夹具组合

CGS-N23-12×3个 CGS-N22-12×1个

夹孔内经: $\varnothing 12$

夹紧力: 19.6 kN

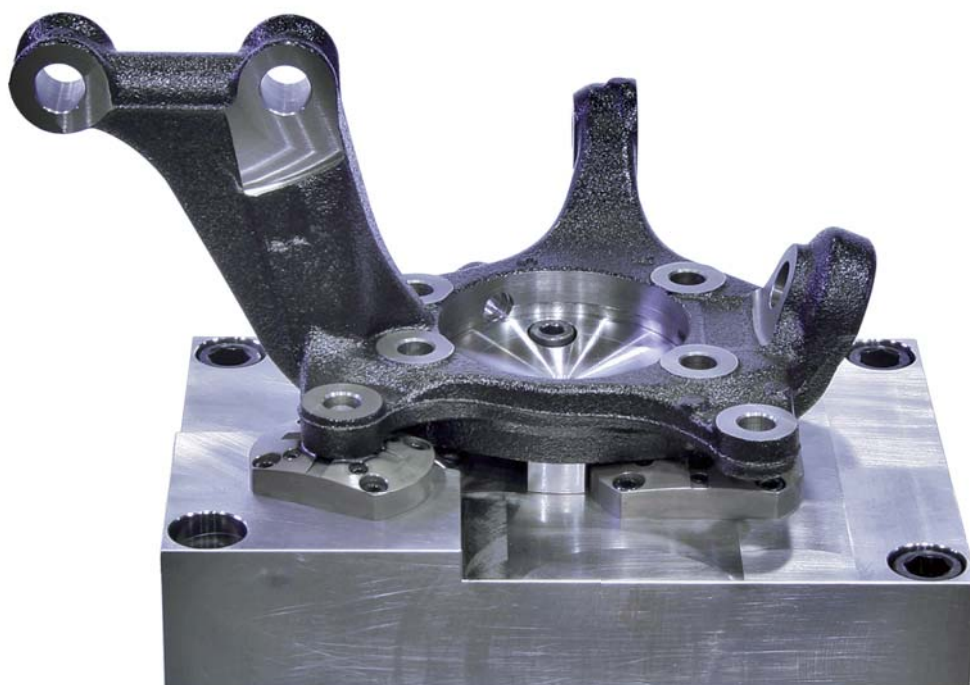

转向节

FCD400 (铸铁)

300×230×130 mm



夹具组合

CGS-N11-06×2个

夹孔内经:ø6

夹紧力:0.9 kN

排气歧管

FC250(铸铁)

300×250×150 mm



立式车床夹具

CGS-N12E09×3个

夹孔内经: $\phi 9$

夹紧力: 3.5 kN



部件加工夹具

CGT-F22-11×3个

夹孔内经:φ11

夹紧力:7.5 kN

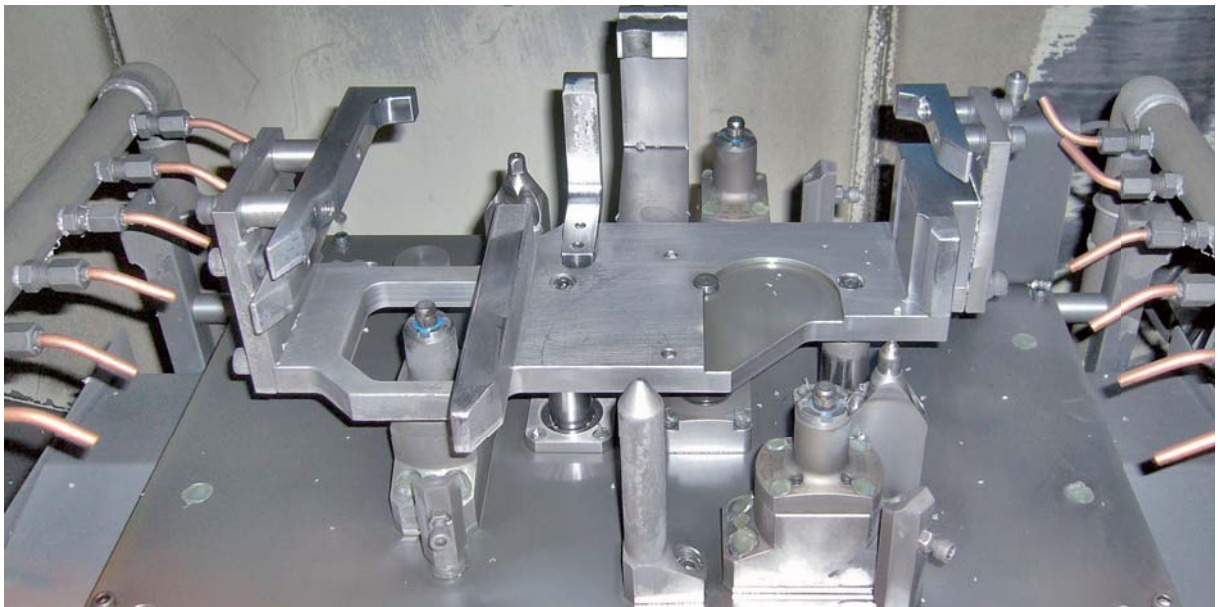

变速箱体加工夹具

CGT-F22-11×3个

夹孔内经:φ11

夹紧力:7.5 kN

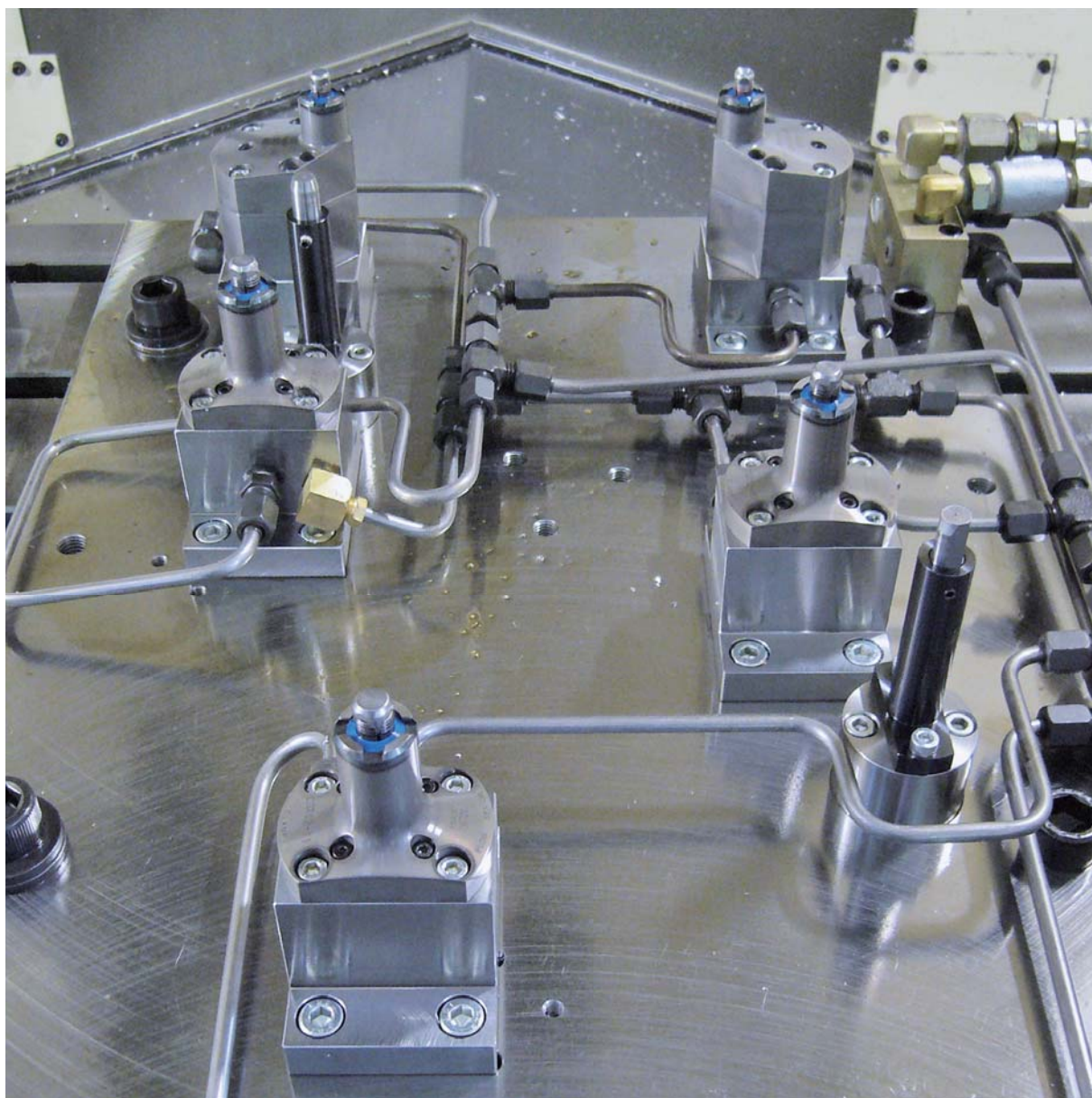

变速箱体加工夹具

CGT-F22-11×3个 CGU-F22-09×2个

夹孔内经:φ11、φ9

夹紧力:6.6 kN



部件加工夹具

CGT-F22E09×2个 CGU-F22E09×1个

夹孔内经: $\phi 9$

夹紧力: 9.8kN



部件加工夹具

CGU-F22-11×2个

夹孔内经: $\phi 10.7$

夹紧力: 5.5kN

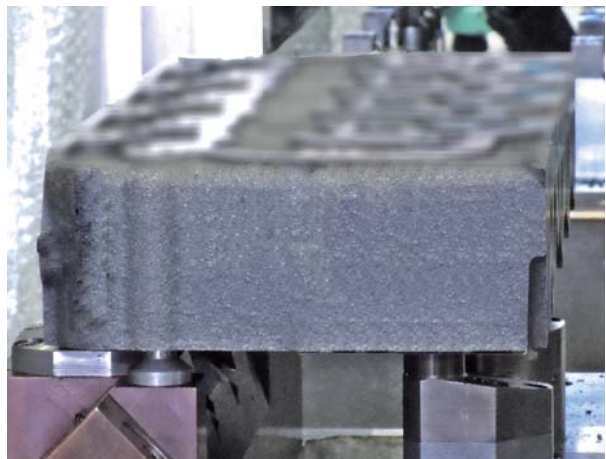
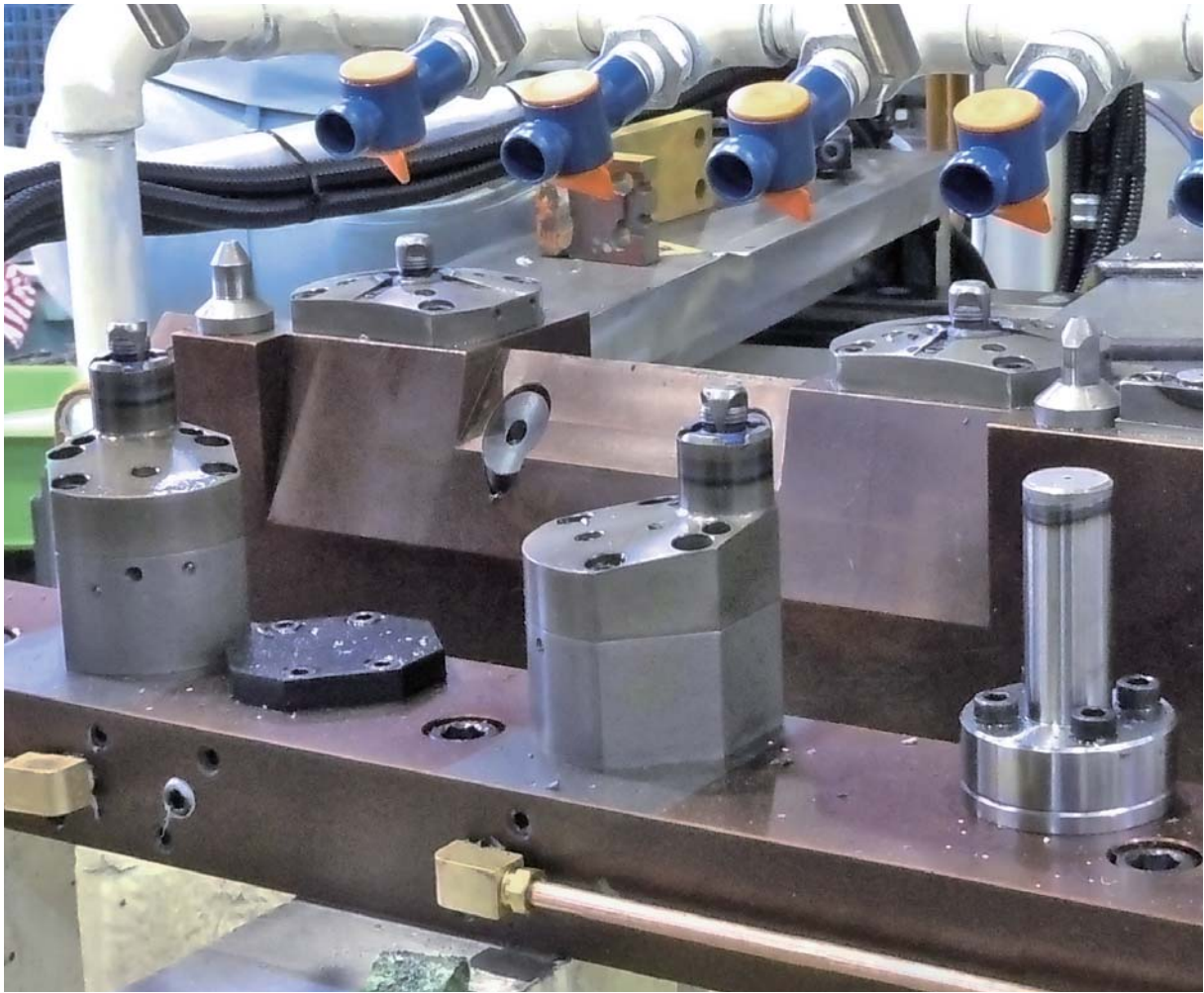

夹具组合

CGU-F22E12×2个 CGS-N23E12×2个

夹孔内经:φ12

夹紧力:13.6 kN

气缸盖

FC250

432 × 183 × 70 mm

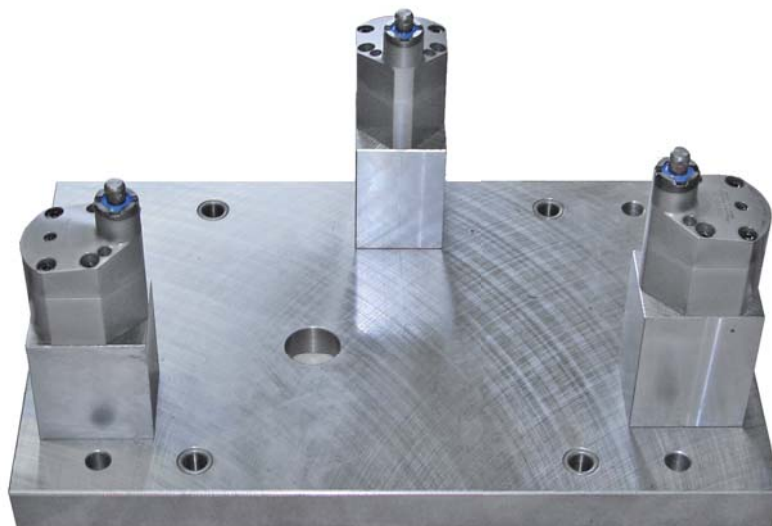

夹具组合

CGU-F22-11×3个

夹孔内经:ø11

夹紧力:3.5 kN



车轴箱

铸铝

210×270×160 mm

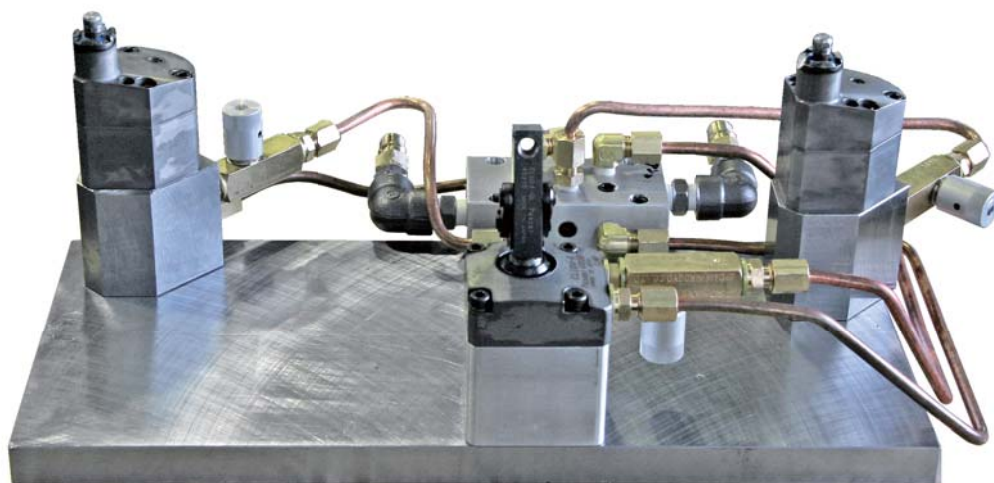

夹具组合

CGU-F22-09×2个 CLU04-R×1个

夹孔内经:φ9

夹紧力:1.6 kN

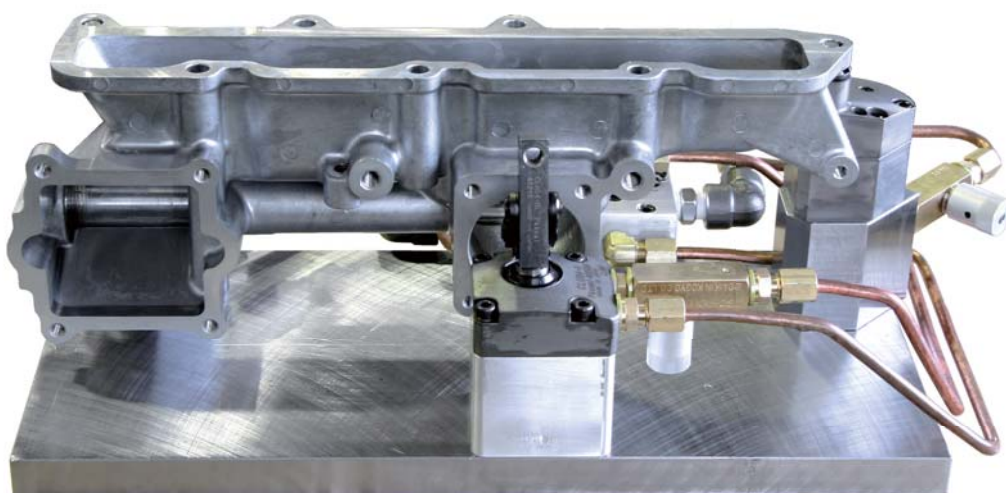

进气歧管

铸铝

370×100×125 mm



加工夹具

CGE-N22E070×2个

夹孔内经:ø7

夹紧力:1.3 kN



压缩机部件

铸铝

ø110×67 mm



加工夹具

CGE-N22E085×1个 CGE-N22E076×1个

夹孔内经: $\varnothing 8.5$ $\varnothing 7.6$

夹紧力: 1.3 kN

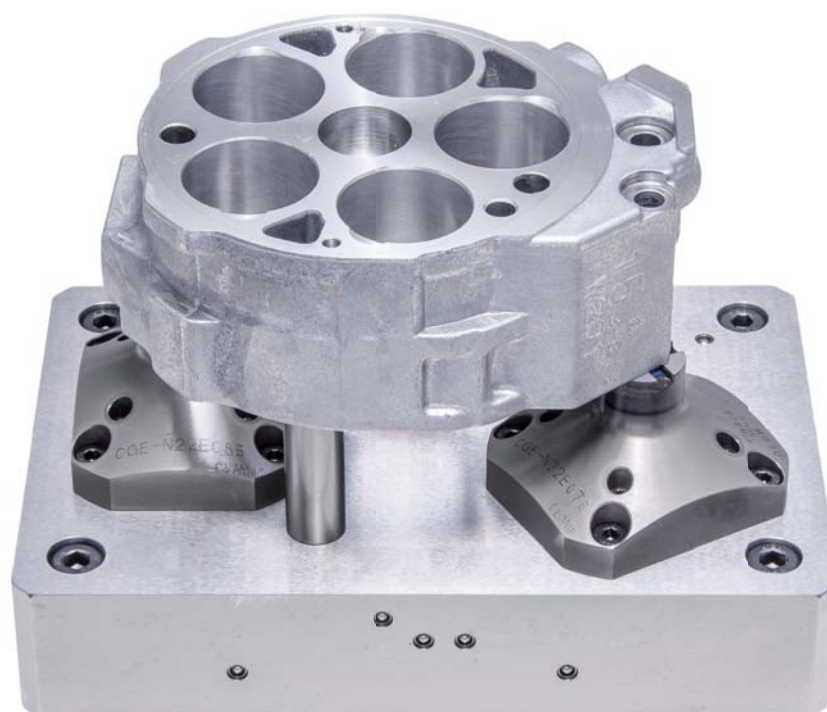

压缩机部件

铸铝

145×120×50 mm

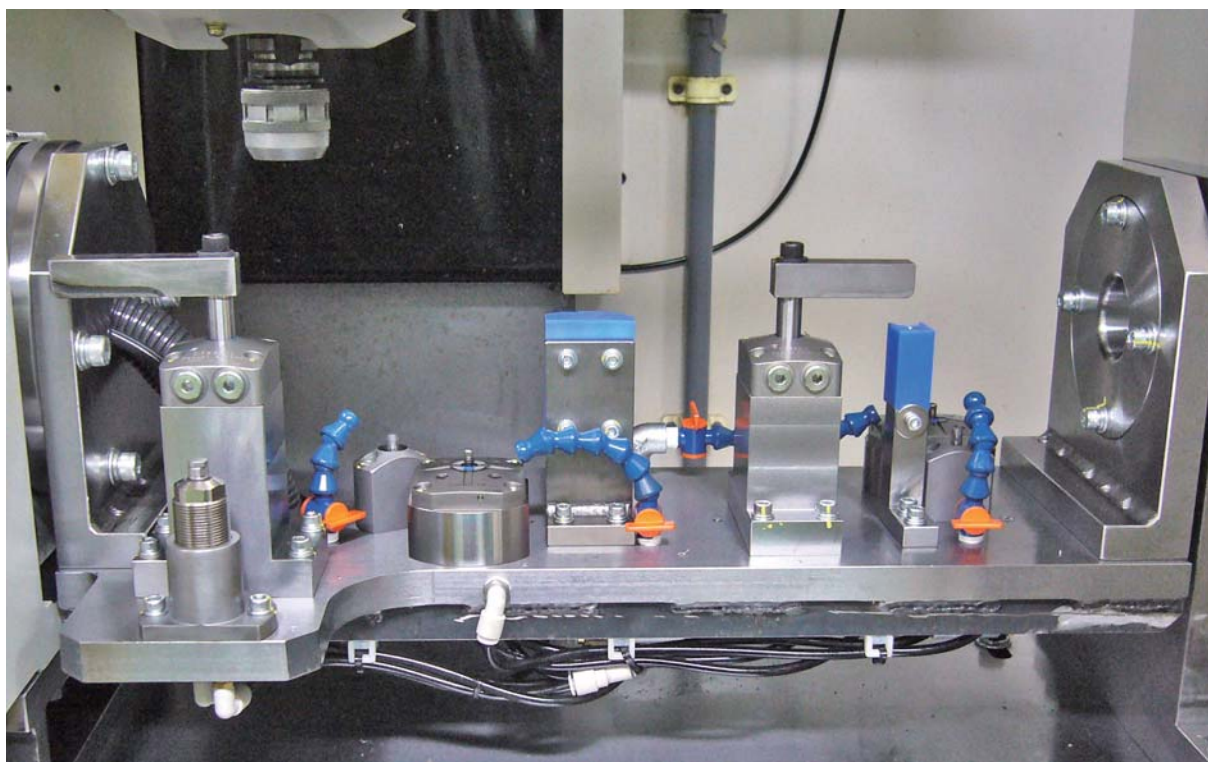

发动机部件加工夹具

CGX-N22-06×2个

夹孔内经:φ6

夹紧力:1.3 kN

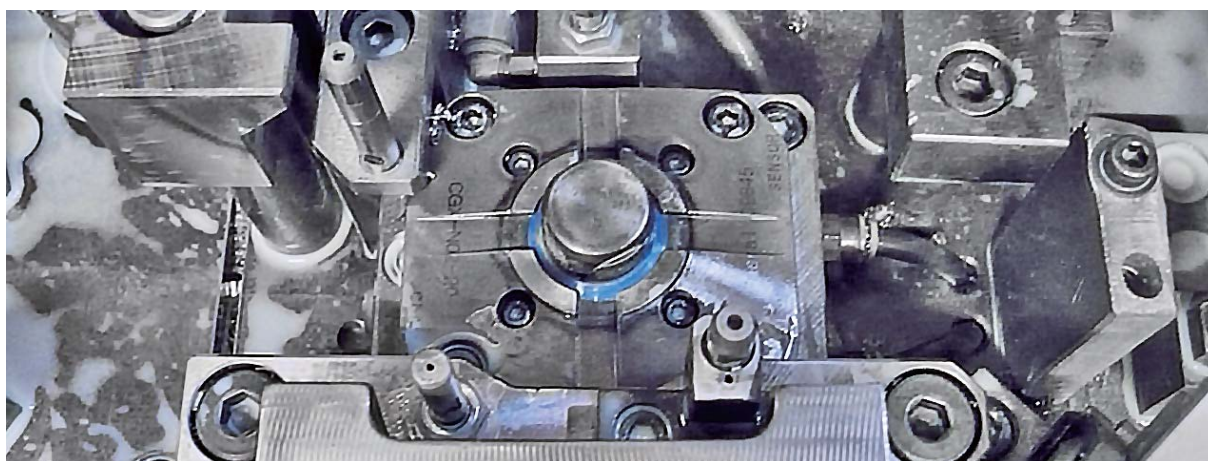

泵盖加工夹具

CGX-N22-20×1个

夹孔内经:φ20

夹紧力:0.5 kN



部件清洗夹具
CGX-N22-11×2个
夹孔内经: $\varnothing 11$
夹紧力: 1.3 kN



部件清洗夹具
CGX-N22-11×2个
夹孔内经: $\varnothing 11$
夹紧力: 1.3 kN

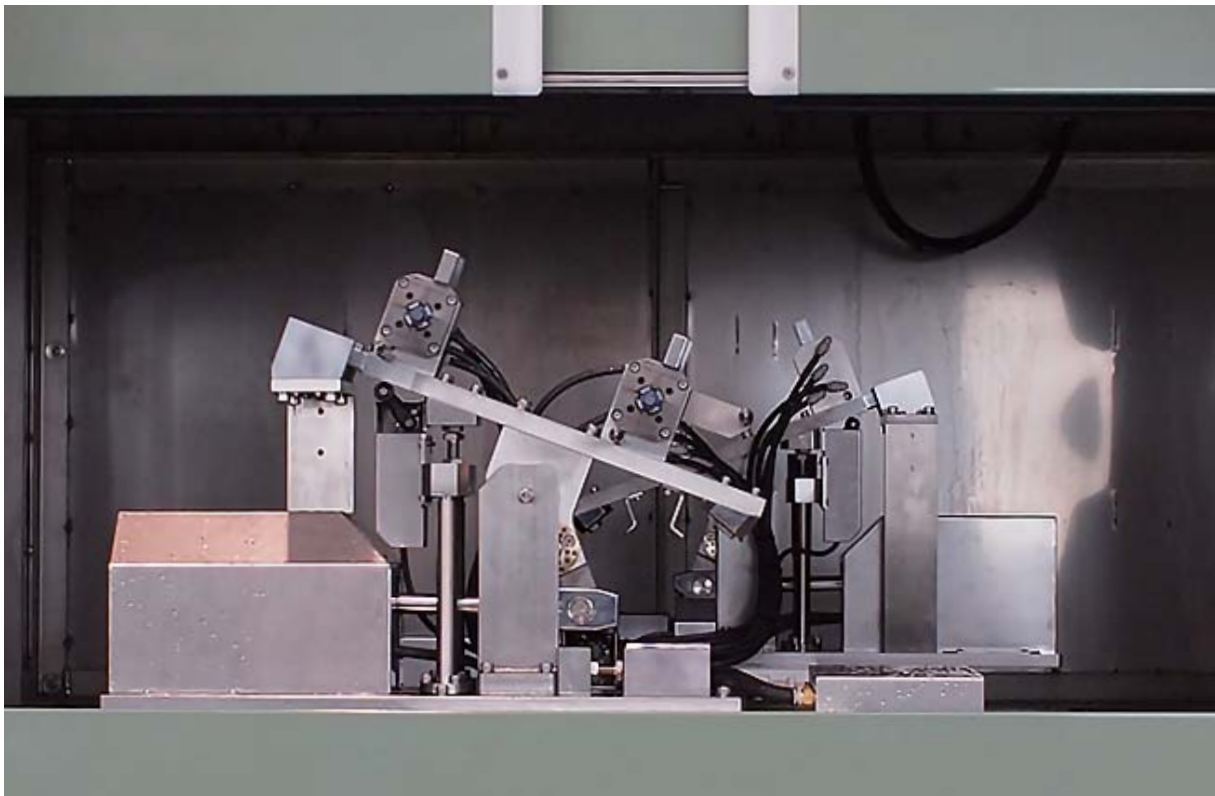

机械手清洗夹具
CGX-N22-12×2个
夹孔内经: $\varnothing 12$
夹紧力: 1.3 kN

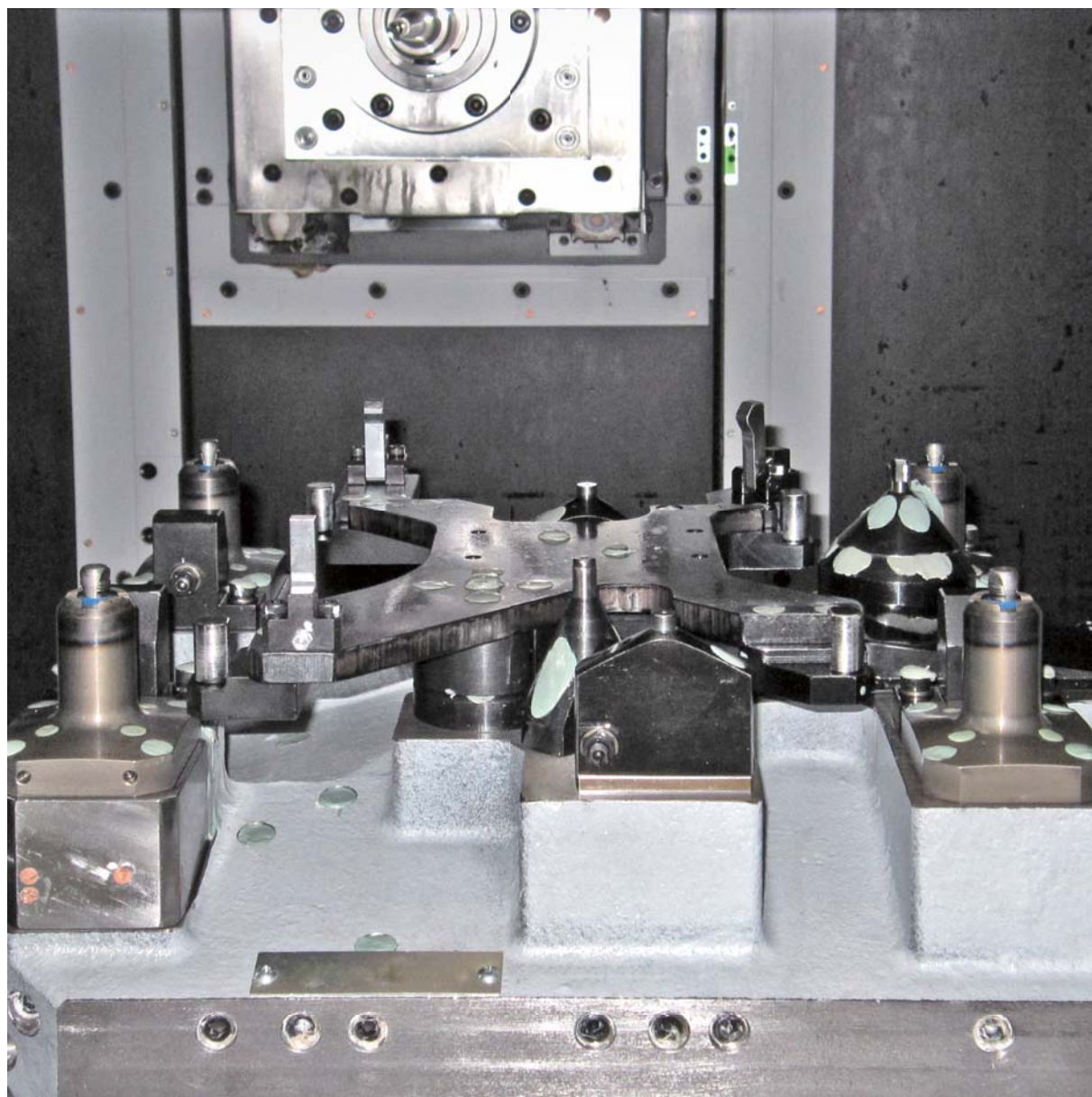

油泵加工夹具

CGY-F22E095×4个

夹孔内经:φ9.5

夹紧力:4 kN

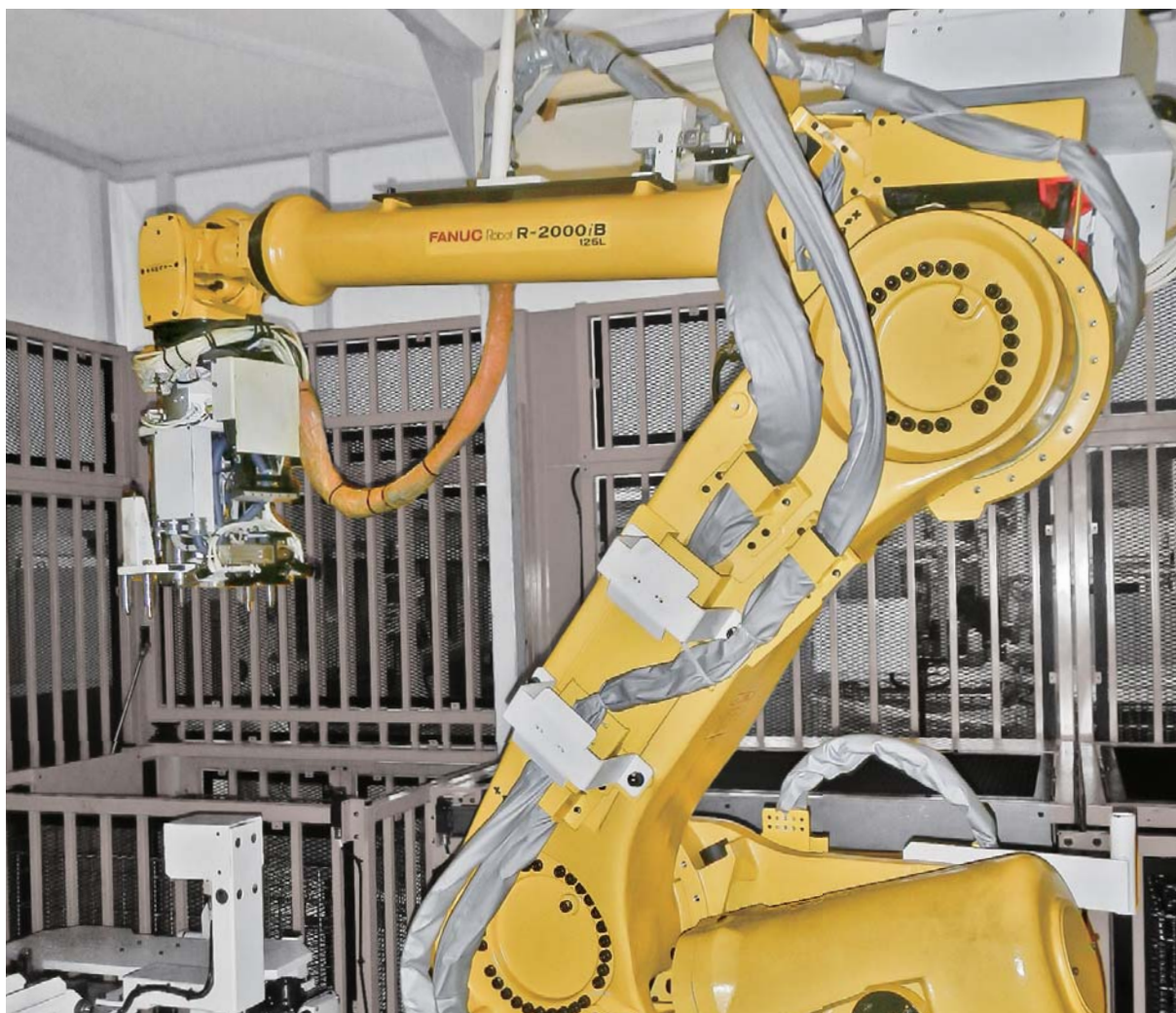

轴承盖座搬运夹具

CGY-F32-11×2个

夹孔内经: $\phi 11$

夹紧力: 1.5 kN



工件搬送夹具

CGY-F32E11×2个

夹孔内经:φ11

夹紧力:1.5 kN

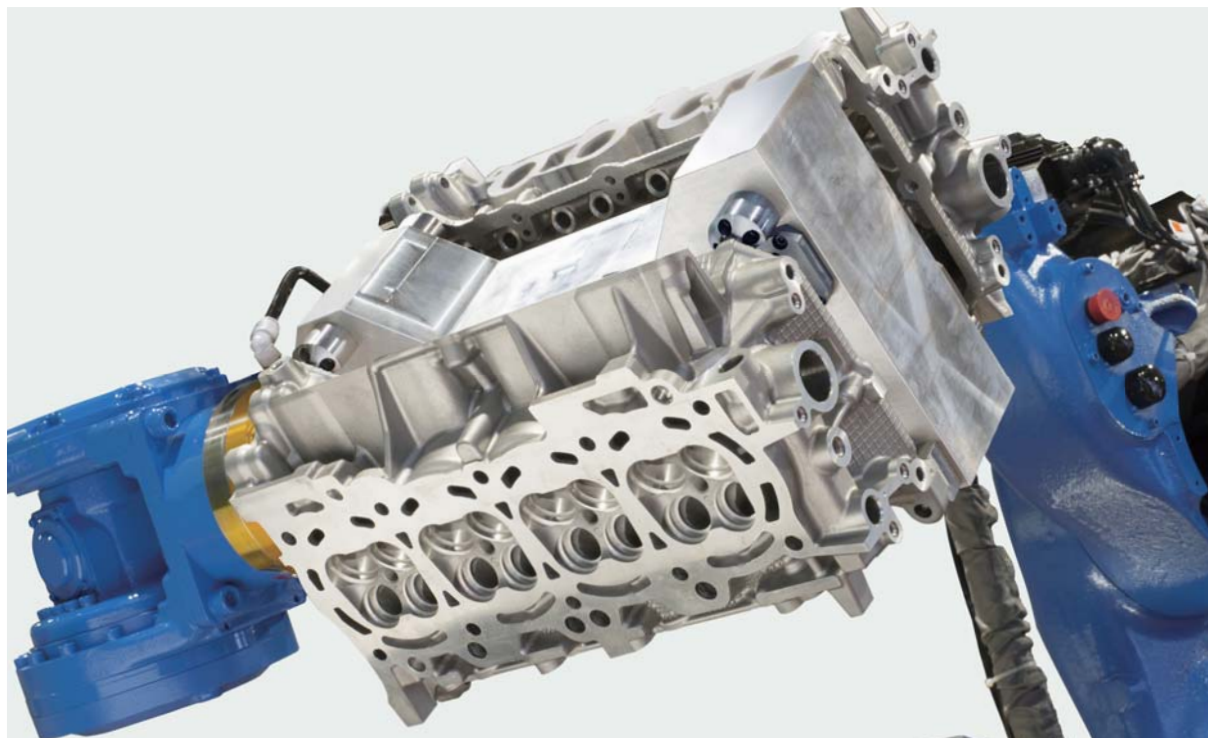

气缸盖搬送夹具

CGY-R32E11×2个

夹孔内经: $\phi 11$

夹紧力: 1.5 kN



气缸盖

铸铝

410×220×120 mm



气缸盖清洗夹具

CGY-F32-12×2个

夹孔内经:φ12

夹紧力:1.5 kN



气缸体清洗夹具

CGY-F32-13×3个

夹孔内经:φ13

夹紧力:2.3 kN



气缸盖

铸铝

410×220×120 mm



清洗夹具

CGY-F42E12×2个

夹孔内经:ø12

夹紧力:1.6 kN

Pascal

大连营业所 帕斯卡(大连)有限公司(Pascal Dalian Corp.)
邮编 116600 辽宁省大连市经济技术开发区双D港二街100-1号1层
电话 0411-8732-2988 传真 0411-8732-7299

上海营业所 帕斯克商贸(上海)有限公司(Pascal Trading Shanghai Corp.)
邮编 201107 上海市闵行区纪翟路1199弄3号1楼
电话 021-5263-4122 传真 021-6296-2882

办事处 ● 长春 ● 天津 ● 武汉 ● 重庆 ● 广州

Pascal corporation Japan

