



Model designation

HUC – 2

Specifications

Model		HUC-2
Number of pumps		1
Discharge pressure	MPa	24.5
Driving air pressure	MPa	0.47
Discharge volume (at no load)	L/min	1.3
Oil tank capacity	L	HIGH-LEVEL : 4.8 / LOW-LEVEL : 1.9
Air consumption rate	Nm ³ /min	Max. 0.4
Weight (without oil)	kg	14

- Fluid used : General mineral based hydraulic oil (ISO-VG32 equivalent)
- Operating temperature : 0 ~ 60°C (No frozen)

Circuit diagram

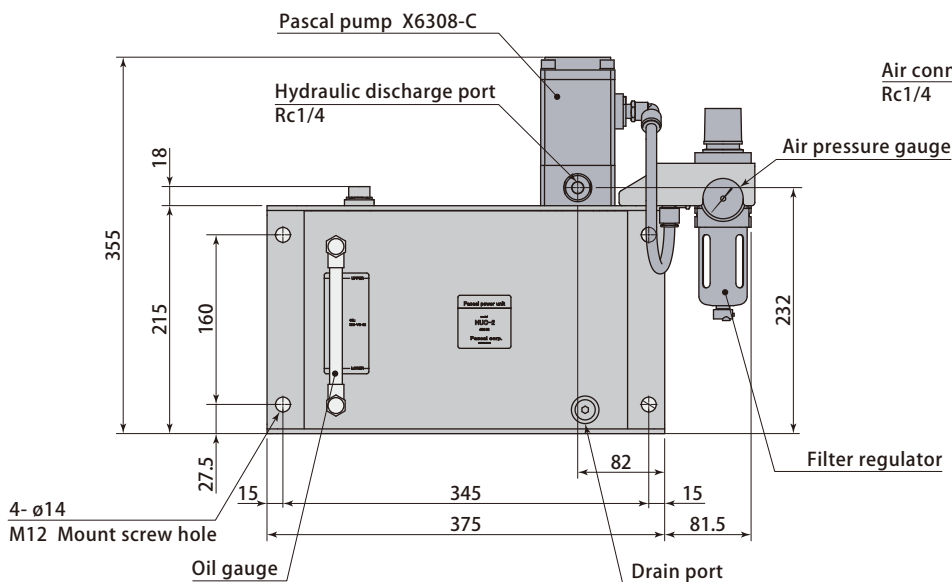
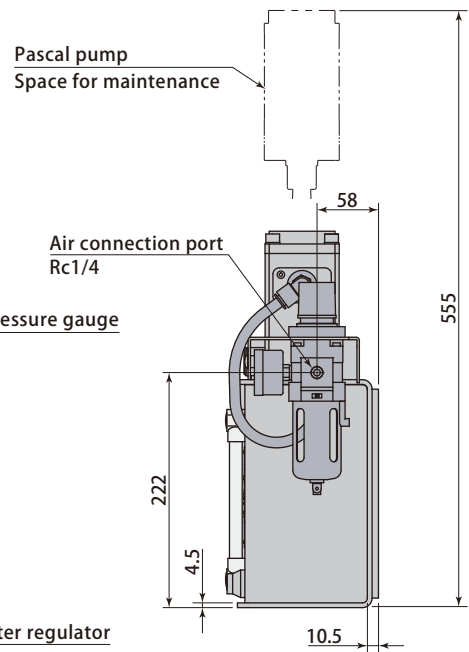
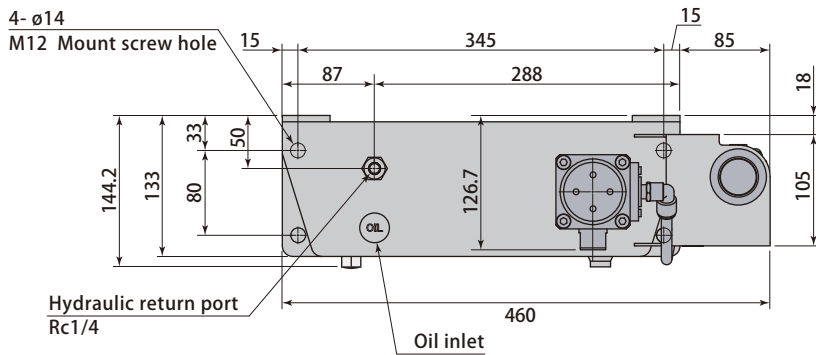
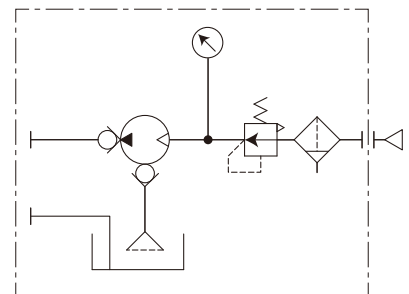

A C Circuit

(**C = A + B Circuit**)

Number of hydraulic circuits		
Upper clamp	Lower clamp	Die-lifter
1	1	1

