

model **DNK**

标准型



model **DNK**4200-50

model **DNR**

短小型



model **DNR**4200-50

model **DNP**

大功率短行程型



model **DNP**4700-25

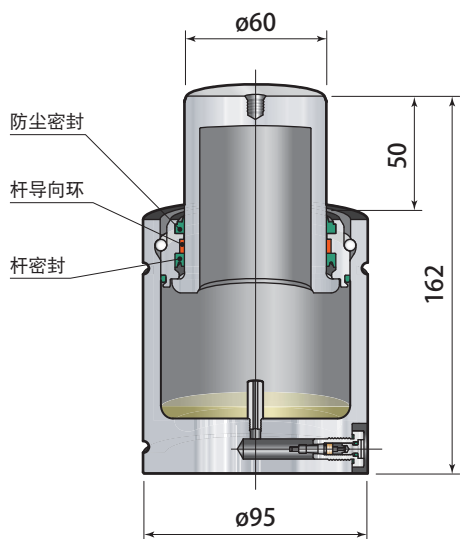

杆密封 杆导向

初始荷重 42.4 kN

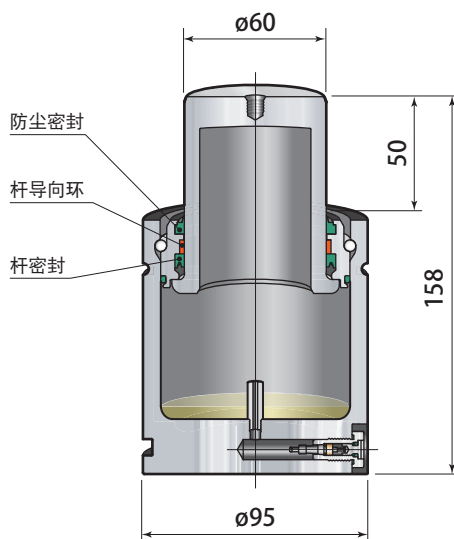

杆密封 杆导向

初始荷重 42.4 kN

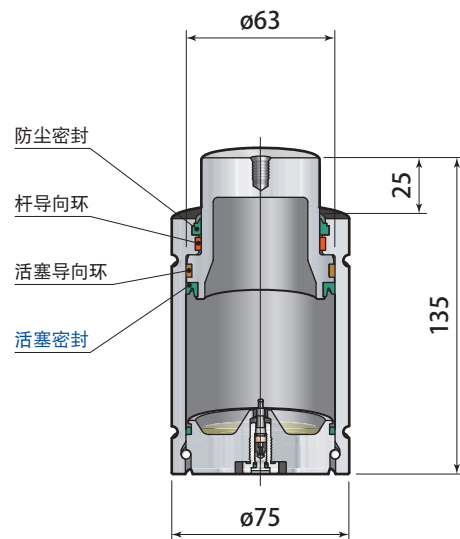

活塞密封 活塞及杆导向

初始荷重 46.8 kN

model **DNK** 与 **DNR** 的不同之处, 请参照 → 11、12 页

model **DNZ**

ISO行程规格



model **DNZ3000-50**

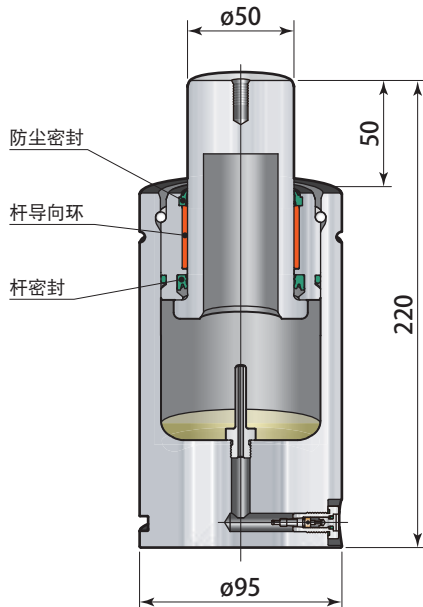

杆密封 杆导向

初始荷重 **29.5 kN**

model **DNA**

长行程型

用于模动盘的归位或顶料板的快速返回



model **DNA3000-200**

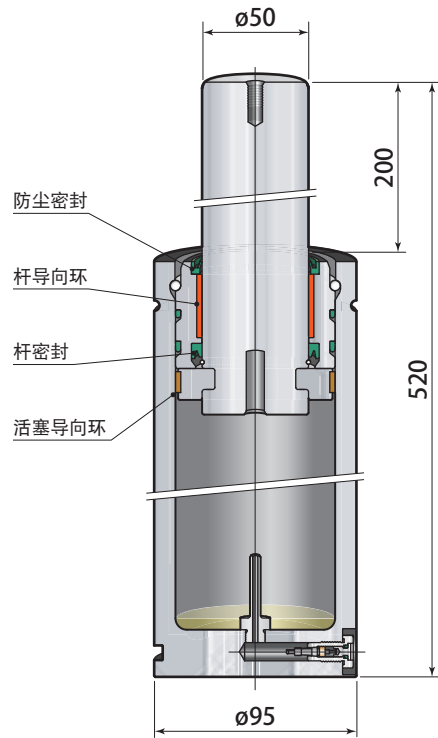

杆密封 活塞及杆导向

初始荷重 **29.5 kN**

氮气弹簧 规格一览

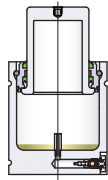
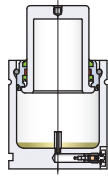
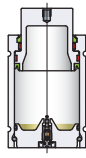
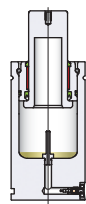
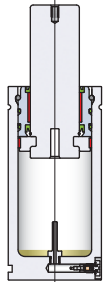
型号、构造	尺寸	气缸直径 mm	初始荷重 kN						
				6	10	12.7	13	16	
model DNK → 13 页 标准型		0350	32	3.62		60		66	72
		0500	38	4.71		60		66	72
		0750	45	7.36				73	79
		1000	50	9.24				78	84
		1500	63	15.3				78	84
		2400	75	23.9					91
		4200	95	42.4					94
		6600	120	66.3					104
		9500	150	95.4					
model DNR → 21 页 短小型		0350	32	3.62		50		56	62
		0500	38	4.71		50		56	62
		0750	45	7.36		52		58	64
		1000	50	9.24				64	70
		1500	63	15.3				70	76
		2400	75	23.9					77
		4200	95	42.4					90
		6600	120	66.3					100
		9500	150	95.4					
model DNP → 31 页 大功率短行程型		0420	25	4.71	56	70			91
		1000	38	10.6	61	78			100
		1800	50	18.8	66	80			106
		4700	75	46.8		80			106
		7500	95	75.4		90			116
		11800	120	117.8		100			126
		18300	150	184.1		110			136
model DNZ → 39 页 ISO 行程规格		0250	38	2.65		70	75.4		82
		0500	45	4.71		105	110.4		117
		0750	50	7.36			120.4		
		1500	75	15.3		130			
		3000	95	29.5		140			
model DNA → 47 页 长行程型		0250	38	2.65					
		0500	45	4.71					
		0750	50	7.36					
		1500	75	15.3					
		3000	95	29.5					
		5000	120	49.8		160			
		7500	150	75.4					
model DNY → 55 页		0170	19	1.71		51			
		0320	25	3.18		51			

氮气弹簧 规格一览

总高 mm														软管接头		
行程 mm														配管接口	页	
19	25	32	38※1	40	50	63※2	75	80	100	125	160	200	250			300
78	90	104	116		140	166	190	200	240	290					M6	→ 85
78	90	104	116		140	166	190	200	240	290						
85	97	111	123		147	173	197	207	247	297					G1/8	→ 72 ~ 80
90	102	116	128		152	178	202	212	252	302						
90	102	116	128		152	178	202	212	252	302						
97	109	123	135		159	185	209	219	259	309						
100	112	126	138		162	188	212	222	262	312						
110	122	136	148		172	198	222	232	272	322						
116	128	142	154		178	204	228	238	278	328						
68	80	94	106		130	156	180	190	230	280					M6	→ 85
68	80	94	106		130	156	180	190	230	280						
70	82	96	108		132	158	182	192	232	282						
76	88	102	114		138	164	188	198	238	288						
82	94	108	120		144	170	194	204	244	294						
83	95	109	121		145	171	195	205	245	295						
96	108	122	134		158	184	208	218	258	308						
106	118	132	144		168	194	218	228	268	318					G1/8	→ 72 ~ 80
116	128	142	154		178	204	228	238	278	328						
	120														-	
	135	167		195	230											
	135	162		190	220											
	135	167		200	240											
	145															
	155															
	165															
	100		126.2		150	177		210	250						G1/8	→ 72 ~ 80
	135		161.2		185	212		245	285	355						
	145		171.2		195	222		255	295	345						
	160		186.2		210	237		270	310	360						
	170		196.2		220	247		280	320	370						
	100				150	177		210	250						G1/8	→ 72 ~ 80
	135				185	212		245			405					
											415	495	595	695		
											430	510				
										370	440	520				
	190		216.2		240	267		300	340	390	460	540	640	740		
	205		231.2		255	282		315	355	405	475	555	655	755		
69	81		107		131	157	186	196	236	286					-	
69	81		107		131	157	186	196	236	286						

※1：model DNZ、DNA 的行程为 38.1

※2：model DNZ、DNA 的行程为 63.5

model DNK 与 model DNR 的不同

model DNK 与 model DNR 氮气弹簧的安装螺丝孔深度不同。

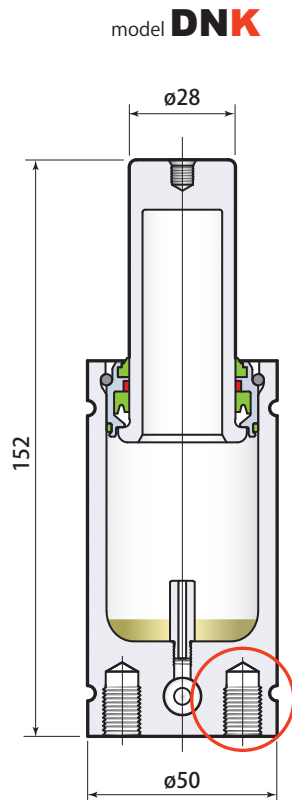

model **DNK**1000-50

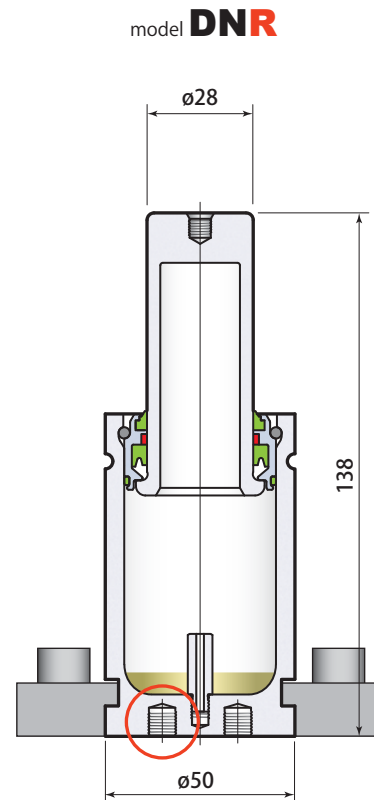

model **DNR**1000-50

底面螺丝孔尺寸

型 号	螺丝尺寸
DNK0350	2-M6 深 11
DNK0500	
DNK0750	2-M8 深 16
DNK1000	2-M10 深 16
DNK1500	2-M8 深 16
	4-M8 深 16
DNK2400	4-M12 深 16
DNK4200	
DNK6600	
DNK9500	

推荐采用的法兰盘固定型

型 号	螺丝尺寸
DNR0350	2-M6 深 6
DNR0500	
DNR0750	2-M8 深 6
DNR1000	
DNR1500	
DNR2400	4-M8 深 6

底面牢固安装型

型 号	螺丝尺寸
DNR4200	4-M8 深 13
DNR6600	4-M10 深 13
DNR9500	4-M10 深 16

model DNK 与 model DNR 的不同

model DNK 与 model DNR 的配管接口尺寸不同。

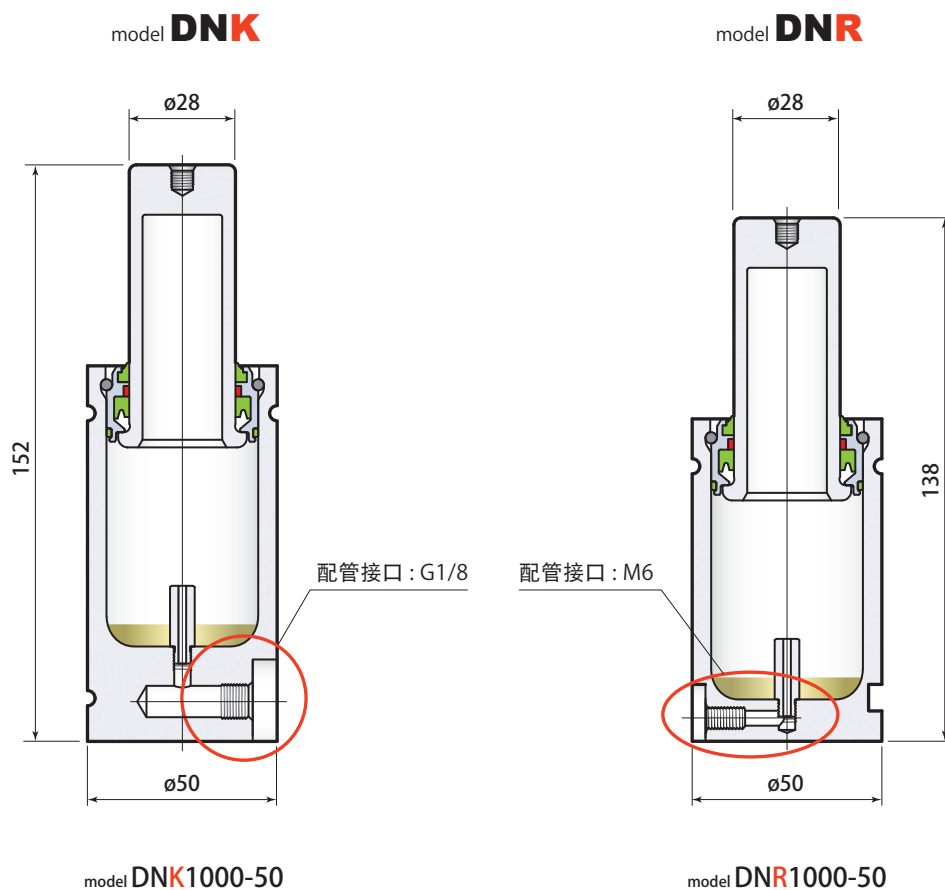

配管接口尺寸

型 号	螺丝尺寸
DNK0350	M6 螺丝
DNK0500	
DNK0750	G 1/8 螺丝
DNK1000	
DNK1500	
DNK2400	
DNK4200	
DNK6600	
DNK9500	

配管接口尺寸

型 号	螺丝尺寸
DNR0350	M6 螺丝
DNR0500	
DNR0750	
DNR1000	
DNR1500	
DNR2400	
DNR4200	G 1/8 螺丝
DNR6600	
DNR9500	

- model DNR2400 以下小型号的气缸底面厚度薄，因此使用接头时须将模具的干涉部分切除。