

air Pallet clamp

Dual cylinder model Double acting 0.5 MPa

model **CPY**

Locate ring
Flange mounting
model **CPS-EF**



Air pallet clamp Dual cylinder model
model **CPY-A**

Dual cylinder model

model CPY-□□H.



Highly rigid pallet clamp and repeatability of 3 μm with dual surface contact
 Compact downsized compared with the conventional model thanks to dual cylinder structure

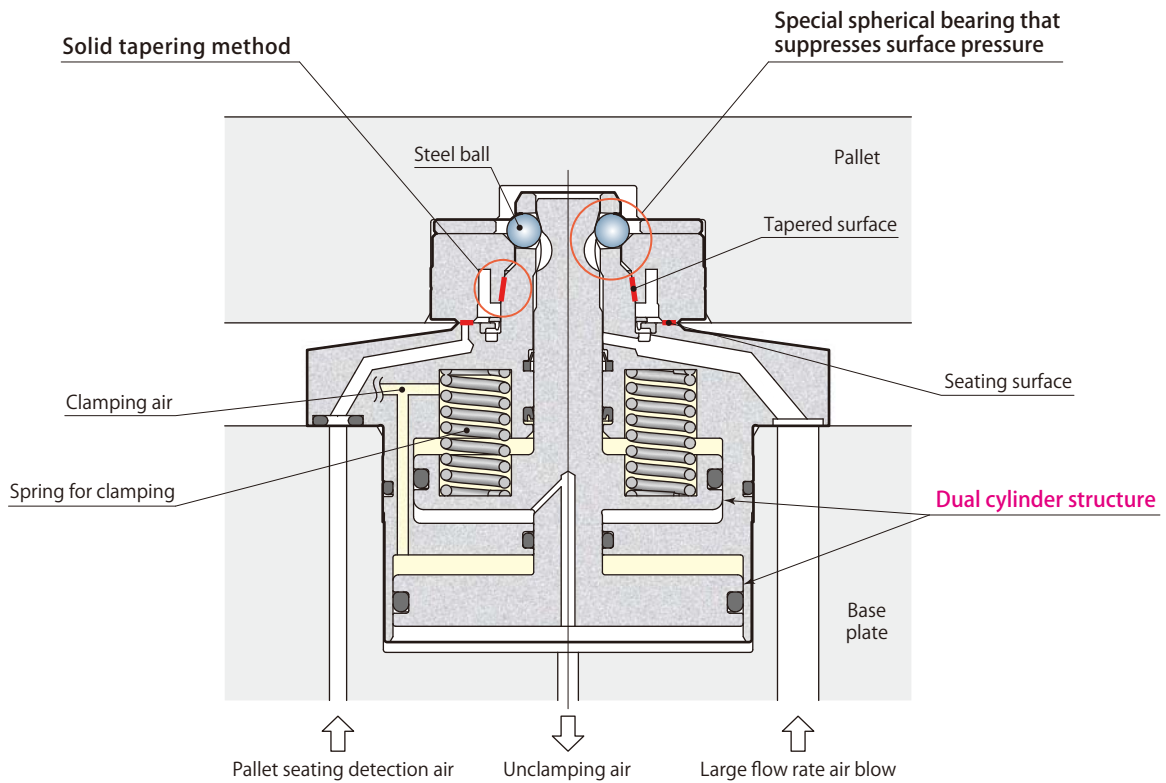

Air pallet clamp
Dual cylinder model

Specifications

	Type	Size	
CPY -	A : Taper cone circle	02	H
	B : Taper cone cut 45°	03	
	C : Taper cone cut 90°	04	
		06	
	S : Shim	10	

■ indicates made to order.

Model			CPY-□02H	CPY-□03H	CPY-□04H	CPY-□06H	CPY-□10H
Air pressure range		MPa	0.4–0.5 (model CPS-L)		0.4–0.5 (model CPS-E)		
			0.25–0.5 (model CPS-D, CPS-F)				
Clamping force*1	Air pressure 0MPa*2	kN	0.1	0.3	0.8	1.2	1.8
	Air pressure 0.25MPa	kN	0.9	1.5	2.4	3.7	5.8
	Air pressure 0.3MPa	kN	1.0	1.8	2.7	4.2	6.6
	Air pressure 0.4MPa	kN	1.3	2.3	3.4	5.2	8.2
	Air pressure 0.5MPa	kN	1.7	2.7	4.0	6.1	9.8
Clamping force calculation (P: Air pressure MPa)*1			$3.10 \times P + 0.1$	$4.88 \times P + 0.3$	$6.38 \times P + 0.8$	$9.88 \times P + 1.2$	$16.0 \times P + 1.8$
Cylinder capacity*1	Clamp	cm ³	7.3	11.6	15.3	23.8	43.7
	Unclamp	cm ³	7.7	11.9	15.6	24.4	44.7
Full stroke		mm	4.4	4.4	4.4	4.4	5.0
Max. allowable eccentricity for pallet setting		mm	±1.0	±1.0	±1.0	±1.5	±2.0
Lift stroke*3		mm	1				
Lift force*1*4	Air pressure 0.25MPa	kN	0.3	0.4	0.2	0.5	0.8
	Air pressure 0.3MPa	kN	0.4	0.6	0.4	0.7	1.3
	Air pressure 0.4MPa	kN	0.6	0.8	0.7	1.3	2.2
	Air pressure 0.5MPa	kN	0.8	1.1	1.1	1.9	3.1
Lift force calculation (P: Unclamping air pressure MPa)*1*4			$1.74 \times P - 0.10$	$2.71 \times P - 0.25$	$3.55 \times P - 0.68$	$5.56 \times P - 0.92$	$8.94 \times P - 1.39$
Max. allowable load (including a pallet)*5	Horizontal mounting	kN	2.0	2.5	3.0	8.0	15.0
	Vertical mounting	kN	0.3	0.4	0.5	1.5	2.5
Mass*1		kg	0.4	0.6	0.8	1.3	2.3
Recommended tightening torque of mounting screws*6 N·m			3.5	3.5	7	7	7

- Proof pressure: 0.75 MPa
- Operating temperature: 0–70 °C
- Fluid used: Air*7
- Oil supply: Not required
- Recommended air blow pressure: 0.3–0.5 MPa

- *1: The figure indicates one piece of clamp.
- *2: The value indicates the force generated by the spring.
- *3: This is the amount for lifting pallet when unclamping.
- *4: Set the air pressure for unclamping so that the lift force is equal to or greater than the max. allowable load.
The max. allowable load can be calculated by the formula of lift force × quantity of CPY × 0.8.
- *5: This is maximum allowable load of pallet, regardless of how many clamps are used.
- *6: ISO R898 class 12.9
- *7: Supply the dry and filtered air. Particulate size 5 μm or less is recommended.

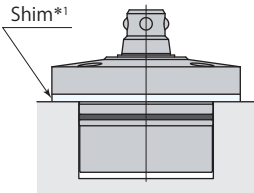
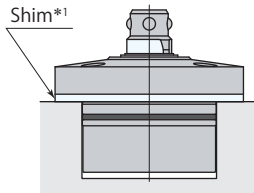
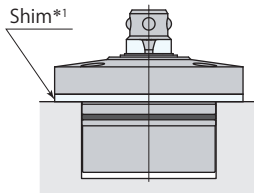
Pallet clamp type	A Taper cone circle	B *2 Taper cone cut 45°	C *2 Taper cone cut 90°
Air clamp model CPY	 model CPY-A□H	 model CPY-B□H	 model CPY-C□H

- *1: Shim of pallet clamp can be used when heights of mounted clamps vary. (option)
- *2: Taper cone cut can be selected from B type or C type.

Dimensions

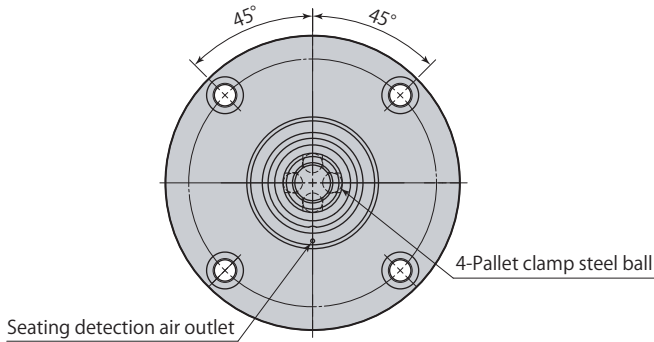

CPY-A02-04H

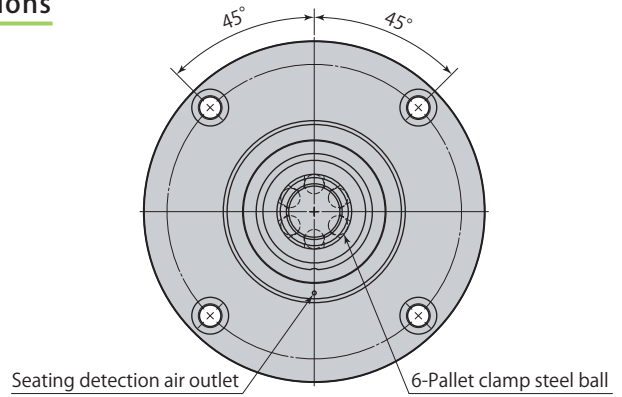

CPY-A06/10H

Positioning direction
CPY-B□H: 45°
CPY-C□H: 90°

Positioning pin
mounting position
(CPY-B□H, CPY-C□H only)

P.C.D. S
(mounting hole &
positioning pin hole)

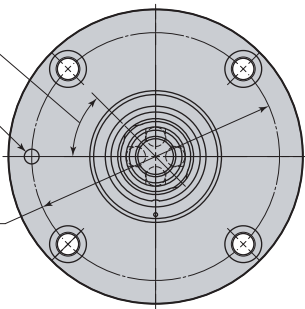

CPY-^B/_C 02-04H

Positioning direction
CPY-B□H: 45°
CPY-C□H: 90°

Positioning pin
mounting position
(CPY-B□H, CPY-C□H only)

P.C.D. S
(mounting hole &
positioning pin hole)

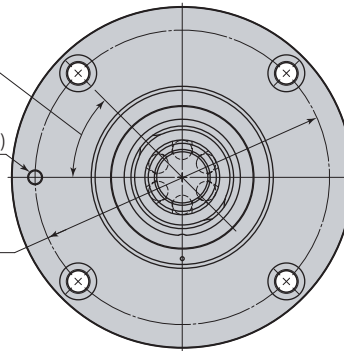

CPY-^B/_C 06/10H

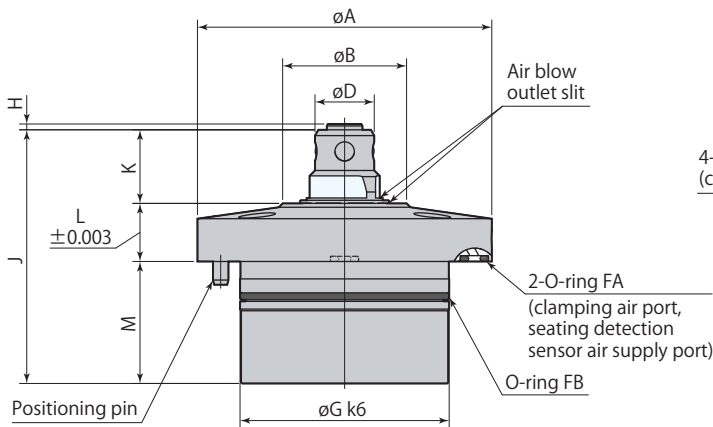

Unclamp

4-U Thread through
(clamp removal tap)

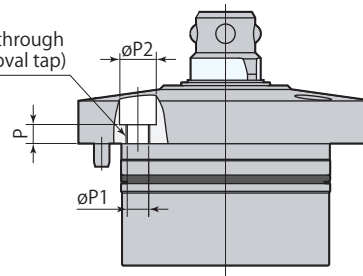

Stroke end

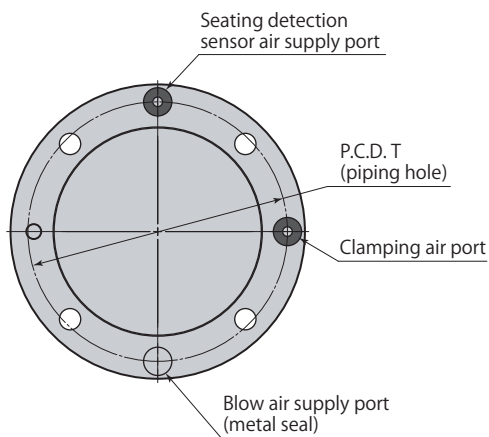

CPY-□ 02-04H

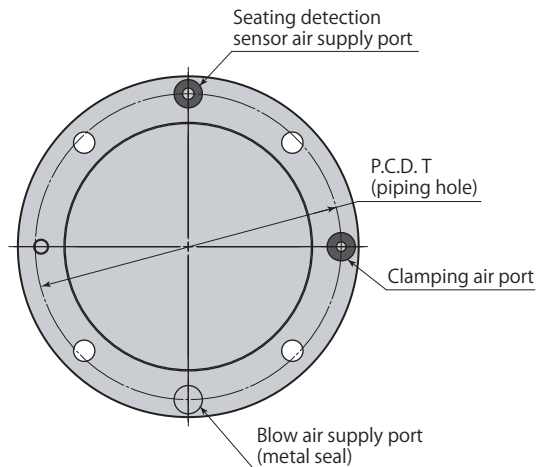

CPY-□ 06/10H

Model	CPY-□02H	CPY-□03H	CPY-□04H	CPY-□06H	CPY-□10H
øA	59	68	76	88	106
øB	32	32	32	45	48
øD	15.3	15.3	15.3	19.3	23
øG	39 ^{+0.018} _{+0.002}	48 ^{+0.018} _{+0.002}	54 ^{+0.021} _{+0.002}	66 ^{+0.021} _{+0.002}	84 ^{+0.025} _{+0.003}
H	1.5	1.5	1.5	1.5	1.3
J	61.5	61.5	65.5	72	83.5
K	19	19	19	22.5	26
L	12	12	15	18	22
M	30.5	30.5	31.5	31.5	35.5
P	4	3.5	5	8	11
øP1	4.3	4.3	5.5	5.5	5.5
øP2	8	8	9.5	9.5	9.5
S	49	58	64	76	94
T	50	59	67	79	96
U	M5×0.8	M5×0.8	M6×1	M6×1	M6×1
O-ring FA (fluorocarbon hardness Hs90)	P4	P4	P4	P4	P5
O-ring FB (fluorocarbon hardness Hs90)	AS568-028	AS568-031	AS568-033	AS568-036	AS568-151

- Be sure to match up phase of pallet clamp steel balls and locate ring steel ball grooves.
- Positioning direction is the direction in which tapered surface has not been cut.
- Use øA, which has been ground at the same time as tapered surface, for positioning measurement after mounting.
- Mounting screws are not included.
- Pal coupler (**pages →80-85**) recommended when using couplers in a set.
- Blow air supply port is metal seal. Air bubbles may come out from the mounting surface due to the air blow, however it is not abnormal.

Mounting details

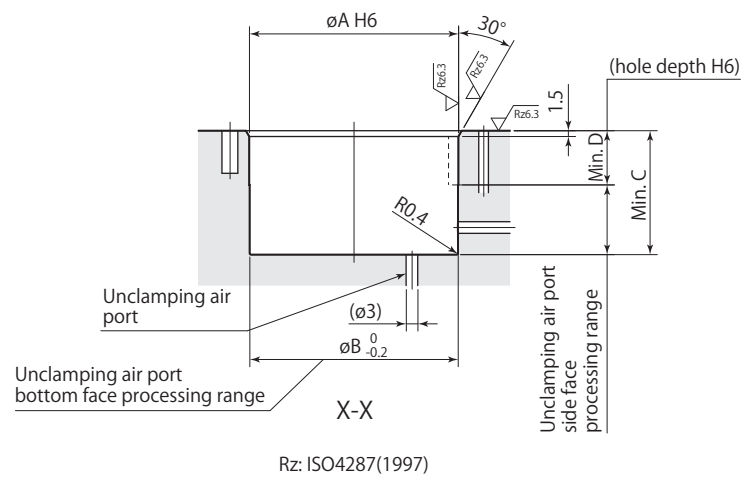
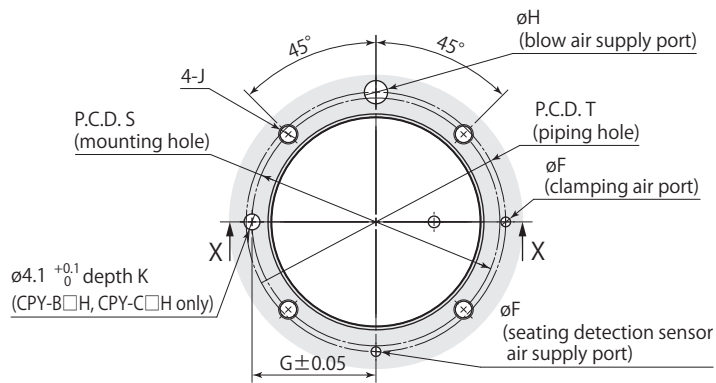

Shim (option)

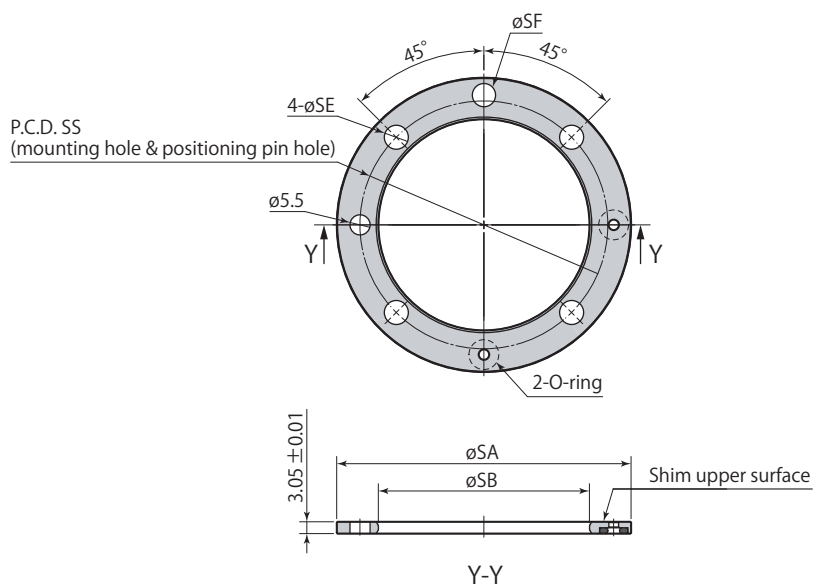

Air pallet clamp

CPY Dual cylinder model

mm

Model	CPY-□02H	CPY-□03H	CPY-□04H	CPY-□06H	CPY-□10H
øA	39 ^{+0.016} ₀	48 ^{+0.016} ₀	54 ^{+0.019} ₀	66 ^{+0.019} ₀	84 ^{+0.022} ₀
øB	39	48	54	66	84
øF	2.5	2.5	2.5	2.5	3
G	24.5	29	32	38	47
øH	4.5-6	4.5-6	4.5-6	4.5-6	5.5-7
J	M4	M4	M5	M5	M5
S	49	58	64	76	94
T	50	59	67	79	96

Not using shim (standard specifications)

C	31	31	32	32	36
D	14	14	14	14	15
K	7	7	7	7	7

Using shim (shim specifications)

C	28	28	29	29	33
D	11	11	11	11	12
K	4	4	4	4	4

- Process with shim specification dimensions when shim is attached.
- Process either bottom or side surface of unclamping air port.
- Be sure to match up phase of pallet clamp steel balls and locate ring steel ball grooves.

mm

Shim	CPY-S02H	CPY-S03H	CPY-S04H	CPY-S06H	CPY-S10H
øSA	59	68	76	88	106
øSB	39.5	48.5	54.5	66.5	84.5
øSE	5.5	5.5	6.5	6.5	6.5
øSF	6	6	6	6	7
SS	49	58	64	76	94
O-ring (fluorocarbon hardness Hs90)	P4	P4	P4	P4	P5
Mass	0.03kg	0.04kg	0.05kg	0.06kg	0.07kg

- This diagram indicates dimensions at shipping.
- Adjust thickness of shim by grinding to ensure flatness of pallet.
- Grind shim upper surface (surface without O-ring) to adjust shim.

Specifications

Type	Size	Mounting method
D : Repeatability 10 μ m	03 06 10	T : Pallet upper surface mounting
E : Repeatability 3 μ m		D : Pallet lower surface mounting
L : Repeatability 3 μ m* ¹		F : Flange mounting
F : Seating surface positioning (Z axis positioning)		
S : Shim		
P : Protective plate* ²		

■ indicates made to order.

*1: model CPS-L (repeatability 3 μ m) is available for size 03 only. (Exclusive use for CPY-□02H, CPY-□03H)

*2: The protective plate is only flange mounting type.

Locate ring	D * ¹ Repeatability 10 μ m	E or L * ¹ Repeatability 3 μ m	F * ² Seating surface positioning (Z axis positioning)
T Pallet upper surface mounting	model CPS-D□T 	model CPS-E□T 	model CPS-F□T
D Pallet lower surface mounting	model CPS-D□D 	model CPS-E□D 	model CPS-F□D
F Flange mounting	model CPS-D□F 	model CPS-E□F 	model CPS-F□F

*1: model CPS-D (repeatability 10 μ m) cannot be used together with model CPS-E or CPS-L (repeatability 3 μ m).

*2: model CPS-F (seating surface positioning) needs the positioning of XY axes.

*3: It is recommended to use a shim (option) to adjust mounting hole depth for the locate rings for pallet upper surface mounting and lower surface mounting. Grind shim to adjust thickness.

*4: Protective plate (flange mounting only) can be used to prevent damage of seating surface, when pallet must be placed on the floor, etc. (option)

*5: Shim of locate ring of flange mounting can be used when heights of mounted locate rings vary. (option)

Locate ring model correspondence

Pallet clamp		CPY-□02H	CPY-□03H	CPY-□04H	CPY-□06H	CPY-□10H
Repeatability	3 μ m	CPS-L03□		CPS-E03□	CPS-E06□	CPS-E10□
	10 μ m	CPS-D03□			CPS-D06□	CPS-D10□
Seating surface positioning (Z axis positioning)		CPS-F03□			CPS-F06□	CPS-F10□

Mass

kg

Locate ring		D Repeatability 10 μm			E or L Repeatability 3 μm				F Seating surface positioning (Z axis positioning)		
T Pallet upper surface mounting	Model	CPS-D03T	CPS-D06T	CPS-D10T	CPS-L03T	CPS-E03T	CPS-E06T	CPS-E10T	CPS-F03T	CPS-F06T	CPS-F10T
	Mass	0.1	0.2	0.3	0.1	0.1	0.2	0.3	0.1	0.2	0.3
D Pallet lower surface mounting	Model	CPS-D03D	CPS-D06D	CPS-D10D	CPS-L03D	CPS-E03D	CPS-E06D	CPS-E10D	CPS-F03D	CPS-F06D	CPS-F10D
	Mass	0.2	0.3	0.5	0.2	0.2	0.3	0.5	0.2	0.3	0.5
F Flange mounting	Model	CPS-D03F	CPS-D06F	CPS-D10F	CPS-L03F	CPS-E03F	CPS-E06F	CPS-E10F	CPS-F03F	CPS-F06F	CPS-F10F
	Mass	0.1	0.2	0.3	0.1	0.1	0.2	0.3	0.1	0.2	0.4

Height of pallet from base plate

Locate ring mounting method	Pallet changing	Pallet setting (Unclamp)	Clamp
T Pallet upper surface mounting			
D Pallet lower surface mounting			
F Flange mounting			

mm

Pallet clamp		CPY-□02H	CPY-□03H	CPY-□04H	CPY-□06H	CPY-□10H
T Pallet upper surface mounting	A	Min. 33	Min. 33	Min. 36	Min. 43	Min. 51
	B	12.5	12.5	15.5	18.5	22.5
D Pallet lower surface mounting	C	11.5	11.5	14.5	17.5	21.5
	D	Min. 43	Min. 43	Min. 46	Min. 53	Min. 63
F Flange mounting	E	22	22	25	28.5	34.5
	F	21	21	24	27.5	33.5

- Pallet lift capacity for dimension A or D or more is needed to change pallet.
- The height from base plate to pallet varies when using shim for pallet clamp or locate ring (flange mounting).

Dimensions

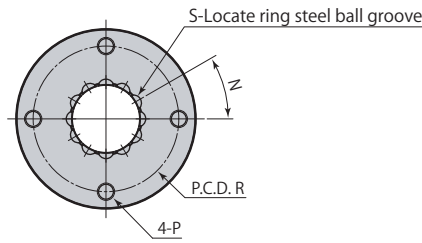

CPS-D03-10T Locate ring (D type)

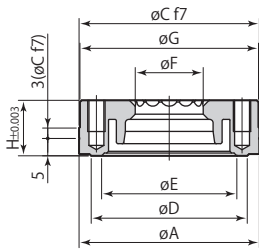

CPS-E03-10T Locate ring (E type)
CPS-L03T Locate ring (L type)

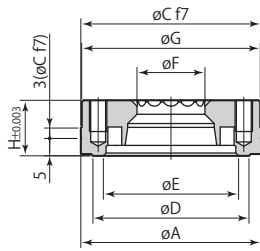

CPS-F03-10T Locate ring (F type)

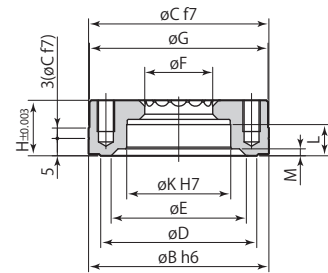

mm

Model	CPS-□03T	CPS-□06T	CPS-□10T
∅A	40 ^{+0.005} _{-0.011}	52 ^{+0.006} _{-0.013}	60 ^{+0.006} _{-0.013}
∅B	40 ⁰ _{-0.016}	52 ⁰ _{-0.019}	60 ⁰ _{-0.019}
∅C	40 ^{-0.025} _{-0.050}	52 ^{-0.030} _{-0.060}	60 ^{-0.030} _{-0.060}
∅D	32	45	48
∅E	28	39	42
∅F	15.6	19.6	23.3
∅G	39.5	51.5	59.5
H	13	16	20
∅K	22 ^{+0.021} ₀	30 ^{+0.021} ₀	32 ^{+0.025} ₀
L	7	9	11
M	2	2.5	2.5
N*	45°	30°	30°
P	M5×0.8 depth 6	M5×0.8 depth 9	M6×1 depth 11
R	31	42	48
S	8	12	12

* : Be sure to match up phase of locate ring steel ball grooves and pallet clamp steel balls.

● Mounting screws are not included.

Shim (option)

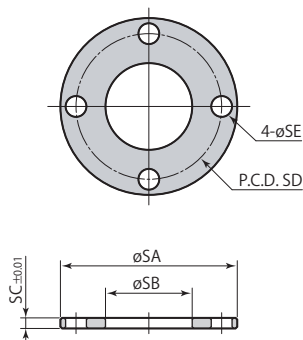

mm

Shim	CPS-S03T	CPS-S06T	CPS-S10T
∅SA	39	51	59
∅SB	21	25	33
SC	2.05	3.05	3.05
SD	31	42	48
∅SE	6	6	7
Mass	0.01 kg	0.03 kg	0.04 kg

● This diagram indicates dimensions at shipping.

● Adjust thickness of shim by grinding to ensure flatness of pallet.

Mounting details

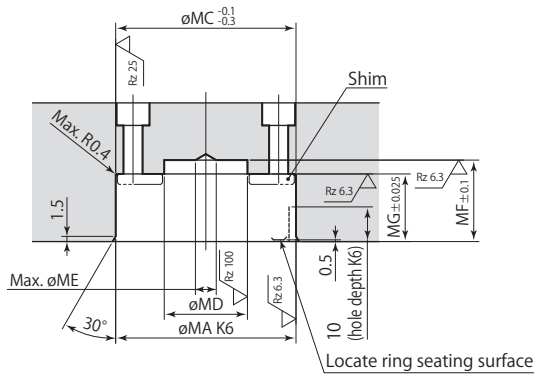
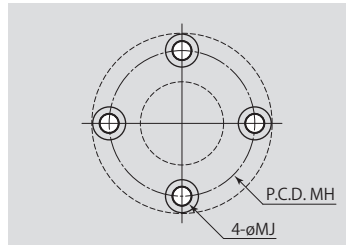

CPS-D03-10T, CPS-E03-10T, CPS-L03T

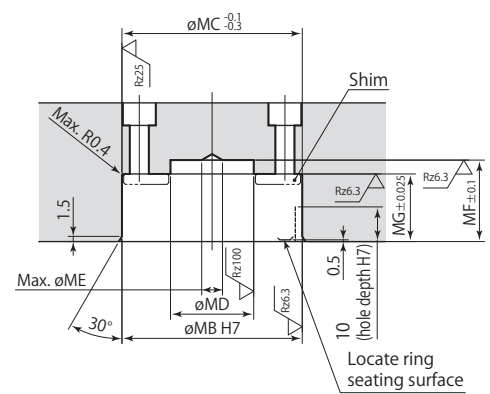

CPS-F03-10T

Rz: ISO4287(1997)

Model	CPS-□03T	CPS-□06T	CPS-□10T
øMA	40 ^{+0.003} _{-0.013}	52 ^{+0.004} _{-0.015}	60 ^{+0.004} _{-0.015}
øMB	40 ^{+0.025} ₀	52 ^{+0.030} ₀	60 ^{+0.030} ₀
øMC	40	52	60
øMD	20	24	28
øME	6	6	8
MF	20	23.5	26.8
MG	15.5	19.5	23.5
MH	31	42	48
øMJ	5.5	5.5	6.6

● Be sure to match up phase of locate ring steel ball grooves and pallet clamp steel balls.

Dimensions

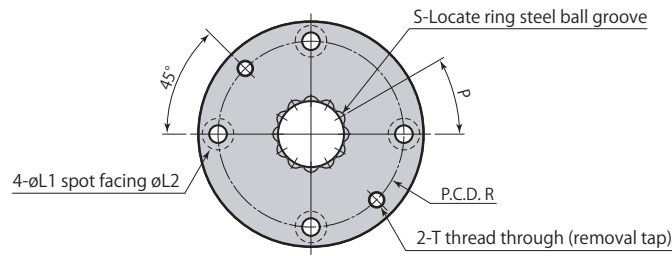

CPS-D03-10D Locate ring (D type)

CPS-E03-10D Locate ring (E type)
CPS-L03D Locate ring (L type)

CPS-F03-10D Locate ring (F type)

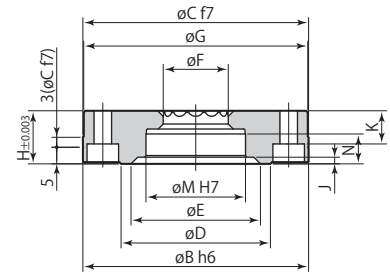
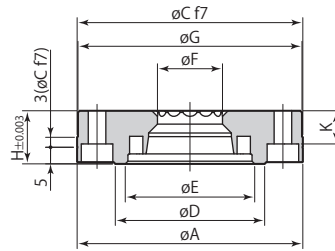
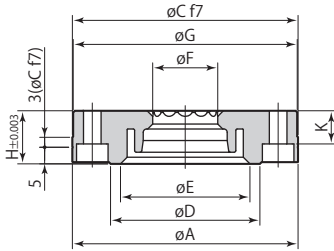

mm

Model	CPS-□03D	CPS-□06D	CPS-□10D
øA	55 ^{+0.006} _{-0.013}	68 ^{+0.006} _{-0.013}	75 ^{+0.006} _{-0.013}
øB	55 ⁰ _{-0.019}	68 ⁰ _{-0.019}	75 ⁰ _{-0.019}
øC	55 ^{-0.030} _{-0.060}	68 ^{-0.030} _{-0.060}	75 ^{-0.030} _{-0.060}
øD	32	45	48
øE	28	39	42
øF	15.6	19.6	23.3
øG	54.5	67.5	74.5
H	13	16	20
J	2	2.5	2.5
K	7	10	13
øL1	5.3	5.3	6.8
øL2	9.5	9.5	11
øM	22 ^{+0.021} ₀	30 ^{+0.021} ₀	32 ^{+0.025} ₀
N	7	9	11
P*	45°	30°	30°
R	43	56	61
S	8	12	12
T	M5×0.8	M5×0.8	M6×1

* : Be sure to match up phase of locate ring steel ball grooves and pallet clamp steel balls.

● Mounting screws are not included.

Shim (option)

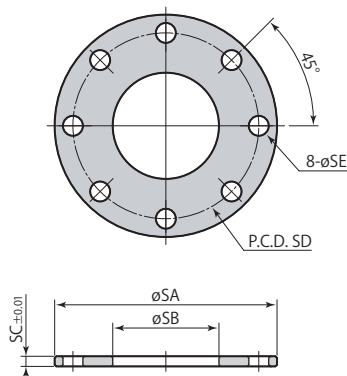

mm

Shim	CPS-S03D	CPS-S06D	CPS-S10D
øSA	54	67	74
øSB	24	32	39
SC	2.05	3.05	3.05
SD	43	56	61
øSE	6	6	7
Mass	0.06 kg	0.06 kg	0.07 kg

● This diagram indicates dimensions at shipping.

● Adjust thickness of shim by grinding to ensure flatness of pallet.

Dimensions

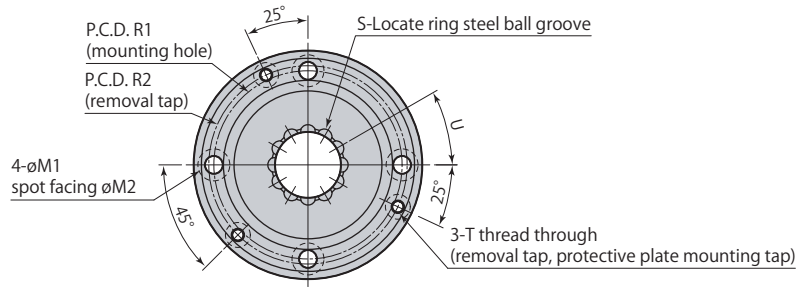

CPS-D03-10F Locate ring (D type)

CPS-E03-10F Locate ring (E type)
CPS-L03F Locate ring (L type)

CPS-F03-10F Locate ring (F type)

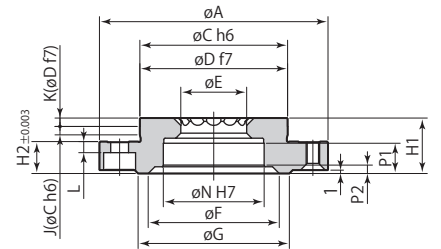
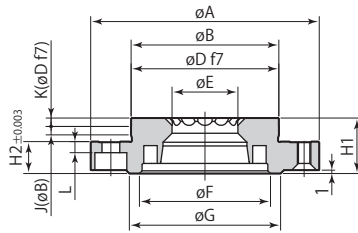
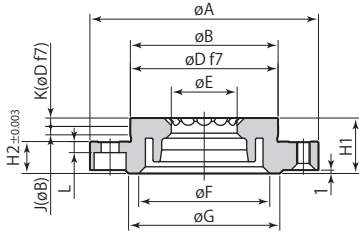

mm

Model	CPS-□03F	CPS-□06F	CPS-□10F
øA	55	68	75
øB	31 ^{+0.005} _{-0.011}	44 ^{+0.005} _{-0.011}	47 ^{+0.005} _{-0.011}
øC	31 ⁰ _{-0.016}	44 ⁰ _{-0.016}	47 ⁰ _{-0.016}
øD	31 ^{-0.025} _{-0.050}	44 ^{-0.025} _{-0.050}	47 ^{-0.025} _{-0.050}
øE	15.6	19.6	23.3
øF	28	39	42
øG	32	45	48
H1	15.5	16.5	20
H2	9	9.5	11.5
J	2.4	2.5	3.2
K	2.1	2.5	2.8
L	2.8	3.3	4.2
øM1	5.3	5.3	6.8
øM2	9.5	9.5	11
øN	22 ^{+0.021} ₀	30 ^{+0.021} ₀	32 ^{+0.025} ₀
P1	7	9	11
P2	2	2.5	2.5
R1	43	56	61
R2	46	59	64
S	8	12	12
T	M4×0.7	M4×0.7	M5×0.8
U*	45°	30°	30°

* : Be sure to match up phase of locate ring steel ball grooves and pallet clamp steel balls.

● Mounting screws are not included.

Shim (option)

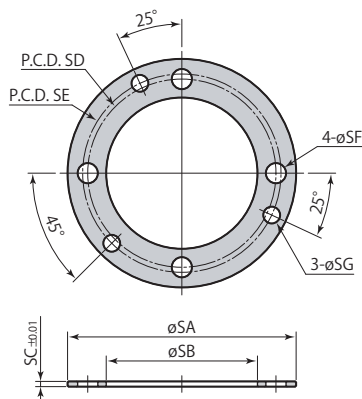

mm

Shim	CPS-S03F	CPS-S06F	CPS-S10F
øSA	55	68	75
øSB	32	45	48
SC	1.55	1.55	2.05
SD	43	56	61
SE	46	59	64
øSF	6	6	7
øSG	5	5	6
Mass	0.02 kg	0.02 kg	0.04 kg

● This diagram indicates dimensions at shipping.

● Adjust thickness of shim by grinding to ensure flatness of pallet.

Mounting details

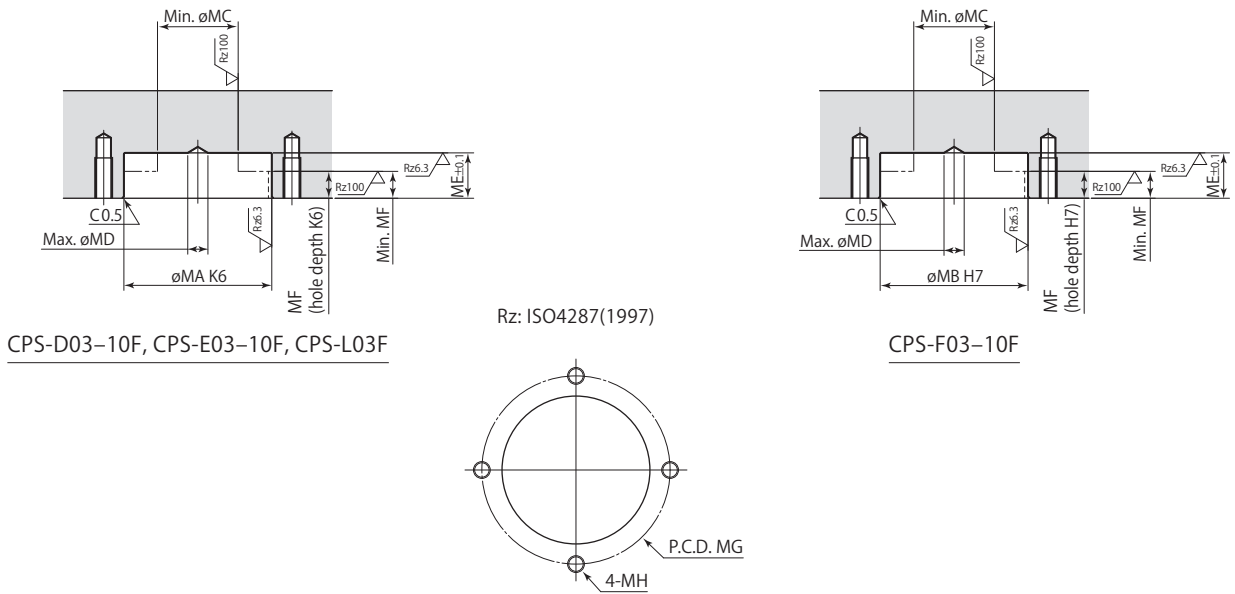

Model	CPS-□03F	CPS-□06F	CPS-□10F
øMA	31 ^{+0.003} _{-0.013}	44 ^{+0.003} _{-0.013}	47 ^{+0.003} _{-0.013}
øMB	31 ^{+0.025} ₀	44 ^{+0.025} ₀	47 ^{+0.025} ₀
øMC	20	24	28
øMD	6	6	8
MG	43	56	61
MH	M5	M5	M6

mm

Not using shim (standard specifications)

ME	10.5	13.5	14.8
MF	7.5	8	9.5

Using shim (shim specifications)

ME	9	12	12.8
MF	6.5	6.5	7.5

● Be sure to match up phase of locate ring steel ball grooves and pallet clamp steel balls.

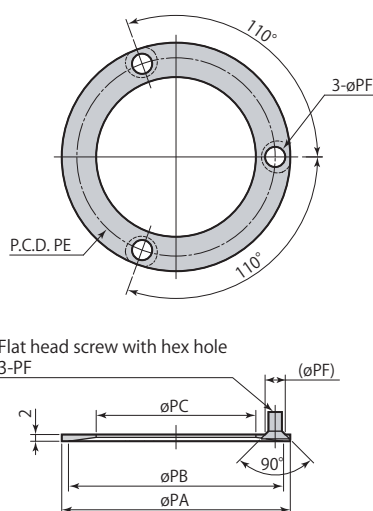

Protective plate (option)

Protective plate	CPS-P03F	CPS-P06F	CPS-P10F
øPA	55	68	75
øPB	51	64	68
øPC	34.5	47.5	50.5
PE	46	59	64
øPF	6	6	8
Mass	0.02 kg	0.02 kg	0.03 kg

mm

Pitch tolerance of Pal system

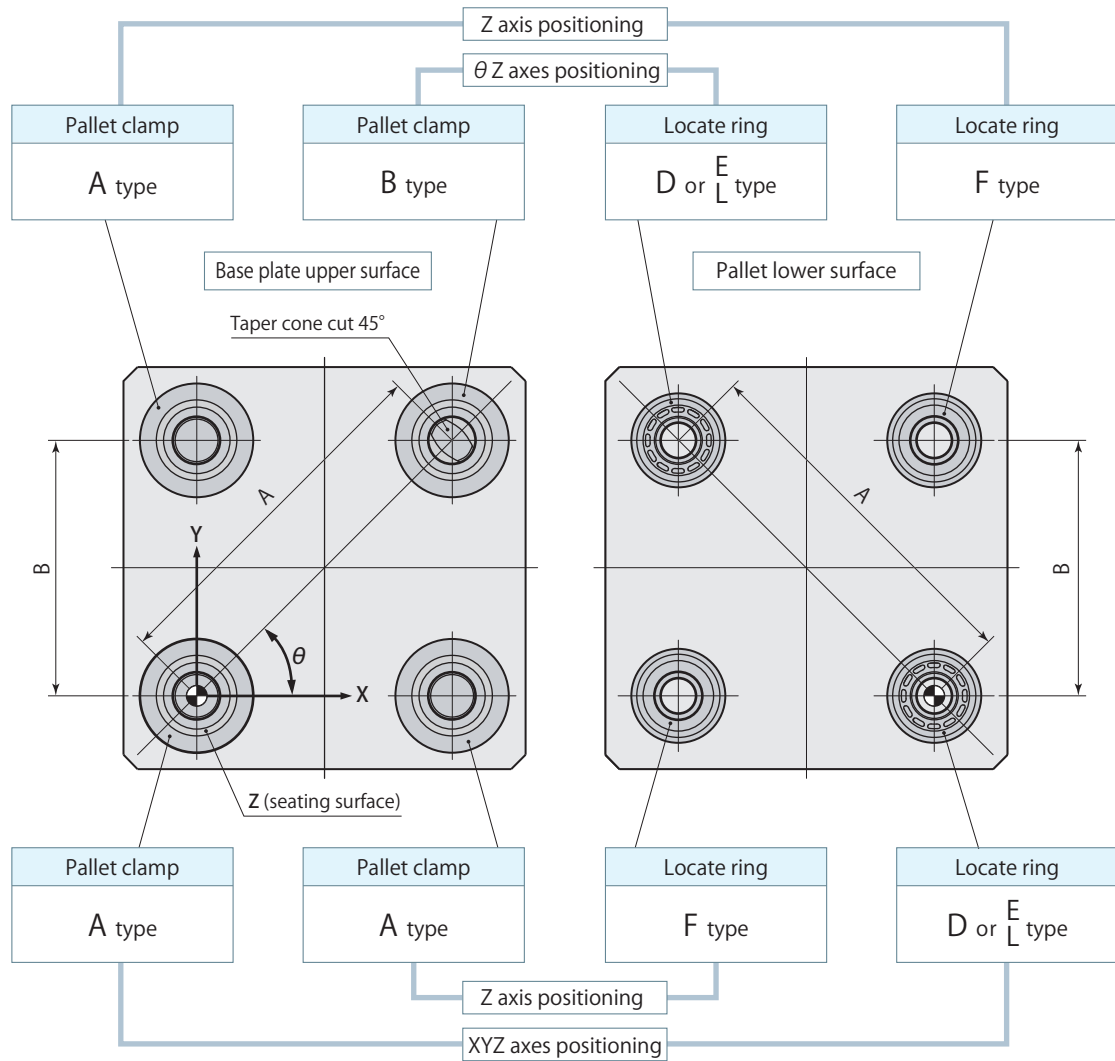

Pitch tolerance of A dimensions	±0.01 mm
Pitch tolerance of B dimensions	±0.03 mm

Method for positioning pallet changer setup table

Internal hole of model CPS-F (Seating surface positioning) can be used for positioning of setup table for pallet change with pallet changer. In order to sustain accuracy, do not allow surfaces other than those of pallet clamp model CPY to come into contact with tapered surface or seating surface.

Locate ring XYZ axes and θ Z axes positioning

Locate ring Z axis positioning

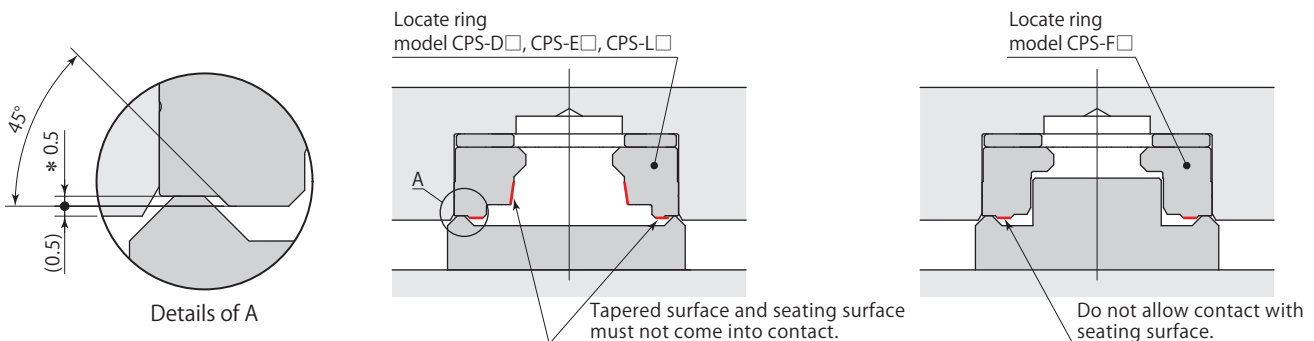

* : 1mm for CPS-□□F (Locate ring for flange mounting)

Pallet change

- When pallet changing, the pallet should be mounted or dismounted observing the figures shown in "Max. allowable eccentricity for pallet setting". (Refer to **page →43** for max. allowable eccentricity for pallet setting.)
- Ensure that pallet does not lean to the side when pallet mounting or dismounting. When dismounting pallet in particular, pulling while in a tilted condition can damage pallet clamp and locate ring. A guide pin is recommended to prevent the pallet from leaning.

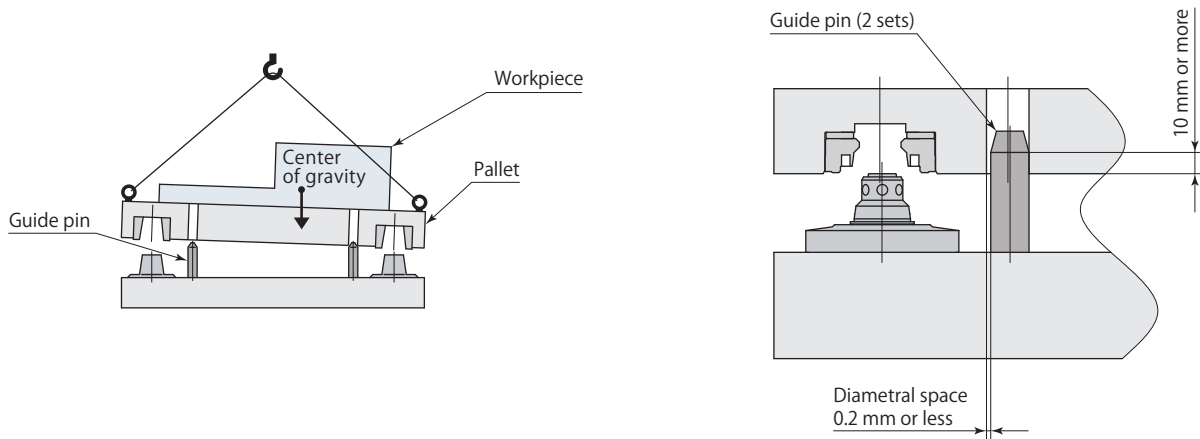

For vertical mounting of pallet

- A guide pin must be installed when mounting pallet vertically.
- Ensure spacing is set in order to ensure that mounted guide pin does not affect positioning.
- Ensure the pallet is closely contact with the base when it is clamped. Clamping with a space may cause the damage of both of clamp and locate ring.
(Refer to **page →49** for the height of pallet from base plate when pallet setting.)

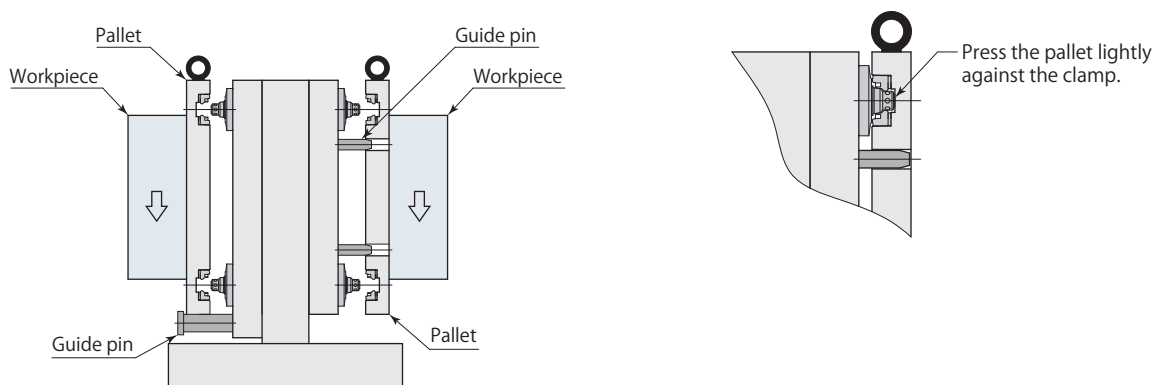

Level adjustment

Level adjustment of pallet clamp seating surface

- If level adjustment of pallet clamp seating surface is required, use pallet clamp shim (option). The level can be adjusted by grinding the shim.
- Grind shim upper surface (surface without O-ring).
- The measurement on the seating surface should be performed under the pallet clamped condition without locate rings.
(Recommended adjustment figure : $\pm 0.003\text{mm}$)

Level adjustment of locate ring seating surface

- If level adjustment of locate ring seating surface is required, use locate ring shim (option). The level can be adjusted by grinding the shim. (Recommended adjustment figure : $\pm 0.003\text{mm}$)

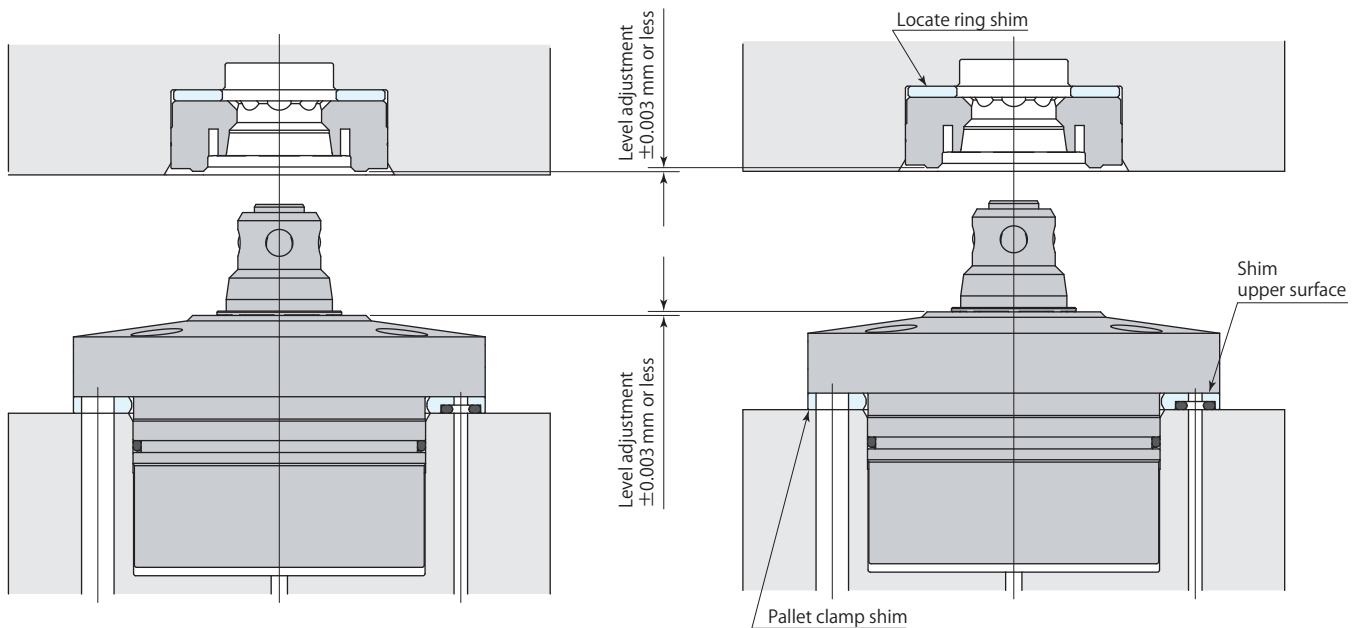

Dismounting of clamp

Dismounting of clamp

- ① Mount the set-screws on the mounting tap to protect the threads and clamp mounting surface.
- ② Mount the clamp removal screw on the clamp removal tap and dismount the clamp.
- ③ Retain the clamp upright condition when dismounting it.

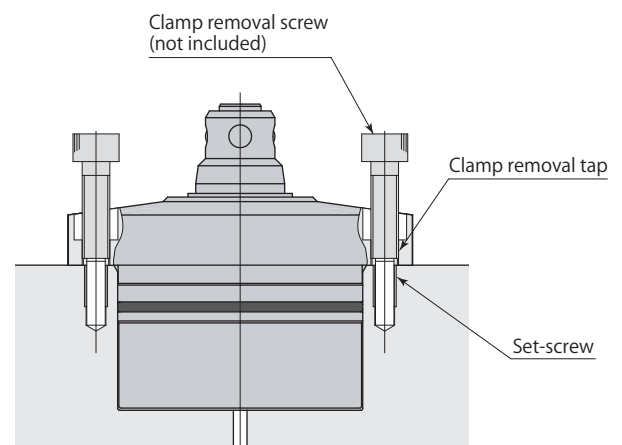

Air sensor unit recommended condition of use

Supplier and model	ISA3-F/G series manufactured by SMC
	GPS2-05, GPS3-E series manufactured by CKD
Air supply pressure	0.2 MPa
Inner diameter of piping	ø4 mm
Overall piping length	5 m or less

- Supply the dry and filtered air. Particulate size $5\ \mu\text{m}$ or less is recommended.
- Use a solenoid valve with needle for air sensor unit and control it supplying air all the time in order to eliminate intrusion of chips or coolant.

- There is a case that air sensing cannot be made successfully as designed when it is used out of the usage shown on the left. Contact Technical service center for more details.
- Refer to the sensor supplier's instruction manual for the details of setting.
- Sensing performance such as detectable time and pressure differs depending on the supplier and model number of the sensor. Select the right model referring to sensor's application and characteristics.
- Clamp state observation or operating check by the air sensor should be made while air blow is OFF.

Pneumatic circuit diagram

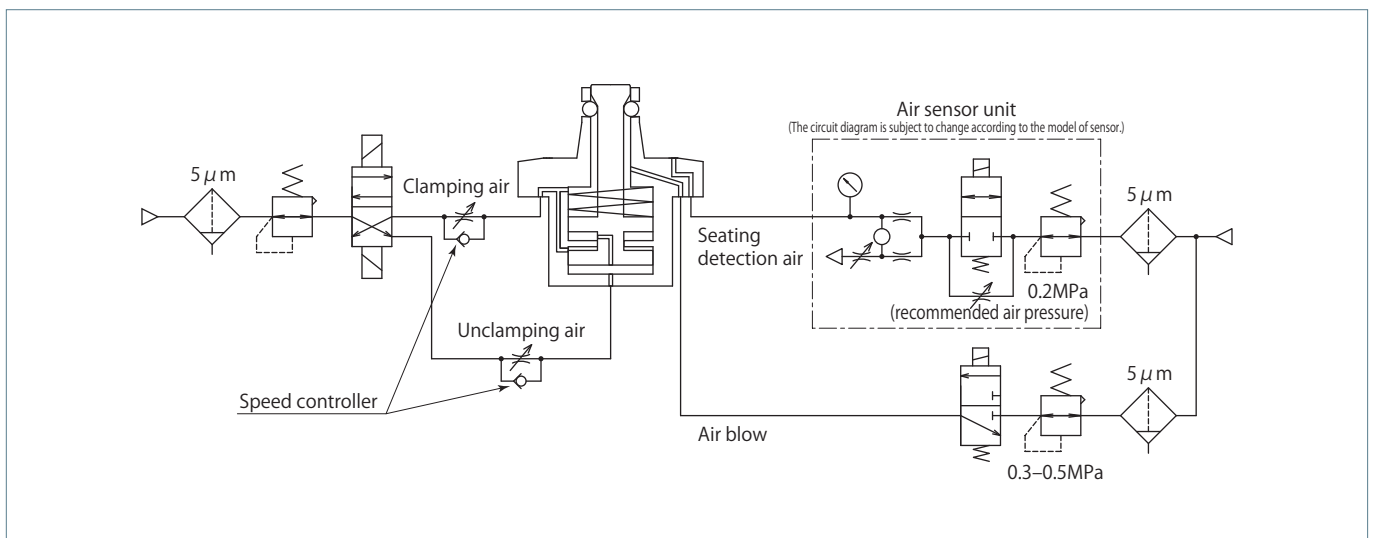

- Be sure to make inner diameter of air blow circuit 8 mm or more except for clamp mounting surface.
- Adjust full stroking time to be more than 1 second by a speed controller to avoid impact at the time of clamp or unclamp action.