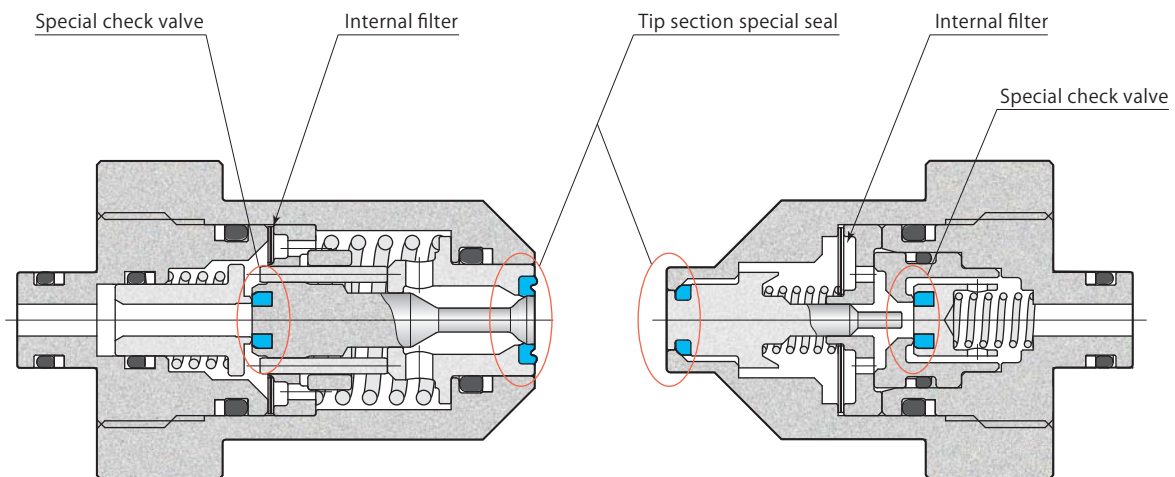

Special seal mechanism ensures leak of operating oil is zero for connecting and disconnecting

35 MPa Non-leak coupler socket

model **WVP-2SSH**

35 MPa Non-leak coupler plug

model **WVP-2SPH**

Spill amount (liquid drip amount per connection or disconnection) 0.01 mL or less

Specifications

- Special seal installed on the tip of coupler socket and coupler plug can minimize the intrusion of air and spill of working fluid during connection and disconnection, furthermore, it prevents corruption of coolant by being miscible with spilled working fluid and air contamination of clamp circuit.
- Model WVP-2S incorporates filter and protects internal check valves and clamps from foreign substances.
- Connection and disconnection, which had been difficult to perform with conventional couplers while hydraulic pressure is applied, can be performed smoothly.
- Pressure in the circuit is retained for a long time after disconnection of coupler.
- Jig pallet fabrication cost is kept low by using an economically priced plug for coupler of pallet.

Pressure range	7–35 MPa	Circuit symbol Socket hydraulic pressure source 35MPa Connect/disconnect under pressure Capable
Proof pressure	52.5 MPa	
Orifice area	12.5 mm ²	
Fluid used	General mineral based hydraulic oil (ISO-VG32 equivalent)	
Allowable eccentricity	±0.4 mm	
Allowable inclination	0.2° or less	
Reactive force*	154 N per 1 MPa fluid pressure	
	Max. spring force for no pressure 162 N	
Operating temperature	0–70 °C	
Mass	WVP-2SSH : 330g WVP-2SPH : 270g	

* : Reactive force (N) = Fluid pressure (MPa) × 154 + 162

- Supply operating oil from socket.
- Mixed use with model WVP-2H□H is not possible.

Non-leak coupler fixed
Horizontal mounting of coupler

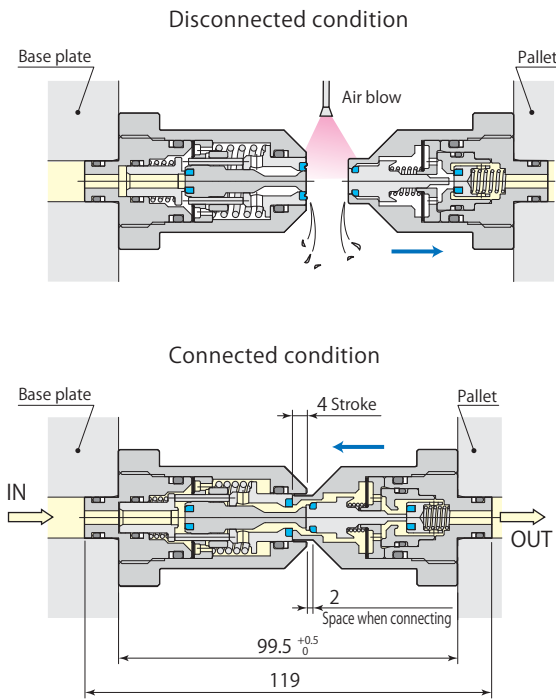

Non-leak coupler fixed
Coupler upper section hydraulic pressure supply

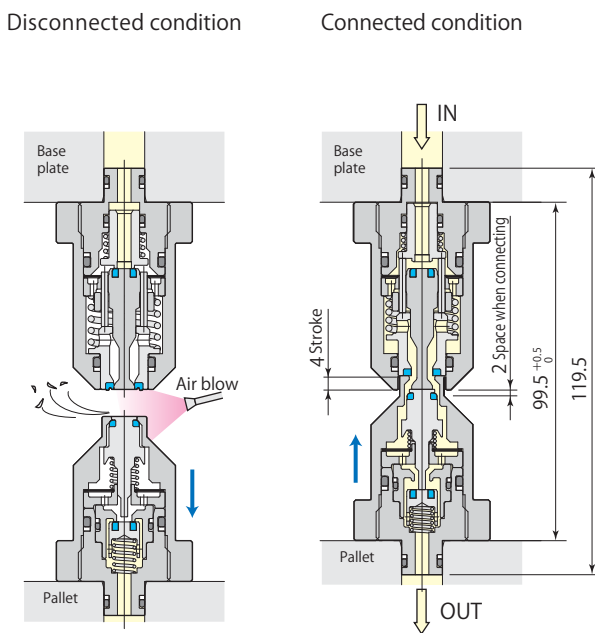

- Perform installation with plug below so metal chips are less likely to adhere and air blowing can be performed properly.

Dimensions

WVP-2SSH socket (fixed)

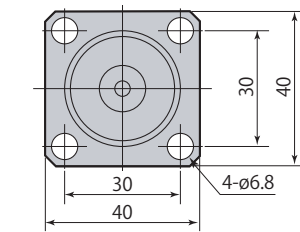
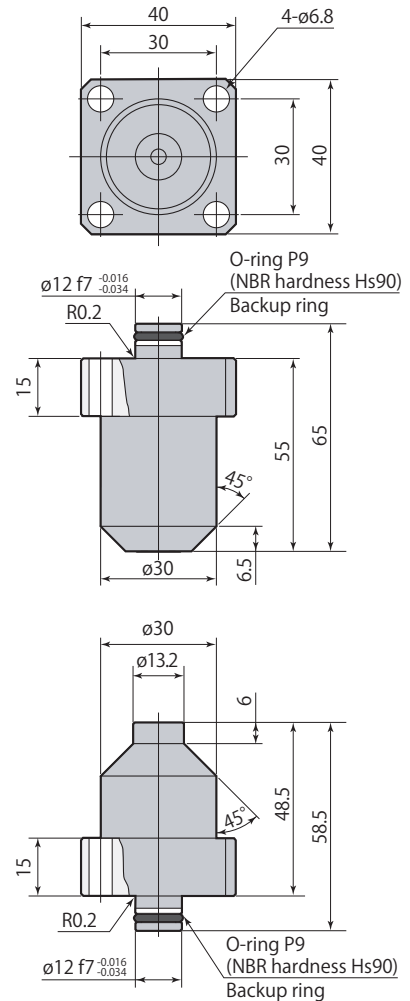

WVP-2SPH plug (fixed)

- Mounting screws are not included.

Mounting details

WVP-2SSH, WVP-2SPH

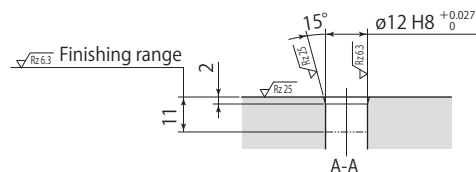
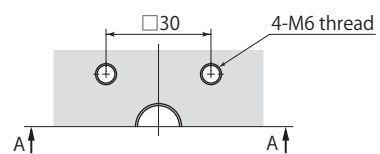

Rz: ISO4287(1997)