

Sensing **air** Link clamp

Double acting 1 MPa

model **CLX-T**



3 point sensor model
model CLX50-FT

Sensing **air Link clamp** model **CLX-T**

The extremely small sensing clamp can detect the loading miss and setting miss of a workpiece firmly.

3 point sensor model



- Sensor model can prevent tool breakage and defective machining due to incomplete clamp. (Figure 1)
- Unclamp PAL sensor moves along with the piston rod and can positively detect unclamping point, thereby enabling a high-speed production line by fully synchronizing operation with workpiece lifters.
- Built-in sensors enable a compact and simple jig.
- Unclamp detection failure due to the metal chips deposit on an independent external detector can be reduced. (Figure 2)

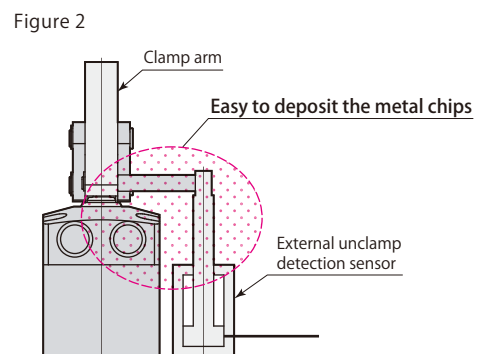
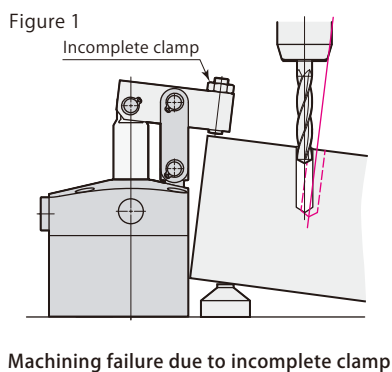

3 point sensor model T

Clamp, Unclamp, Over clamp stroke (Incomplete clamp) detection

model **CLX□-□T** PAT.

The 3 point sensor model can detect the status of clamp, unclamp and over clamp stroke with just 2 circuits of air.

Refer to **pages →70-73** for the details.

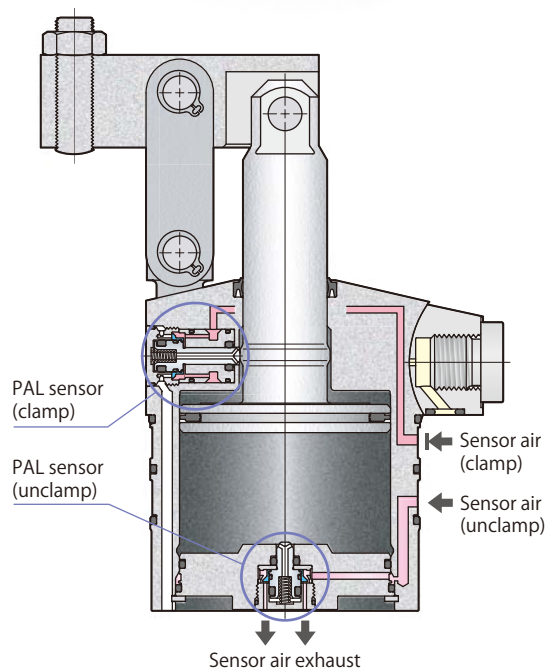
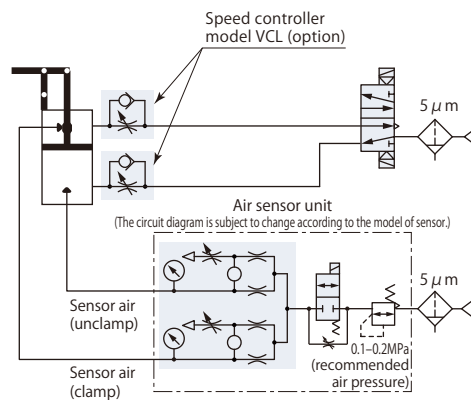
**Pneumatic circuit diagram**

Specifications

Size

CLX —

- 32
- 40
- 50
- 63

Clamp arm mounting direction

- L : Left side
- F : Front side
- R : Right side

T : 3 point sensor model
Clamp, Unclamp, Over clamp stroke (Incomplete clamp) detection

Model		CLX32-□T	CLX40-□T	CLX50-□T	CLX63-□T	
Cylinder force (air pressure 0.5MPa)	N	400	630	980	1560	
Cylinder inner diameter	mm	32	40	50	63	
Rod diameter	mm	14	16	20	25	
Effective area (clamp)	mm ²	804	1257	1963	3117	
Full stroke	mm	24	26	29.5	34.5	
Clamp stroke*1	mm	21	23	26.5	31.5	
Safety stroke	mm	3	3	3	3	
Cylinder capacity	Clamp	cm ³	19.3	32.7	57.9	107.5
	Unclamp	cm ³	15.6	27.4	48.7	90.6
Mass	kg	0.44	0.59	0.99	1.54	
Recommended tightening torque of mounting screws*2	N·m	4.0	4.0	5.9	5.9	

- Pressure range: 0.1–1 MPa
 - Proof pressure: 1.5 MPa
 - Operating temperature: 0–70 °C
 - Fluid used: Air*3
 - Oil supply: Not required
 - Seals are resistant to chlorine-based cutting fluid. (not thermal resistant specification)
- *1: Indicates a distance from unclamping position to clamping point.
 *2: ISO R898 class 12.9 *3: Supply the dry and filtered air. Particulate size 5 μm or less is recommended.

When clamping the workpiece, the clamp arm should be situated like the sketch as shown below. (Clamping point)
 Please avoid any non-axial force such as the bending moment toward the piston rod. (Allowable angle ±3°)

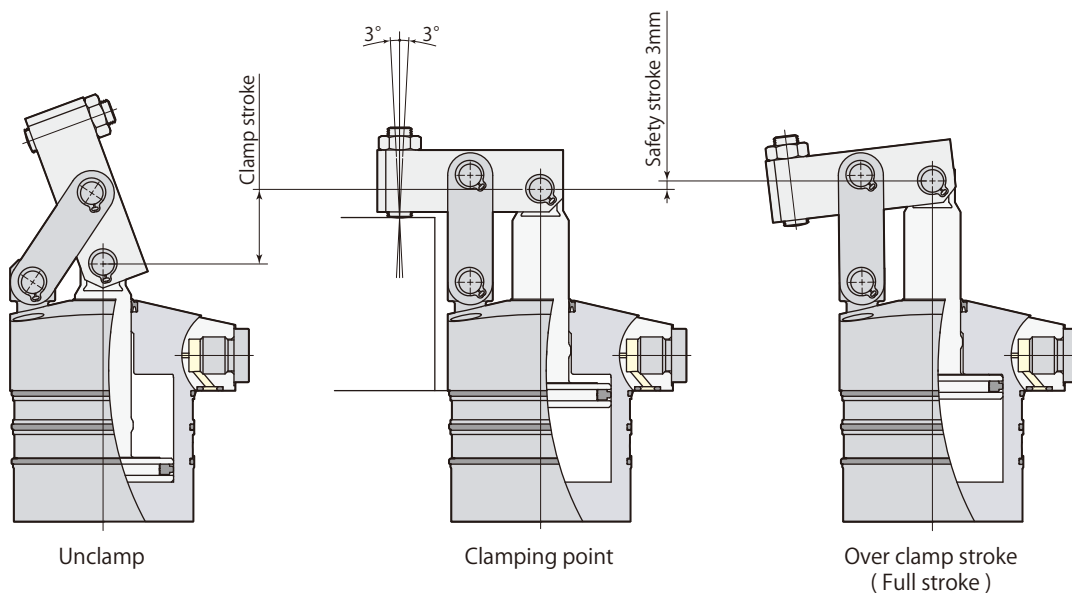

Manifold piping and G port piping are available.

Manifold piping

When choosing manifold piping, a speed controller model VCL is mountable on the G ports of the clamp.

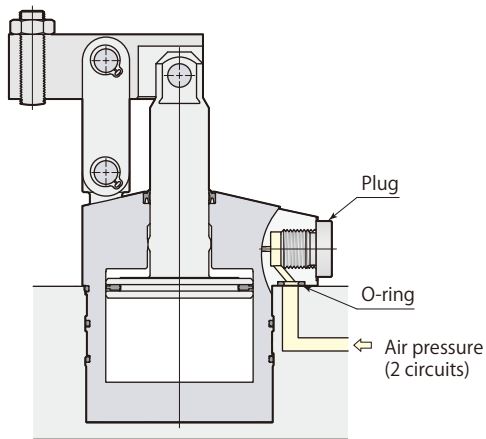

G port piping

When choosing G port piping, remove plugs. (O-ring must be used.) The one touch fitting or the speed controller with one touch fitting should be mounted when choosing G port piping.

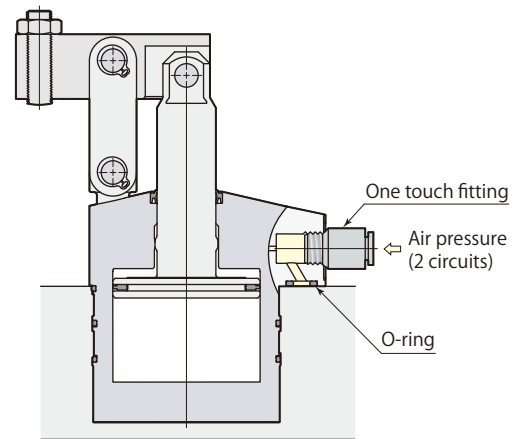

Speed controller model VCL

Page →118

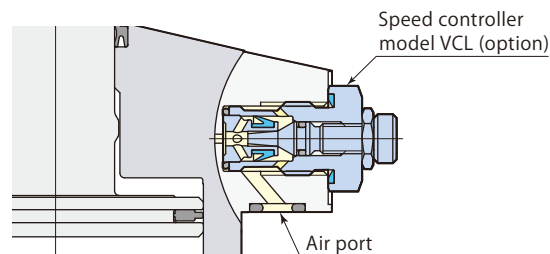

Performance diagram

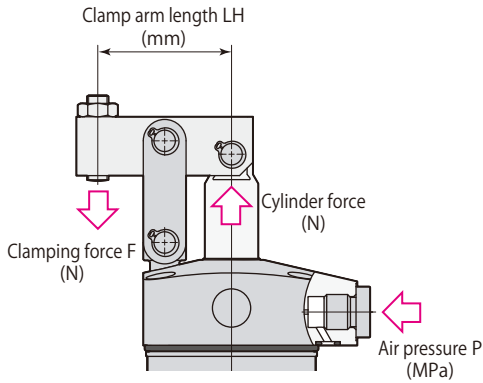

Clamping force varies depending on the clamp arm length (LH) and air pressure (P).

Clamping force calculation formula

$$F = \text{Coefficient 1} \times P \times 1000 / (\text{LH} - \text{Coefficient 2})$$

F: Clamping force P: Air pressure LH: Clamp arm length

CLX50-T with clamp arm length (LH) 50 mm at air pressure of 0.5 MPa, Clamping force F is calculated by $44.18 \times 0.5 \times 1000 / (50 - 25.0) = 880 \text{ N}$

Do not use the clamp in the nonusable range. It may cause damage of link mechanism.

model CLX32-□T

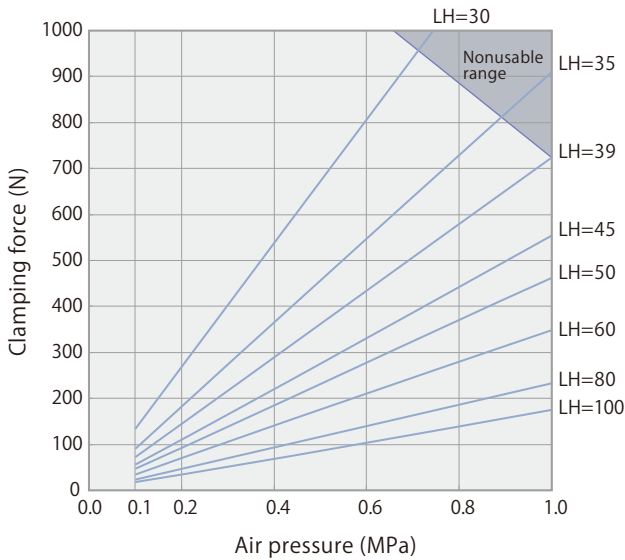

model CLX40-□T

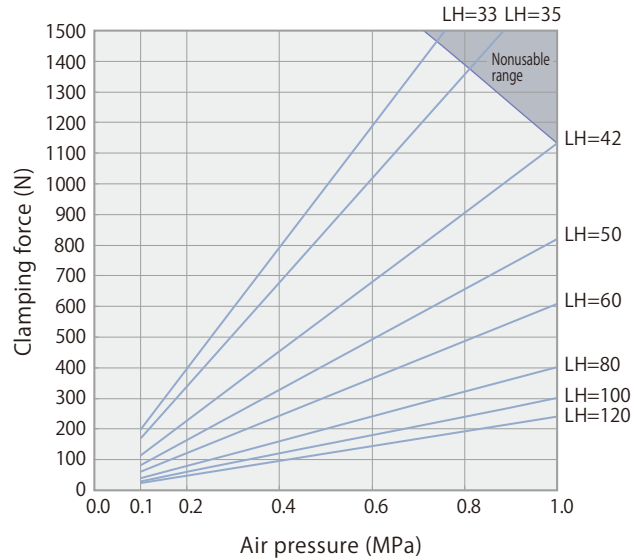

model CLX50-□T

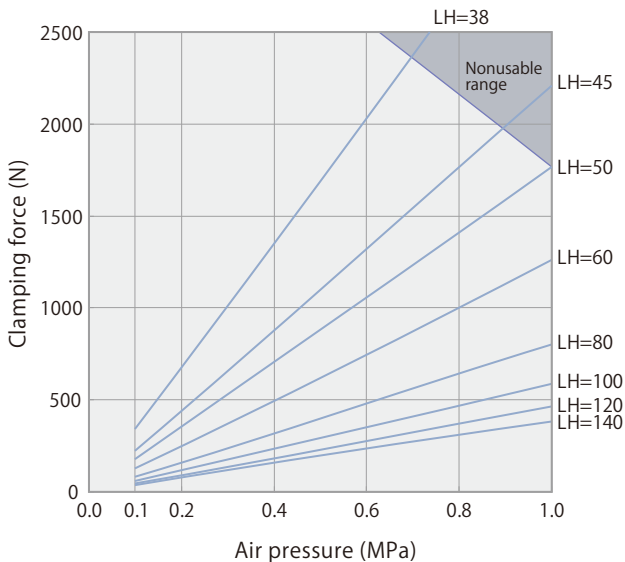

model CLX63-□T

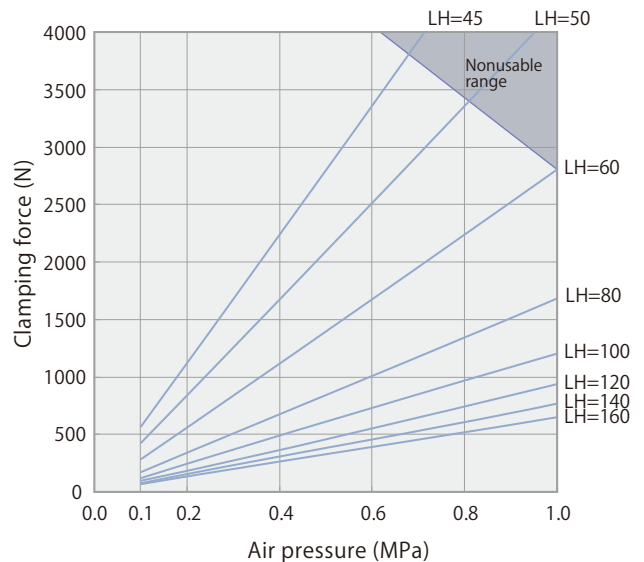

Performance table

model CLX32-□T Clamping force $F=14.11 \times P \times 1000 / (LH-19.5)$

Air pressure MPa	Cylinder force N	Clamping force N								Min. arm length Min. LH mm
		Clamp arm length LH mm								
		30	35	39	45	50	60	80	100	
1.0	800			720	550	460	350	230	180	39
0.9	720			650	500	420	310	210	160	36
0.8	640		730	580	440	370	280	190	140	33
0.7	560	940	640	510	390	320	240	160	120	30
0.6	480	810	550	430	330	280	210	140	110	28
0.5	400	670	460	360	280	230	170	120	90	26
0.4	320	540	360	290	220	190	140	90	70	↑
0.3	240	400	270	220	170	140	100	70	50	↑
0.2	160	270	180	140	110	90	70	50	40	↑
0.1	80	130	90	70	60	50	30	20	20	26

■ indicates nonusable range

model CLX40-□T Clamping force $F=23.75 \times P \times 1000 / (LH-21.0)$

Air pressure MPa	Cylinder force N	Clamping force N								Min. arm length Min. LH mm
		Clamp arm length LH mm								
		33	35	42	50	60	80	100	120	
1.0	1260			1130	820	610	400	300	240	42
0.9	1130			1020	740	550	360	270	220	38
0.8	1010		1360	900	660	490	320	240	190	35
0.7	880	1390	1190	790	570	430	280	210	170	32
0.6	750	1190	1020	680	490	370	240	180	140	30
0.5	630	990	850	570	410	300	200	150	120	29
0.4	500	790	680	450	330	240	160	120	100	↑
0.3	380	590	510	340	250	180	120	90	70	↑
0.2	250	400	340	230	160	120	80	60	50	↑
0.1	130	200	170	110	80	60	40	30	20	29

■ indicates nonusable range

model CLX50-□T Clamping force $F=44.18 \times P \times 1000 / (LH-25.0)$

Air pressure MPa	Cylinder force N	Clamping force N								Min. arm length Min. LH mm
		Clamp arm length LH mm								
		38	45	50	60	80	100	120	140	
1.0	1960			1770	1260	800	590	470	380	50
0.9	1770			1590	1140	720	530	420	350	46
0.8	1570		1770	1410	1010	640	470	370	310	42
0.7	1370		1550	1240	880	560	410	330	270	39
0.6	1180	2040	1330	1060	760	480	350	280	230	36
0.5	980	1700	1100	880	630	400	290	230	190	34
0.4	790	1360	880	710	500	320	240	190	150	↑
0.3	590	1020	660	530	380	240	180	140	120	↑
0.2	390	680	440	350	250	160	120	90	80	↑
0.1	200	340	220	180	130	80	60	50	40	34

■ indicates nonusable range

model CLX63-□T Clamping force $F=84.16 \times P \times 1000 / (LH-30.0)$

Air pressure MPa	Cylinder force N	Clamping force N								Min. arm length Min. LH mm
		Clamp arm length LH mm								
		45	50	60	80	100	120	140	160	
1.0	3120			2810	1680	1200	940	770	650	60
0.9	2810			2520	1510	1080	840	690	580	55
0.8	2490		3370	2240	1350	960	750	610	520	50
0.7	2180		2950	1960	1180	840	650	540	450	46
0.6	1870	3370	2520	1680	1010	720	560	460	390	43
0.5	1560	2810	2100	1400	840	600	470	380	320	40
0.4	1250	2240	1680	1120	670	480	370	310	260	↑
0.3	940	1680	1260	840	500	360	280	230	190	↑
0.2	620	1120	840	560	340	240	190	150	130	↑
0.1	310	560	420	280	170	120	90	80	60	40

■ indicates nonusable range

Sensing Air link clamp CLX-T 3 point sensor model

PAL sensor function and structure

Sensing Air link clamp
CLX-T
3 point sensor model

Unclamp detection

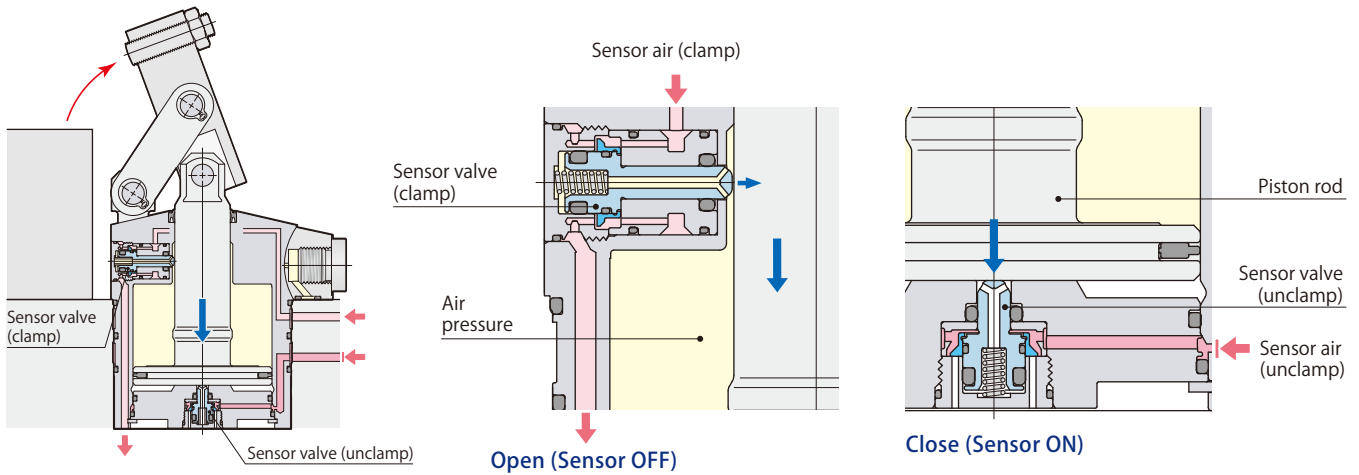

- The sensor valve (unclamp) is pushed down by the piston rod and shuts off the sensor air flow when the piston rod reaches the unclamp end. The sensor valve (clamp) is pushed up by the air pressure to open for air exhaust and detects the unclamped condition.

Clamp detection

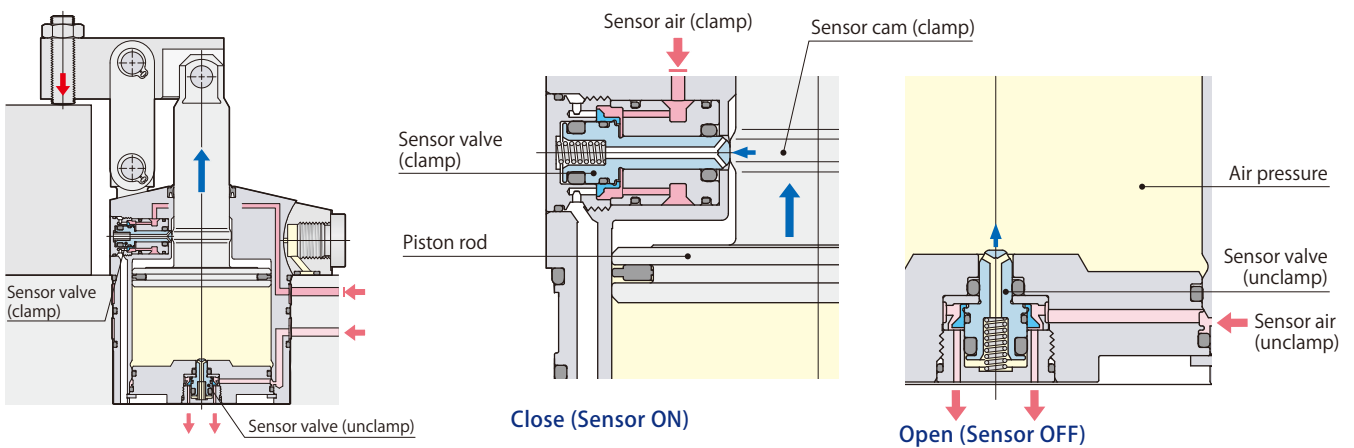

- The sensor valve (clamp) is pushed down by the sensor cam (clamp) and shuts off the sensor air flow when the piston rod reaches the clamping point. The sensor valve (unclamp) is pushed up by the air pressure to open for air exhaust and detects the clamped condition.

PAL sensor function and structure

Over clamp stroke (Incomplete clamp) detection

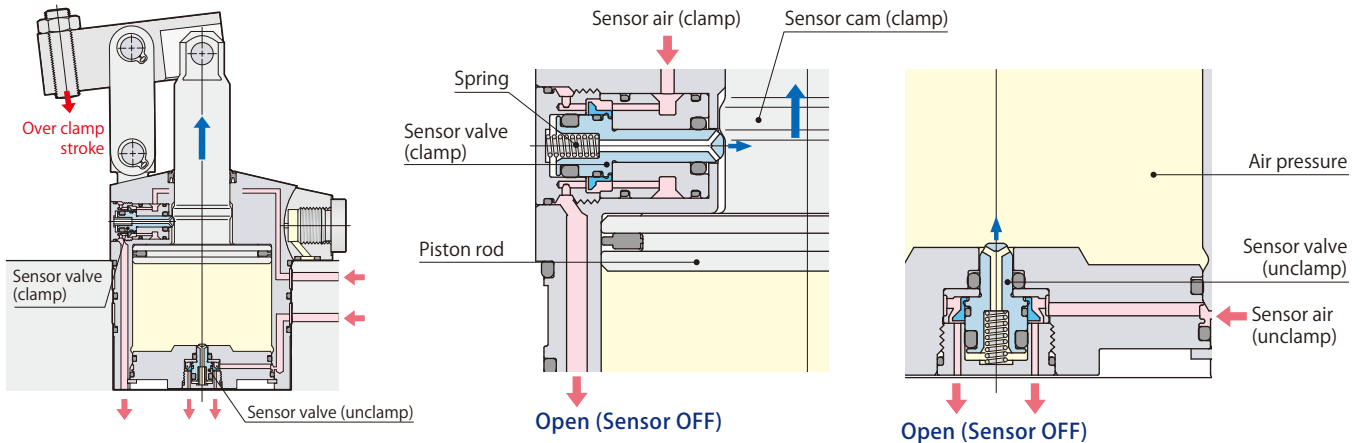

- The sensor cam passes the clamping point, the sensor valve (clamp) is pushed up by the spring and exhausts the sensor air. Also the sensor valve (unclamp) exhausts the air and detects the over clamp stroked (incomplete clamp) condition.

Over clamp stroke (Incomplete clamp) detection example

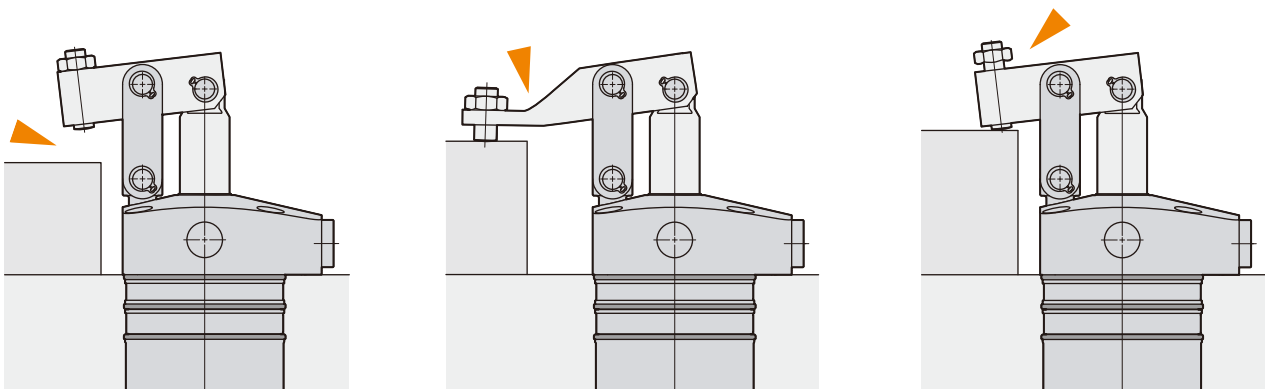

- Clamp disabled due to missetting workpiece.

- Clamp disabled due to the deflection of clamp arm.

- Clamp disabled due to the damage of piston rod or loose adjustment bolt.

- Clamp disabled due to the abrasion on the tip of clamp arm during prolonged use.

Clamp, Unclamp, Over clamp stroke detection signal

Unclamp detection

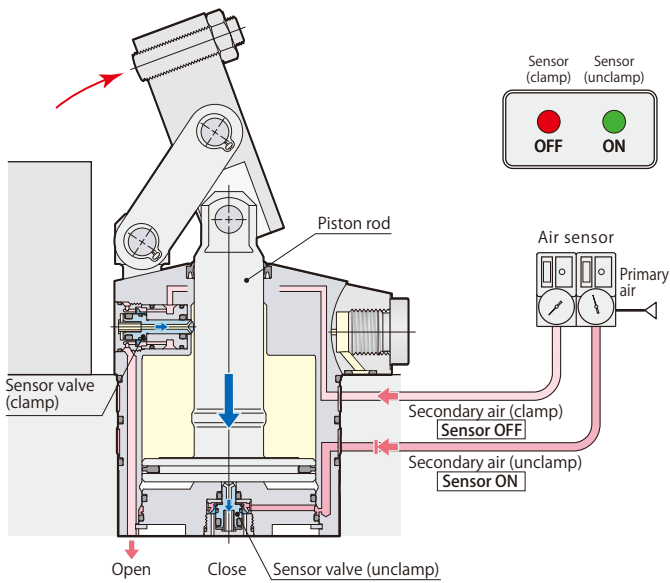

Sensor signal (clamp)	OFF	Unclamp
Sensor signal (unclamp)	ON	

In the middle of clamp stroke

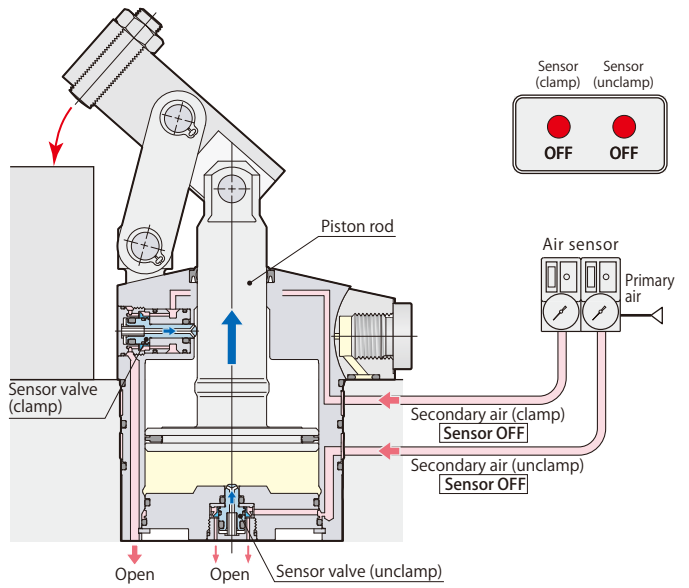

Sensor signal (clamp)	OFF	In the middle of clamp stroke
Sensor signal (unclamp)	OFF	

Clamp detection

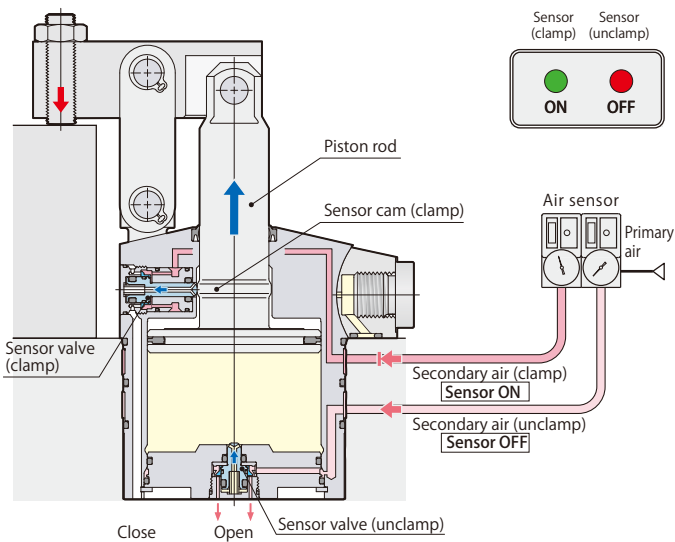

Sensor signal (clamp)	ON	Clamp
Sensor signal (unclamp)	OFF	

Over clamp stroke (Incomplete clamp) detection

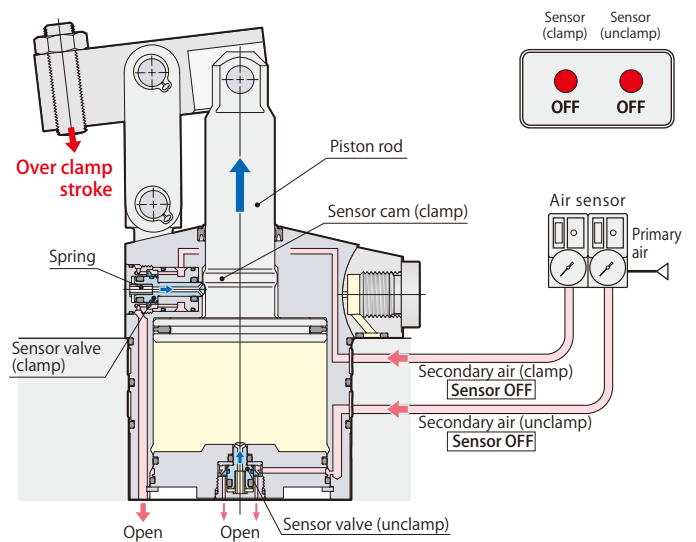

Sensor signal (clamp)	OFF	Over clamp stroke (Incomplete clamp)
Sensor signal (unclamp)	OFF	

Sensing Air link clamp

CLX-T 3 point sensor model

Air sensor triggering point

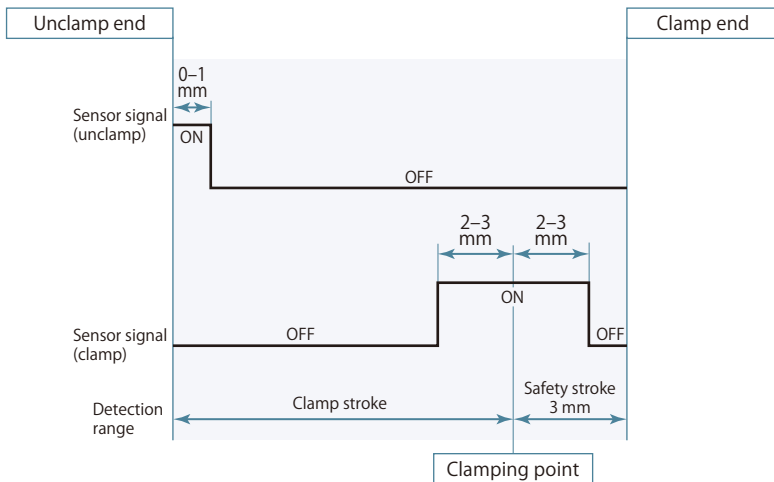

- Refer to the sensor supplier's instruction manual for the details of setting.
- Sensing performance such as detectable time and pressure differs depending on the supplier and model number of the sensor. Select the right model referring to sensor's application and characteristics.

Air sensor unit recommended condition of use

Supplier and model	ISA3-F/G series manufactured by SMC GPS2-05, GPS3-E series manufactured by CKD
Air supply pressure	0.1–0.2 MPa
Inner diameter of piping	ø4 mm (ISA3-F:ø2.5 mm)
Overall piping length	5 m or less

- Supply the dry and filtered air. Particulate size 5 μm or less is recommended.
- Use a solenoid valve with needle for air sensor unit and control it supplying air all the time in order to eliminate intrusion of chips or coolant.
- There is a case that air sensing cannot be successfully made as designed when it is used out of the above usage. Contact Technical service center for more details.

Relation between sensor air pressure, PAL sensor and piston stroke

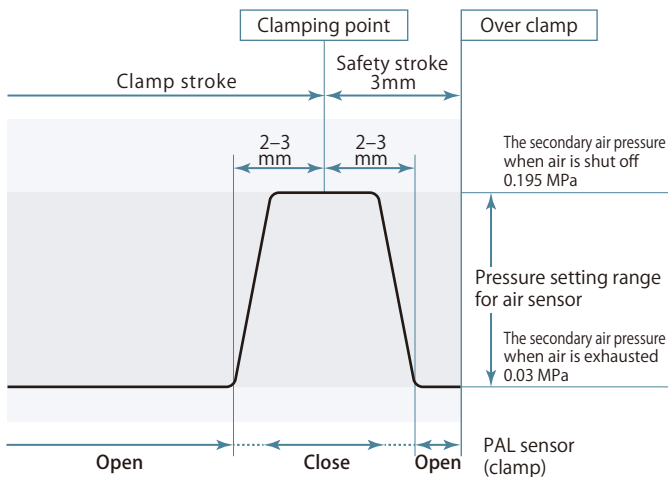
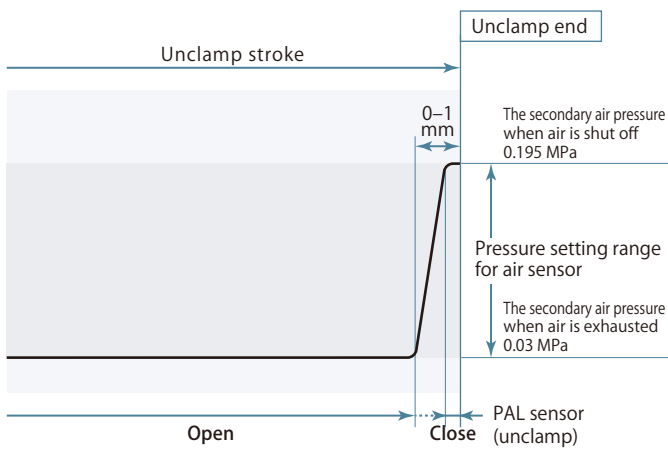

The diagram shown on the left indicates the relation between the PAL sensor, piston stroke, and secondary air pressure. (The pressure shown in the diagram is a reference based on the 0.2 MPa of primary air pressure for one piece of clamp.)

Since the new PAL sensor works with less air-leakage compared to previous sensor valve,

- Enhances the pressure setting range of the sensor which enables the sensor to set easily. (Ex. Pressure setting range 0.03–0.195 MPa in the diagram)
- Allows the use for a number of clamps by one air sensor because of better pressure holding when air is shut off. (Maximum number of clamps to be detected by one sensor is 10.)
- Allows to choose less air-consumed, i.e. small orifice diameter type, air sensor.
- Can create large differential-pressure when opening and closing the PAL sensor so that sensor primary pressure can be set as low as possible and reduce the consumption of air.

New PAL sensor

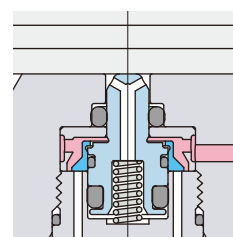

Poppet structure ensures superior sealing performance and can create large differential-pressure when the valve is opening and closing, and air leakage can be minimized.

Previous sensor valve

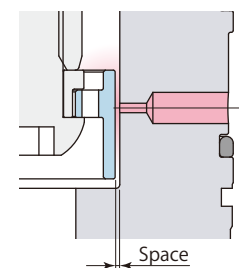

Air leaks easily due to a large space.

Dimensions

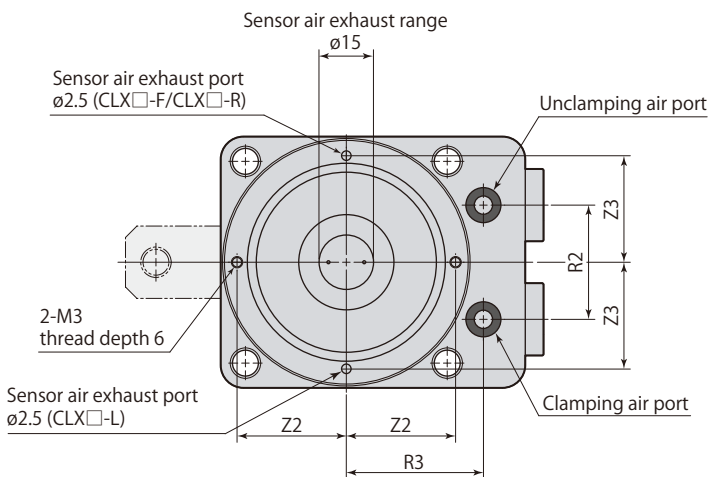
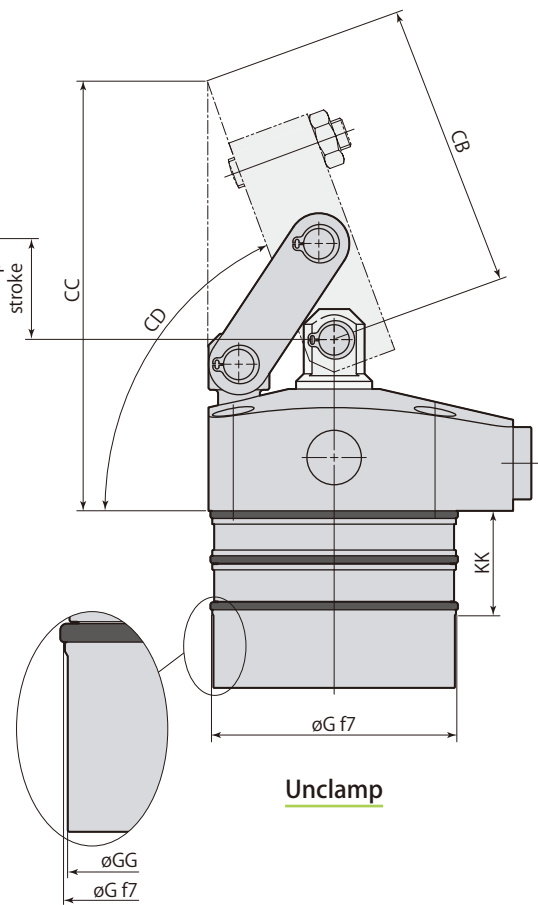
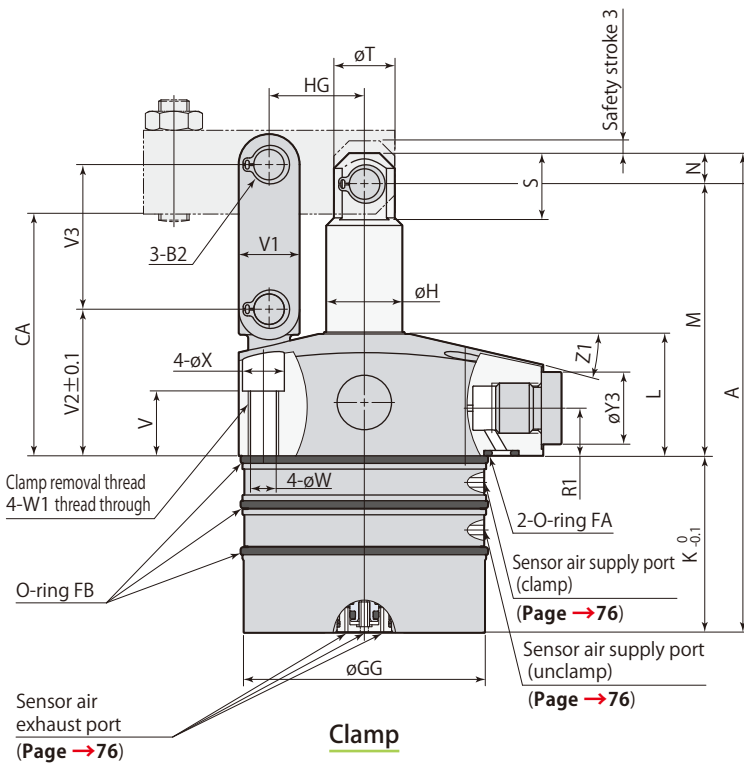
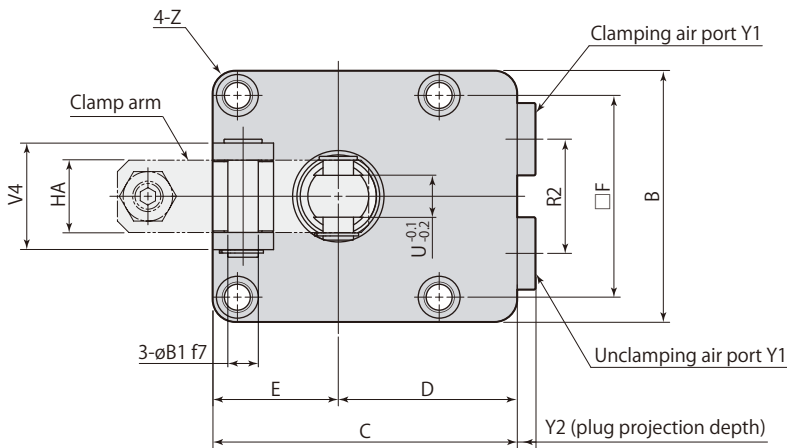

This diagram represents external contour of CLX□-FT, CLX□-LT and CLX□-RT differ only in terms of mounting direction of clamp arm and otherwise all dimensions are identical to those of CLX□-FT.

L: Left side F: Front side R: Right side

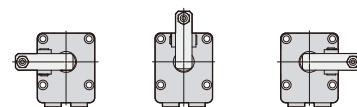

- Clamp arm and mounting screws are not included.
- Use a snap ring (B2) and a pin (øB1) when installing a clamp arm.

CLX□-□T	Air link clamp 3 point sensor model	air	Double acting
----------------	--	------------	----------------------

Model	CLX32-□T	CLX40-□T	CLX50-□T	CLX63-□T
A	101.5	110	126	144.5
B	50	56	66	78
C	60	66	80	91
D	35	38	47	52
E	25	28	33	39
F	39	45	53	65
øG	46 ^{-0.025 -0.050}	54 ^{-0.030 -0.060}	64 ^{-0.030 -0.060}	77 ^{-0.030 -0.060}
øGG	45.4	53.4	63.4	76.4
øH	14	16	20	25
K	39.5	43	46.5	56
KK	27	27	27	29
L	27	27	32	32
M	57	61	71.5	78.5
N	5	6	8	10
R1	11	11	12.5	12.5
R2	20	26	30	40
R3	28	31	36	41
S	11.5	14	17.5	21.5
øT	11	12	16	21
U (width across flats)	7	8	11	13
V	14	14	17	17
V1	10	12	16	18
V2	31.5	33	38.5	39.5
V3	28.5	32	38	44
V4	20	25	28	34
øW	5.5	5.5	6.8	6.8
W1	M6	M6	M8	M8
øX	9.5	9.5	11	11
Y1	G1/8	G1/8	G1/4	G1/4
Y2	3.8	3.8	4.8	4.8
øY3	14	14	19	19
Z	R5	R5	R6	R6
Z1	15°	15°	13°	13°
Z2	19.5	23.5	28.7	35.3
Z3	19.2	23.2	28	34.7
øB1	5 ^{-0.010 -0.022}	6 ^{-0.010 -0.022}	8 ^{-0.013 -0.028}	10 ^{-0.013 -0.028}
B2 (snap ring)*1	STW-5	STW-6	STW-8	STW-10
CA	52	55	63.5	69.5
CB	59.1	72.5	73.3	82.4
CC	89.7	105.2	110.9	120.2
CD	About 70°	About 72°	About 70°	About 68°
HA	14	16	19	22
HG	19.5	21	25	30
O-ring FA (FKM-90)	P6	P6	P6	P6
O-ring FB (FKM-70)	AS568-030	AS568-033	AS568-036	AS568-040
Speed controller*2	Meter-in	VCL01-I	VCL02-I	VCL02-I
	Meter-out	VCL01-O	VCL01-O	VCL02-O

*1: Snap ring is made by Ochiai Corporation.

*2: Select the right model of VCL according to the size of the clamp.

● Refer to **page →118** for the details of speed controller.

Mounting details

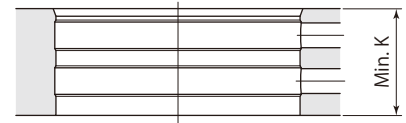
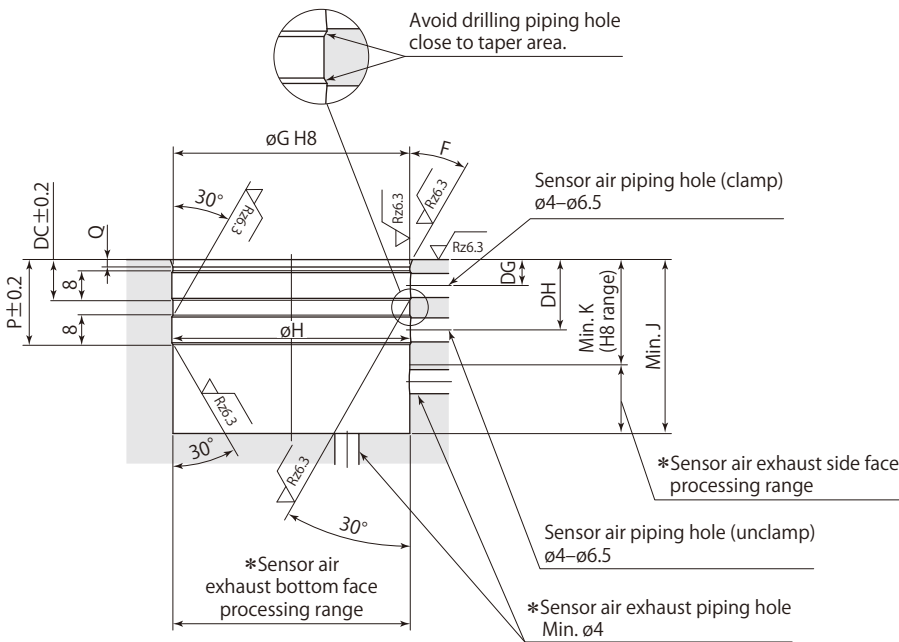
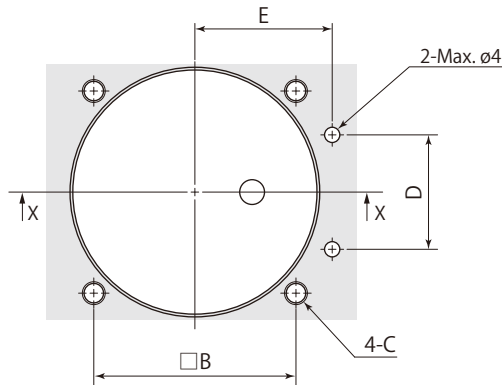

In through hole X-X

In blind hole X-X

*: Sensor air exhaust piping hole must be made on either side or bottom face.

Rz: ISO4287(1997)

- Apply an appropriate amount of grease to the chamfer and the bore when mounting. Excessive grease may be a blockage in the air passage, causing malfunction of the sensor.
- The 30° taper machining must be provided to avoid the damage of the O-ring. Ensure that there are no interference on taper area when drilling the hole for sensor air.

- No sensor air piping hole (unclamp) is needed unless unclamp sensor is used. Contact Pascal for the details.
- The sensor air piping hole can be used for a pilot hole of Rc 1/16 plug.

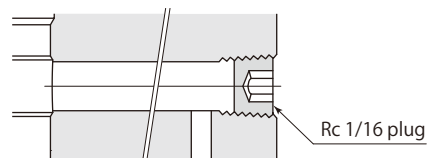

Mounting details

Model	mm			
	CLX32-□T	CLX40-□T	CLX50-□T	CLX63-□T
B	39	45	53	65
C	M5	M5	M6	M6
D	20	26	30	40
E	28	31	36	41
F	20°	20°	20°	30°
øG	46 ^{+0.039} ₀	54 ^{+0.046} ₀	64 ^{+0.046} ₀	77 ^{+0.046} ₀
øH	46.6	54.6	64.6	77.6
J	40	43.5	47	56.5
K	28	28	28	30
P	23	23	23	25
Q	2	2	2	1
DC	11	11	11	13
DG	7	7	7	9
DH	19	19	19	21

Caution for piping

Refer to the diagram shown below for the sensor air exhaust port.

Mounting in blind hole
(Sensor air exhaust : side face)

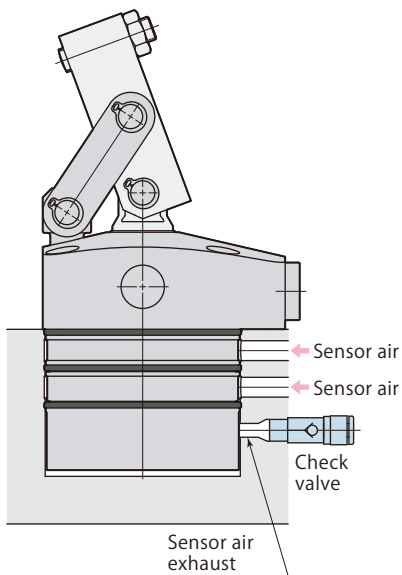

Mounting in blind hole
(Sensor air exhaust : bottom face)

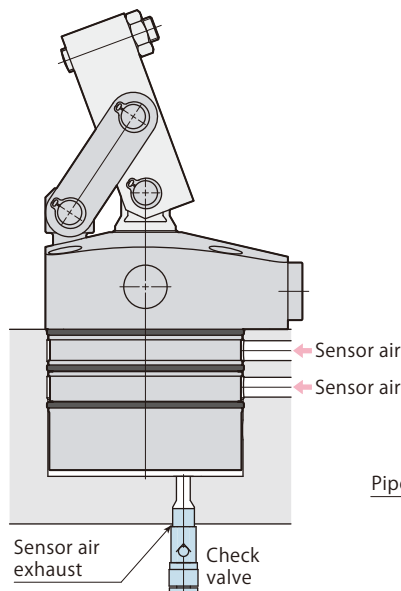

Mounting in through hole

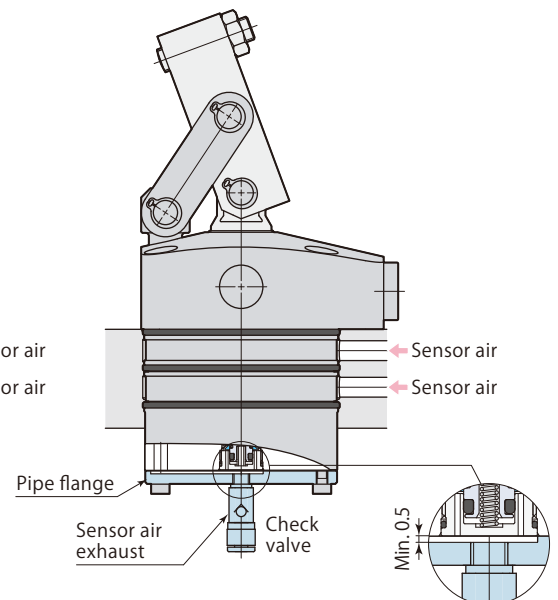

- Use a check valve with cracking pressure of 0.005 MPa or less if there is a risk of metal chips or coolant intrusion. Recommended check valve : AKH or AKB series manufactured by SMC.
- Furnish the piping by means of the pipe flange when mounting in a through hole. The flange is mountable with M3 threads at the bottom of the clamp. Be sure to provide an opening not to cover the exhaust port. See the sketch shown above.

Clamp arm mounting details

Clamp arm is not included. Manufacture a clamp arm with the dimensions shown in the table below.

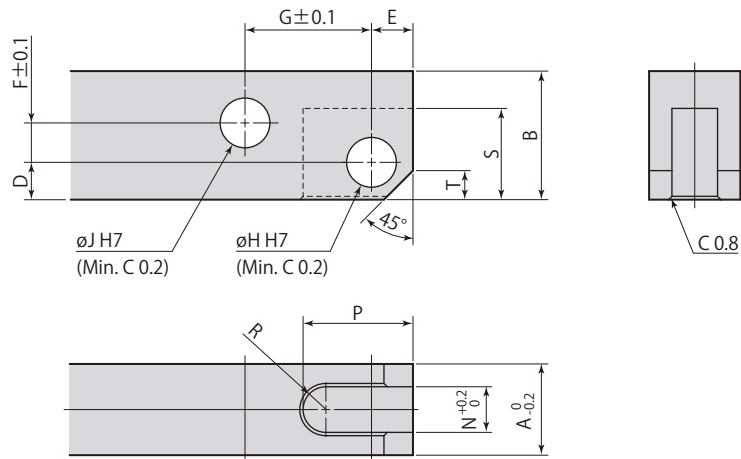

Recommended material: S45C (HB167–229)

Link clamp	mm			
	CLX32-□T	CLX40-□T	CLX50-□T	CLX63-□T
A	14	16	19	22
B	16	19	22	25
D	5	6	8	9
E	5	6	8	10
F	3	4	5	5
G	19.5	21	25	30
$\varnothing H$	$5^{+0.012}_0$	$6^{+0.012}_0$	$8^{+0.015}_0$	$10^{+0.015}_0$
$\varnothing J$	$5^{+0.012}_0$	$6^{+0.012}_0$	$8^{+0.015}_0$	$10^{+0.015}_0$
N	7	8	11	13
P	16	20	22	27
R	R3.5	R4	R5.5	R6.5
S	12	15	18	22
T	3	4	5	6

● When mounting the clamp arm, use included pins and snap rings.

Clamp arm allowable eccentricity

An eccentric shape clamp arm, as shown in diagram on right can be used with link clamp model CLX-T, if it is not possible to set clamping point at tip section of clamp arm in alignment with center line of piston rod and clamp arm.

Amount of eccentricity, however, must be within allowable eccentricity shown below.

Using a clamp arm that exceeds allowable eccentricity results in significant eccentric load on link mechanism and piston rod, leading to malfunction.

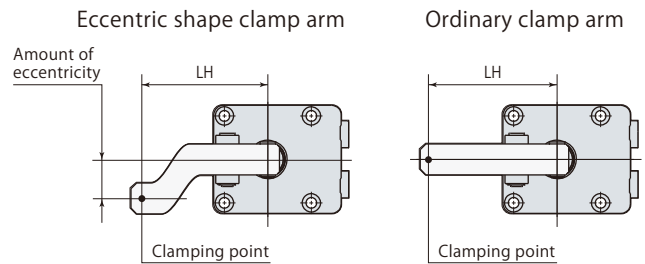

model CLX32-□T		indicates nonusable range						
Air pressure MPa	Allowable eccentricity mm							
	Clamp arm length LH mm							
	30	35	39	45	50	60	80	100
1.0					7	12	24	35
0.9				8	11	18	32	47
0.8			7	12	17	26	44	60
0.7		7	12	18	24	35	58	↑
0.6	5	12	18	26	34	48	60	↑
0.5	9	19	26	38	47	60	↑	↑
0.4	16	29	39	54	60	↑	↑	↑
0.3	28	46	60	60	↑	↑	↑	↑
0.2	51	60	↑	↑	↑	↑	↑	↑
0.1	60	60	60	60	60	60	60	60

model CLX40-□T		indicates nonusable range						
Air pressure MPa	Allowable eccentricity mm							
	Clamp arm length LH mm							
	33	35	42	50	60	80	100	120
1.0				6	13	26	39	53
0.9			5	11	20	36	53	70
0.8			9	17	28	49	70	80
0.7	3	6	15	25	39	65	80	↑
0.6	7	11	23	36	53	80	↑	↑
0.5	14	18	33	51	73	↑	↑	↑
0.4	23	29	50	73	80	↑	↑	↑
0.3	38	47	77	80	↑	↑	↑	↑
0.2	67	80	80	↑	↑	↑	↑	↑
0.1	80	80	80	80	80	80	80	80

model CLX50-□T		indicates nonusable range						
Air pressure MPa	Allowable eccentricity mm							
	Clamp arm length LH mm							
	38	45	50	60	80	100	120	140
1.0				10	24	37	51	65
0.9			7	16	33	50	67	85
0.8		7	12	23	44	66	87	100
0.7		12	19	33	59	86	100	↑
0.6	8	20	28	45	79	100	↑	↑
0.5	14	30	41	63	100	↑	↑	↑
0.4	24	45	60	90	↑	↑	↑	↑
0.3	41	70	92	100	↑	↑	↑	↑
0.2	74	100	100	↑	↑	↑	↑	↑
0.1	100	100	100	100	100	100	100	100

model CLX63-□T		indicates nonusable range						
Air pressure MPa	Allowable eccentricity mm							
	Clamp arm length LH mm							
	45	50	60	80	100	120	140	160
1.0			4	19	33	48	62	76
0.9			9	27	45	63	81	99
0.8		5	16	38	60	83	105	120
0.7		10	24	52	80	108	120	↑
0.6	9	18	35	71	106	120	↑	↑
0.5	17	28	51	97	120	↑	↑	↑
0.4	29	44	75	120	↑	↑	↑	↑
0.3	48	70	114	↑	↑	↑	↑	↑
0.2	87	120	120	↑	↑	↑	↑	↑
0.1	120	120	120	120	120	120	120	120