

Standard model

model CLX□-□

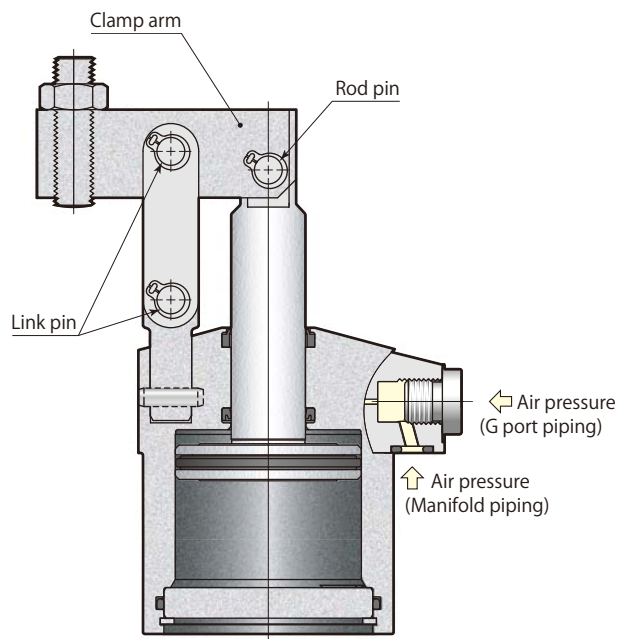

Pneumatic circuit diagram

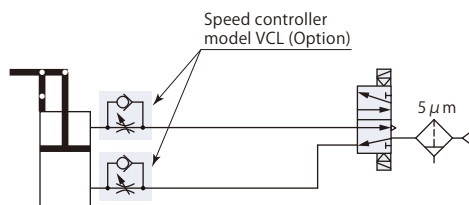

Specifications

Size: 32, 40, 50, 63

CLX

Clamp arm mounting direction: L (Left side), F (Front side), R (Right side)

(Nil) : Standard

E : Dual rod

Model		CLX32	CLX40	CLX50	CLX63	
Cylinder force (air pressure 0.5MPa)	N	400	630	980	1560	
Cylinder inner diameter	mm	32	40	50	63	
Rod diameter	mm	14	16	20	25	
Effective area (clamp)	mm ²	804	1257	1963	3117	
Full stroke	mm	24	26	29.5	34.5	
Clamp stroke	mm	21	23	26.5	31.5	
Safety stroke	mm	3	3	3	3	
Cylinder capacity	Clamp	cm ³	19.3	32.7	57.9	107.5
	Unclamp	cm ³	15.6	27.4	48.7	90.6
Mass	kg	0.39	0.54	0.92	1.44	
Recommended tightening torque of mounting screws*1 N·m		4.0	4.0	5.9	5.9	

- Pressure range: 0.1–1 MPa
 - Proof pressure: 1.5 MPa
 - Operating temperature: 0–70 °C
 - Fluid used: Air*2
 - Oil supply: Not required
 - Seals are resistant to chlorine-based cutting fluid. (not thermal resistant specification)
- *1: ISO R898 class 12.9 *2: Supply the dry and filtered air. Particulate size 5 μm or less is recommended.

When clamping the workpiece, the clamp arm should be situated like the sketch as shown below. (Clamping point)
Please avoid any non-axial force such as the bending moment toward the piston rod. (Allowable angle ±3°)

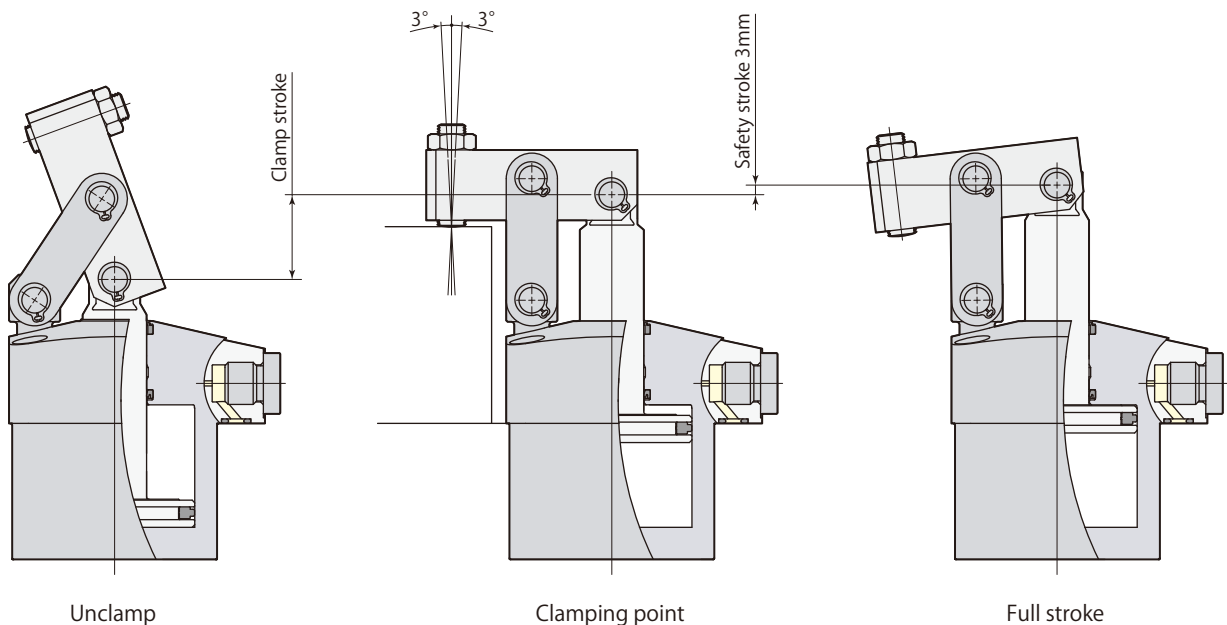

Manifold piping and G port piping are available.

Manifold piping

When choosing manifold piping, a speed controller model VCL is mountable on the G ports of the clamp.

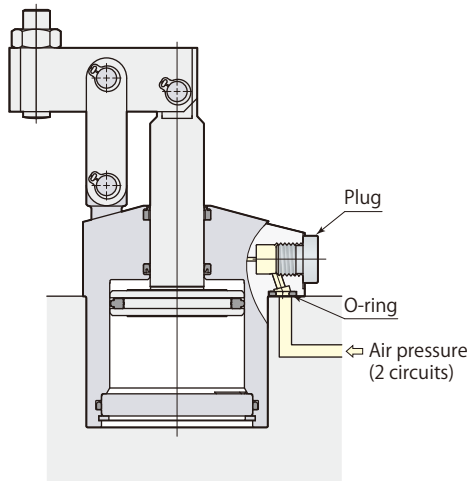

G port piping

When choosing G port piping, remove plugs and mount M3 sealing plugs that are included. (M3 sealing plugs are not mounted at the time of factory shipment.) The one touch fitting or the speed controller with one touch fitting should be mounted when choosing G port piping.

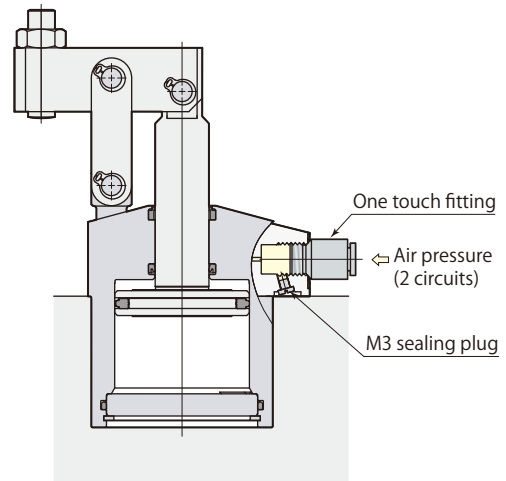

Speed controller model VCL

Page →118

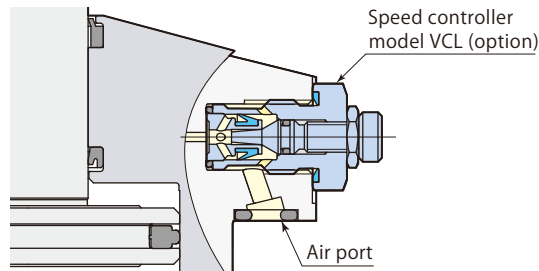

Performance diagram

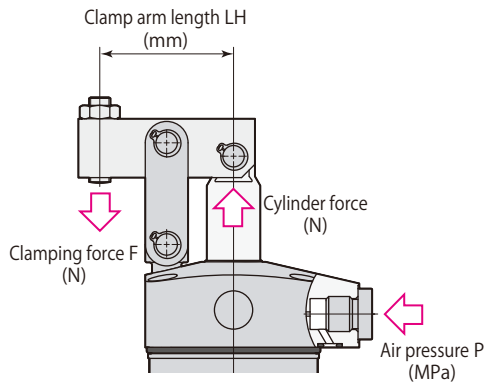

Clamping force varies depending on the clamp arm length (LH) and air pressure (P).

Clamping force calculation formula

$$F = \text{Coefficient 1} \times P \times 1000 / (\text{LH} - \text{Coefficient 2})$$

F: Clamping force P: Air pressure LH: Clamp arm length

CLX50 with clamp arm length (LH) 50 mm at air pressure of 0.5 MPa, Clamping force F is calculated by $44.18 \times 0.5 \times 1000 / (50 - 25.0) = 880 \text{ N}$

Do not use the clamp in the nonusable range. It may cause damage of link mechanism.

model CLX32

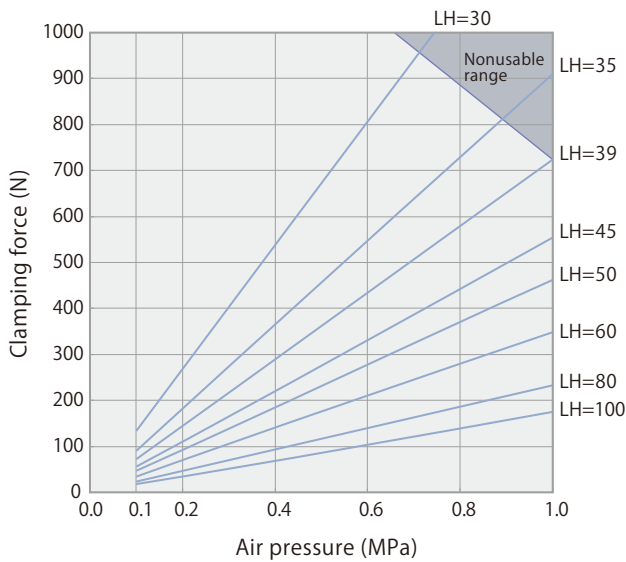

model CLX40

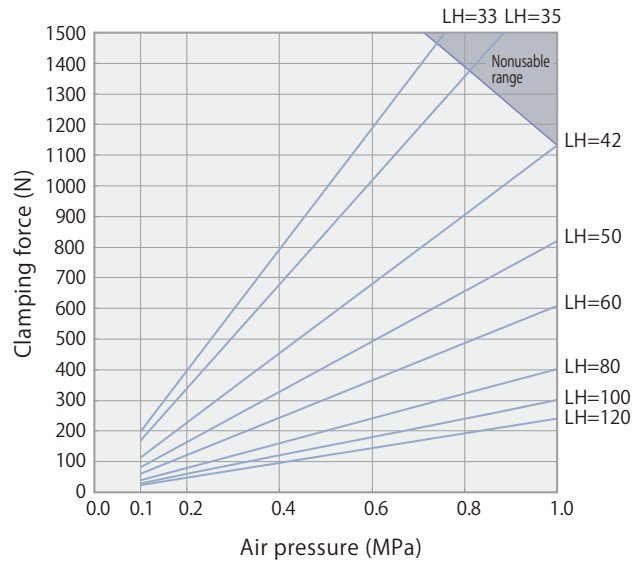

model CLX50

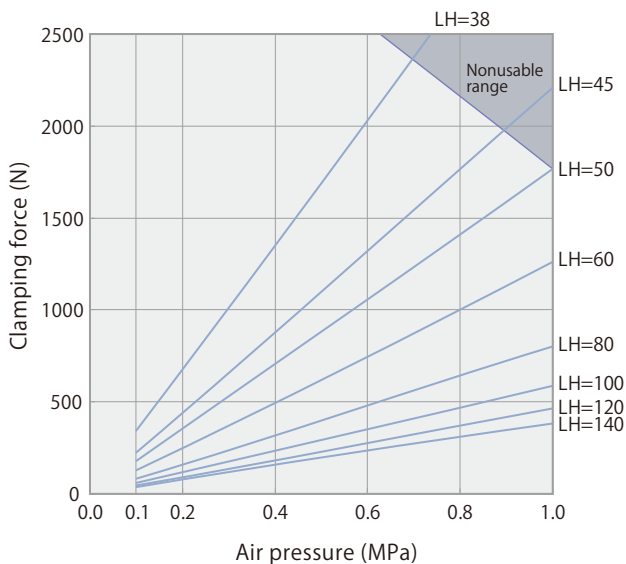

model CLX63

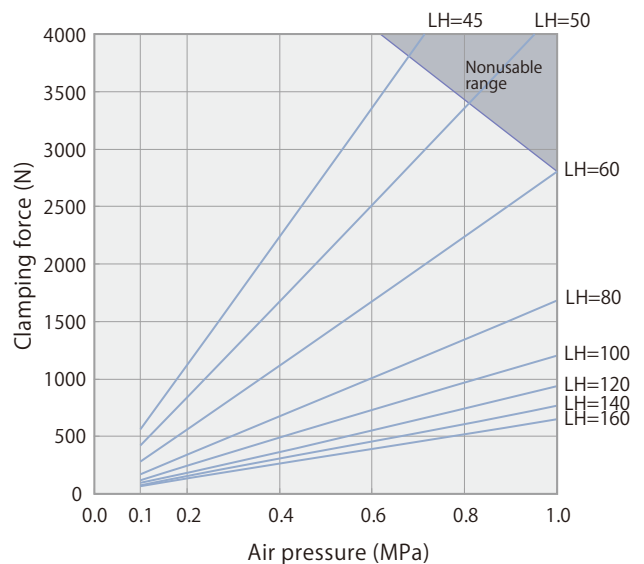

Air link clamp

CLX

Performance table

model CLX32 Clamping force $F=14.11 \times P \times 1000 / (LH-19.5)$

Air pressure MPa	Cylinder force N	Clamping force N								Min. arm length Min. LH mm
		Clamp arm length LH mm								
		30	35	39	45	50	60	80	100	
1.0	800			720	550	460	350	230	180	39
0.9	720			650	500	420	310	210	160	36
0.8	640		730	580	440	370	280	190	140	33
0.7	560	940	640	510	390	320	240	160	120	30
0.6	480	810	550	430	330	280	210	140	110	28
0.5	400	670	460	360	280	230	170	120	90	26
0.4	320	540	360	290	220	190	140	90	70	↑
0.3	240	400	270	220	170	140	100	70	50	↑
0.2	160	270	180	140	110	90	70	50	40	↑
0.1	80	130	90	70	60	50	30	20	20	26

■ indicates nonusable range

model CLX40 Clamping force $F=23.75 \times P \times 1000 / (LH-21.0)$

Air pressure MPa	Cylinder force N	Clamping force N								Min. arm length Min. LH mm
		Clamp arm length LH mm								
		33	35	42	50	60	80	100	120	
1.0	1260			1130	820	610	400	300	240	42
0.9	1130			1020	740	550	360	270	220	38
0.8	1010		1360	900	660	490	320	240	190	35
0.7	880	1390	1190	790	570	430	280	210	170	32
0.6	750	1190	1020	680	490	370	240	180	140	30
0.5	630	990	850	570	410	300	200	150	120	29
0.4	500	790	680	450	330	240	160	120	100	↑
0.3	380	590	510	340	250	180	120	90	70	↑
0.2	250	400	340	230	160	120	80	60	50	↑
0.1	130	200	170	110	80	60	40	30	20	29

■ indicates nonusable range

model CLX50 Clamping force $F=44.18 \times P \times 1000 / (LH-25.0)$

Air pressure MPa	Cylinder force N	Clamping force N								Min. arm length Min. LH mm
		Clamp arm length LH mm								
		38	45	50	60	80	100	120	140	
1.0	1960			1770	1260	800	590	470	380	50
0.9	1770			1590	1140	720	530	420	350	46
0.8	1570		1770	1410	1010	640	470	370	310	42
0.7	1370		1550	1240	880	560	410	330	270	39
0.6	1180	2040	1330	1060	760	480	350	280	230	36
0.5	980	1700	1100	880	630	400	290	230	190	34
0.4	790	1360	880	710	500	320	240	190	150	↑
0.3	590	1020	660	530	380	240	180	140	120	↑
0.2	390	680	440	350	250	160	120	90	80	↑
0.1	200	340	220	180	130	80	60	50	40	34

■ indicates nonusable range

model CLX63 Clamping force $F=84.16 \times P \times 1000 / (LH-30.0)$

Air pressure MPa	Cylinder force N	Clamping force N								Min. arm length Min. LH mm
		Clamp arm length LH mm								
		45	50	60	80	100	120	140	160	
1.0	3120			2810	1680	1200	940	770	650	60
0.9	2810			2520	1510	1080	840	690	580	55
0.8	2490		3370	2240	1350	960	750	610	520	50
0.7	2180		2950	1960	1180	840	650	540	450	46
0.6	1870	3370	2520	1680	1010	720	560	460	390	43
0.5	1560	2810	2100	1400	840	600	470	380	320	40
0.4	1250	2240	1680	1120	670	480	370	310	260	↑
0.3	940	1680	1260	840	500	360	280	230	190	↑
0.2	620	1120	840	560	340	240	190	150	130	↑
0.1	310	560	420	280	170	120	90	80	60	40

■ indicates nonusable range

Dimensions

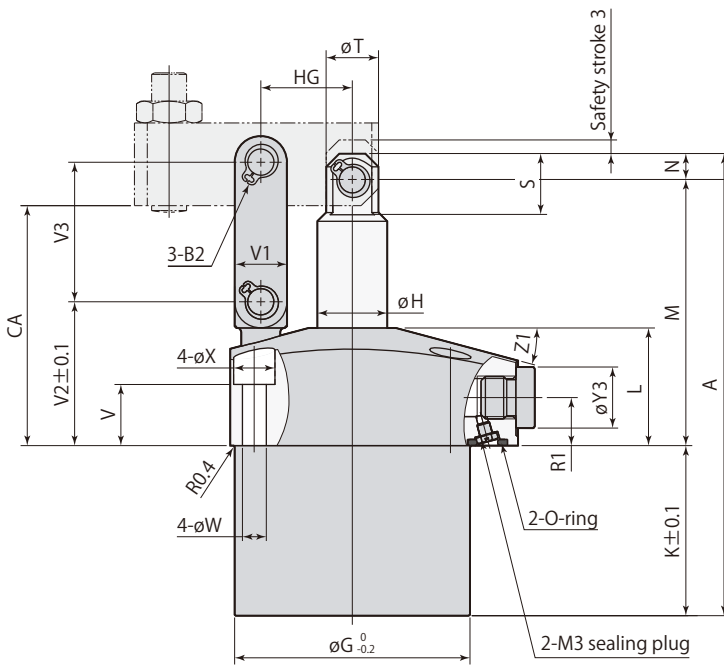
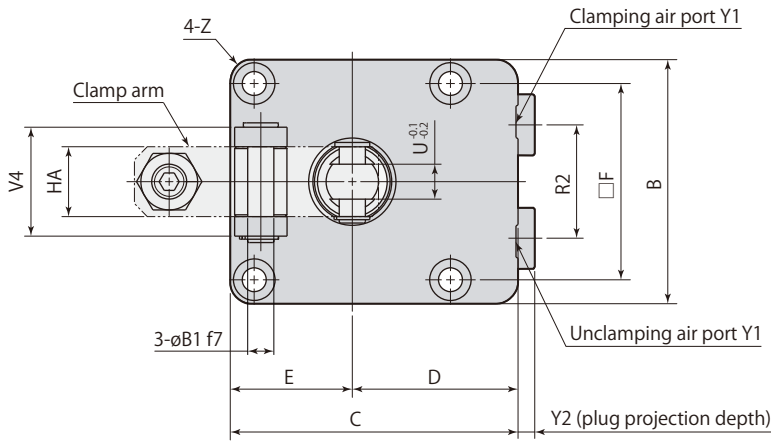

Clamp

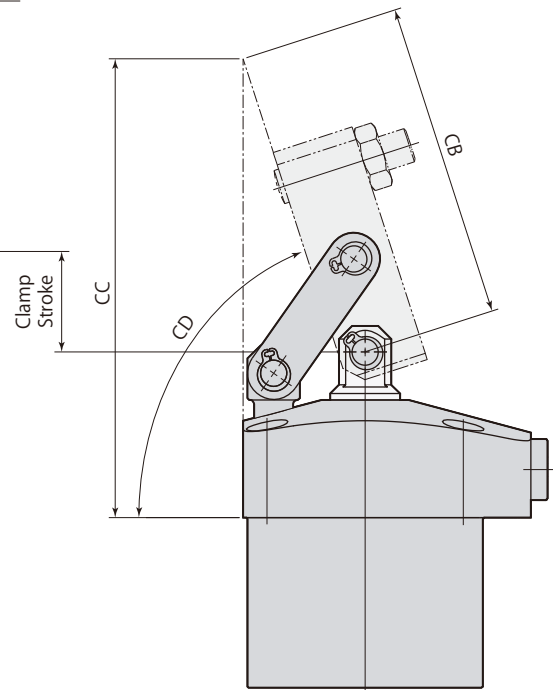

Unclamp

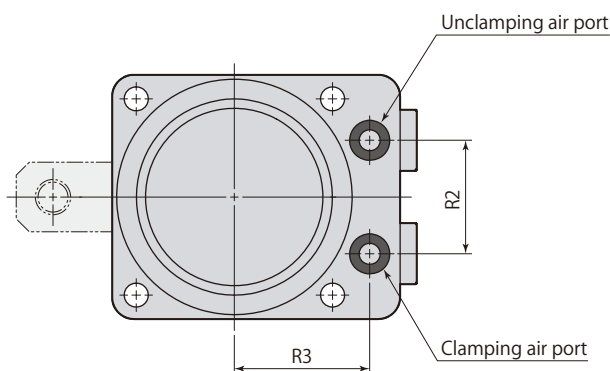

● This diagram represents external contour of CLX □-F, CLX□-L and CLX□-R differ only in terms of mounting direction of clamp arm and otherwise all dimensions are identical to those of CLX□-F.

L: Left side F: Front side R: Right side

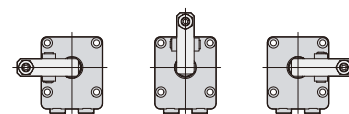

- Clamp arm and mounting screws are not included.
- Install M3 sealing plug when choosing G port piping. The M3 sealing plug is packed with a link clamp.
- Use a snap ring (B2) and a pin (øB1) when installing a clamp arm.

CLX □-□	Air link clamp Standard			air	Double acting
----------------	--------------------------------	--	--	------------	----------------------

mm					
Model	CLX32-□	CLX40-□	CLX50-□	CLX63-□	
A	97	106	122	141.5	
B	50	56	66	78	
C	60	66	80	91	
D	35	38	47	52	
E	25	28	33	39	
F	39	45	53	65	
øG	46	54	64	77	
øH	14	16	20	25	
K	35	39	42.5	53	
L	27	27	32	32	
M	57	61	71.5	78.5	
N	5	6	8	10	
R1	11	11	12.5	12.5	
R2	20	26	30	40	
R3	28	31	36	41	
S	11.5	14	17.5	21.5	
øT	11	12	16	21	
U (width across flats)	7	8	11	13	
V	14	14	17	17	
V1	10	12	16	18	
V2	31.5	33	38.5	39.5	
V3	28.5	32	38	44	
V4	20	25	28	34	
øW	5.5	5.5	6.8	6.8	
øX	9.5	9.5	11	11	
Y1	G1/8	G1/8	G1/4	G1/4	
Y2	3.8	3.8	4.8	4.8	
øY3	14	14	19	19	
Z	R5	R5	R6	R6	
Z1	15°	15°	13°	13°	
B1	5 ^{-0.010} _{-0.022}	6 ^{-0.010} _{-0.022}	8 ^{-0.013} _{-0.028}	10 ^{-0.013} _{-0.028}	
B2 (snap ring)*1	STW-5	STW-6	STW-8	STW-10	
CA	52	55	63.5	69.5	
CB	59	72.5	73.3	82.4	
CC	89.7	105.2	110.9	120.2	
CD	About 70°	About 72°	About 70°	About 68°	
HA	14	16	19	22	
HG	19.5	21	25	30	
O-ring (FKM-90)	P6	P6	P6	P6	
Speed controller*2	Meter-in	VCL01-I	VCL01-I	VCL02-I	VCL02-I
	Meter-out	VCL01-O	VCL01-O	VCL02-O	VCL02-O

*1: Snap ring is made by Ochiai Corporation.

*2: Select the right model of VCL according to the size of the clamp.

● Refer to **page →118** for the details of speed controller.

Mounting details

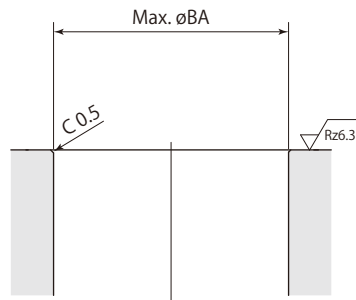
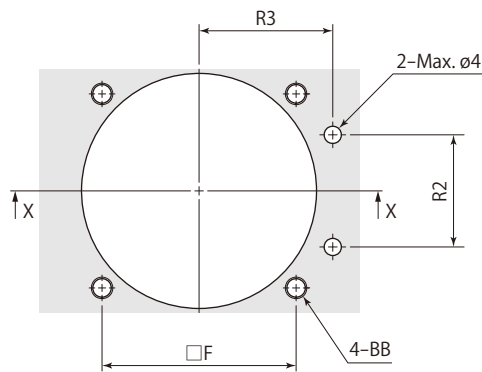

X-X

Rz: ISO4287(1997)

mm

Model	CLX32-□	CLX40-□	CLX50-□	CLX63-□
F	39	45	53	65
R2	20	26	30	40
R3	28	31	36	41
øBA	46.5	54.5	64.5	77.5
BB	M5	M5	M6	M6

Usage example

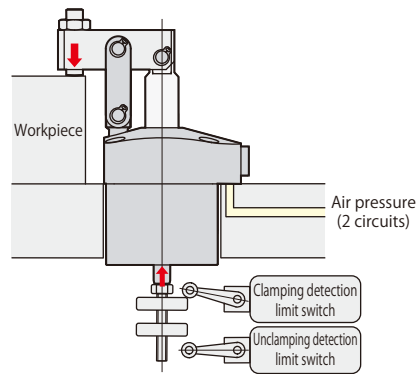

Dimensions

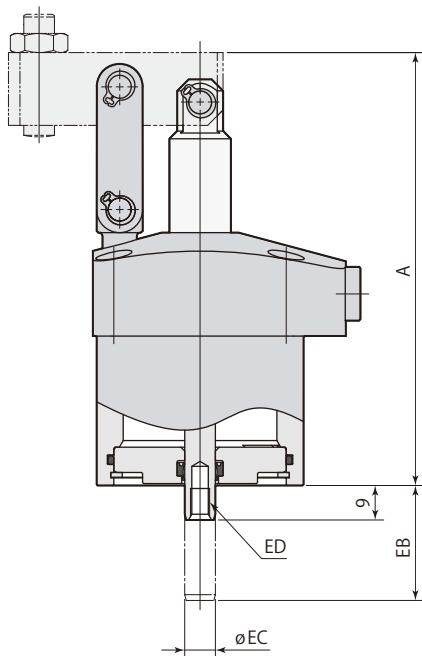

	mm			
Model	CLX32-□E	CLX40-□E	CLX50-□E	CLX63-□E
Effective area (clamp)	754 mm ²	1206 mm ²	1885 mm ²	3039 mm ²
Cylinder capacity (clamp)	18.1 cm ³	31.4 cm ³	55.6 cm ³	104.8 cm ³
A	103	113	128	147.5
EB	30	32	35.5	40.5
øEC	8	8	10	10
ED	M5×0.8 depth 8	M5×0.8 depth 8	M6×1 depth 11	M6×1 depth 11
Mass	0.41 kg	0.56 kg	0.95 kg	1.47 kg

● Refer to specifications (page →84), dimensions (page →88) for specifications and dimensions of products that are not listed on this page.

Clamping performance

Dual rod models have smaller effective area on clamping side, which slightly reduces clamping force.

Obtain clamping force by multiplying standard clamping force obtained from performance diagram (page →86) or performance table (page →87) by coefficient shown in table below.

Calculation example

For models CLX50-FE, with air pressure of 0.5 MPa and clamp arm length of 60 mm :

Clamping force of standard specification CLX50-F : 630 N

Clamping force of CLX50-FE : 630×0.96 = 604.8 N

Model	CLX32-□E	CLX40-□E	CLX50-□E	CLX63-□E
Clamping performance coefficient	0.94	0.96	0.96	0.97

Clamp arm mounting details

Clamp arm is not included. Manufacture a clamp arm with the dimensions shown in the table below.

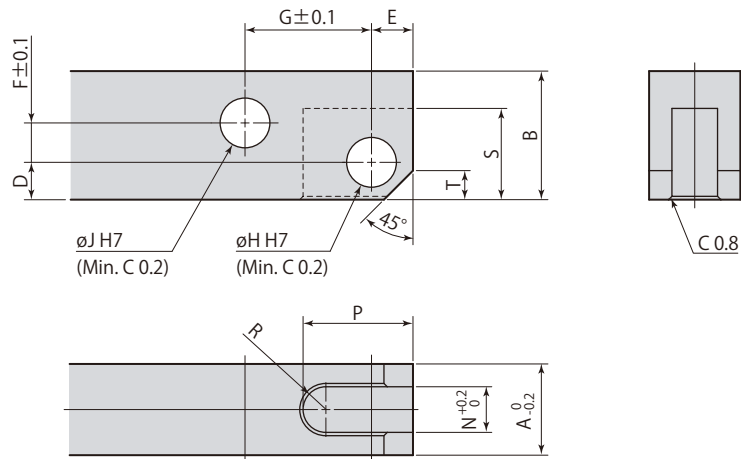

Recommended material: S45C (HB167–229)

Link clamp	CLX32	CLX40	CLX50	CLX63
A	14	16	19	22
B	16	19	22	25
D	5	6	8	9
E	5	6	8	10
F	3	4	5	5
G	19.5	21	25	30
$\varnothing H$	$5^{+0.012}_0$	$6^{+0.012}_0$	$8^{+0.015}_0$	$10^{+0.015}_0$
$\varnothing J$	$5^{+0.012}_0$	$6^{+0.012}_0$	$8^{+0.015}_0$	$10^{+0.015}_0$
N	7	8	11	13
P	16	20	22	27
R	R3.5	R4	R5.5	R6.5
S	12	15	18	22
T	3	4	5	6

● When mounting the clamp arm, use included pins and snap rings.

Clamp arm allowable eccentricity

An eccentric shape clamp arm, as shown in diagram on right can be used with link clamp model CLX, if it is not possible to set clamping point at tip section of clamp arm in alignment with center line of piston rod and clamp arm.

Amount of eccentricity, however, must be within allowable eccentricity shown below.

Using a clamp arm that exceeds allowable eccentricity results in significant eccentric load on link mechanism and piston rod, leading to malfunction.

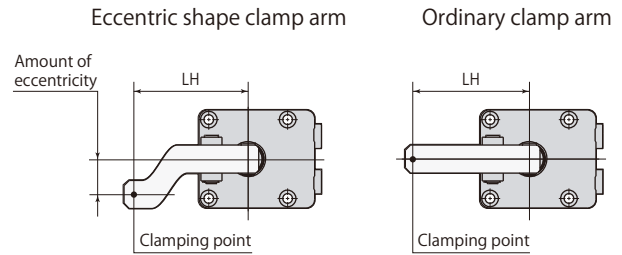

model CLX32		indicates nonusable range						
Air pressure MPa	Allowable eccentricity mm							
	Clamp arm length LH mm							
	30	35	39	45	50	60	80	100
1.0					7	12	24	35
0.9				8	11	18	32	47
0.8			7	12	17	26	44	60
0.7		7	12	18	24	35	58	↑
0.6	5	12	18	26	34	48	60	↑
0.5	9	19	26	38	47	60	↑	↑
0.4	16	29	39	54	60	↑	↑	↑
0.3	28	46	60	60	↑	↑	↑	↑
0.2	51	60	↑	↑	↑	↑	↑	↑
0.1	60	60	60	60	60	60	60	60

model CLX40		indicates nonusable range						
Air pressure MPa	Allowable eccentricity mm							
	Clamp arm length LH mm							
	33	35	42	50	60	80	100	120
1.0				6	13	26	39	53
0.9				5	11	20	36	53
0.8				9	17	28	49	70
0.7		3	6	15	25	39	65	80
0.6	7	11	23	36	53	80	↑	↑
0.5	14	18	33	51	73	↑	↑	↑
0.4	23	29	50	73	80	↑	↑	↑
0.3	38	47	77	80	↑	↑	↑	↑
0.2	67	80	80	↑	↑	↑	↑	↑
0.1	80	80	80	80	80	80	80	80

model CLX50		indicates nonusable range						
Air pressure MPa	Allowable eccentricity mm							
	Clamp arm length LH mm							
	38	45	50	60	80	100	120	140
1.0				10	24	37	51	65
0.9			7	16	33	50	67	85
0.8		7	12	23	44	66	87	100
0.7		12	19	33	59	86	100	↑
0.6	8	20	28	45	79	100	↑	↑
0.5	14	30	41	63	100	↑	↑	↑
0.4	24	45	60	90	↑	↑	↑	↑
0.3	41	70	92	100	↑	↑	↑	↑
0.2	74	100	100	↑	↑	↑	↑	↑
0.1	100	100	100	100	100	100	100	100

model CLX63		indicates nonusable range						
Air pressure MPa	Allowable eccentricity mm							
	Clamp arm length LH mm							
	45	50	60	80	100	120	140	160
1.0			4	19	33	48	62	76
0.9			9	27	45	63	81	99
0.8		5	16	38	60	83	105	120
0.7		10	24	52	80	108	120	↑
0.6	9	18	35	71	106	120	↑	↑
0.5	17	28	51	97	120	↑	↑	↑
0.4	29	44	75	120	↑	↑	↑	↑
0.3	48	70	114	↑	↑	↑	↑	↑
0.2	87	120	120	↑	↑	↑	↑	↑
0.1	120	120	120	120	120	120	120	120