

Swing clamp

Single acting 7 MPa

model **CTN**



Single acting Swing clamp
model CTN06-L

Compact model

model **CTN**□-□ JP PAT.

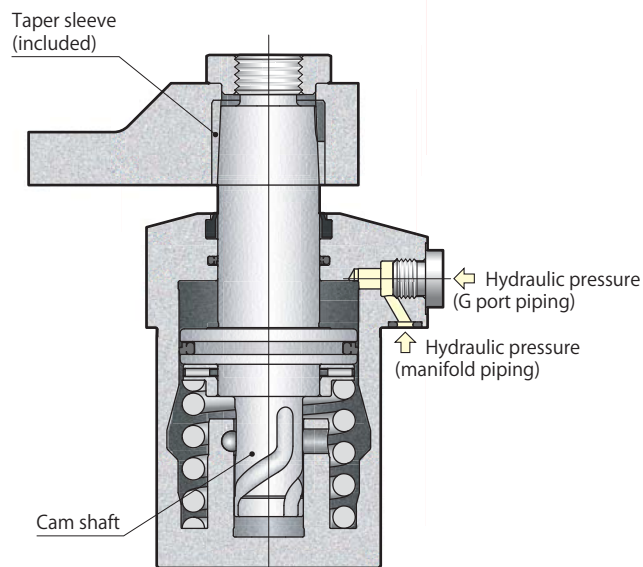

Hydraulic circuit diagram

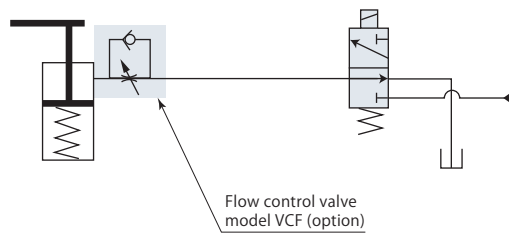



Use flow control valve for meter-in control.

Specifications page → 85

Dimensions page → 88

Mounting details page → 90

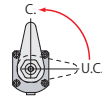
Specifications

	Size	Swing direction (when clamping)
CTN	02	L : Counter-clockwise  R : Clockwise 
	04	
	05	
	06	
	10	
	16	

Contact Pascal for the details of variation codes (models) that are not described in the catalog.

Model		CTN02	CTN04	CTN05	CTN06	CTN10	CTN16	
Cylinder force (hydraulic pressure 7MPa)*1	kN	2.3	3.3	4.4	5.8	8.1	12.1	
Cylinder inner diameter	mm	27	32	38	44	52	63	
Rod diameter	mm	15	18	22	25	30	35.5	
Effective area (clamp)	cm ²	4.0	5.5	7.5	10.3	14.2	21.3	
Swing angle		90° ± 3°						
Positioning pin groove position accuracy		± 1°						
Repeated clamp positioning accuracy		± 0.5°						
Full stroke	mm	12.5	13	14	16.5	18	21.5	
90° swing stroke	mm	4.5	5	6	6.5	8	9.5	
Clamp stroke	mm	8	8	8	10	10	12	
Cylinder capacity (clamp)	cm ³	4.9	7.1	10.6	17.0	25.5	45.7	
Return spring force	Unclamp	kN	0.35	0.42	0.59	0.82	1.03	1.54
	Clamp stroke central position	kN	0.45	0.54	0.85	1.38	1.82	2.80
	Clamp end	kN	0.50	0.60	0.95	1.63	2.13	3.29
Recommended piping inner diameter*2	mm	ø6	ø6	ø6	ø6	ø8	ø8	
Mass	kg	0.6	0.8	1.2	1.7	2.5	3.8	
Recommended tightening torque of mounting screws*3	N·m	3.5	7	7	12	12	29	
Recommended tightening torque of nut	N·m	7.5	14	40	50	74	116	

- Pressure range: 2.5–7 MPa
- Proof pressure: 10.5 MPa
- Operating temperature: 0–70 °C
- Fluid used: General mineral based hydraulic oil (ISO-VG32 equivalent)
- Seals are resistant to chlorine-based cutting fluid. (not thermal resistant specification)

*1: This is value for central position of clamp stroke.

*2: Care must be taken when numerous clamps are used or when hydraulic piping is long. *3: ISO R898 class 12.9

Manifold piping and G port piping are available.Manifold piping

When choosing manifold piping, a flow control valve (model VCF) and an air bleeding valve (model VCE) are mountable on the G ports of the clamp.

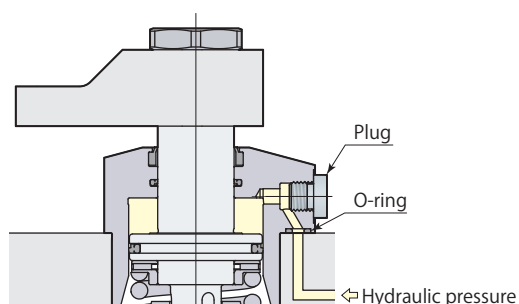
G port piping

Remove plug when choosing G port piping. (O-ring must be used.) Refer to **page →220** for details on G port piping flareless fitting. The flow control valve and the air bleeding valve should be installed in the middle of oil path.

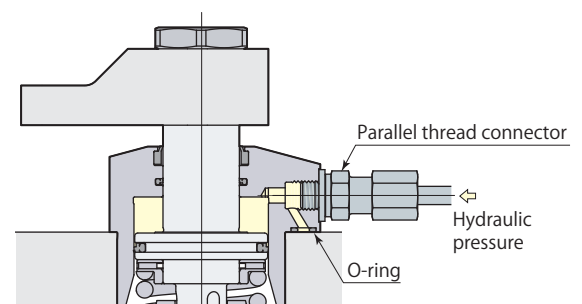

Performance table

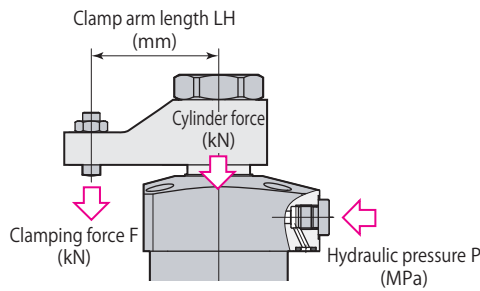

Clamping force varies depending on the clamp arm length (LH) and hydraulic pressure (P).

Clamping force calculation formula

$$F = (P - \text{Coefficient } 1) / (\text{Coefficient } 2 + \text{Coefficient } 3 \times LH)$$

F: Clamping force P: Hydraulic pressure LH: Clamp arm length

CTN06 with clamp arm length (LH) = 50 mm at hydraulic pressure of 7 MPa, Clamping force F is calculated by $(7 - 1.34) / (0.971 + 0.00444 \times 50) = 4.7 \text{ kN}$

Do not use the clamp in the nonusable range. It may cause damage to the cylinder and rod.

model CTN02		Clamping force $F = (P - 1.15) / (2.53 + 0.014 \times LH)$								Max. arm length Max. LH mm
Hydraulic pressure MPa	Cylinder force kN	Clamping force kN								
		Clamp arm length LH mm								
7	2.3	2.0	3.0	4.0	5.0	6.0	8.0	10.0	12.0	53
6.5	2.1	1.9	1.8	1.7	1.7	1.6	Nonusable range			60
6	1.9	1.7	1.6	1.6	1.5	1.4	Nonusable range			69
5.5	1.7	1.5	1.5	1.4	1.3	1.3	1.2			81
5	1.5	1.3	1.3	1.2	1.2	1.1	1.1			98
4.5	1.3	1.2	1.1	1.1	1.0	1.0	0.9	0.9	0.8	123
4	1.1	1.0	1.0	0.9	0.9	0.8	0.8	0.7	0.7	↑
3.5	0.9	0.8	0.8	0.8	0.7	0.7	0.6	0.6	0.6	↑
3	0.7	0.6	0.6	0.6	0.6	0.5	0.5	0.5	0.4	↑
2.5	0.5	0.5	0.5	0.4	0.4	0.4	0.4	0.3	0.3	123

model CTN04		Clamping force $F = (P - 0.986) / (1.82 + 0.00974 \times LH)$									Max. arm length Max. LH mm
Hydraulic pressure MPa	Cylinder force kN	Clamping force kN									
		Clamp arm length LH mm									
7	3.3	2.7	2.6	2.5	Nonusable range						68
6.5	3.0	2.5	2.4	2.3	2.2	Nonusable range				77	
6	2.8	2.3	2.2	2.1	2.0	1.9	Nonusable range			89	
5.5	2.5	2.0	2.0	1.9	1.8	1.7	1.6			104	
5	2.2	1.8	1.7	1.7	1.6	1.5	1.4	1.3	1.1	127	
4.5	1.9	1.6	1.5	1.5	1.4	1.4	1.3	1.2	1.1	162	
4	1.7	1.4	1.3	1.3	1.2	1.2	1.1	1.0	0.9	↑	
3.5	1.4	1.1	1.1	1.0	1.0	0.9	0.8	0.8	0.8	↑	
3	1.1	0.9	0.9	0.8	0.8	0.8	0.7	0.7	0.6	↑	
2.5	0.8	0.7	0.7	0.6	0.6	0.6	0.5	0.5	0.5	162	

model CTN05		Clamping force $F = (P - 1.12) / (1.33 + 0.00663 \times LH)$									Max. arm length Max. LH mm
Hydraulic pressure MPa	Cylinder force kN	Clamping force kN									
		Clamp arm length LH mm									
7	4.4	3.5	3.4	3.2	Nonusable range						84
6.5	4.0	3.2	3.1	2.9	Nonusable range						96
6	3.7	2.9	2.8	2.6	2.4	Nonusable range				111	
5.5	3.3	2.6	2.5	2.4	2.2	2.1				133	
5	2.9	2.3	2.2	2.1	1.9	1.8	1.7	1.6			164
4.5	2.5	2.0	2.0	1.8	1.7	1.6	1.5	1.4	1.3	214	
4	2.2	1.7	1.7	1.5	1.4	1.4	1.3	1.2	1.1	↑	
3.5	1.8	1.4	1.4	1.3	1.2	1.1	1.1	1.0	0.9	↑	
3	1.4	1.1	1.1	1.0	0.9	0.9	0.8	0.8	0.7	↑	
2.5	1.0	0.8	0.8	0.7	0.7	0.6	0.6	0.6	0.5	214	

model CTN06		Clamping force $F = (P - 1.34) / (0.971 + 0.00444 \times LH)$									Max. arm length Max. LH mm
Hydraulic pressure MPa	Cylinder force kN	Clamping force kN									
		Clamp arm length LH mm									
7	5.8	4.7	4.6	Nonusable range						69	
6.5	5.3	4.3	4.2	Nonusable range						78	
6	4.8	3.9	3.8	3.5	Nonusable range				90		
5.5	4.3	3.5	3.4	3.1	2.9					106	
5	3.8	3.1	3.0	2.8	2.6	2.4				128	
4.5	3.3	2.6	2.6	2.4	2.2	2.1	2.0	1.9			164
4	2.7	2.2	2.1	2.0	1.9	1.8	1.7	1.6	1.5	227	
3.5	2.2	1.8	1.7	1.6	1.5	1.4	1.4	1.3	1.2	↑	
3	1.7	1.4	1.3	1.3	1.2	1.1	1.0	1.0	0.9	↑	
2.5	1.2	1.0	0.9	0.9	0.8	0.8	0.7	0.7	0.7	227	

model CTN10		Clamping force $F = (P - 1.29) / (0.706 + 0.00298 \times LH)$									Max. arm length Max. LH mm	
Hydraulic pressure MPa	Cylinder force kN	Clamping force kN										
		Clamp arm length LH mm										
7	8.1	6.5	6.0	Nonusable range								86
6.5	7.4	5.9	5.5	Nonusable range								97
6	6.7	5.3	5.0	4.7	Nonusable range						112	
5.5	6.0	4.8	4.5	4.2	4.0					133		
5	5.3	4.2	3.9	3.7	3.5	3.3	3.1			163		
4.5	4.5	3.6	3.4	3.2	3.0	2.9	2.7	2.6	2.5	212		
4	3.8	3.1	2.9	2.7	2.5	2.4	2.3	2.2	2.1	↑		
3.5	3.1	2.5	2.3	2.2	2.1	2.0	1.9	1.8	1.7	↑		
3	2.4	1.9	1.8	1.7	1.6	1.5	1.4	1.4	1.3	↑		
2.5	1.7	1.4	1.3	1.2	1.1	1.1	1.0	1.0	0.9	212		

model CTN16		Clamping force $F = (P - 1.32) / (0.47 + 0.00171 \times LH)$									Max. arm length Max. LH mm
Hydraulic pressure MPa	Cylinder force kN	Clamping force kN									
		Clamp arm length LH mm									
7	12.1	9.9	9.4	8.9	Nonusable range						102
6.5	11.0	9.0	8.5	8.1	Nonusable range						116
6	10.0	8.2	7.7	7.3	6.9	Nonusable range				134	
5.5	8.9	7.3	6.9	6.5	6.2	5.9				159	
5	7.8	6.4	6.1	5.7	5.5	5.2	4.9	4.7			197
4.5	6.8	5.6	5.2	5.0	4.7	4.5	4.3	4.1	3.9	256	
4	5.7	4.7	4.4	4.2	4.0	3.8	3.6	3.4	3.3	↑	
3.5	4.6	3.8	3.6	3.4	3.2	3.1	2.9	2.8	2.7	↑	
3	3.6	2.9	2.8	2.6	2.5	2.4	2.3	2.2	2.1	↑	
2.5	2.5	2.1	1.9	1.8	1.7	1.7	1.6	1.5	1.5	256	

Swing speed adjustment

Swing time is restricted by the mass and length of the clamp arm (moment of inertia) since the 90° swing action impacts the cam shaft.

1. Calculate the moment of inertia according to the arm length and mass.
 2. Adjust swing speed with flow control valve to ensure that 90° swing time of the clamp arm is greater than the shortest swing time in the graph shown below.
- The cam groove may be damaged in case the swing speed is set at the nonusable range in the graph.

Example of calculation for moment of inertia

$$I = \frac{1}{12} m_1(4A_1^2 + B^2) + \frac{1}{12} m_2(4A_2^2 + B^2)$$

I : Moment of inertia (kg·m²)
m : Mass (kg)

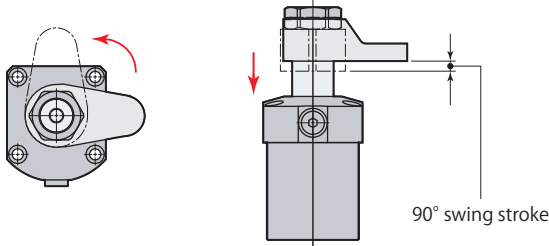
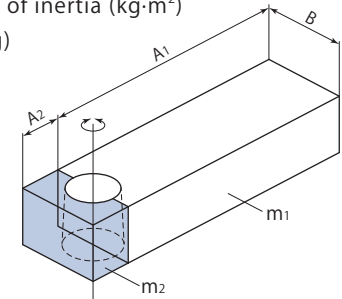

model CTN02

Shortest swing time calculation formula $t = \sqrt{\frac{I}{0.0134}}$

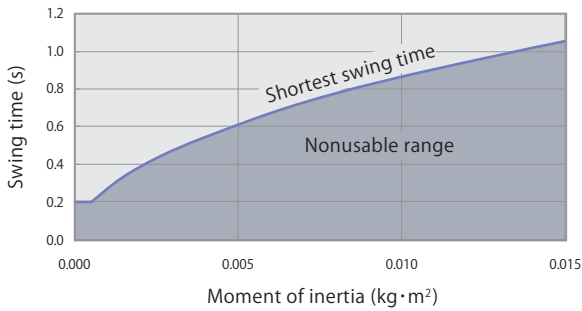

model CTN04

Shortest swing time calculation formula $t = \sqrt{\frac{I}{0.0153}}$

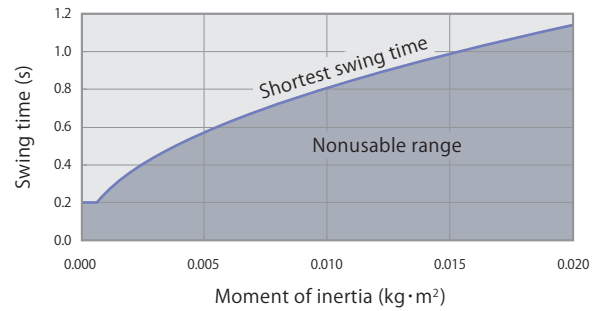

model CTN05

Shortest swing time calculation formula $t = \sqrt{\frac{I}{0.0190}}$

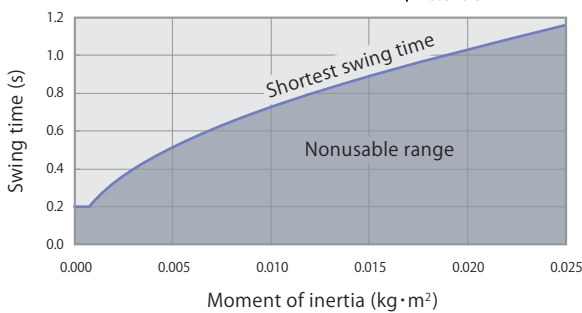

model CTN06

Shortest swing time calculation formula $t = \sqrt{\frac{I}{0.0378}}$

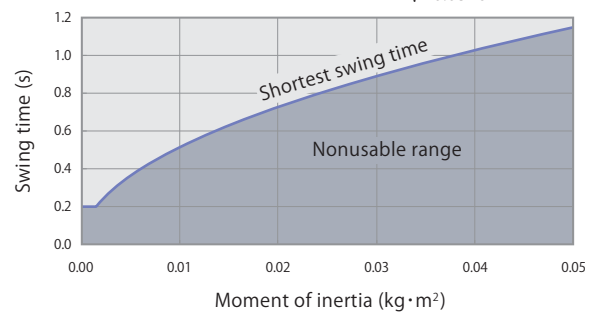

model CTN10

Shortest swing time calculation formula $t = \sqrt{\frac{I}{0.0450}}$

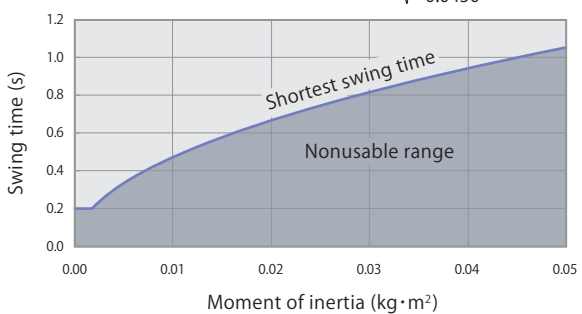

model CTN16

Shortest swing time calculation formula $t = \sqrt{\frac{I}{0.0905}}$

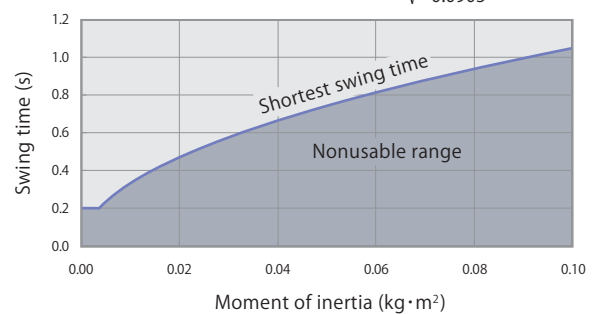

Dimensions

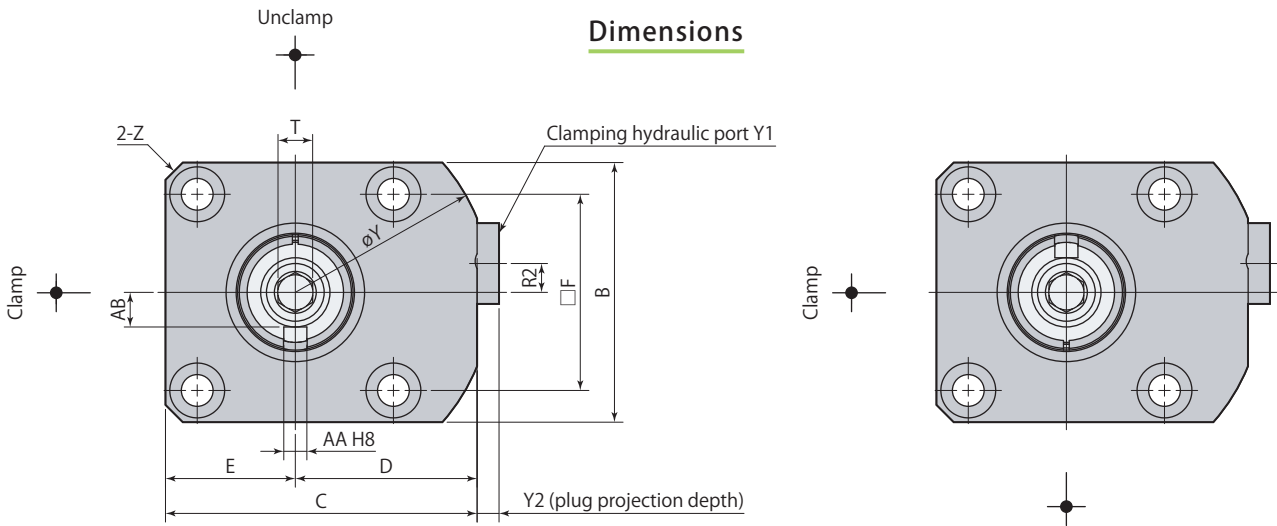

Swing direction L (counter-clockwise)

Swing direction R (clockwise)

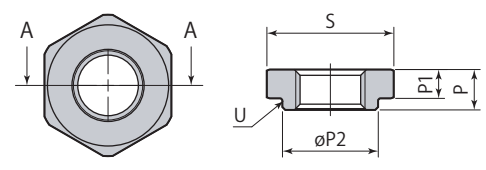
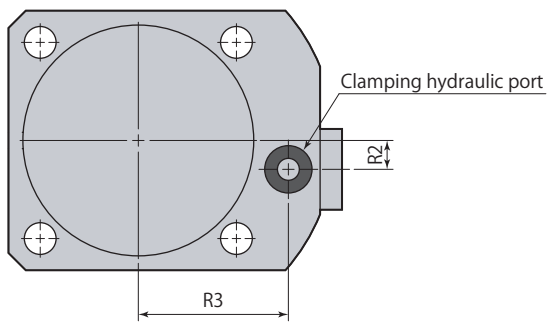
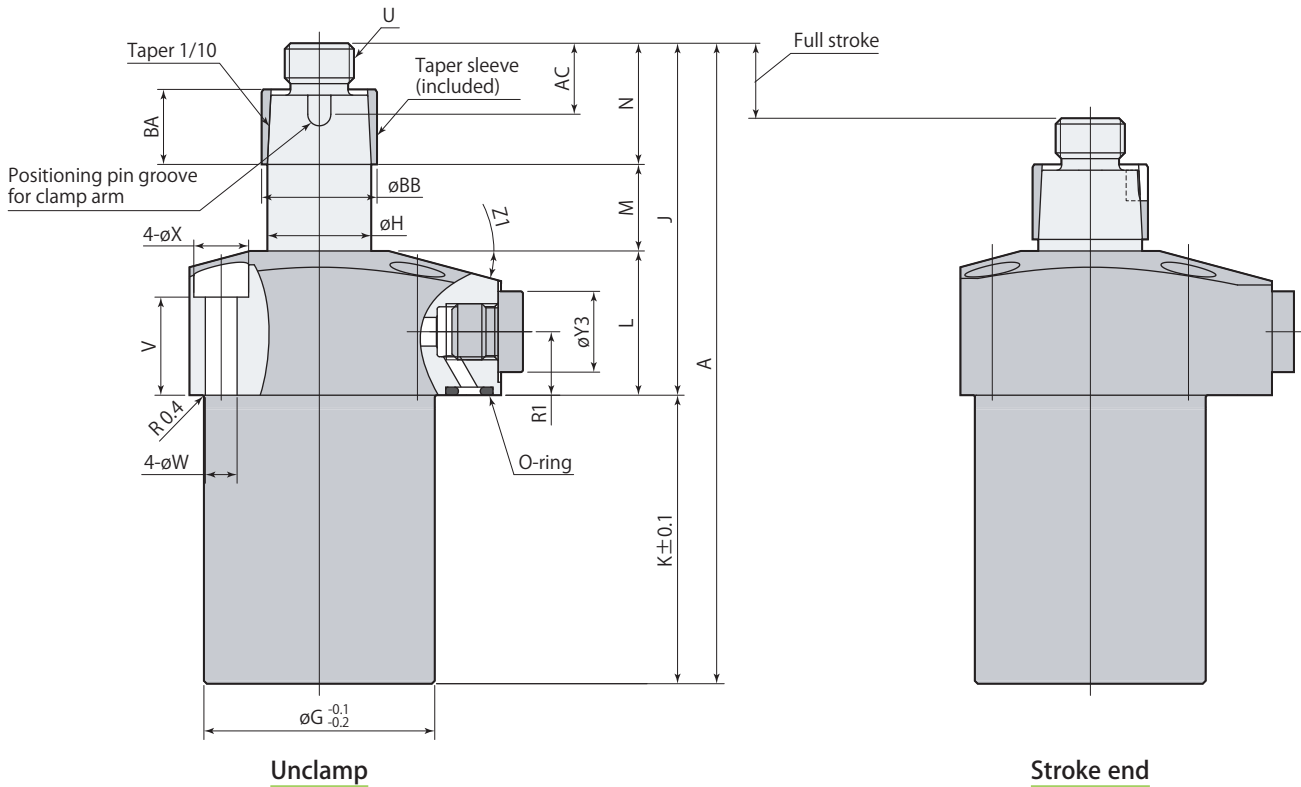

Hex nut for arm mount

A-A

- Hex nut for arm mount, taper sleeve are included.
- Clamp arm, positioning pin and mounting screws are not included.

CTN □-□	Single acting Swing clamp					7MPa	Single acting
----------------	----------------------------------	--	--	--	--	-------------	----------------------

Model		CTN02-□	CTN04-□	CTN05-□	CTN06-□	CTN10-□	CTN16-□
A		103.5	111	121	137.5	145	171.5
B		40	45	51	60	70	80
C		49	54	61	69	81	92
D		29	31.5	35.5	39	46	52
E		20	22.5	25.5	30	35	40
F		31.4	34	40	47	55	63
øG		36	40	48	55	65	75
øH		15	18	22	25	30	35.5
J		55.5	61	69	78.5	82	100.5
K		48	50	52	59	63	71
L		25	25	28	28	30	37
M		14.5	15	16	18.5	20	23.5
N		16	21	25	32	32	40
P		5.8	7	9	10	10	12
P1		4	5	6	7	7	8
øP2		13.8	16.6	20.5	22.9	27.9	32.8
R1		11	11	13	12	14.5	18
R2	G port position	5	5	0	0	15	16
	Manifold port position					0	0
R3		23.5	26	30	33.5	39.5	45
S (nut width across flats)		19	22	24	30	36	41
T (hex socket)		5	6	8	8	10	10
U		M10×1	M12×1.5	M16×1.5	M18×1.5	M22×1.5	M28×1.5
V		18	17	18.5	17	18	22
øW		4.5	5.5	5.5	6.8	6.8	9
øX		7.5	9.5	9.5	11	11	14
øY		63	68	73	80	106	116
Y1		G1/8	G1/8	G1/8	G1/8	G1/4	G1/4
Y2		3.8	3.8	3.8	3.8	4.8	4.8
øY3		14	14	14	14	19	19
Z		C2	C3	C3	(ø80)	C4	C5
Z1		15°	15°	15°	15°	12°	12°
O-ring (fluorocarbon hardness Hs90)		P5	P5	P5	P5	P7	P7
AA		3 ^{+0.018} ₀	4 ^{+0.018} ₀	4 ^{+0.018} ₀	4 ^{+0.018} ₀	6 ^{+0.018} ₀	6 ^{+0.018} ₀
AB		5	6	8	9	11	14
AC		9.5	12.3	14.3	15.3	16.5	18.5
BA		9.5	13	15	21	21	27
øBB		17	20	25	28	34	40
Flow control valve (meter-in)*		VCF01S	VCF01S	VCF01S	VCF01S	VCF02	VCF02
Air bleeding valve*		VCE01	VCE01	VCE01	VCE01	VCE02	VCE02

*: Select the right model of VCF and VCE according to the size of the clamp.

Refer to each page for the details of options.

● Flow control valve **page →94** ● Air bleeding valve **page →96**

Mounting details

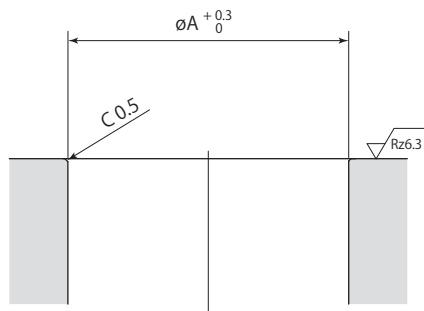
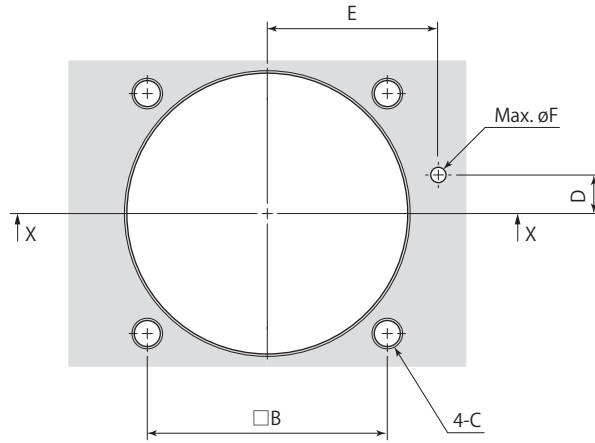

X-X

Rz: ISO4287(1997)

mm

Model	CTN02-□	CTN04-□	CTN05-□	CTN06-□	CTN10-□	CTN16-□
øA	36	40	48	55	65	75
B	31.4	34	40	47	55	63
C	M4	M5	M5	M6	M6	M8
D	5	5	0	0	0	0
E	23.5	26	30	33.5	39.5	45
øF	3	3	3	3	5	5

Clamp arm mounting details

(Using taper sleeve)

Clamp arm is not included. Manufacture a clamp arm with the dimensions shown in the table below.

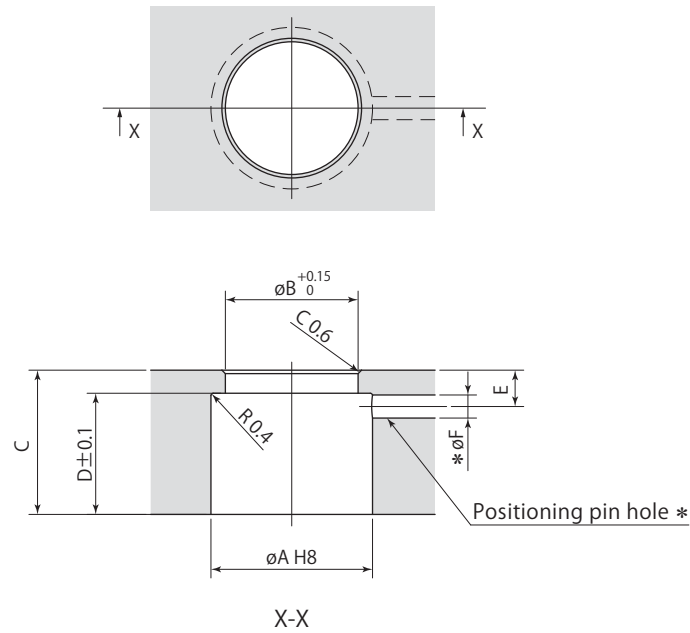

*:No need to machine the pin hole ($\varnothing F$) unless positioning pin is used for the arm.
The positioning pin enables a clamp arm to locate on the clamp firmly and easily.

Swing clamp	CTN02	CTN04	CTN05	CTN06	CTN10	CTN16
$\varnothing A$	17 ^{+0.027} ₀	20 ^{+0.033} ₀	25 ^{+0.033} ₀	28 ^{+0.033} ₀	34 ^{+0.039} ₀	40 ^{+0.039} ₀
$\varnothing B$	13.9	16.7	20.6	23	28	32.9
C	12	16	19	25	25	32
D	9.5	13	15	21	21	27
E	4.3	5.3	6.3	6.3	7.5	8.5
$\varnothing F$ (pin hole diameter)	3	4	4	4	6	6

mm