

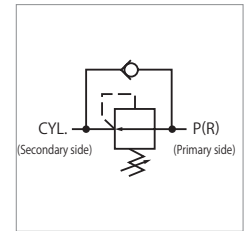

Reducing valve model VRG

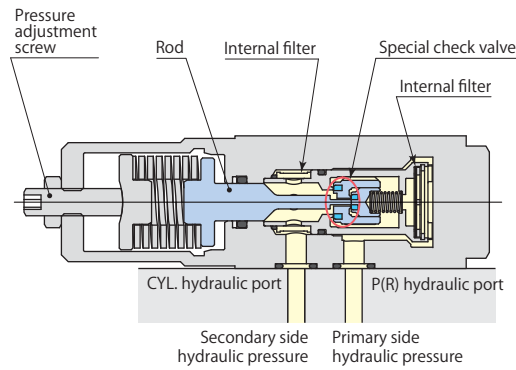

Internal hydraulic pressure of circuit can be partially reduced. This is a non-leak type that requires no drain.

Specifications

Model	VRG-LG	VRG-LT	VRG-LS
Mounting, piping methods	Manifold mounting	Piping mounting	VHD linking
Primary side hydraulic pressure range	MPa	2-7	
Secondary side hydraulic pressure range	MPa	1-6	
Allowable min. differential pressure*	MPa	1	
Proof pressure	MPa	10.5	
Pressure change per revolution	MPa/rev	0.5	
Orifice area	mm ²	28.1	
Operating temperature	°C	0-70	
Fluid used	General mineral based hydraulic oil (ISO-VG32 equivalent)		
Mass	kg	0.9	1.0

- Fluorocarbon has been adopted for seal sections where cutting fluid is applied, as a measure for the use of chlorine-based cutting fluid (this is not thermal resistant specification).
 - Avoid overpressure to CYL. hydraulic port of the valve if there is a risk of back pressure in secondary circuit.
- *: The setting should be performed so that the differential pressure between primary side hydraulic pressure and secondary side hydraulic pressure may exceed 1 MPa. (Example: If primary side hydraulic pressure is 5 MPa, secondary side hydraulic pressure should be from 1 to 4 MPa.)

■ indicates made to order.

Dimensions

VRG-LG Manifold mounting *With internal filter (P & CYL. hydraulic ports)

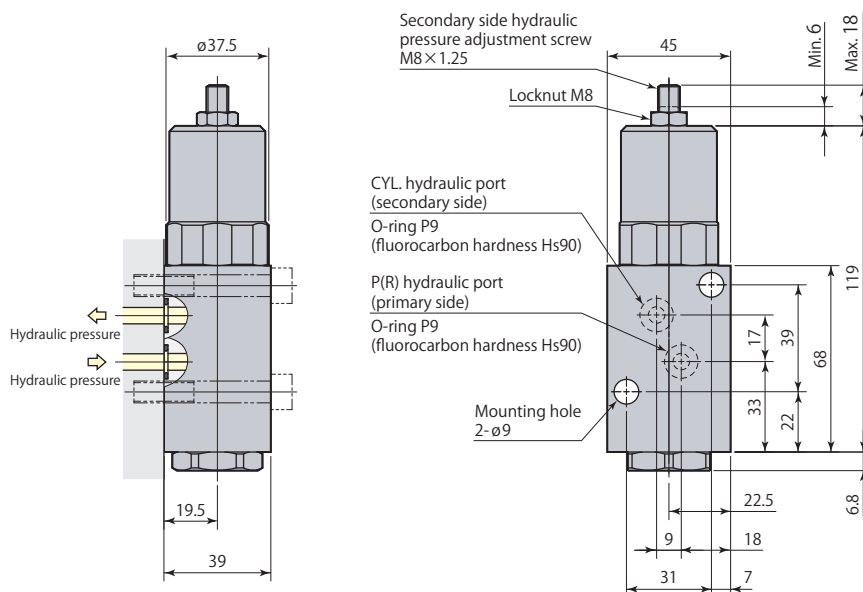

Mounting details

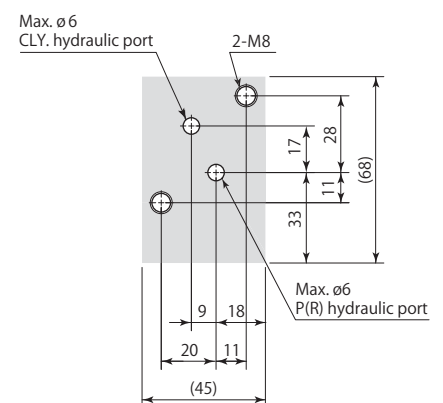

For manifold piping, the mounting surface finish must be no rougher than Rz6.3 (ISO4287:1997).

Dimensions

VRG-LT Piping mounting *With internal filter (P & CYL. hydraulic ports)

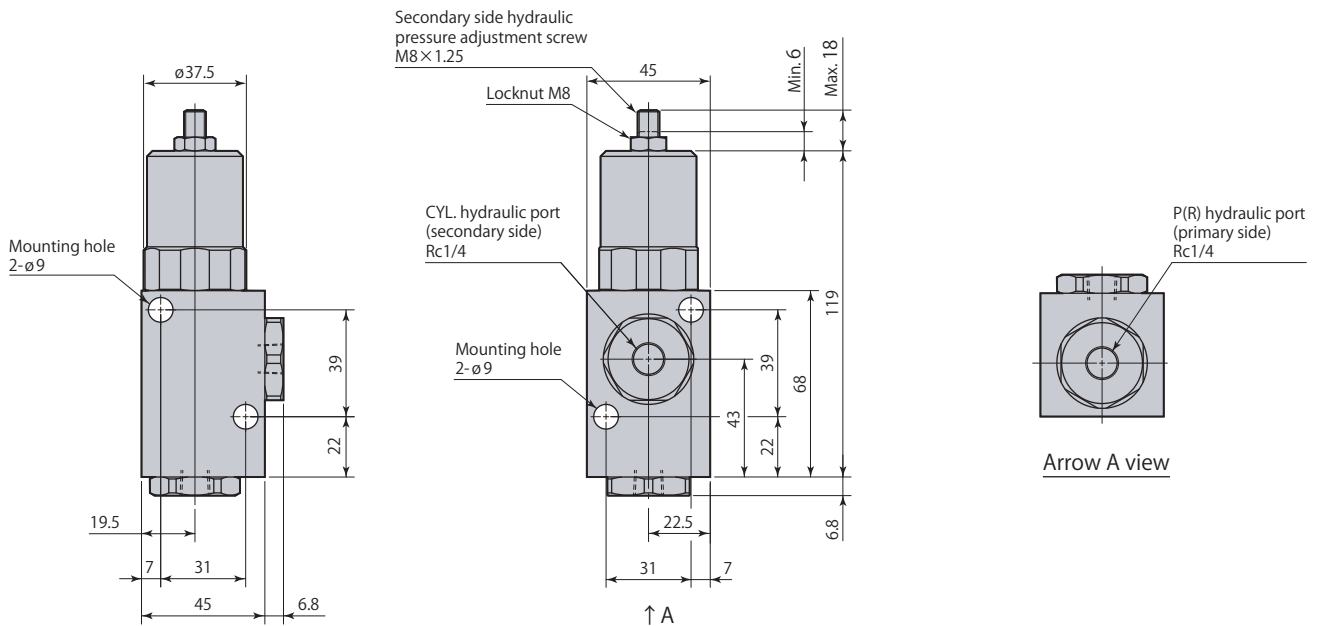

VRG-LS VHD linking *With internal filter (P & CYL. hydraulic ports)

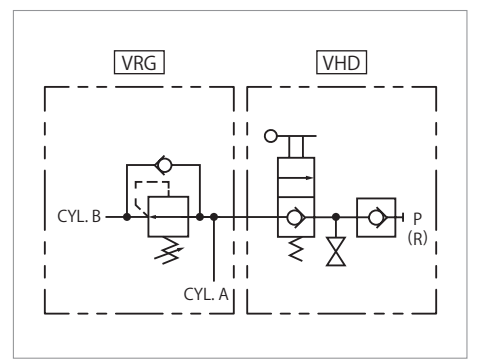
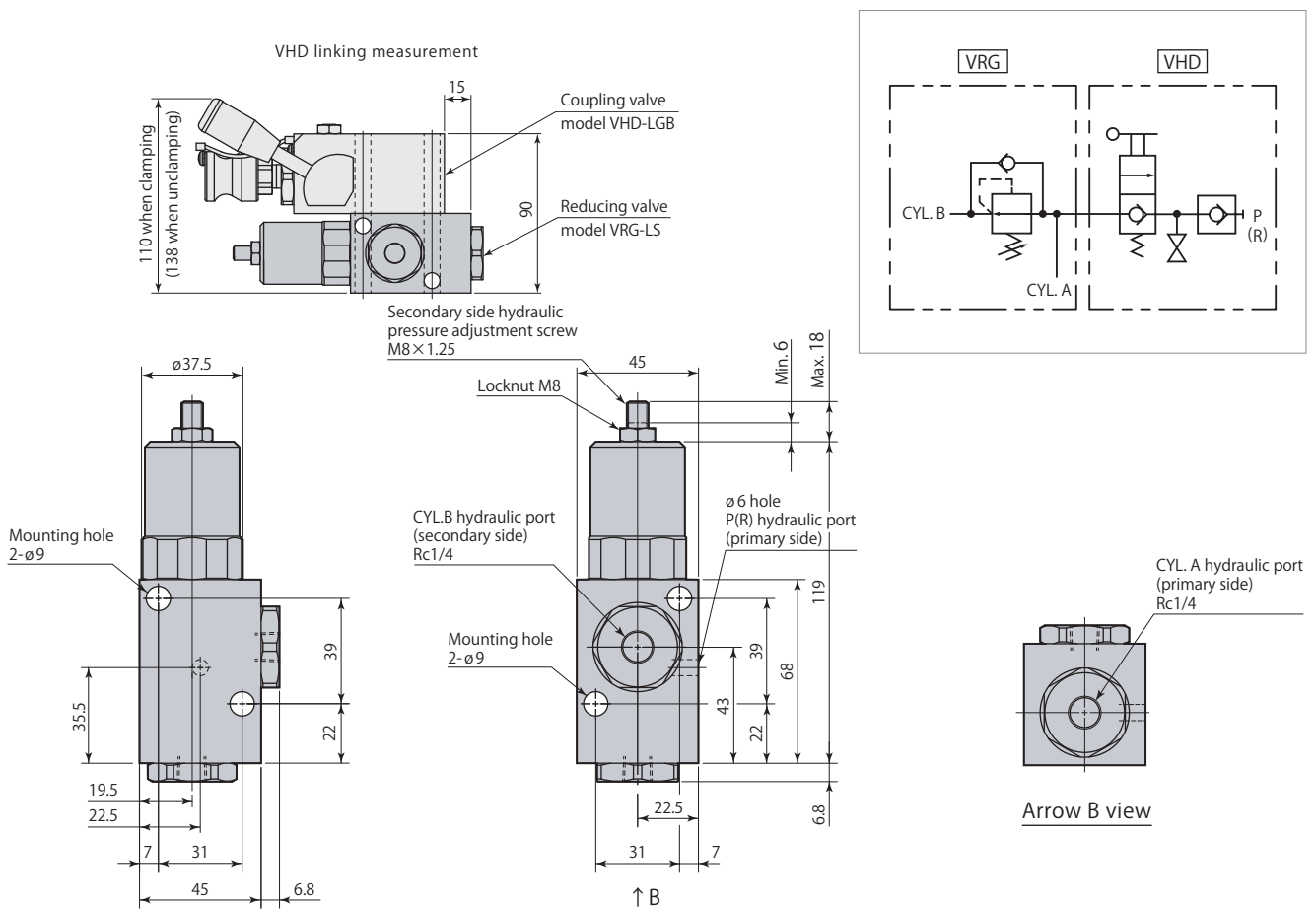

- Structure is such that when pressure on secondary side (low pressure side) drops due to temperature change or oil leak, flow channel to primary side (high pressure side) is opened to replenish oil until pressure reaches set pressure.
- Pressure is not supplemented when primary side is separated from hydraulic pressure source.
- Mounting screws are not included.