

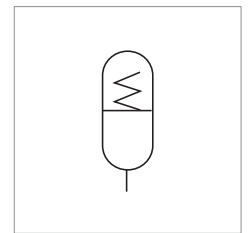

Accumulator model WPB

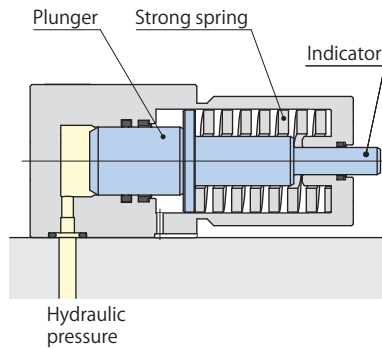

Spring pressure type accumulator. Pressure fluctuation that occurs due to temperature change after disengaging hydraulic pressure source is suppressed.

Specifications

Model	Oil discharge, absorption amount	Mounting method	Scraper, seal material
WPB 2	1 : 3.3 cm <sup>3</sup>	GB : Manifold, GB mounting	(Nil) : NBR (standard)
WPB 3	2 : 6.6 cm <sup>3</sup>	GS : Manifold, GS mounting	V* : Fluorocarbon
WPB 4	3 : 13 cm <sup>3</sup>	T : Piping	
WPB 5			
WPB 6			
WPB 7			

\*:Fluorocarbon has been adopted for seal sections where cutting fluid is applied, as a measure for the use of chlorine-based cutting fluid (this is not thermal resistant specification).

Model	WPB2-1	WPB2-2	WPB2-3	WPB3-1	WPB3-2	WPB3-3	WPB4-1	WPB4-2	WPB4-3	
Hydraulic pressure MPa	Refer to page →227 for characteristic line diagram.									
Oil capacity cm <sup>3</sup>	3.3	6.6	13.0	3.3	6.6	13.0	3.3	6.6	13.0	
Pressure fluctuation per 1cm <sup>3</sup> MPa	0.55	0.38	0.19	0.50	0.33	0.17	0.43	0.29	0.14	
Mass kg	0.9	1.2	1.8	0.9	1.2	1.8	0.9	1.2	1.8	

Model	WPB5-1	WPB5-2	WPB5-3	WPB6-1	WPB6-2	WPB6-3	WPB7-1	WPB7-2	WPB7-3	
Hydraulic pressure MPa	Refer to page →227 for characteristic line diagram.									
Oil capacity cm <sup>3</sup>	3.3	6.6	13.0	3.3	6.6	13.0	3.3	6.6	13.0	
Pressure fluctuation per 1cm <sup>3</sup> MPa	0.41	0.27	0.16	0.90	0.61	0.36	0.84	0.59	0.34	
Mass kg	1.3	1.7	2.4	1.3	1.7	2.4	1.3	1.7	2.4	

- Proof pressure: 7 MPa (WPB2, 3, 4) , 15 MPa (WPB5, 6, 7)
- Operating temperature: 0–70°C
- Fluid used: General mineral based hydraulic oil (ISO-VG32 or equivalent)

Accumulator

WPB Spring

Dimensions

WPB□-□□□-□ \*No internal filter

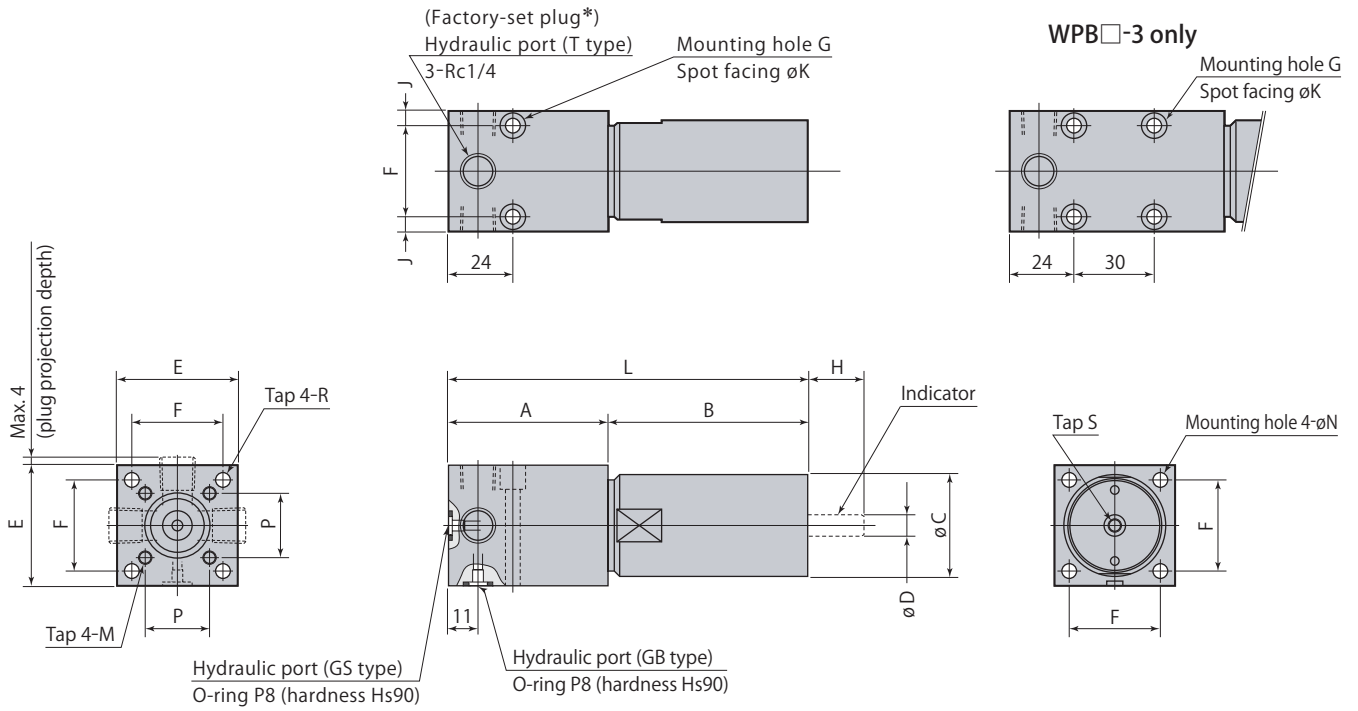

mm																	
Model		A	B	øC	øD	E	F	G	Max. H	J	øK	L	M	øN	P	R	S
WPB 2 3 4	-1	49	46	38	8	45	34	2-ø5.5	10.5	5.5	9.5 depth 9	95	M5×0.8 depth 10	5.5	24	-	M5×0.8 depth 9
	-2	59.5	74.5					2-ø5.5	21			134					
	-3	80	151					4-ø5.5	41.5			231					
WPB 5 6 7	-1	49	70	42.7	10	50	38	2-ø6.8	10.5	6	11 depth 11	119	-	6.8	-	M8×1.25 depth 16	M6×1 depth 11
	-2	59.5	105					2-ø6.8	21			164.5					
	-3	80	186					4-ø6.8	41.5			266					

\* : Included plug T type: 2 pieces, GB & GS type: 3 pieces.

● Mounting screws are not included.

Mounting details

Manifold, GB mounting / Piping mounting

WPB□-1, WPB□-2

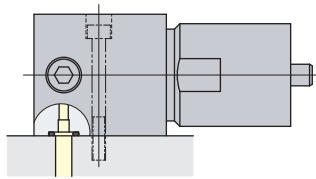
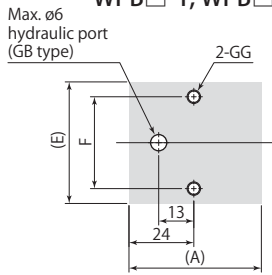

↑ Hydraulic pressure

WPB□-3

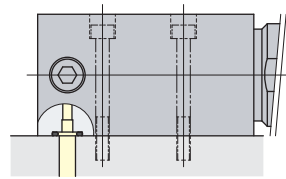
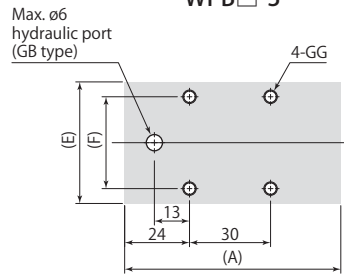

↑ Hydraulic pressure

Manifold, GS mounting ① / Piping mounting ①

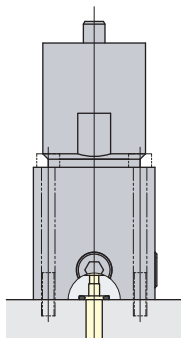
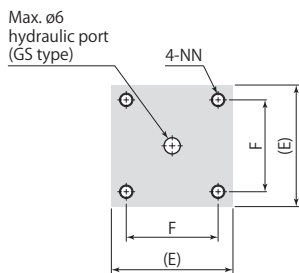

↑ Hydraulic pressure

Manifold, GS mounting ② / Piping mounting ②

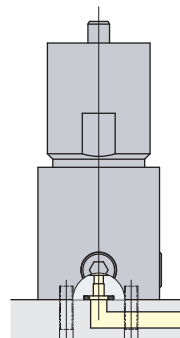
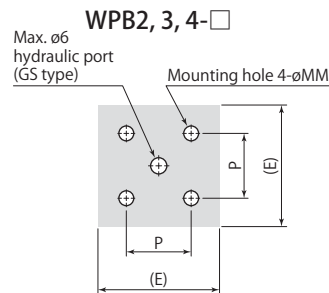

← Hydraulic pressure

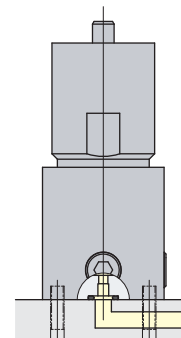
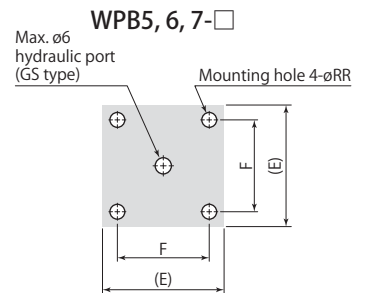

← Hydraulic pressure

When manifold piping, the mounting port surface finish must be no rougher than Rz6.3 (ISO4287:1997).

Model	A	E	F	GG	øMM	NN	P	øRR	
WPB 2 3 4	-1	49	45	34	M5	5.5	M5	24	-
	-2	59.5							
	-3	80							
WPB 5 6 7	-1	49	50	38	M6	-	M6	-	9
	-2	59.5							
	-3	80							

mm

Characteristic line diagram

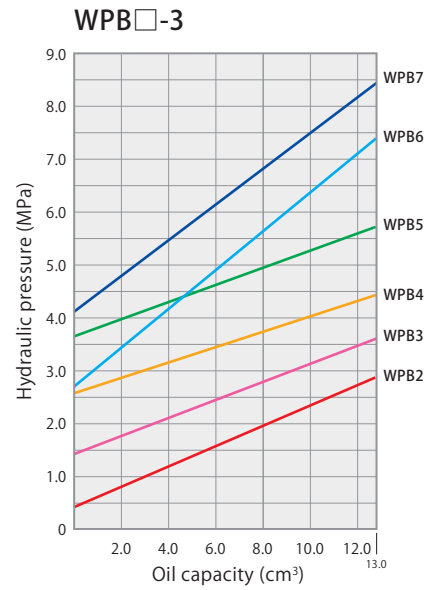
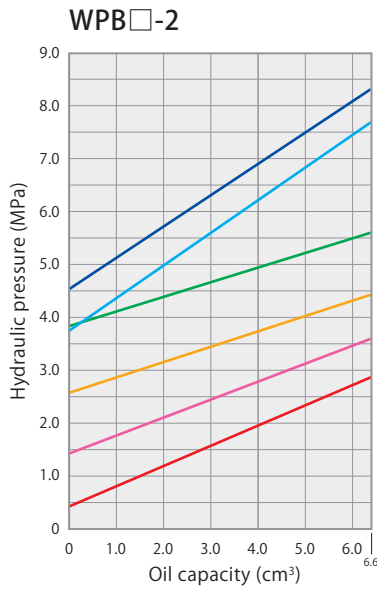
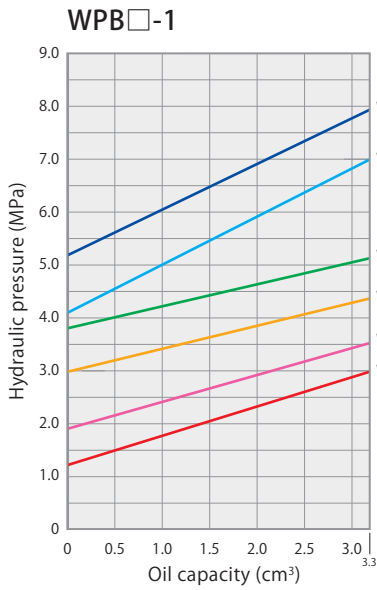

This characteristic line diagram represents theoretical values.

Model selection example

Condition (estimated temperature drop : 20°C )

Working clamp	CLU06×4 pieces	Piping	Inner diameter ø6×0.6m×4 pieces
Hydraulic pressure:P	3.5 MPa	Valve & hydraulic pressure equipment	VCB : 1 piece, VRG : 2 pieces

Selection procedure

1. Calculation of circuit capacity

Clamping capacity :  $\frac{9.6 \times 2.6 \times 4}{\text{Pressure bearing area} \times \text{Stroke} \times \text{Qty}} = 100 \text{ cm}^3$

Piping capacity :  $0.283 \times 60 \times 4 = 68 \text{ cm}^3$

Valve & hydraulic equipment capacity :  $8 \times 3 = 24 \text{ cm}^3$

(Perform calculation with capacity of 8 cm<sup>3</sup> for each of valves and hydraulic equipment in hydraulic circuit, when using Pascal product.)

Circuit capacity :  $100 + 68 + 24 = 192 \text{ cm}^3$
2. Selection of oil capacity

Select the equipment having oil capacity capable of keeping volumetric change.

Volumetric change is obtained by using formula shown below.

$\Delta V = V \times \Delta T \times \alpha$   $\Delta V$ : Volumetric change (cm<sup>3</sup>)  $V$ : Circuit capacity (cm<sup>3</sup>)

$\Delta T$ : Temperature change (°C)  $\alpha$ : Thermal expansion coefficient ( $7.8 \times 10^{-4}$ )

$\Delta V = 192 \times 20 \times 7.8 \times 10^{-4} = 3.0 \text{ cm}^3$

Here, WPB□-2 is selected as an example (\*1).
3. Selection of WPB hydraulic pressure

Select the pressure whose oil discharge amount (\*2) under hydraulic pressure satisfies  $\Delta V$  calculated in step 2. Read off characteristic line diagram.

If the hydraulic pressure is 3.5 MPa, select WPB3-2 or WPB4-2.
4. Verification of hydraulic pressure and residual discharge amount (\*2) after temperature change

Select the one whose hydraulic pressure drop after temperature change is low and residual discharge amount (\*2) satisfies the marginal oil amount (\*3). Read off characteristic line diagram.

The hydraulic pressure after temperature change drops to 2.5 MPa with WPB3-2 (P3) and to 2.6 MPa with WPB4-2 (P4).

The residual discharge amount (\*2) becomes 3.3 cm<sup>3</sup> with WPB3-2 (V3) and 0.3 cm<sup>3</sup> with WPB4-2 (V4).

In this case, select WPB3-2□ with the marginal amount retained.
5. Select piping method.

\*1 : WPB□-1 and WPB□-3 are also selectable. Likewise, select appropriate one in consideration of steps 3 and 4.

\*2 : For when the temperature decreases. If the temperature increases, check the absorption amount.

\*3 : Allow adequate margin for residual discharge amount after temperature change, as there may be margin of error with spring force of internal spring.

Marginal oil amount : WPB□-1 : About 0.5 cm<sup>3</sup>, WPB□-2 : About 1.0 cm<sup>3</sup>, WPB□-3 : About 1.5 cm<sup>3</sup>

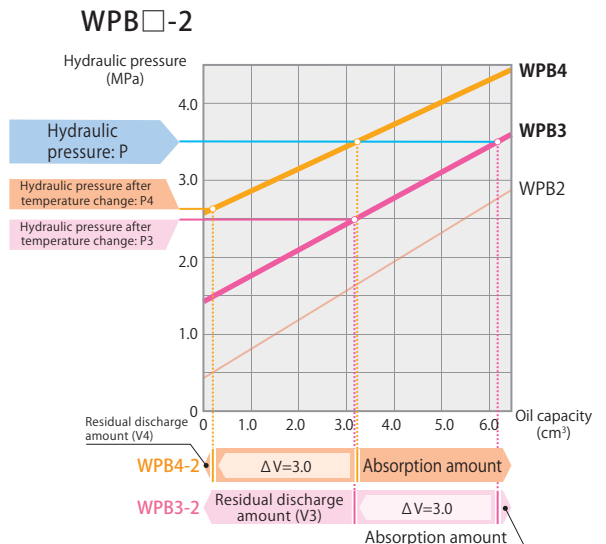
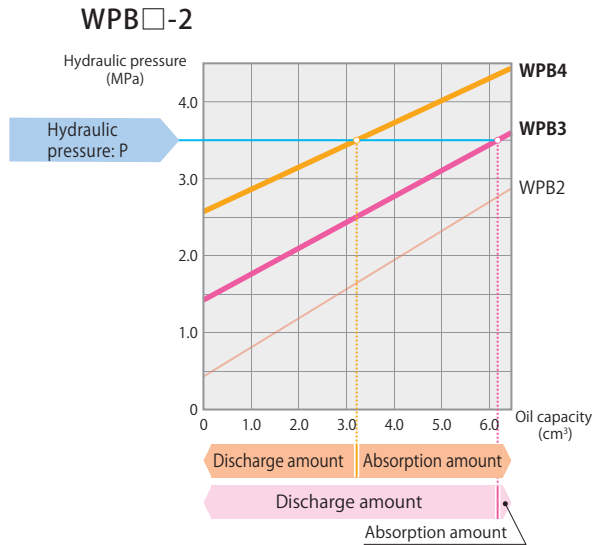

Accumulator  
WPB Spring