

Pascal

90°index table

High-speed 90°indexing with high accuracy

Roller gear cam drive & Hirth coupling 90°index table

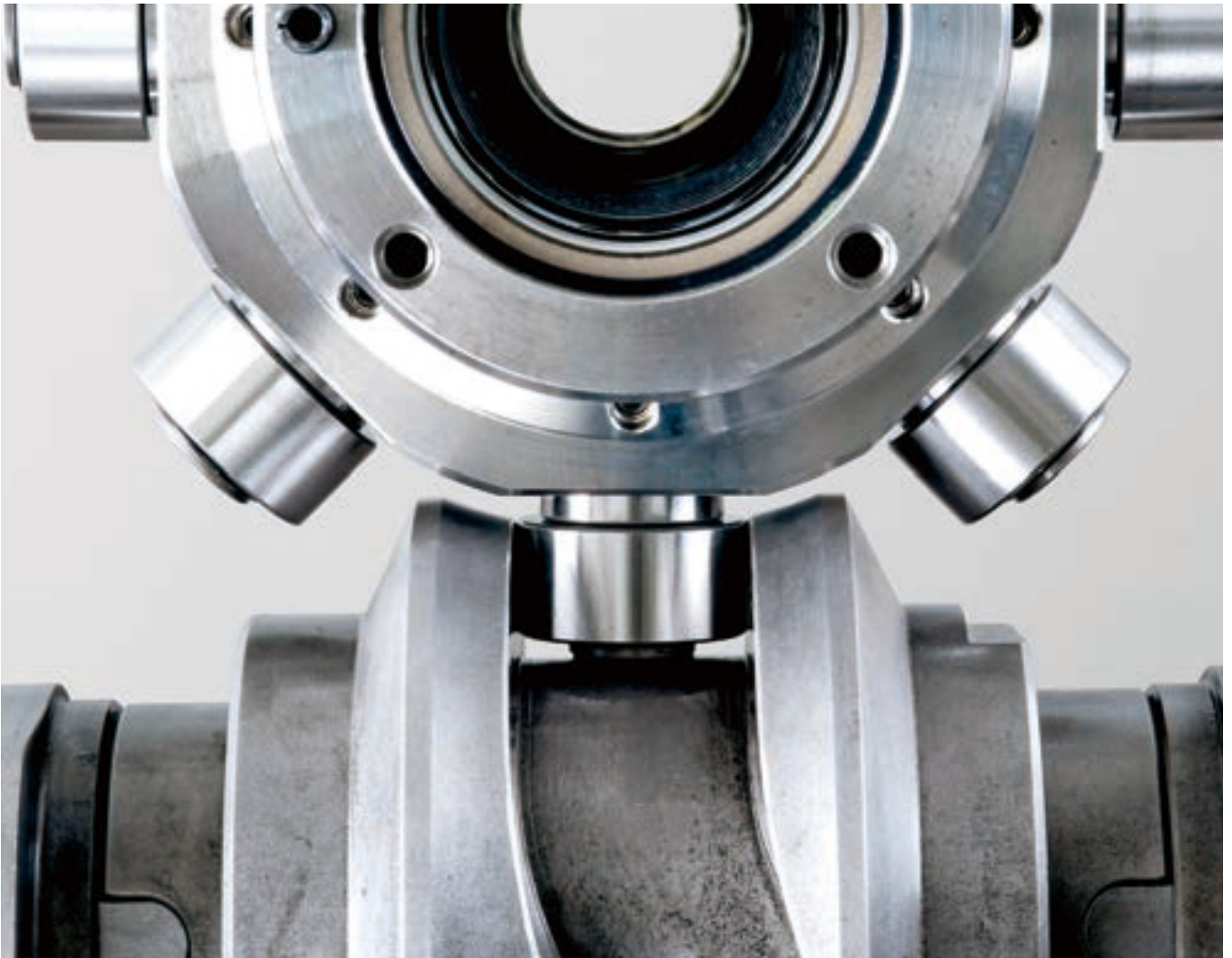

model **MDX**

Pascal 90°index table

Roller gear cam drive & Hirth coupling 90°index table

90°indexing **0.5**sec.

Index accuracy **±5** arc sec.

Quick, Accurate, durable, 1 million rotation No adjustment.

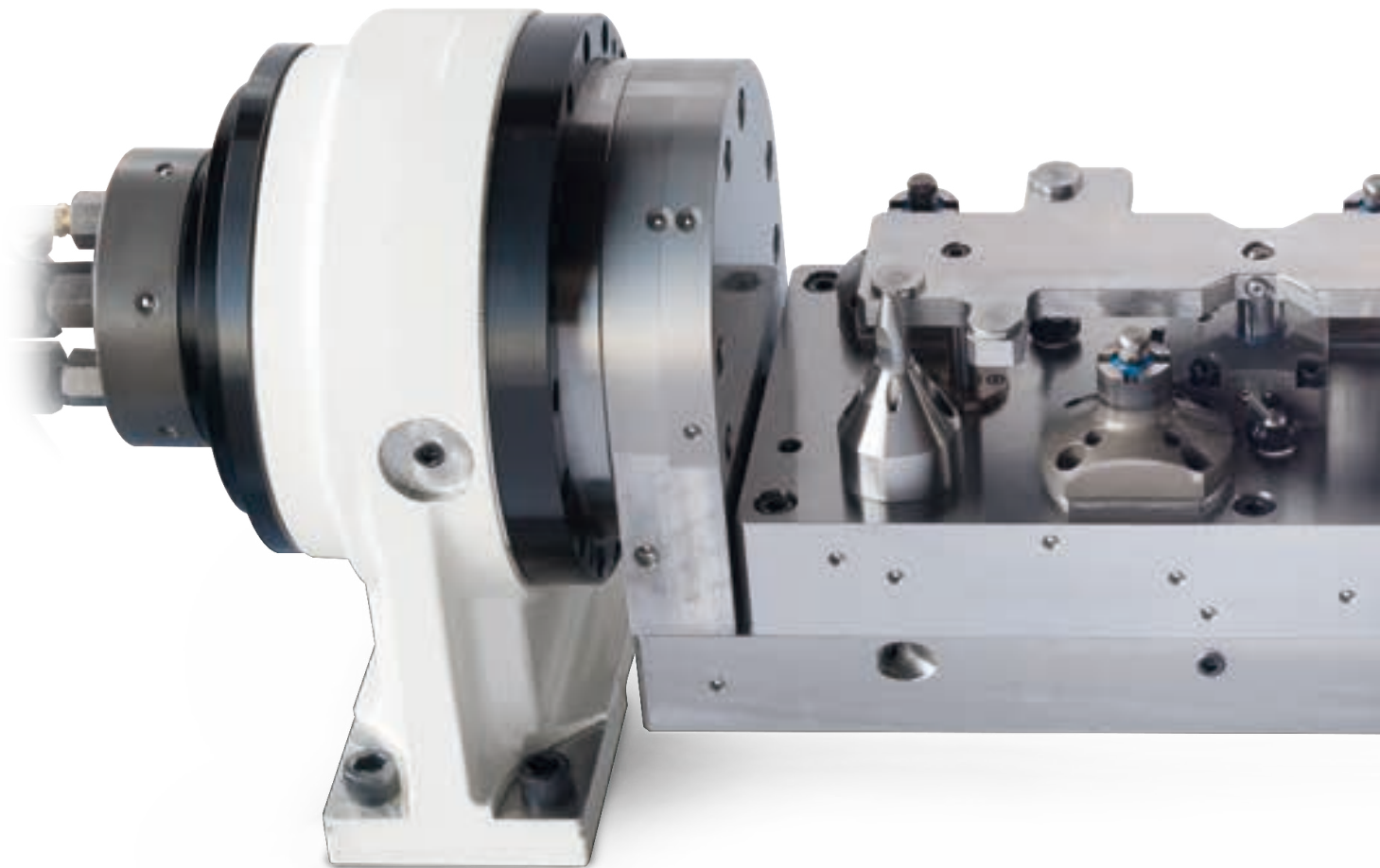

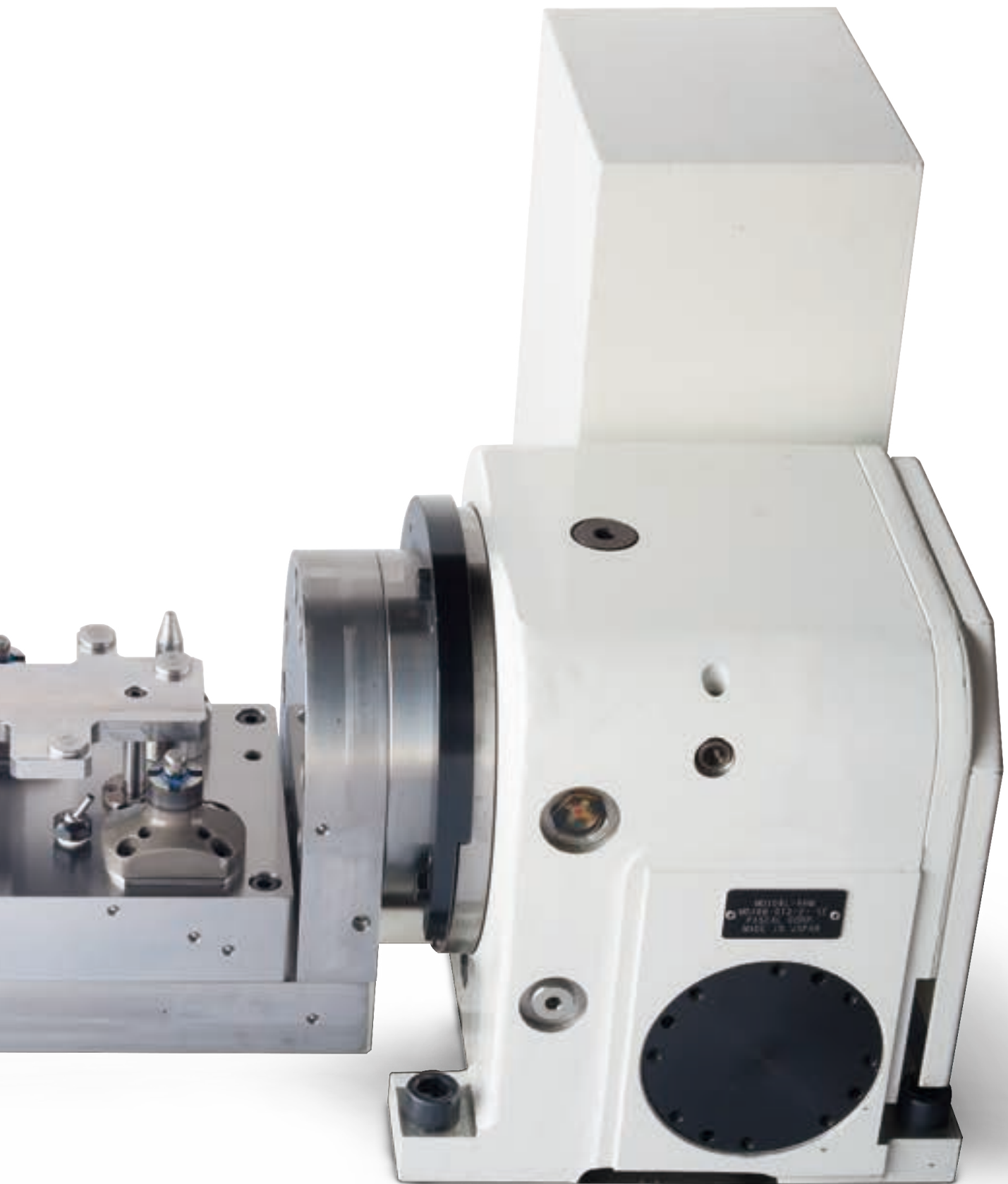

90° index table model MDX

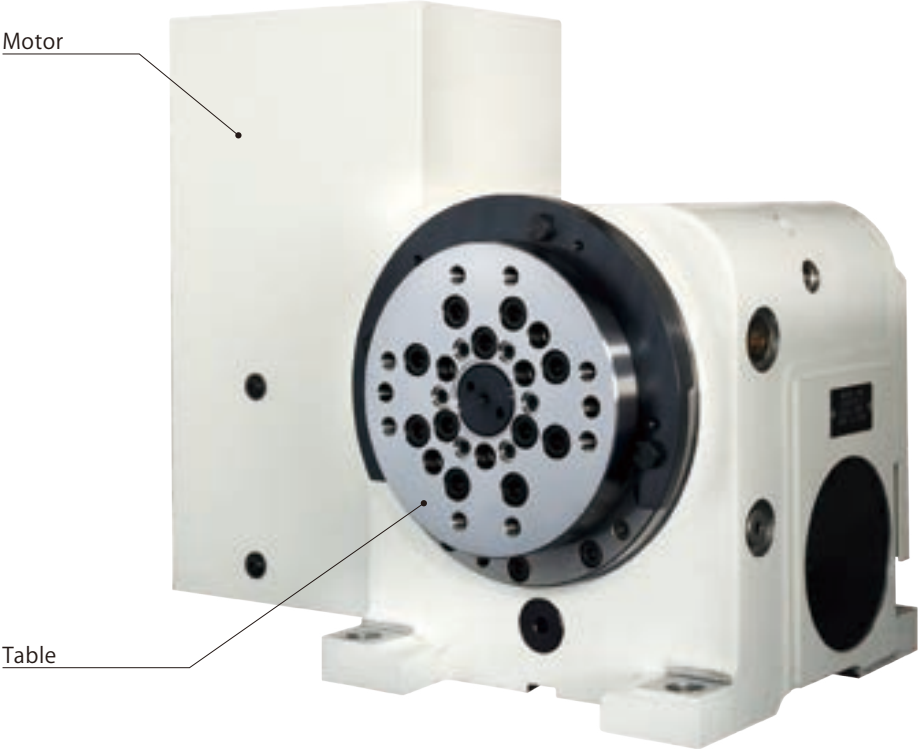

Support table model MDS



Optimum cam curve makes the speed and durability

- Roller gear cam drive provides smooth acceleration and deceleration movement according to the machine characteristic by adapting a cam curve.

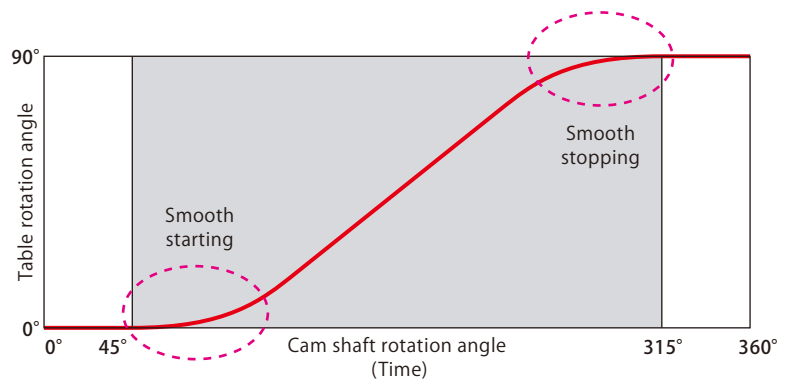

In case of worm gear...

In case of worm gear drive, the worm wheel rotation angle is represented by a rectilinear velocity-diagram as shown in the sketch below, also worm gear drive needs time for braking. To secure smooth acceleration and deceleration (start/stop), an expensive servo motor (NC additional axis control) must be required.

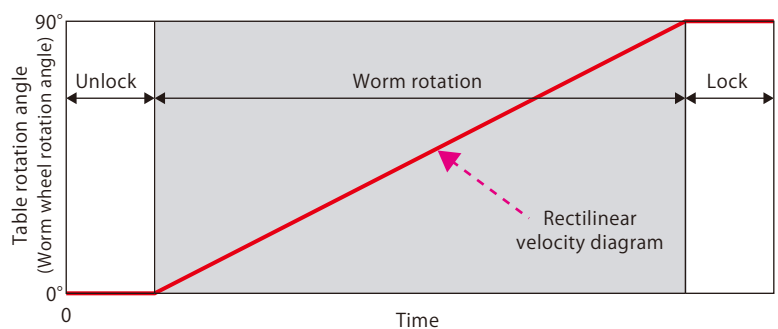
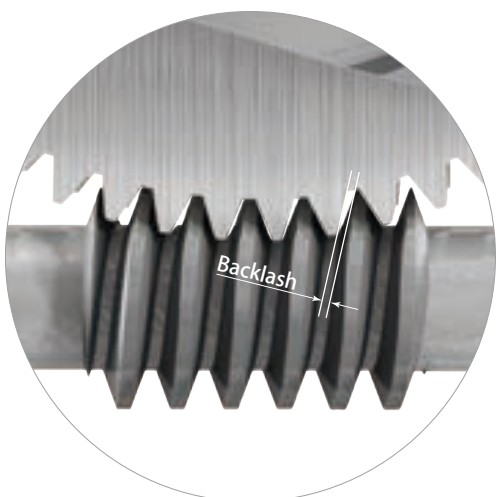

- There is the necessity of periodical backlash adjustment due to abrasive wear on worm gear.
- In case big rotational load exerted on the wormshaft, its support bearing requires a maintenance which has an effect on the durability of the mechanism.

90° indexing 0.5 sec.

Roller gear cam drive with an excellent indexing motion characteristic.

- Excellent movement characteristic by transmitting the roller gear cam rotation enables high speed indexing (90°- 0.5 sec.). Rolling transmission mechanism allows abrasive wear to be minimized also it can eliminate excessive load onto drive mechanism, which ensures quick start/stop operation even with an inverter control made by a general purpose motor allowing money-saving and high maintainability.

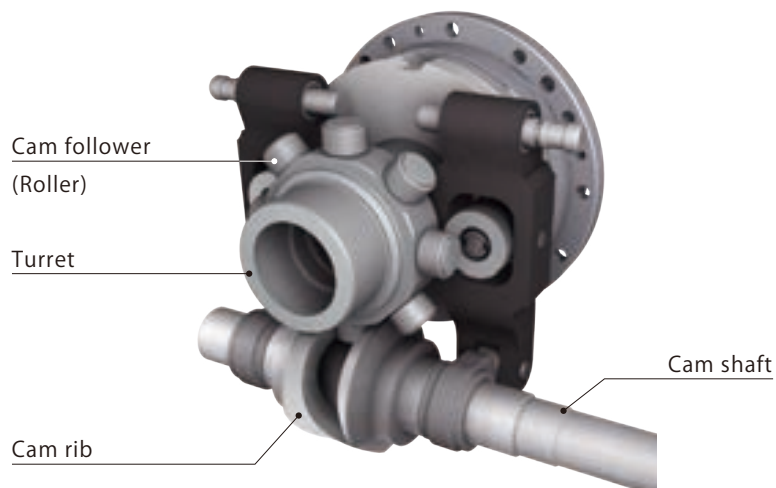
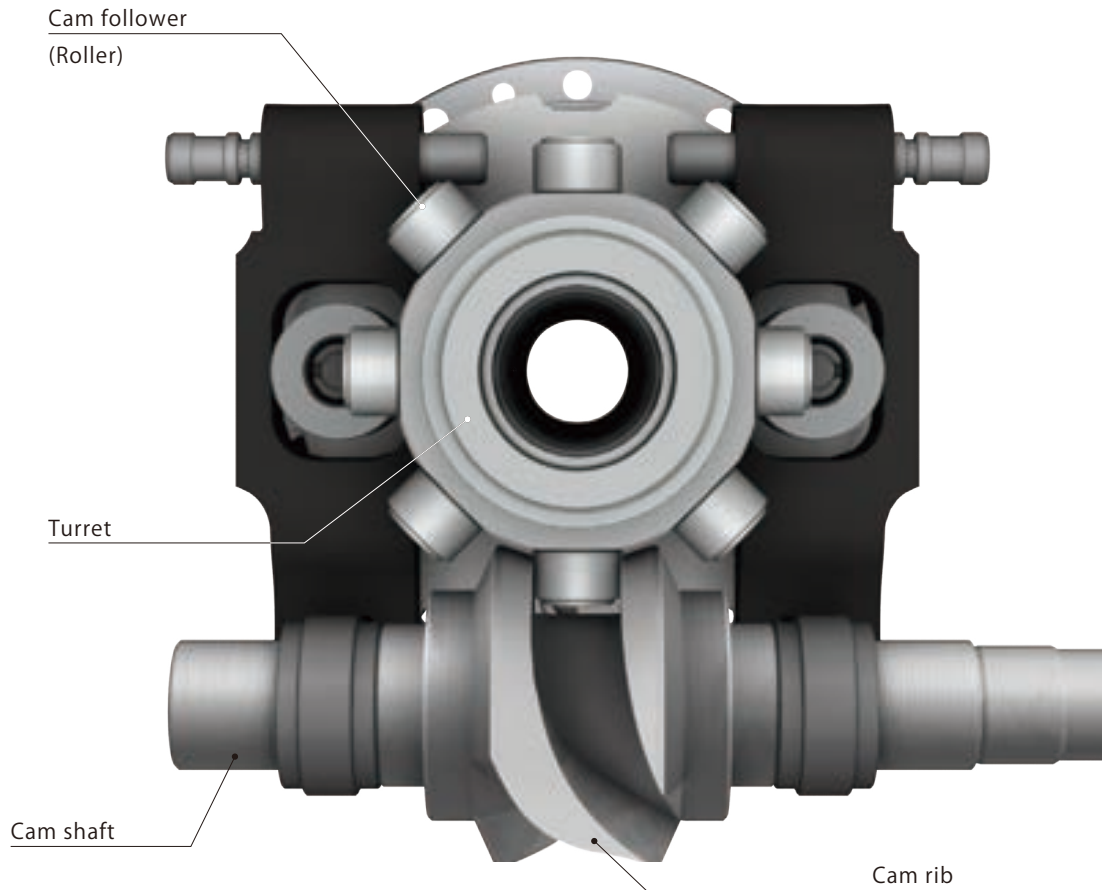

Index accuracy ± 5 arc sec.

Locking with 3-piece hirth coupling.

- Special three-piece hirth coupling is incorporated in the index lock system. This full mechanical lock system with a taper coupling maintains high indexing accuracy within $\pm 5^\circ$ for long period, which ensures high speed, heavy duty and high accuracy machining consistently.
- The tapered engaging position of the hirth coupling absorbs the misalignment caused by the backlash moderately provided for the roller gear cam, and mechanically indexes/holds the table at the desired angle with accuracy. A workpiece is held securely at a desired angle against the load torque and vibration during machining/cutting.
- Locking by using the hirth coupling synchronizes the movement of roller gear cam and there is no time lag between locking and unlocking action thereby enabling high speed indexing.

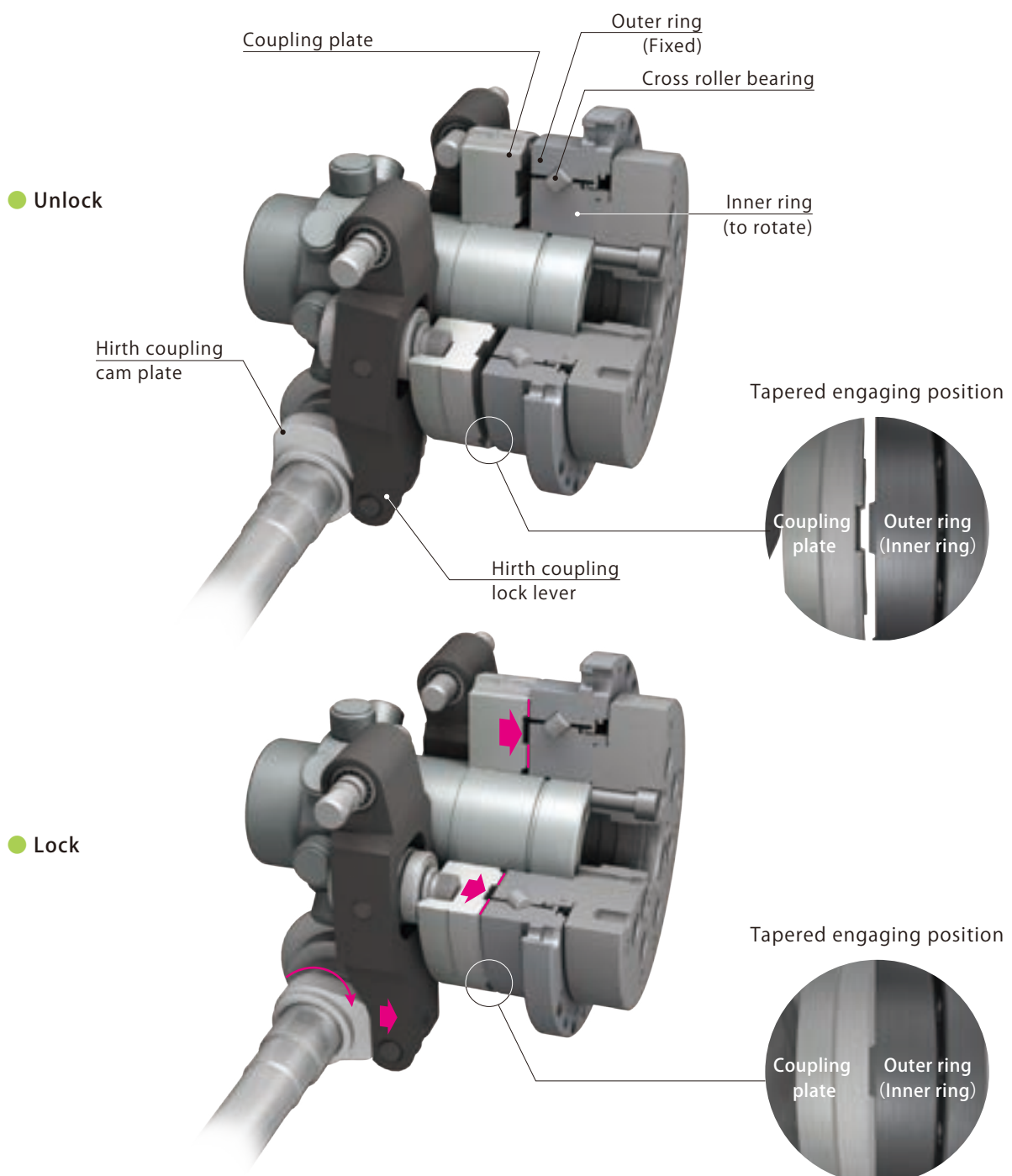

90° index table

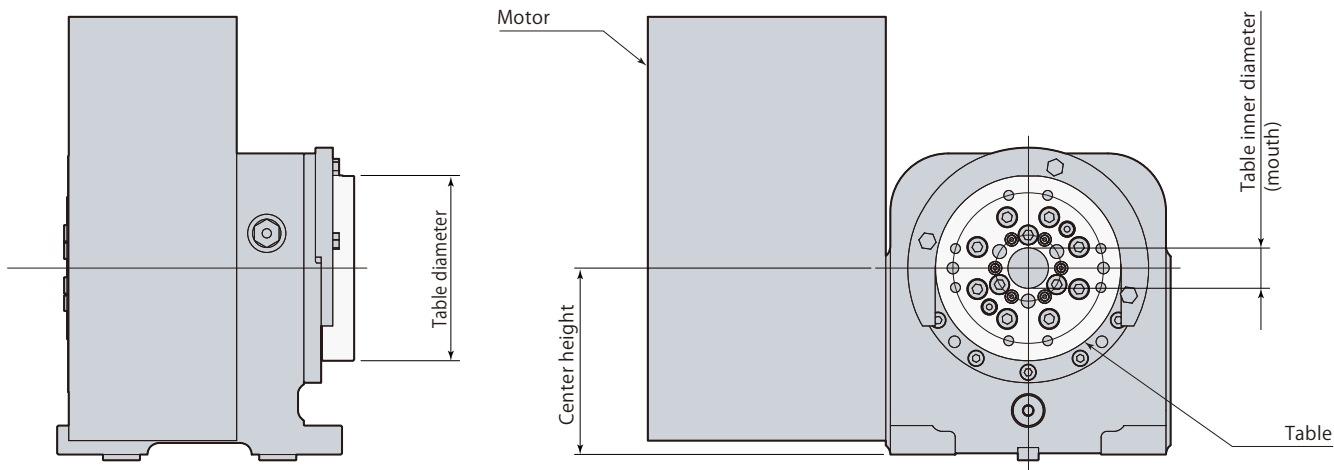

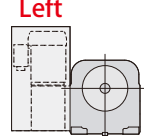
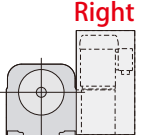
	Size	Motor mounting position	Option	
MDX	06	L : Left 	/ : Nil R : Built-in rotary joint H : Horizontal motor type W : Proximity sensor 3-wire	※ 2-wire for standard sensor. Specify 3-wire sensor when using a controller model EDX. page→10
	08	R : Right 		
		— 4		

Model		MDX06	MDX08
Table diameter	mm	ø160	ø200
Center height	mm	161	185
Table inner diameter (mouth)	mm	ø35	ø48
Mass	kg	65	140
Index accuracy	arc sec.	±5	
Repeatability	arc sec.	5	
Number of index		90° - 4 position	
90°index time (At motor speed1800rpm)	sec.	0.5	
Allowable payload (With support table)	kg	80 (160)	100 (200)
Allowable workpiece inertia moment ※1	kg·m ²	0.91	2.02
Allowable load (When locked) ※2	kN	6	10
Allowable loaded torque (When locked) ※2	N·m	742	1032
Allowable loaded moment (When locked) ※2	N·m	280	357

※1 : It varies depending on the condition of usage. Refer to **page → 11**

※2 : The figure indicates the limiting value when independently applied.

● Refer to **page → 9** for the details of rotary joint type.

Support table

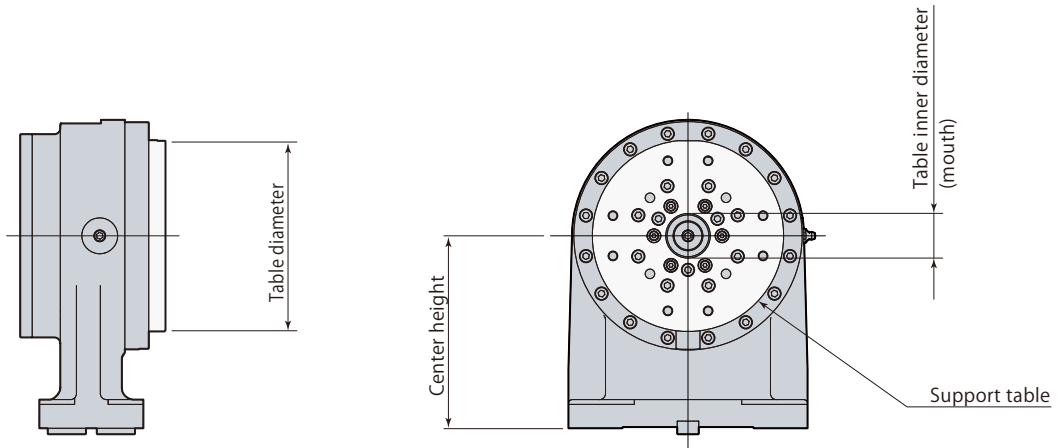

Thin and lightweight support table, which is feasible to have a rotary joint built-in, can optimize hydraulic or air jig pairing up with the rotary joint in MDX.

	Size	Option
MDS	06	∕ : Nil
	08	R : Built-in rotary joint

Model		MDS06	MDS08
Table diameter	mm	ø160	ø200
Center height	mm	161	185
Table inner diameter (mouth)	mm	ø35	ø48
Mass (Without rotary joint)	kg	17	40
Mass (With rotary joint)	kg	23	51

● Refer to page → 9 for the details of rotary joint type.

8ports 7 MPa
Built-in rotary joint

Built-in rotary joint type MDX is available as option.

It takes up minimum space on machine table also can maximize the cutting stroke of the machine.

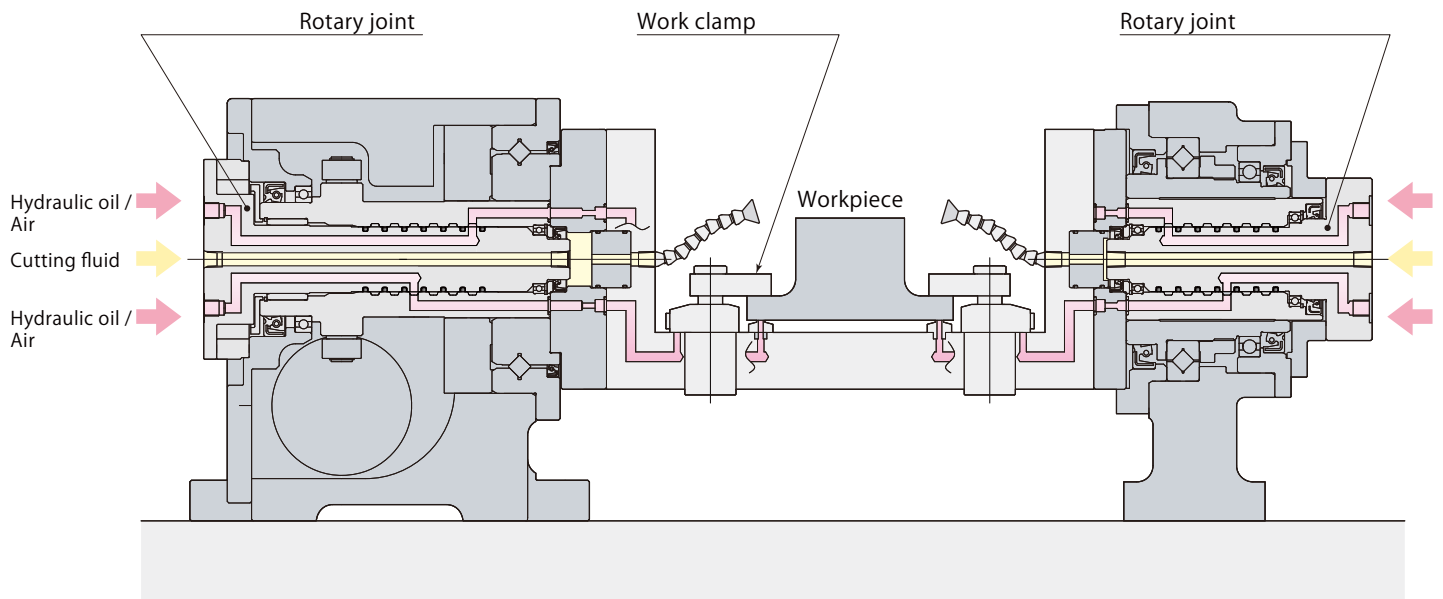

Size
 MD□ 06 - □ R : Built-in rotary joint
08

Model	MDX06-4R/MDS06-R	MDX08-R/MDS08-R
Hydraulic and air circuit	G1/8×6 ports	G1/8×8 ports
Working fluid	General mineral based hydraulic oil / Air	
Max working pressure	MPa	7.0
Cutting fluid circuit	Rc1/8×1port	Rc1/4×1port
Max cutting fluidt pressure	MPa	0.3

- When applying hydraulic oil to rotary joint, oil film leakage to adjacent circuits is inevitable. When the oil and air circuits are being allocated in one rotary joint, be sure to allocate a circuit between them as a drain circuit. (If the air circuit can tolerate the oil leakage, drain circuit is not mandatory.)
- Filtered cutting fluid should be supplied to the cutting fluid port.

Controller

The panel is a one axis controller because it controls MDX by means of M-code sent from the machining center control. It has indexing action complete by M-command alone.

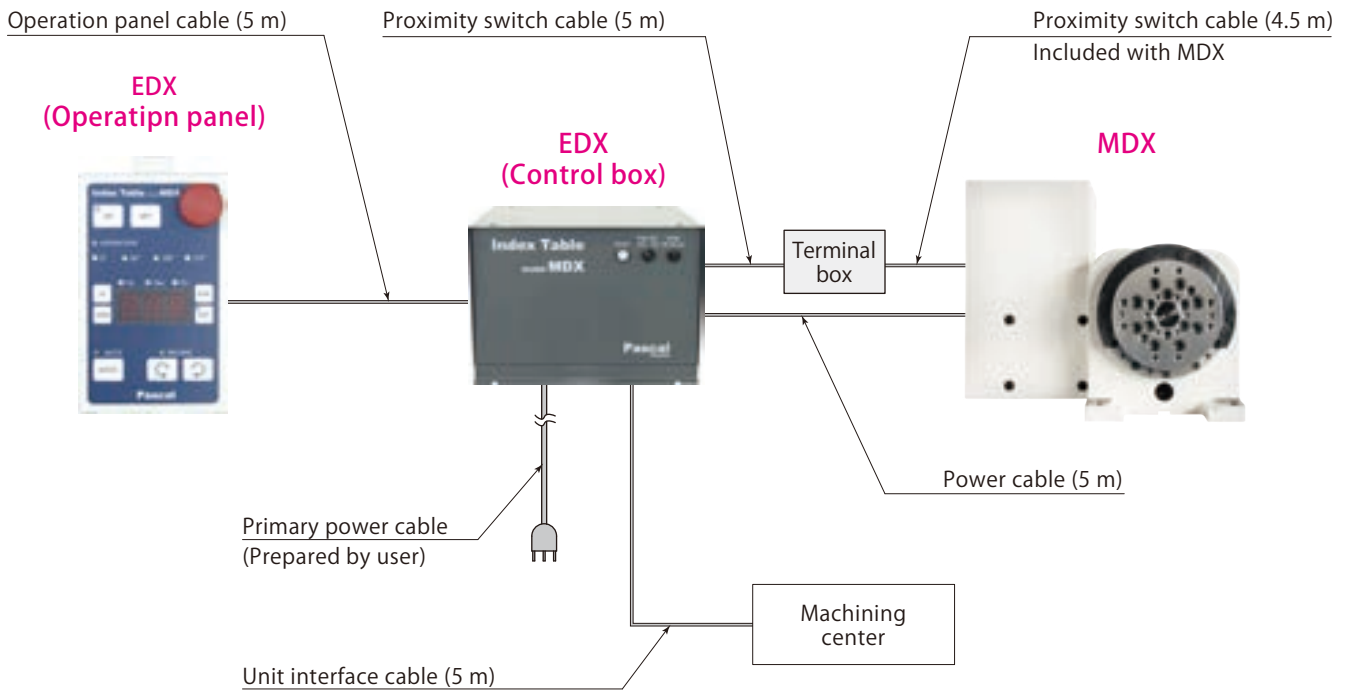

Size

- EDX**
- 06** (For MDX06)
 - 08** (For MDX08)

Model		EDX06	EDX08
Number of axis to control		1-axis control	
Power source		3-phase AC200V/220V±10% 50/60Hz	
Power source capacity	VA	700	1200
Signal interface		Serial signal : For operation panel (RS422) Parallel signal : For interlock	
Operating temperature range	°C	0 ~ 40	
Storage temperature	°C	-10 ~ 60	
Mass	kg	20 (Operating panel + Control box)	

Moment of Inertia for allowable workpiece

The weight of workpiece that can be rotated on the table varies in accordance with its shape and the center of gravity.

In case that the workpiece is odd shaped and unbalance torque may exert, MDX should be operated in usable range in the graph shown below.

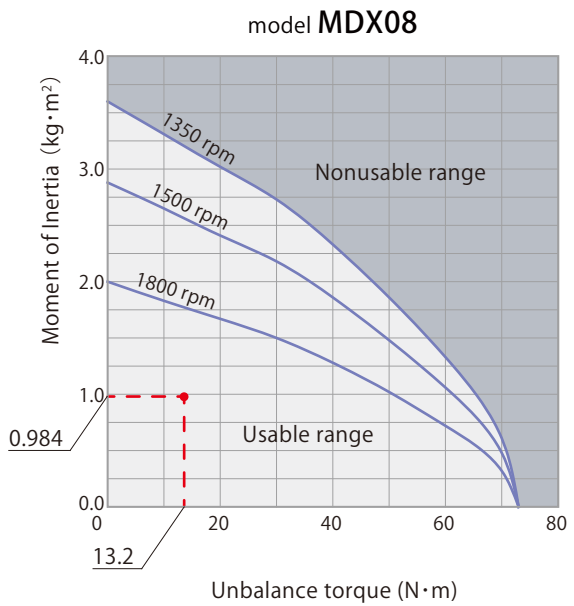
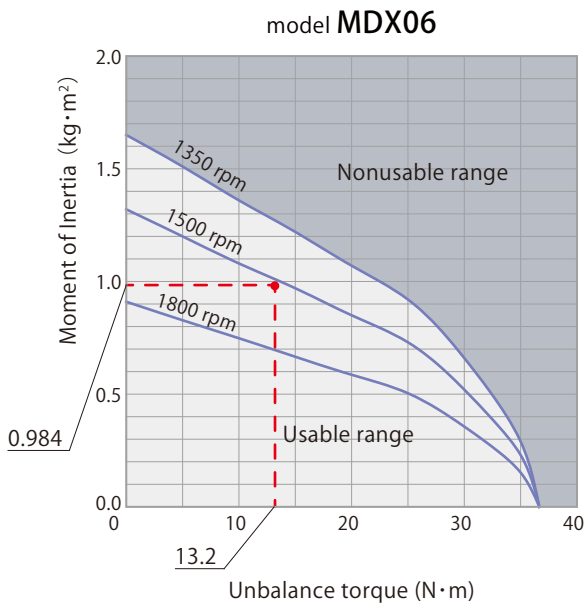

Example

Jig and workpiece total moment of inertia at 0.984 kg·m² / total unbalance torque 13.2 N·m

MDX06 : Motor speed 1500 rpm (90°index 0.6 sec.)

MDX08 : Motor speed 1800 rpm (90°index 0.5 sec.)

Calculation example for Moment of Inertia/unbalance torque

Moment of Inertia and unbalance torque must be calculated first to clarify inertial moment for allowable workpiece.

In addition, it varies not only the weight and eccentricity of workpiece but also the shape.

Example Calculate I (moment of inertia) and T (unbalance torque) of the following cylindrical and squared pole workpiece.

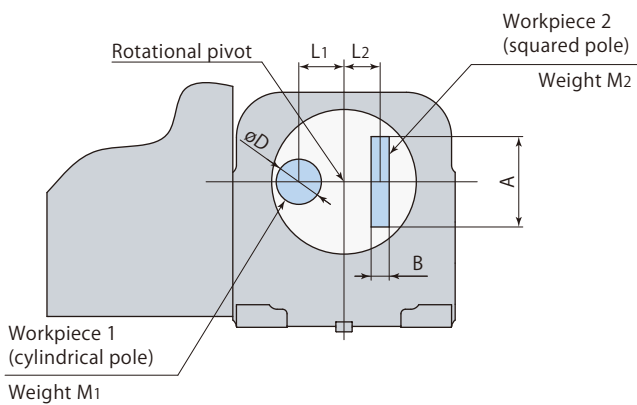

Workpiece 1 (cylindrical pole)	Workpiece 2 (squared pole)
Weight M ₁ : 60 kg	Weight M ₂ : 55 kg
Eccentricity L ₁ : 0.06 m	Eccentricity L ₂ : 0.09 m
Diameter D : 0.12 m	Height A : 0.21 m
	Wide B : 0.05 m

- Eccentricity represents the distance from the center of rotation to the center of gravity of workpiece.

- STEP1 : Calculate moment of inertia I around the center of gravity.

$$\textcircled{1} \text{Workpiece 1 (cylindrical pole)} \quad I_{1A} = \frac{1}{8} \times M_1 \times D^2 = \frac{1}{8} \times 60 \times 0.12^2 = 0.108 \text{ kg}\cdot\text{m}^2$$

$$\textcircled{2} \text{Workpiece 2 (squared pole)} \quad I_{2A} = \frac{1}{12} \times M_2 \times (A^2 + B^2) = \frac{1}{12} \times 55 \times (0.21^2 + 0.05^2) = 0.214 \text{ kg}\cdot\text{m}^2$$

- STEP2 : Calculate moment of inertia I around the rotational pivot.

$$\textcircled{1} \text{Workpiece 1 (cylindrical pole)} \quad I_1 = I_{1A} + M_1 \times L_1^2 = 0.108 + 60 \times 0.06^2 = 0.324 \text{ kg}\cdot\text{m}^2$$

$$\textcircled{2} \text{Workpiece 2 (squared pole)} \quad I_2 = I_{2A} + M_2 \times L_2^2 = 0.214 + 55 \times 0.09^2 = 0.660 \text{ kg}\cdot\text{m}^2$$

- STEP3 : Calculate unbalance torque T

$$\textcircled{1} \text{Workpiece 1 (cylindrical pole)} \quad T_1 = 9.8 \times M_1 \times L_1 = 9.8 \times 60 \times 0.06 = 35.3 \text{ N}\cdot\text{m}$$

$$\textcircled{2} \text{Workpiece 2 (squared pole)} \quad T_2 = 9.8 \times M_2 \times L_2 = 9.8 \times 55 \times 0.09 = 48.5 \text{ N}\cdot\text{m}$$

- STEP4 : Calculate total inertia moment I and unbalance torque T

$$\text{Total Moment of Inertia} \quad I = I_1 + I_2 = 0.324 + 0.660 = 0.984 \text{ kg}\cdot\text{m}^2$$

$$\text{Total unbalance torque} \quad T = T_2 - T_1 = 48.5 - 35.3 = 13.2 \text{ N}\cdot\text{m}$$

※ Moment of Inertia will not be offset.

Motor mounting position

Left : MDX06L-4R

Right : MDX06R-4R

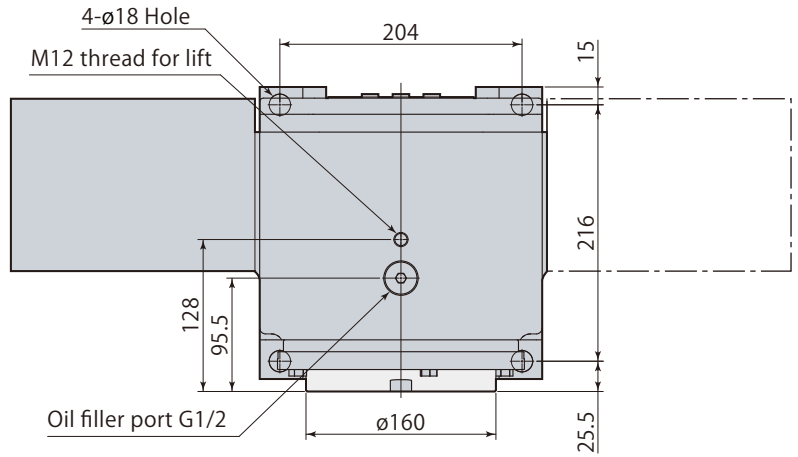

Detail R

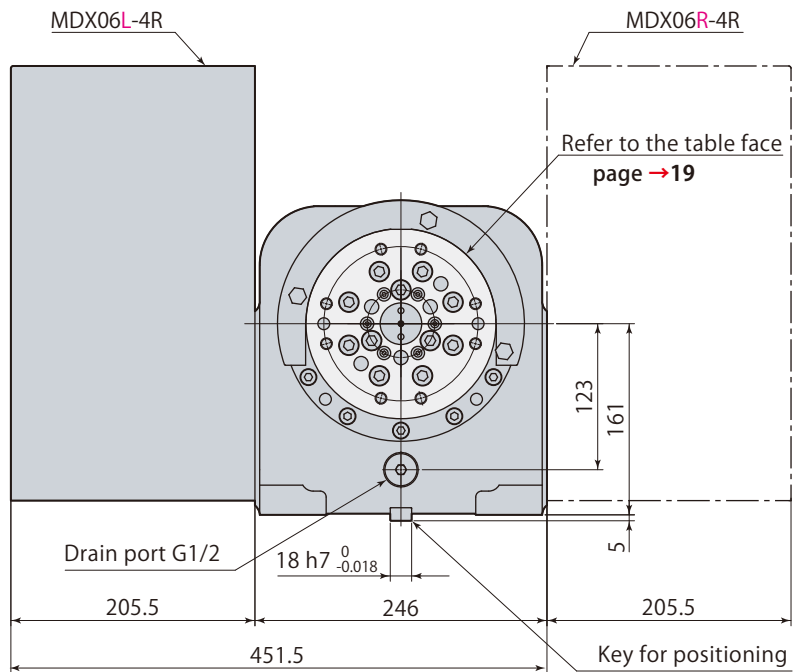
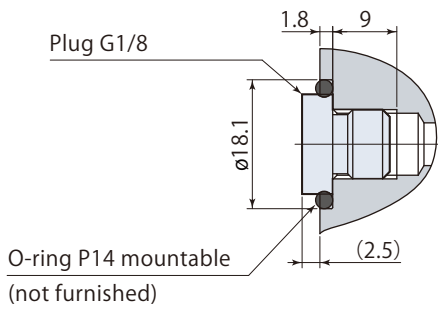

Detail R

Primary connection port 6-G1/8

Cutting fluid connection port Rc1/8

Drain port G1/2

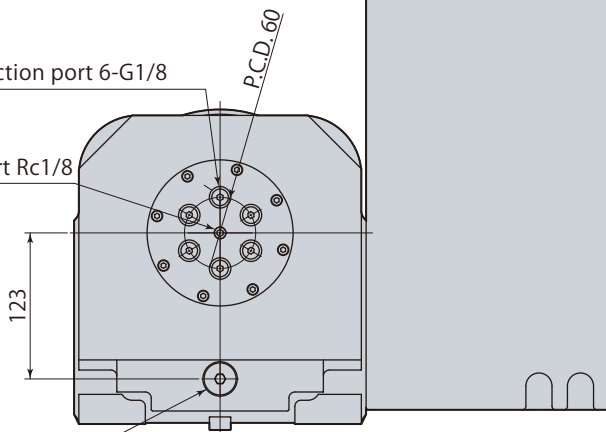

Oil level gauge (2 sides)

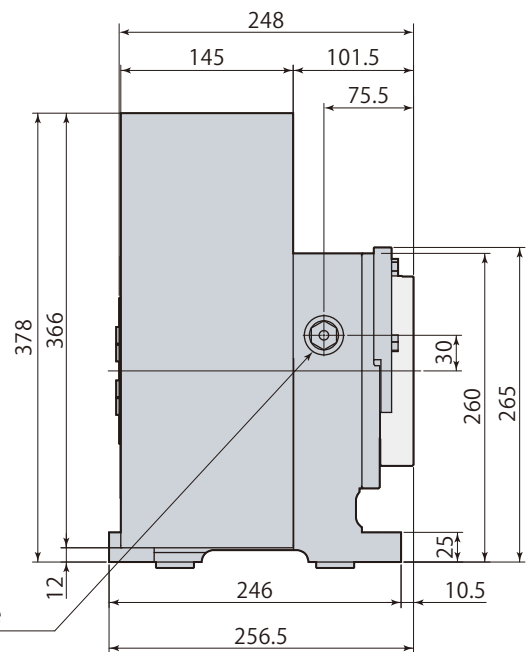

Motor mounting position

Left : MDX06L-4RH

Right : MDX06R-4RH

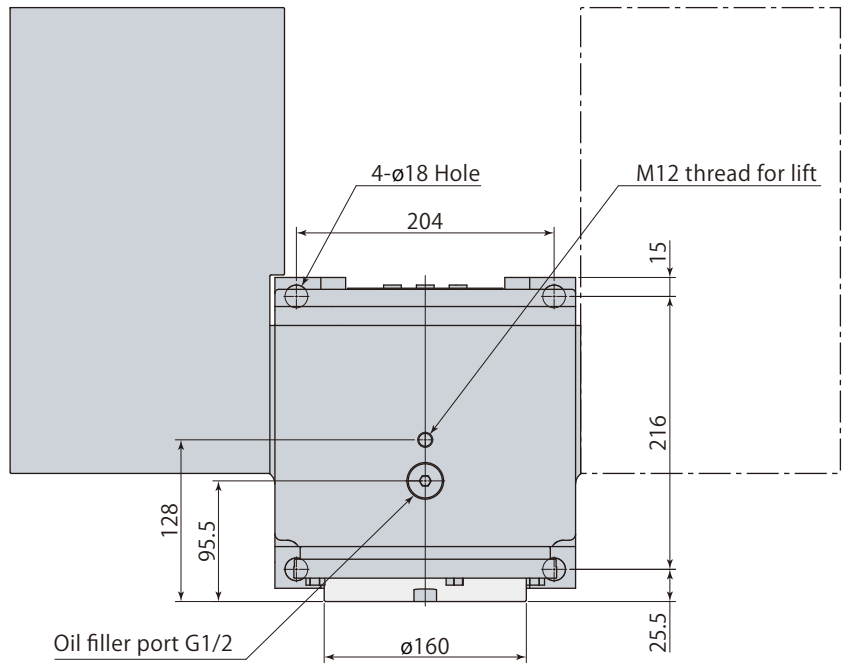

Detail R

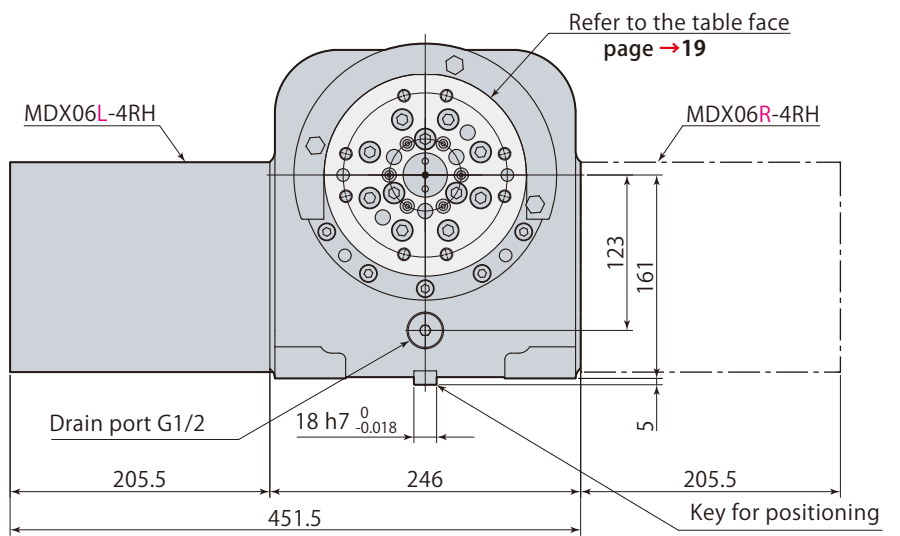
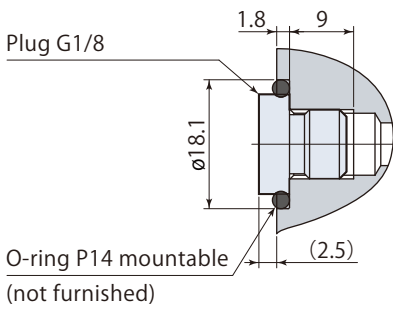

Detail R

Primary connection port 6-G1/8

Cutting fluid connection port Rc1/8

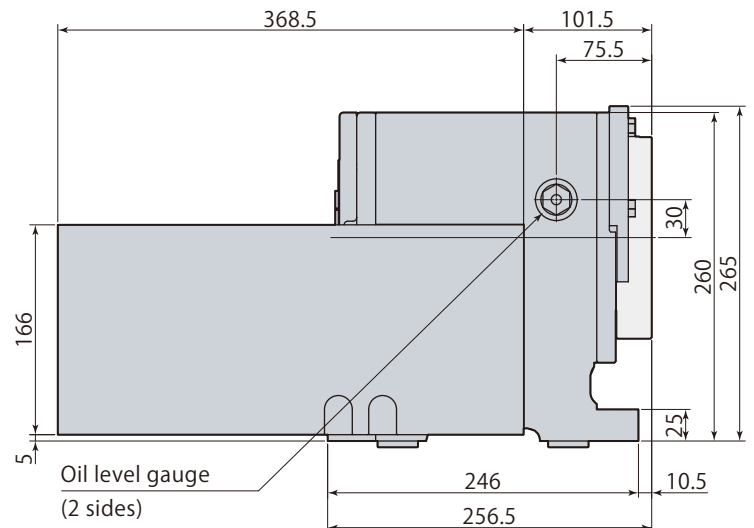
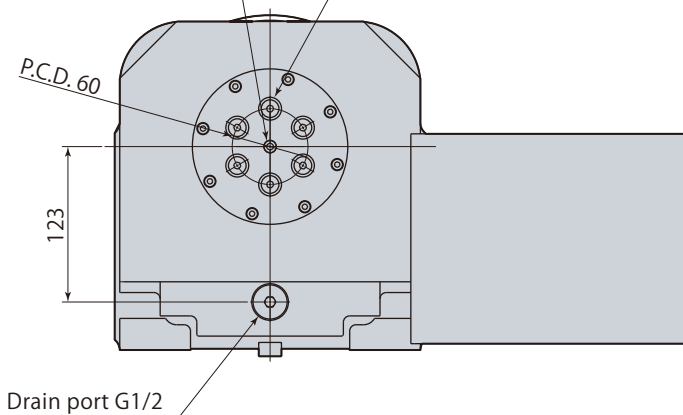

Motor mounting position

Left : MDX06L-4

Right : MDX06R-4

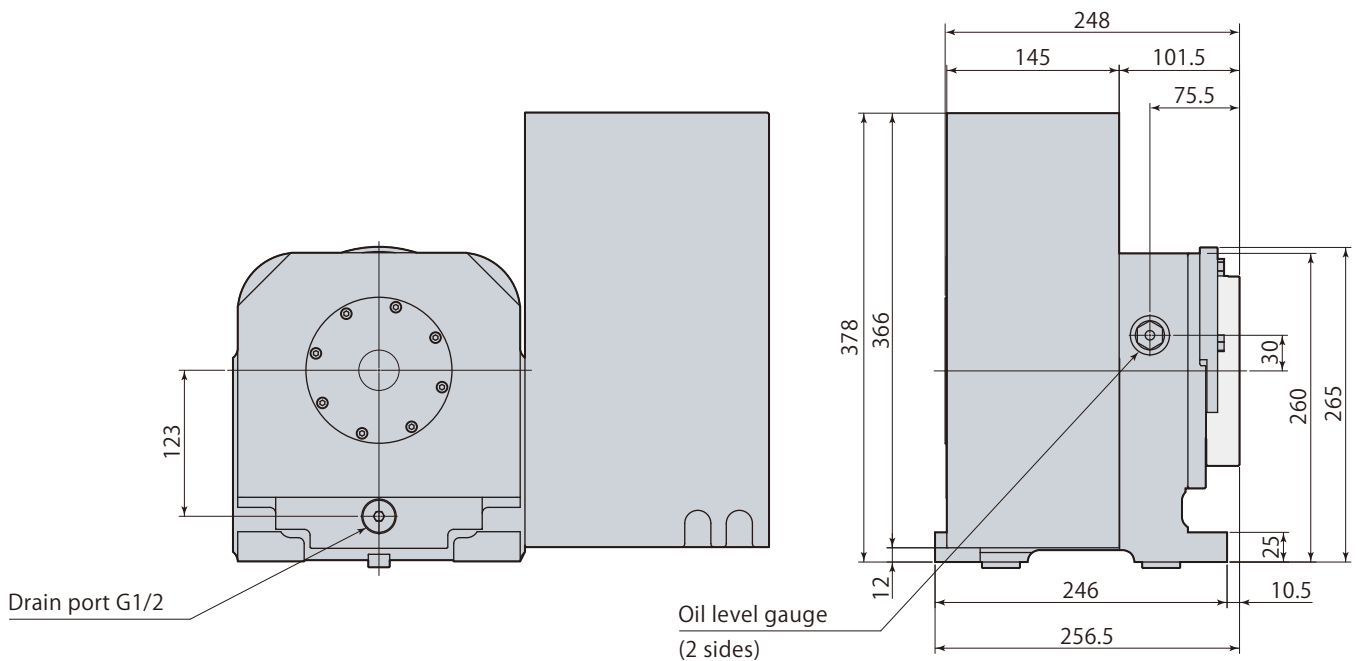
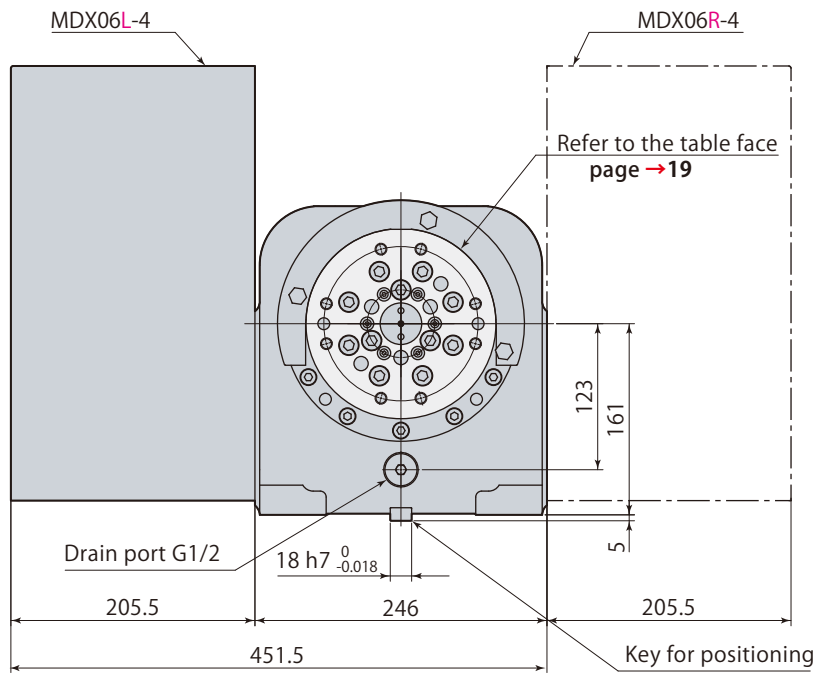
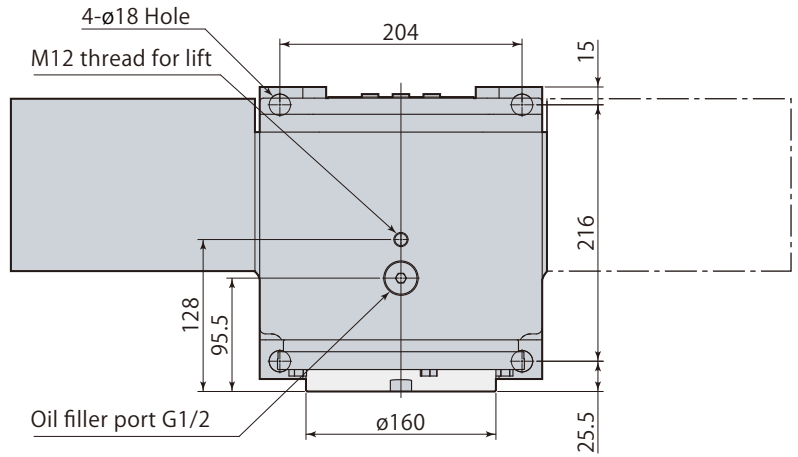

Motor mounting position

Left : MDX06L-4H

Right : MDX06R-4H

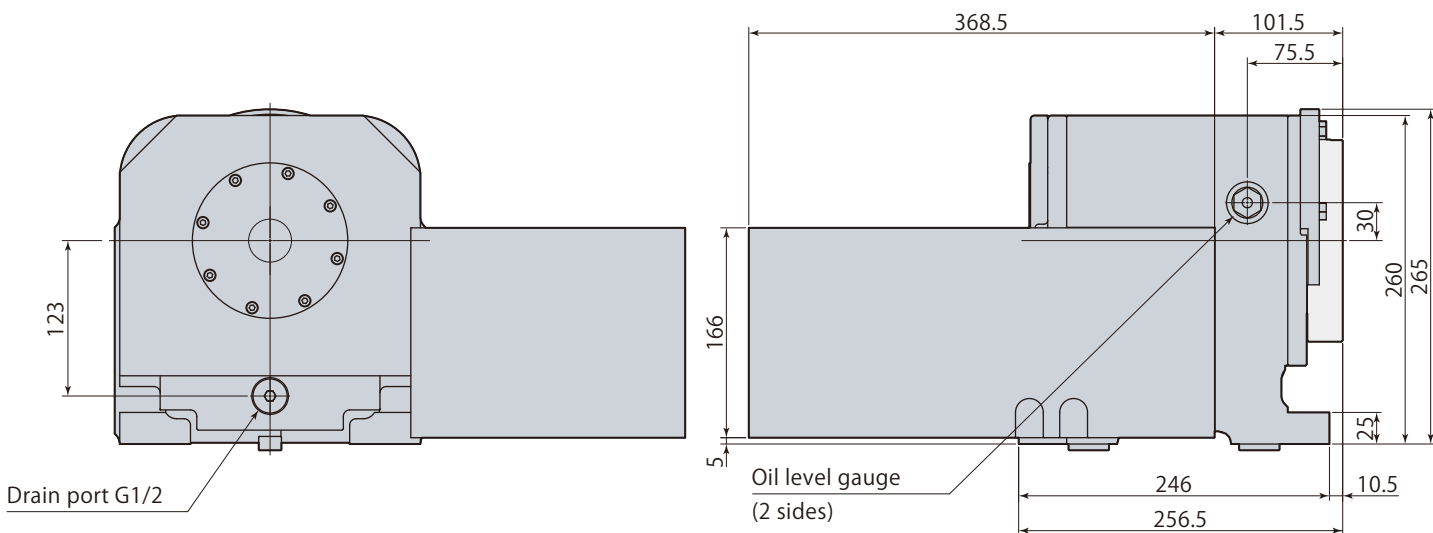
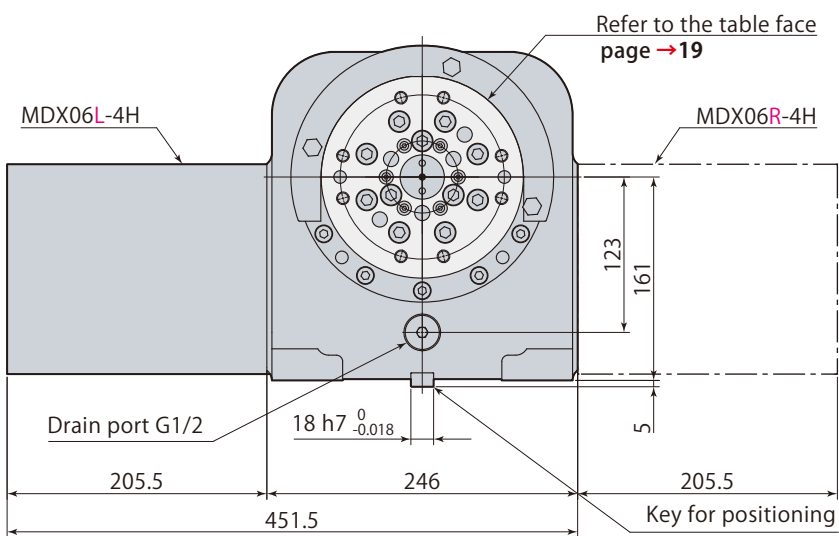
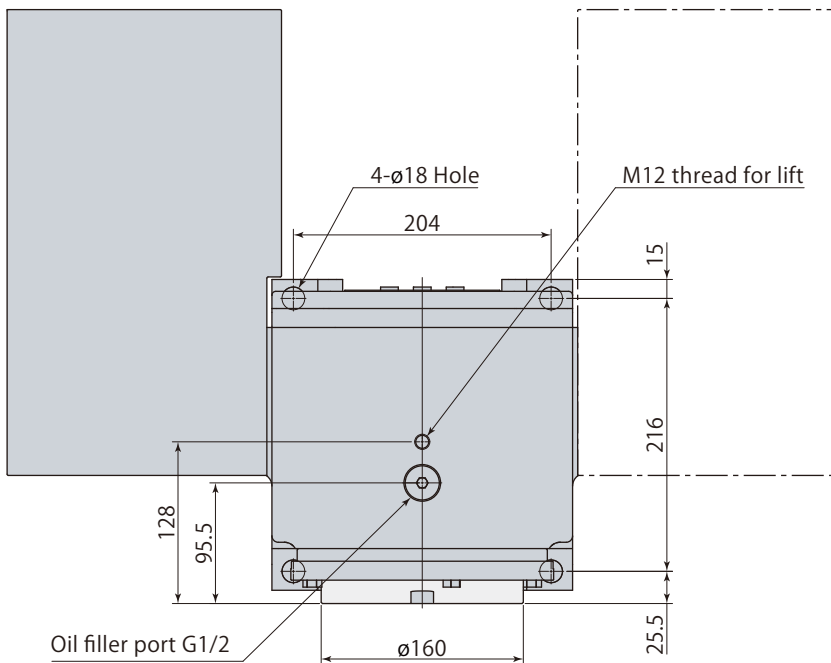

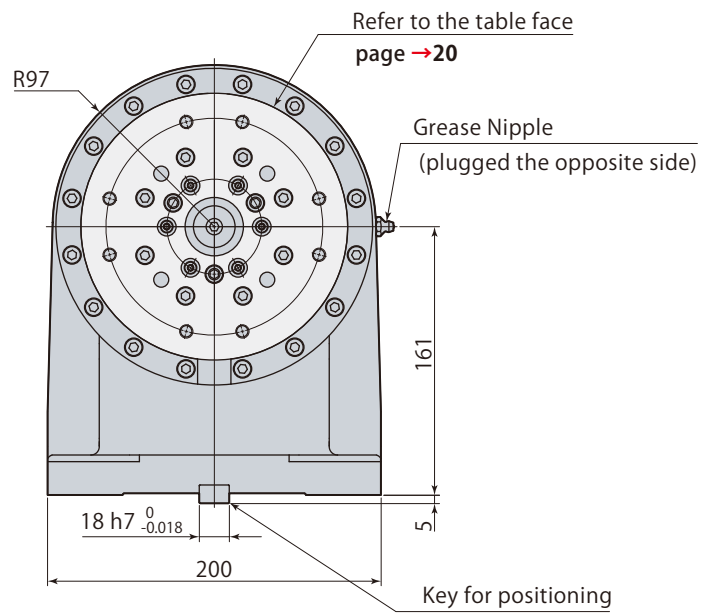
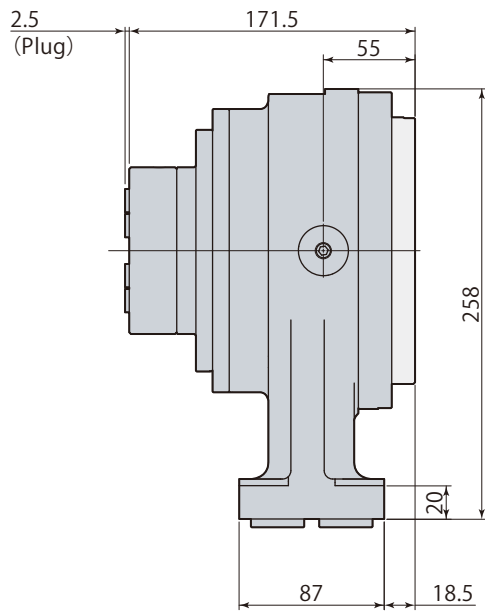
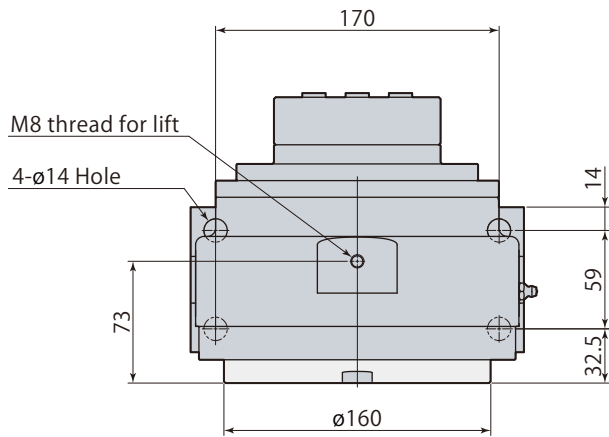

Detail R

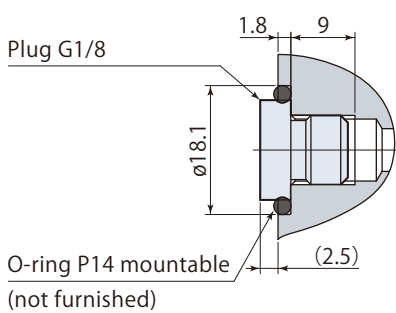

Cutting fluid connection port Rc1/8

Detail R

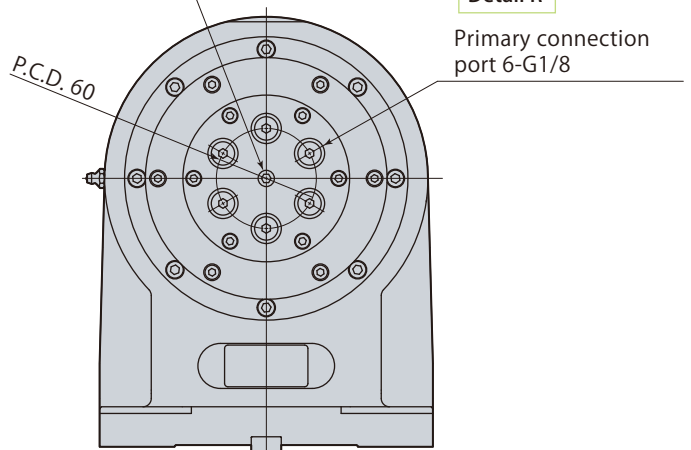

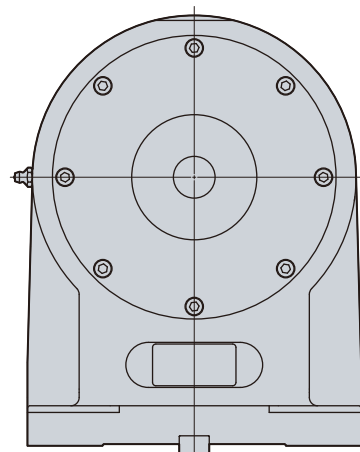
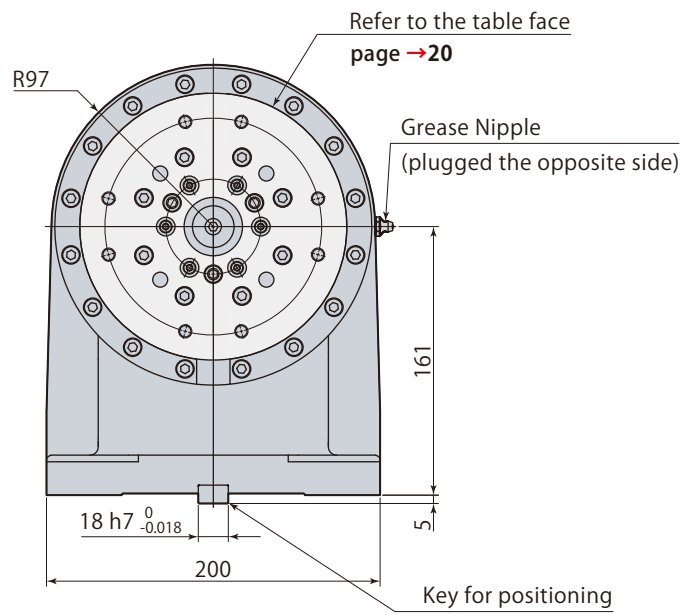
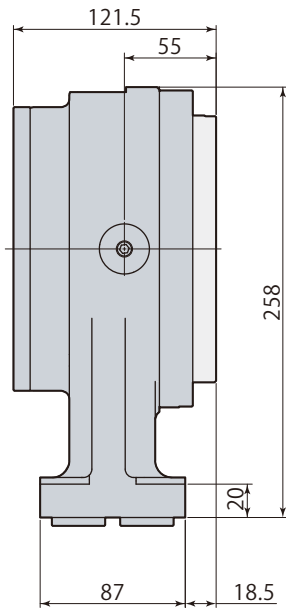
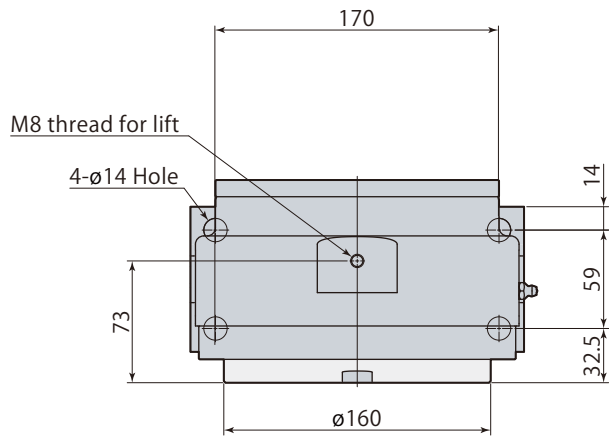

90° Index table face

MDX06 (common)

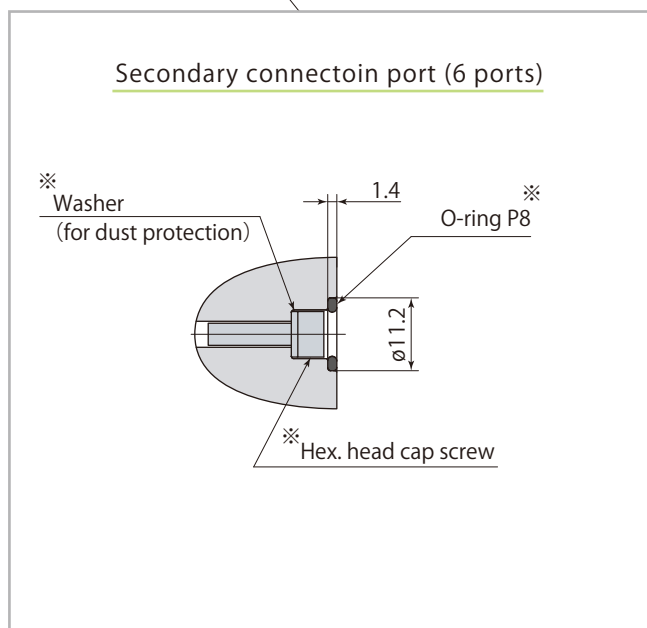
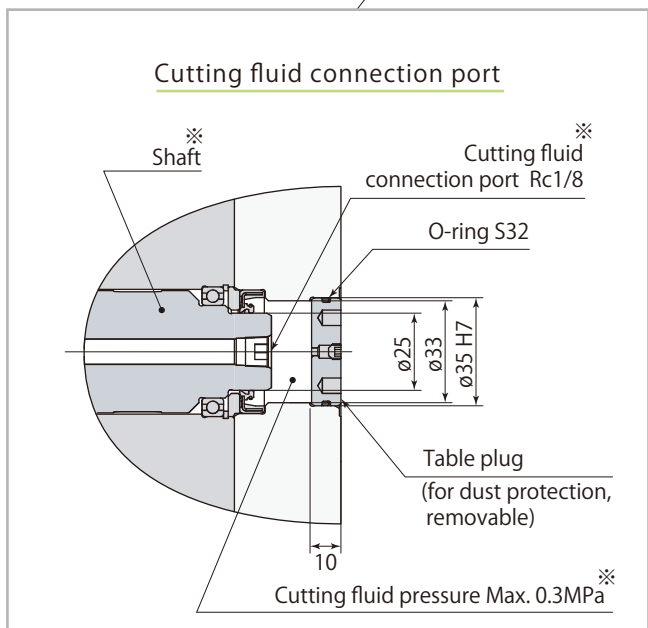
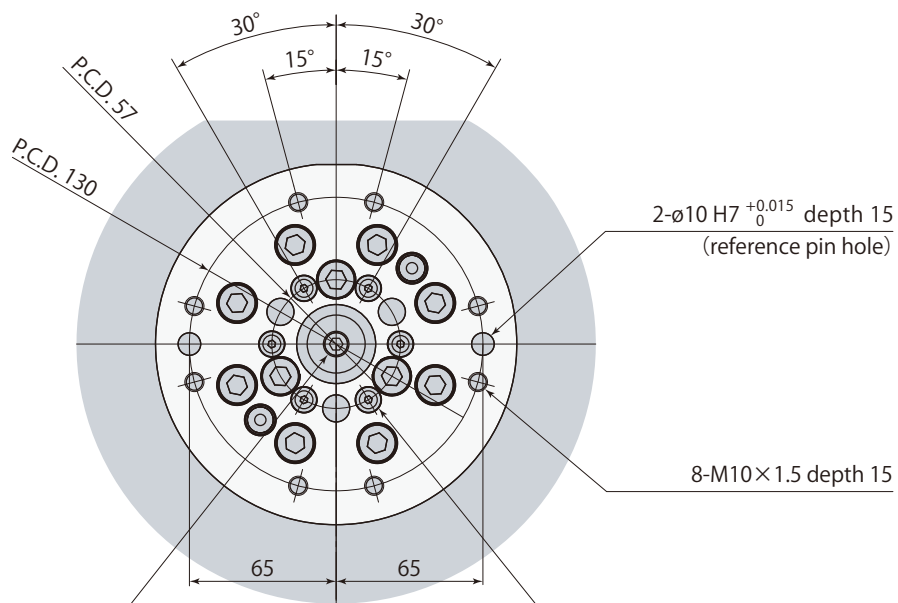

※: Only built-in rotary joint

Support table face

MDS06 (common)

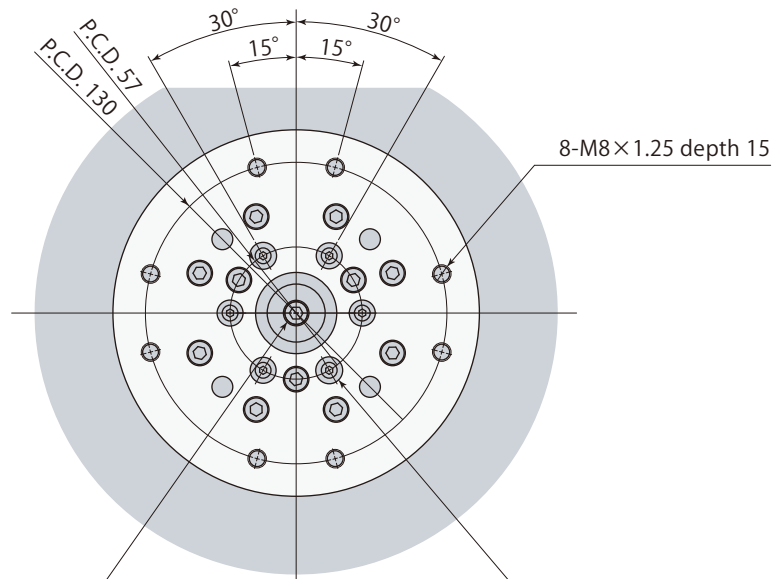

Cutting fluid connection port

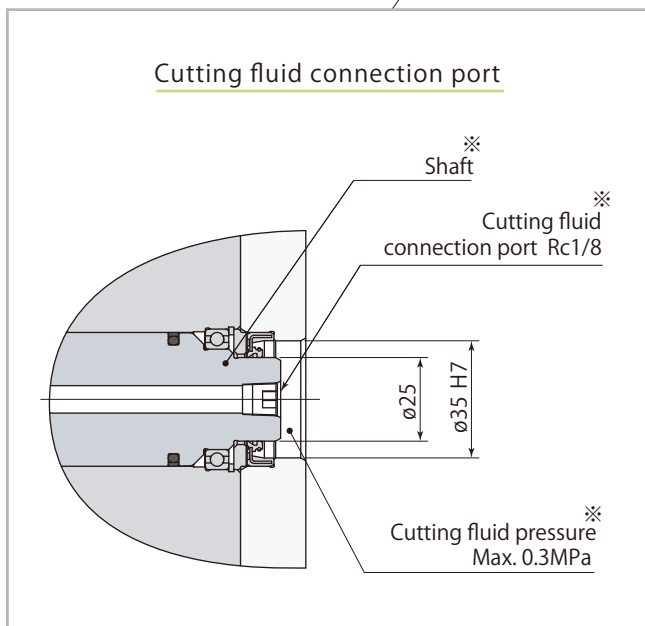

Secondary connectoin port (6 ports)

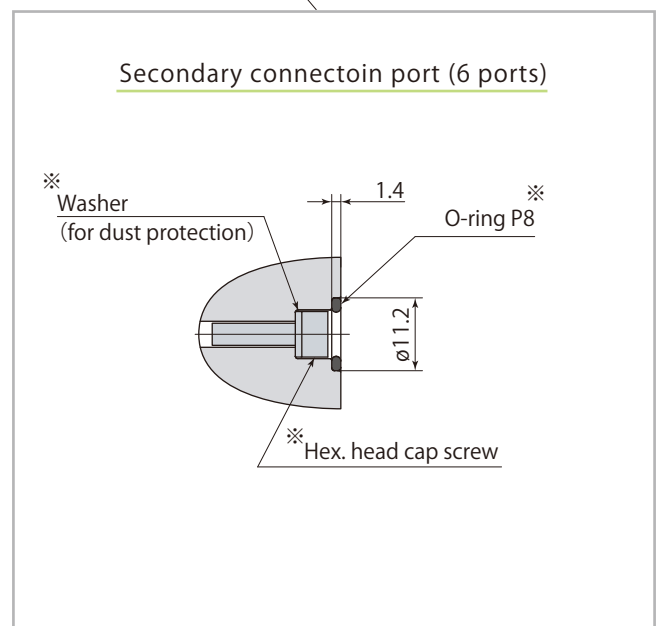

※: Only built-in rotary joint

Motor mounting position

Left : MDX08L-4R

Right : MDX08R-4R

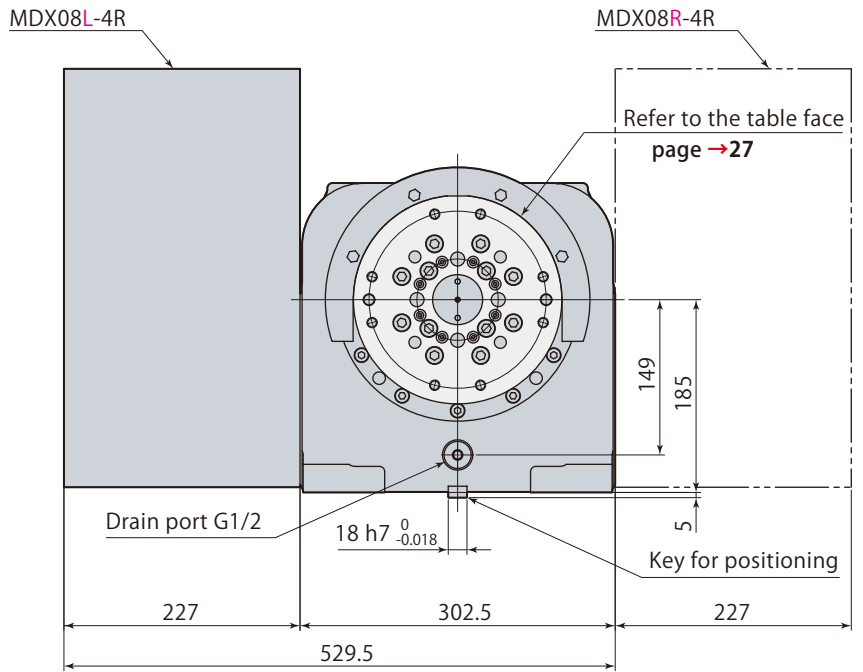
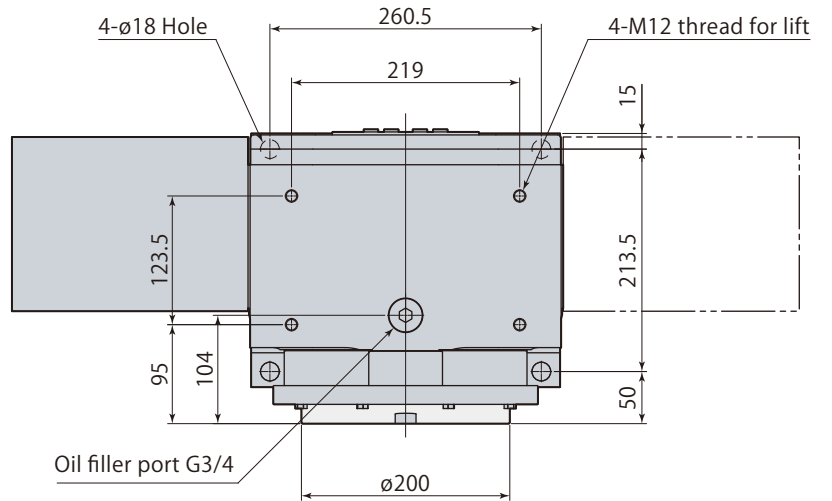

Detail R

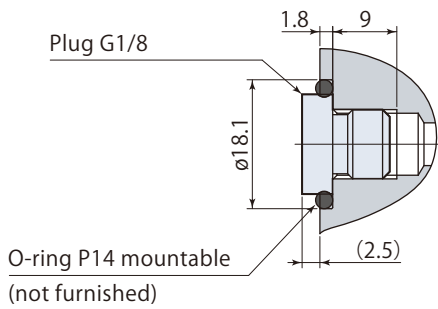

Cutting fluid connection port Rc1/4

Detail R

Primary connection port 8-G1/8

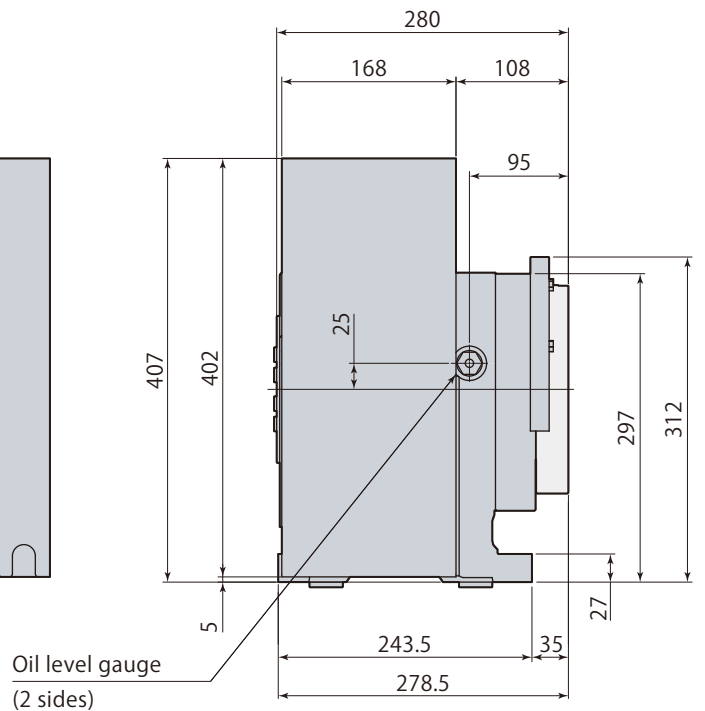
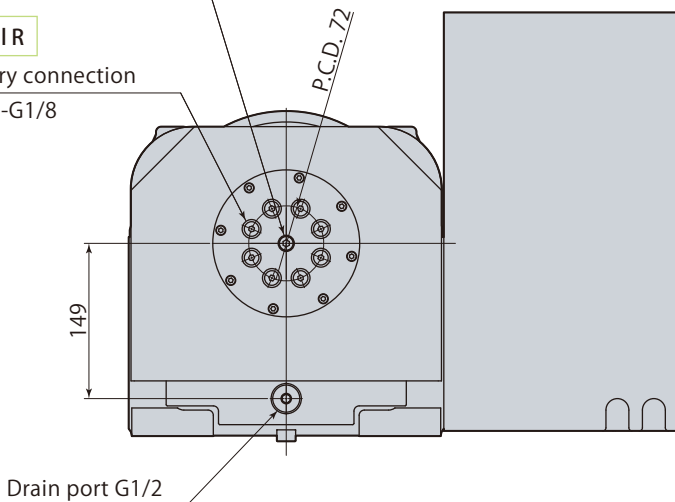

Motor mounting position

Left : MDX08L-4RH

Right : MDX08R-4RH

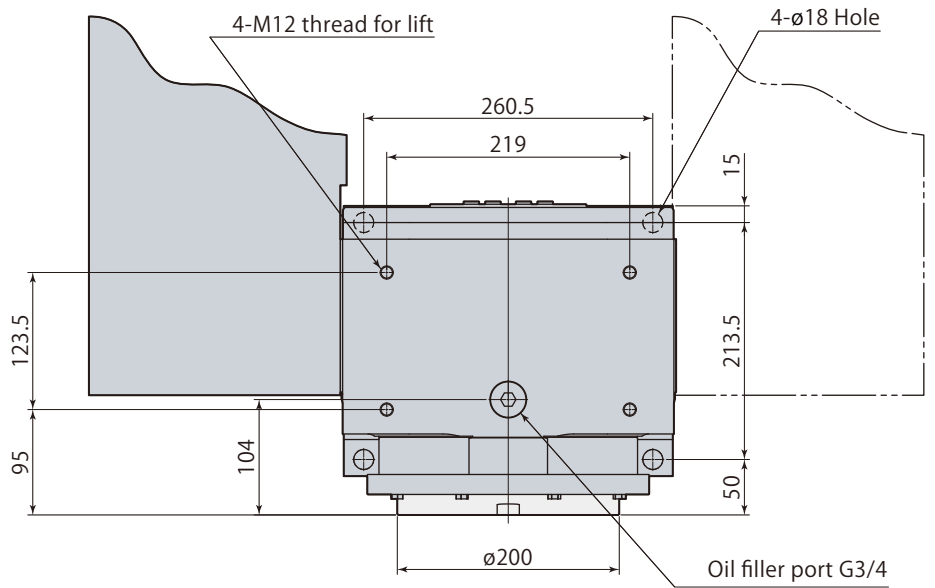

Detail R

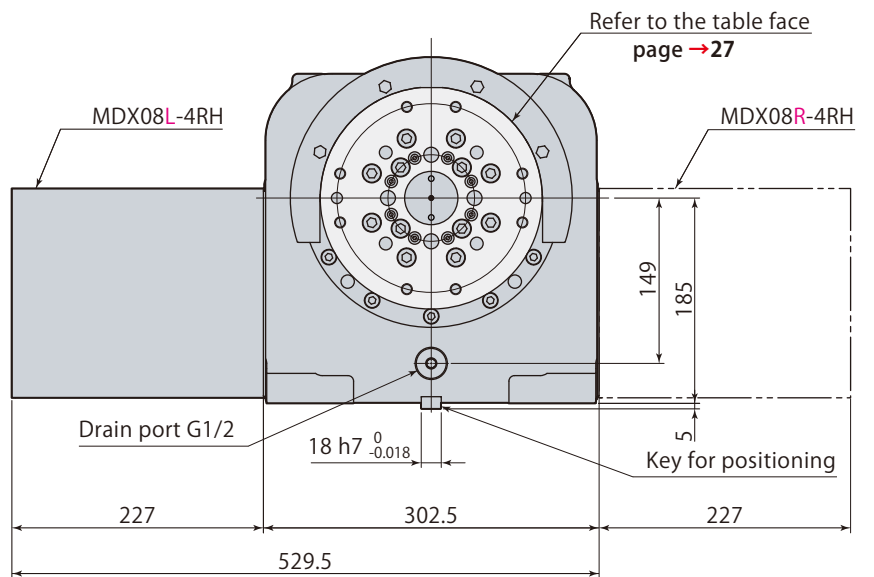
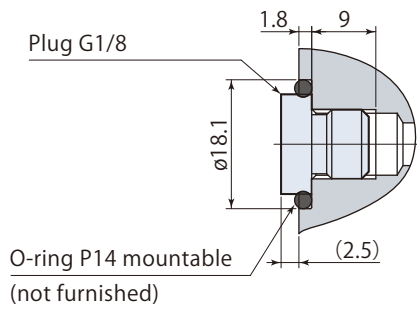

Cutting fluid connection port Rc1/4

Detail R

Primary connection port 8-G1/8

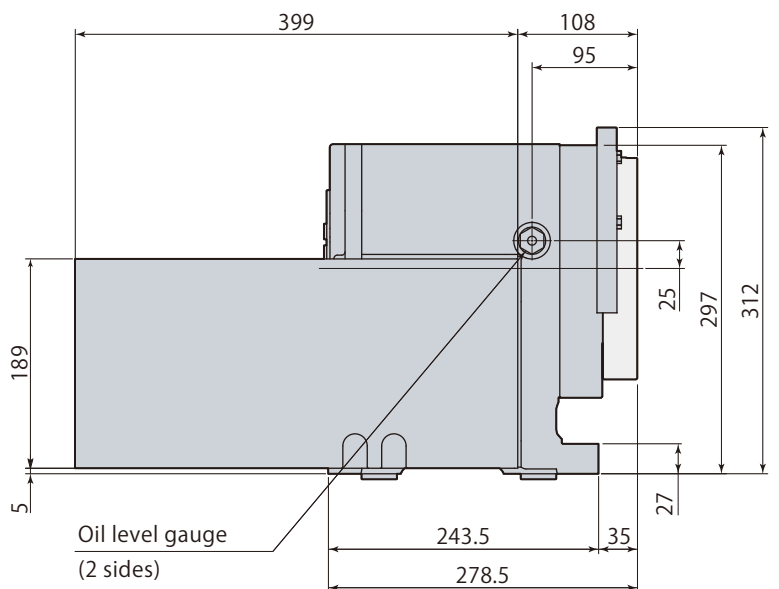
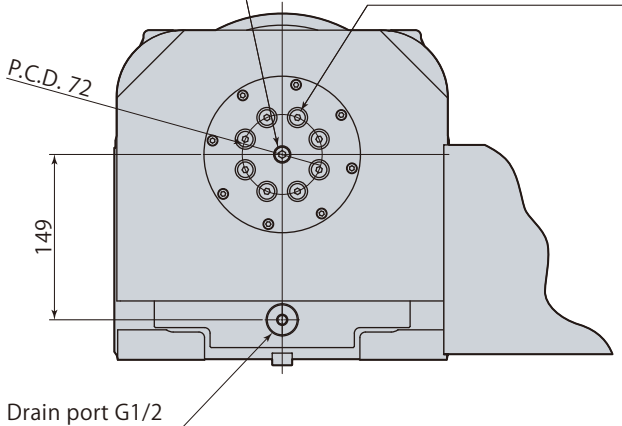

Motor mounting position

Left : MDX08L-4

Right : MDX08R-4

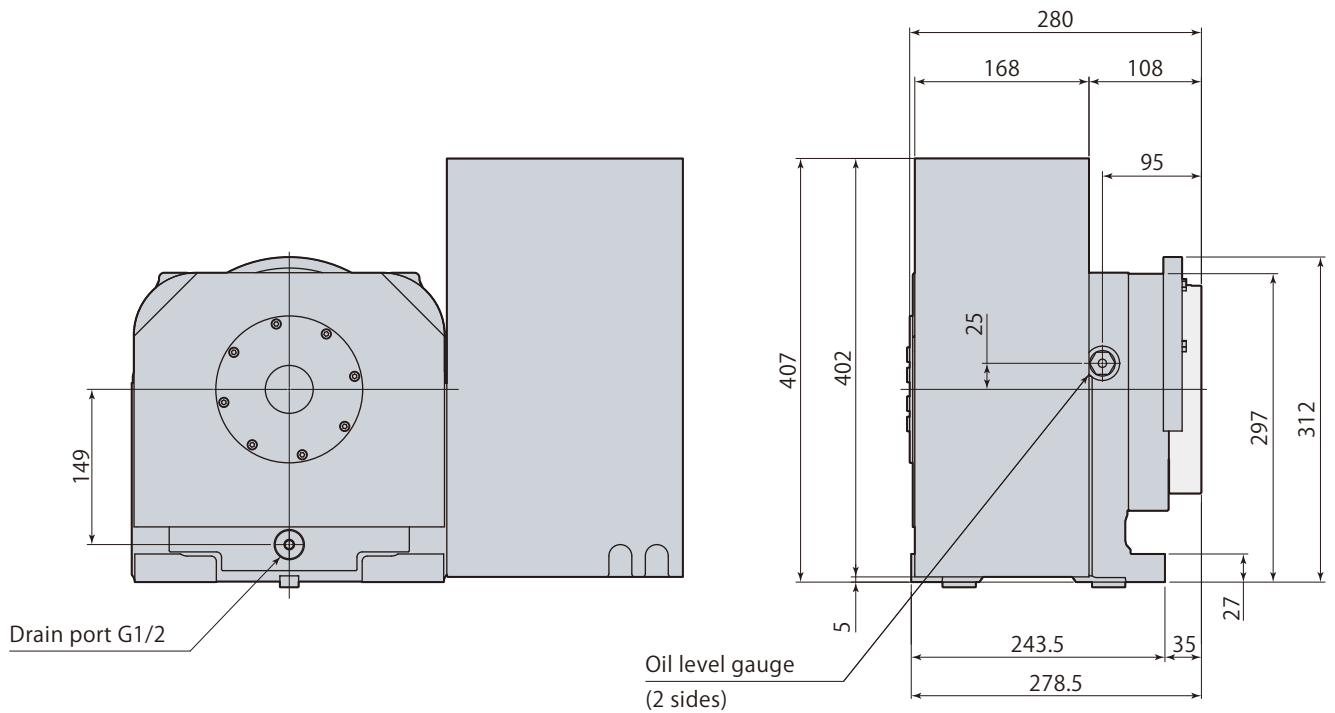
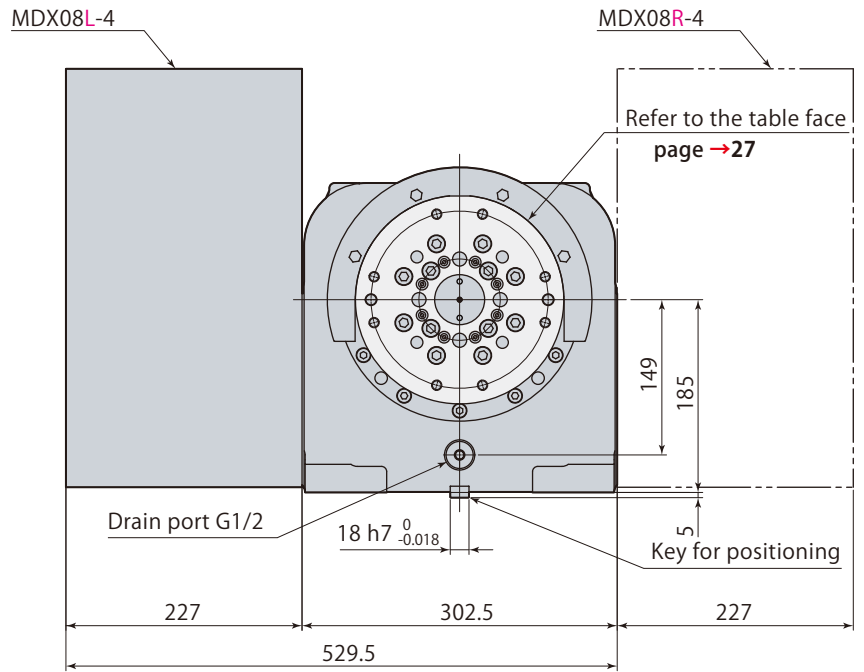
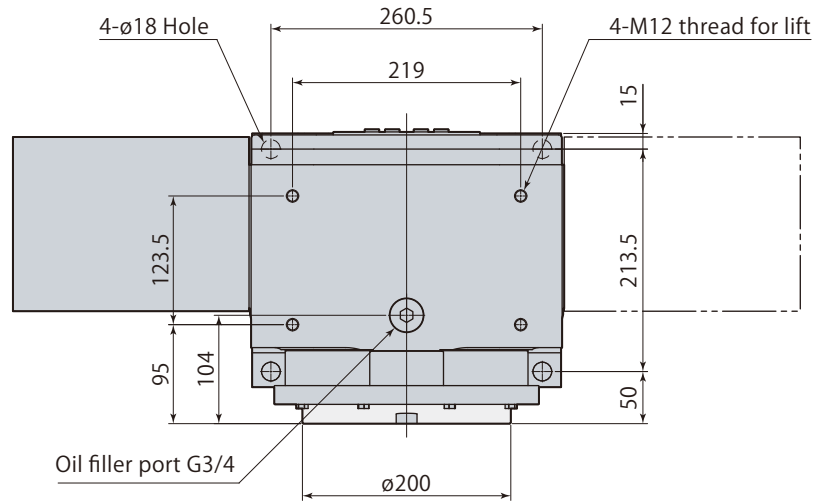

Motor mounting position

Left : MDX08L-4H

Right : MDX08R-4H

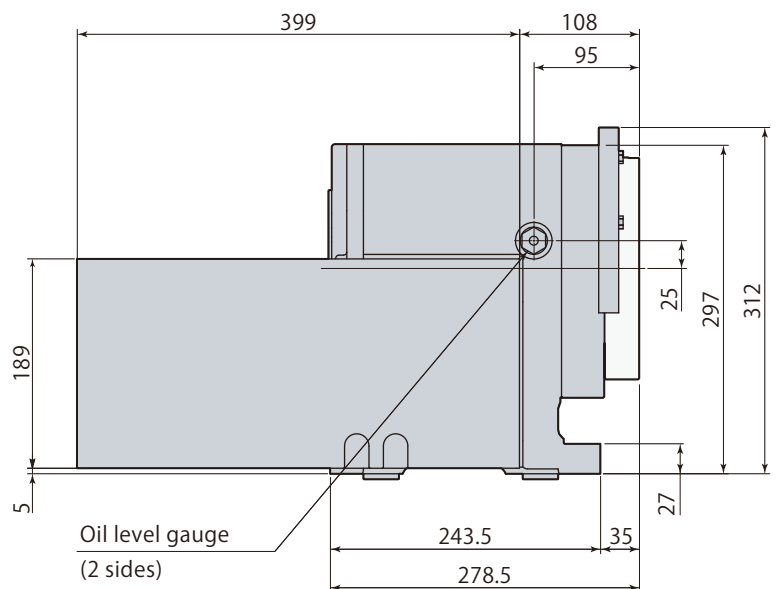
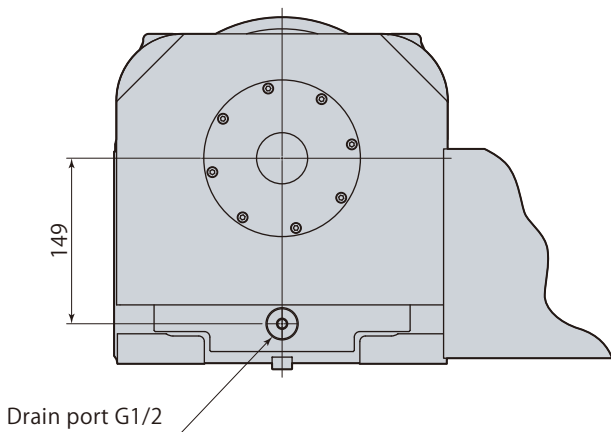
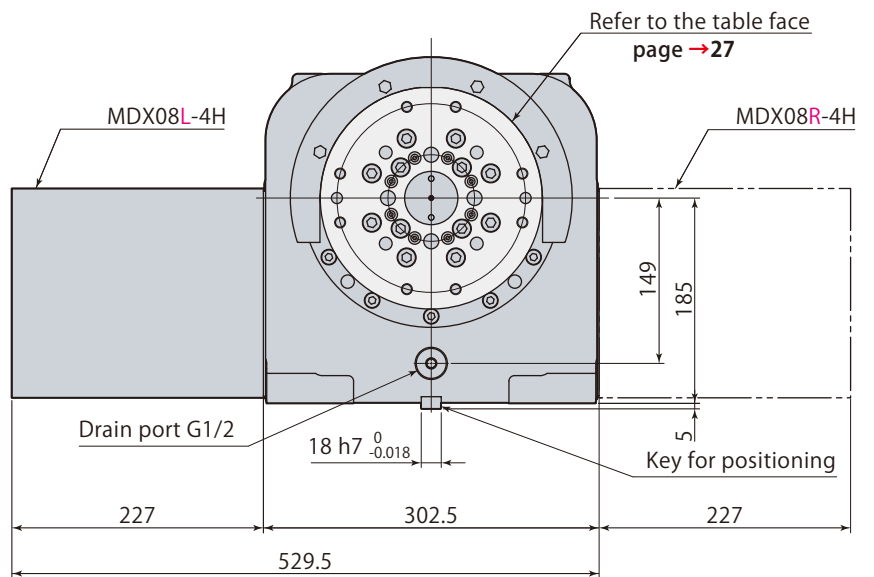
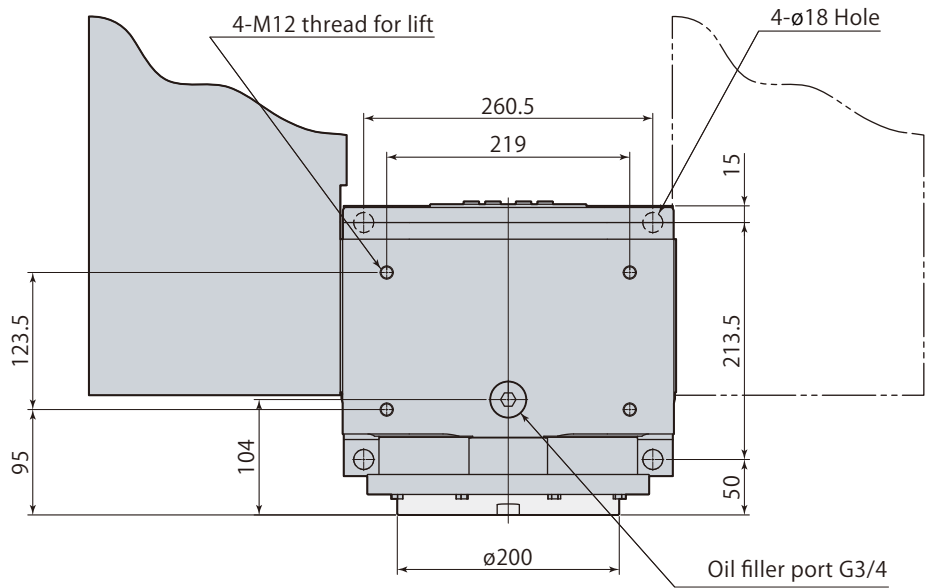

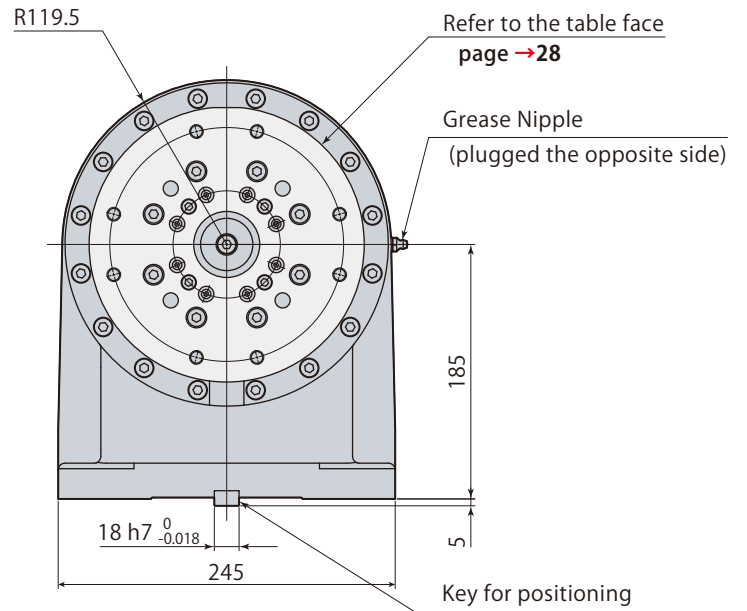
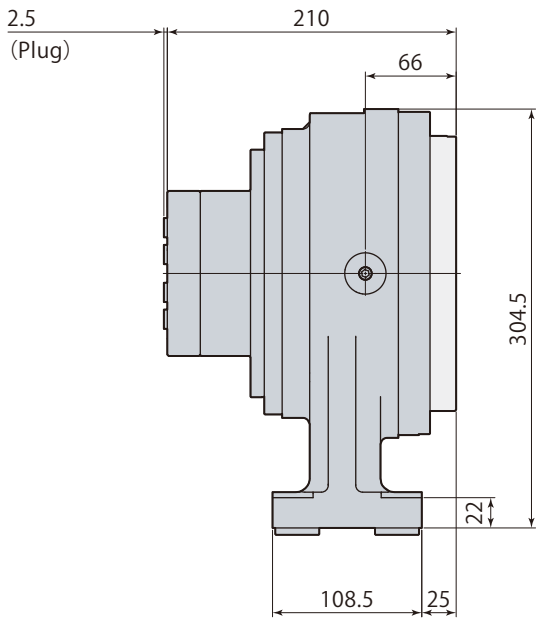
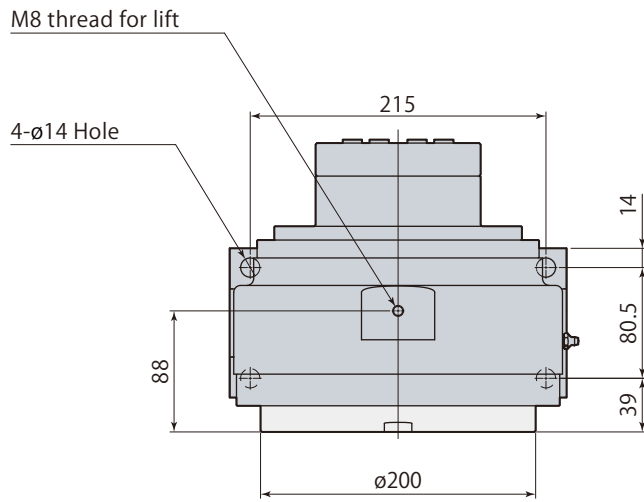

Detail R

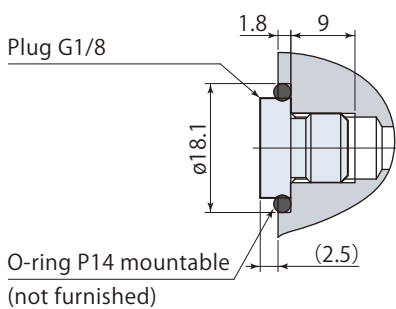

Detail R

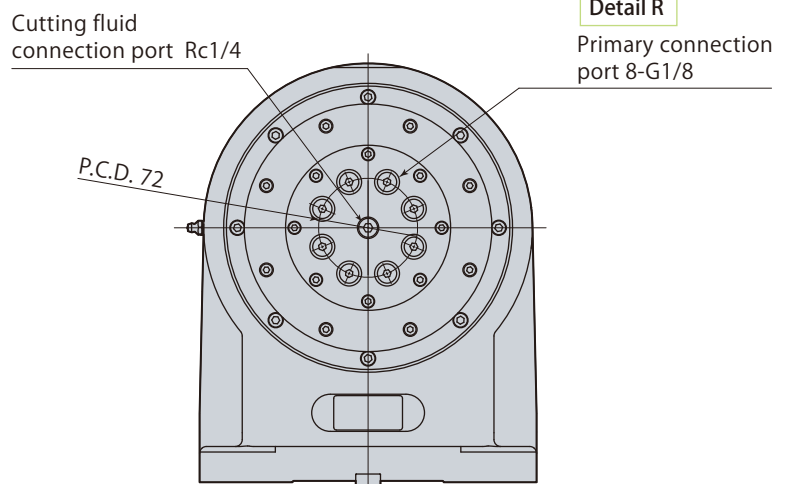

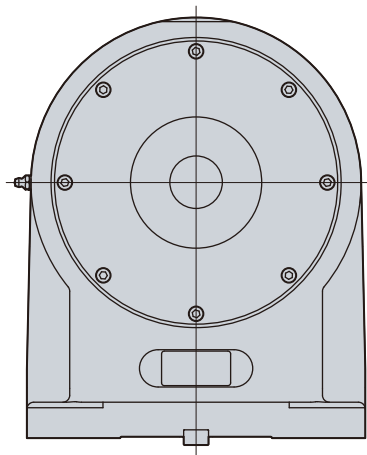
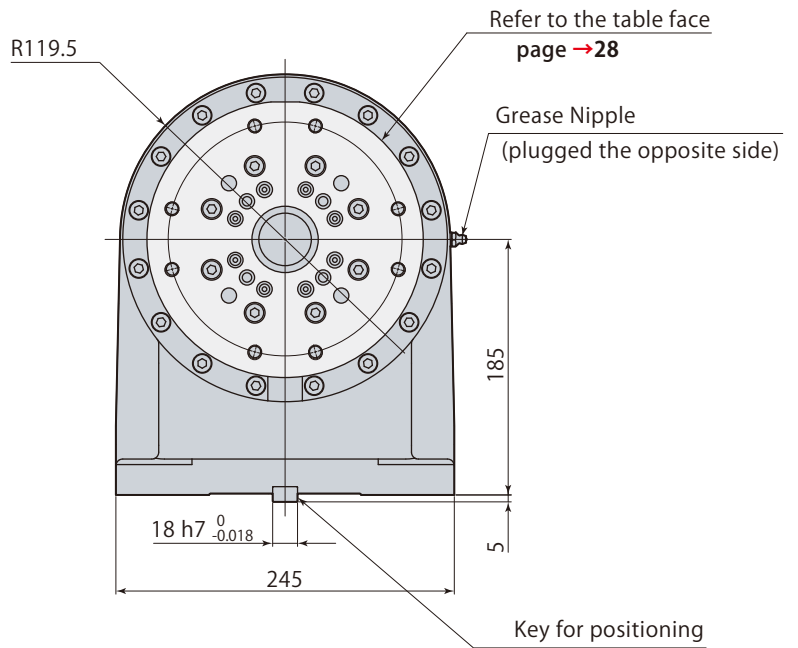
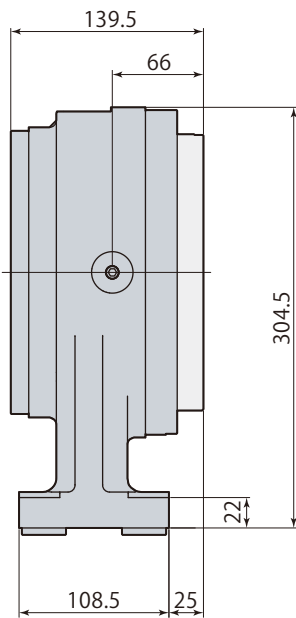
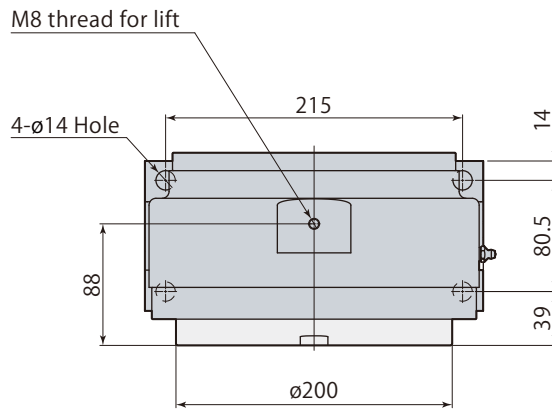

90° Index table face

MDX08 (common)

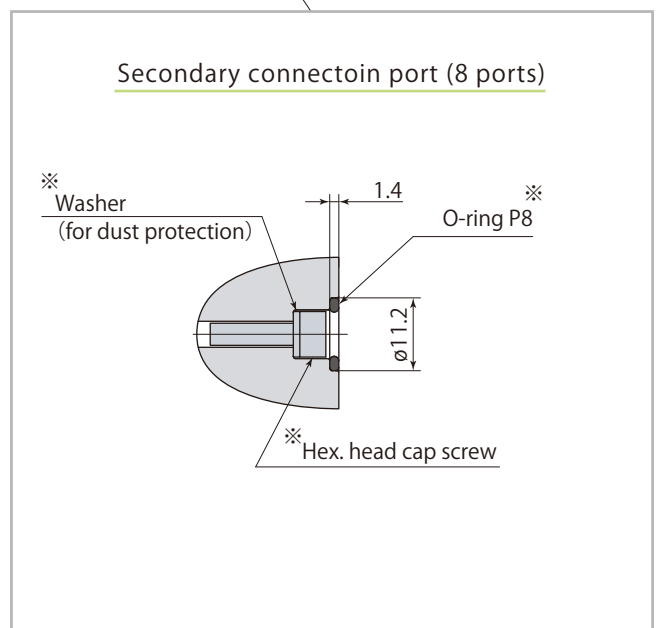
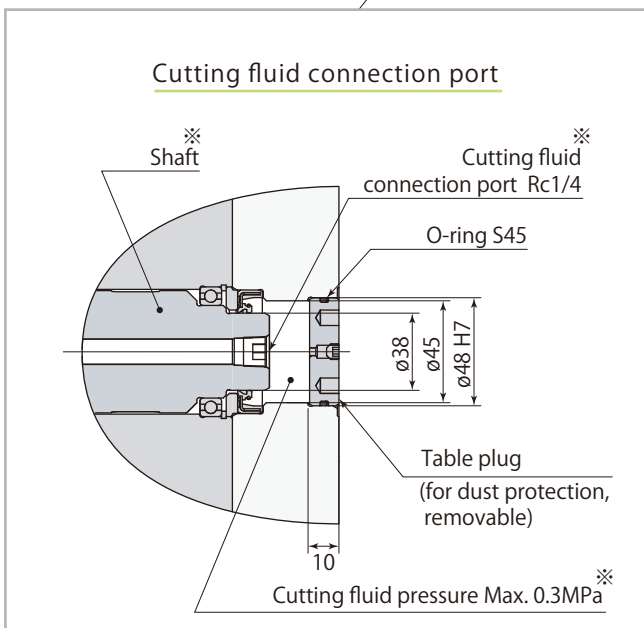
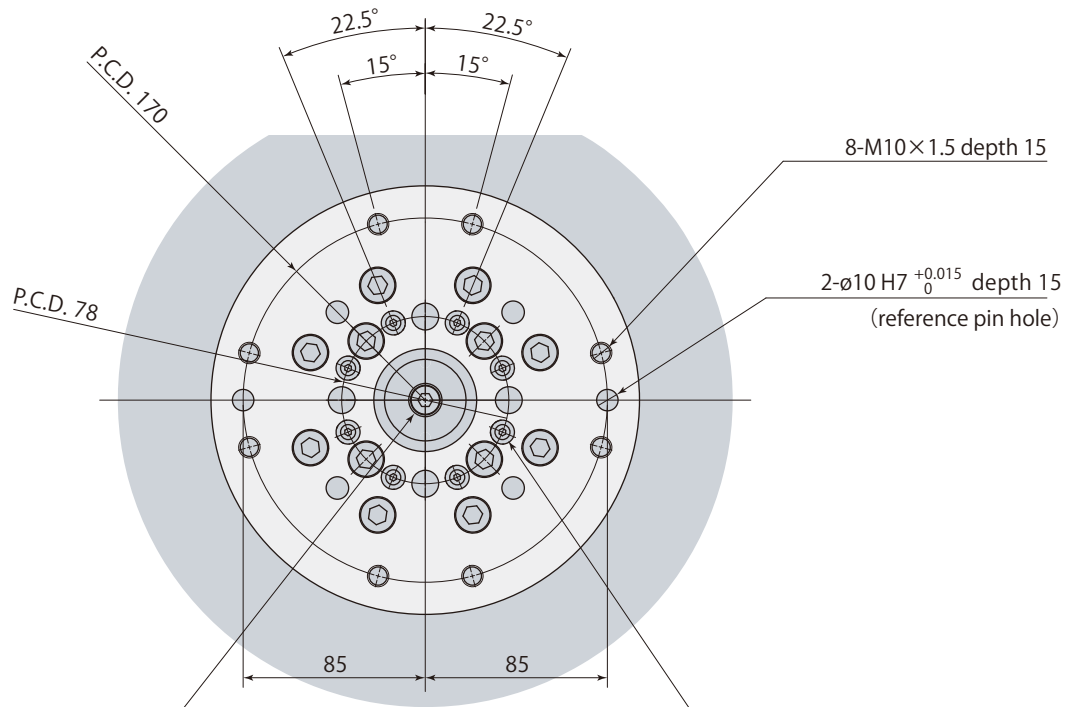

※: Only built-in rotary joint

Support table face

MDS08 (common)

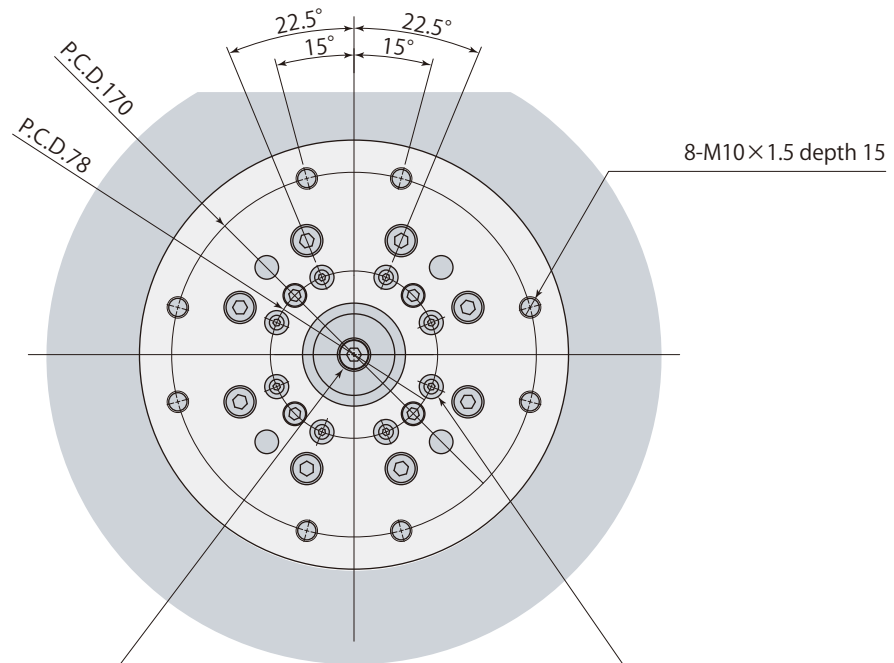

Cutting fluid connection port

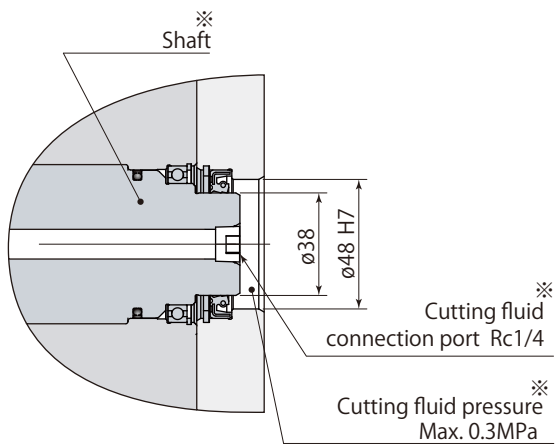

Secondary connectoin port (8 ports)

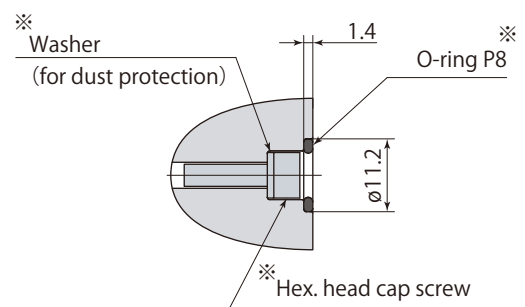

※ : Only built-in rotary joint

A jig integrating with expansion clamps for mass-produced parts.

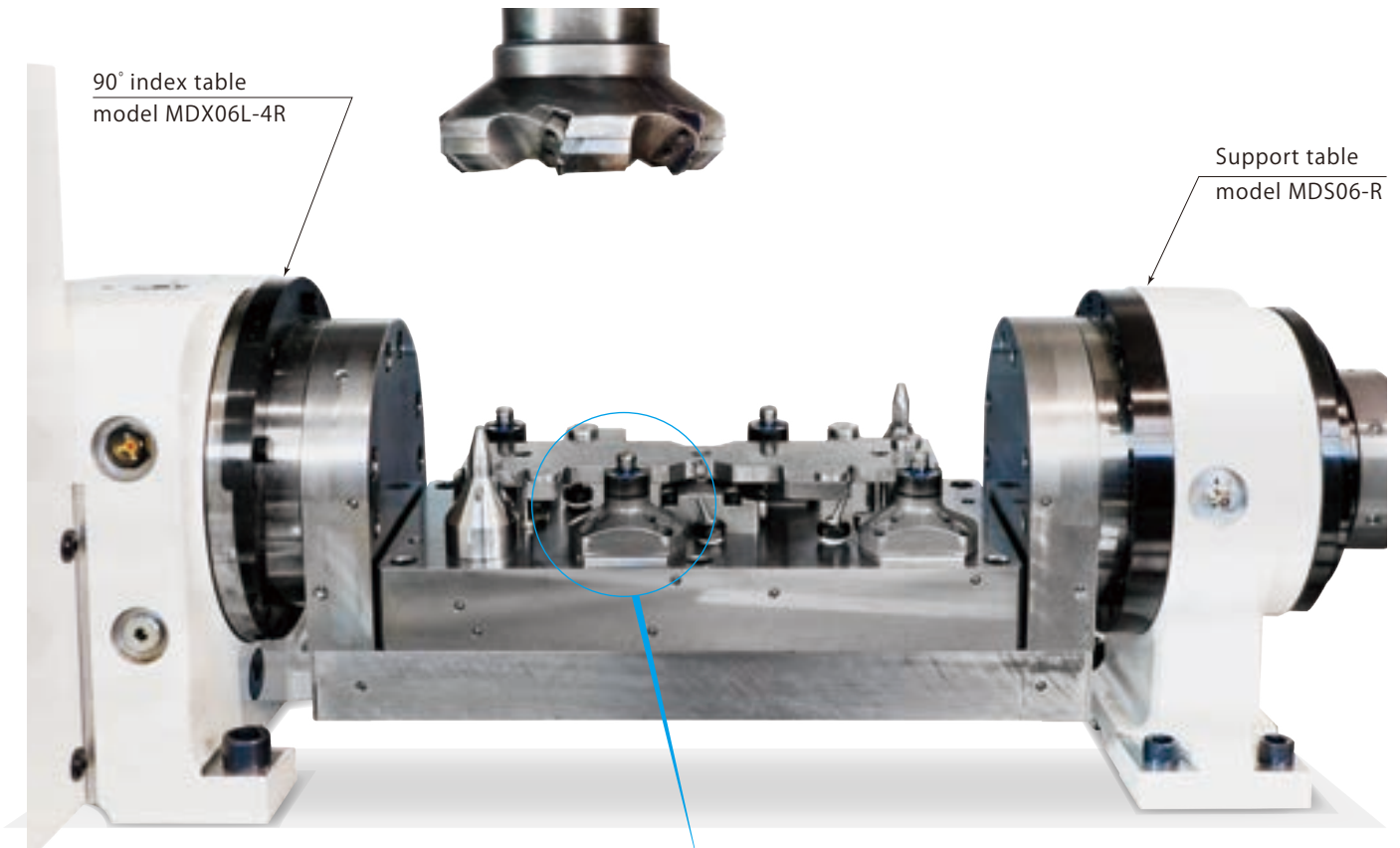

Expansion clamp

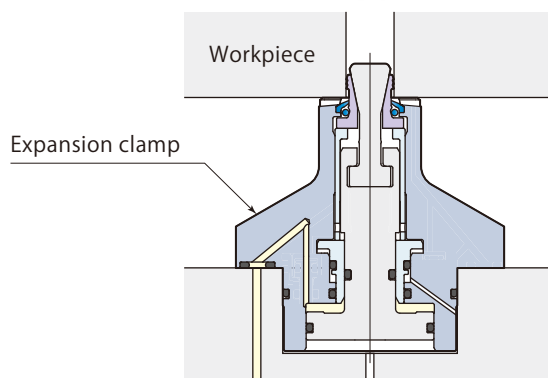

4 sides machining in a small space

90° index table
model MDX08L-4R

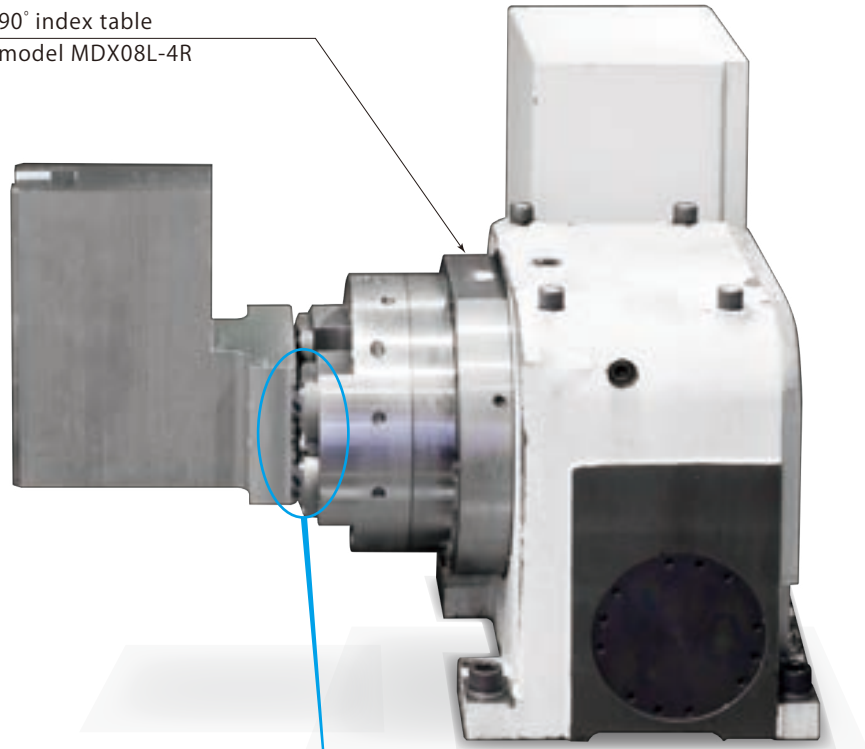

Expansion clamp

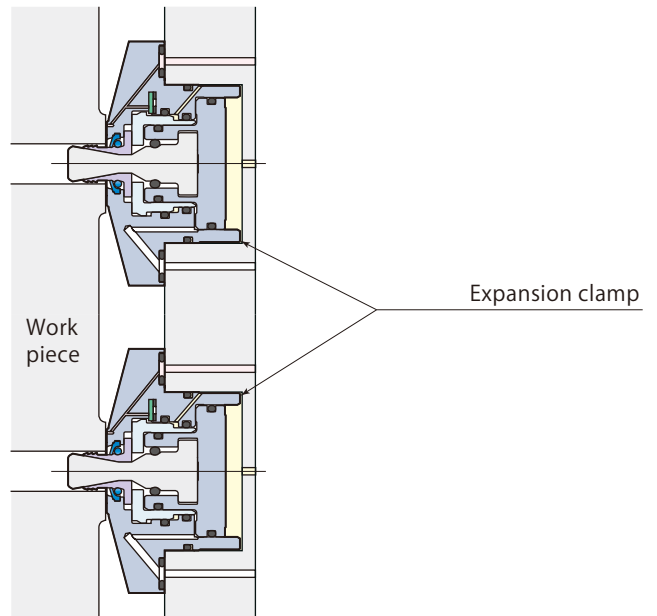

5-side machining jig integrating with Pal coupling

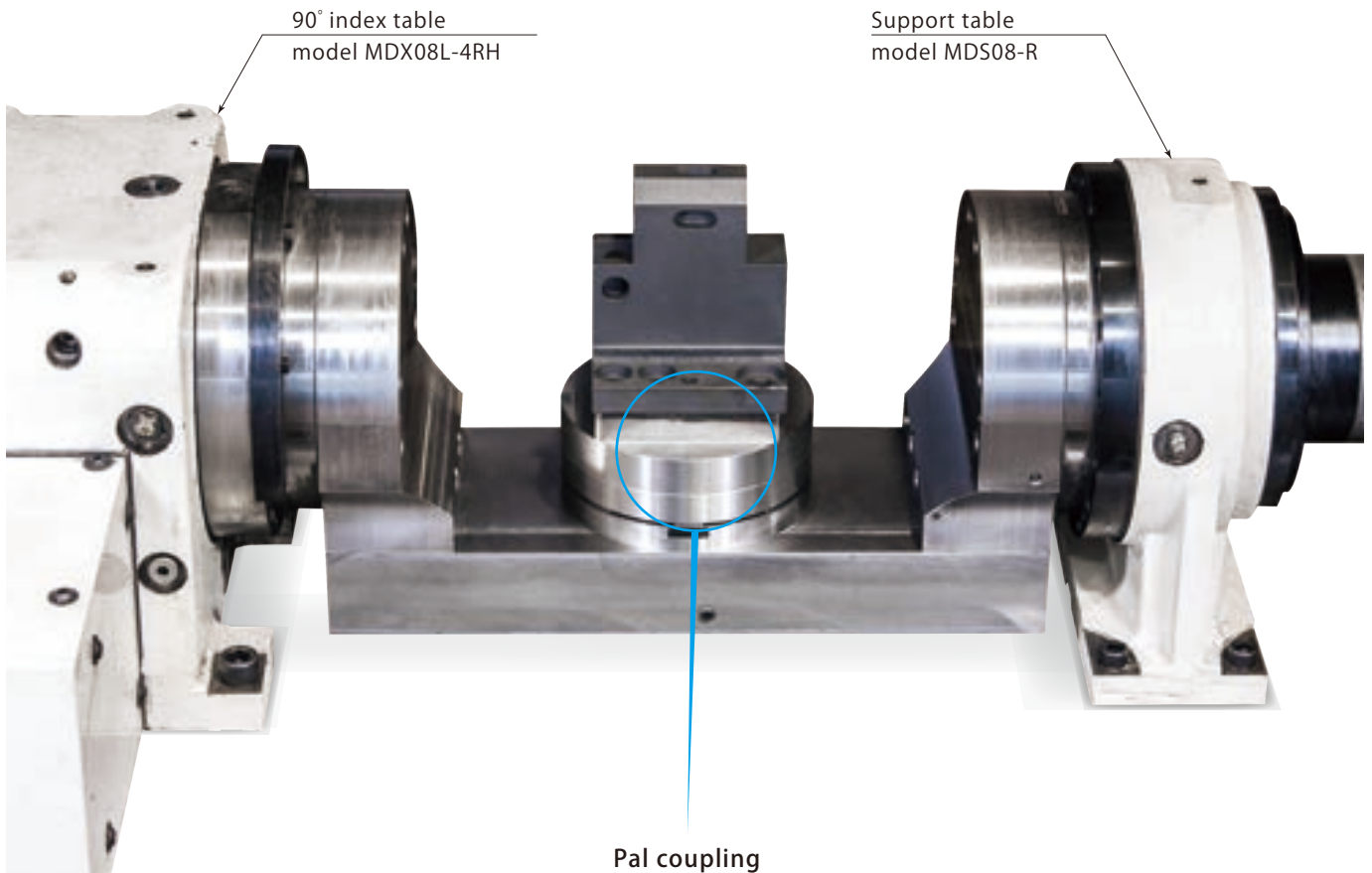

Pal coupling

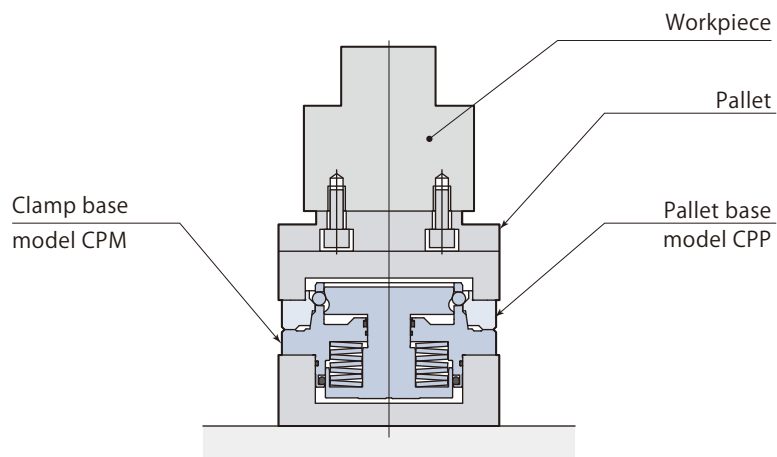

2nd machining after turning

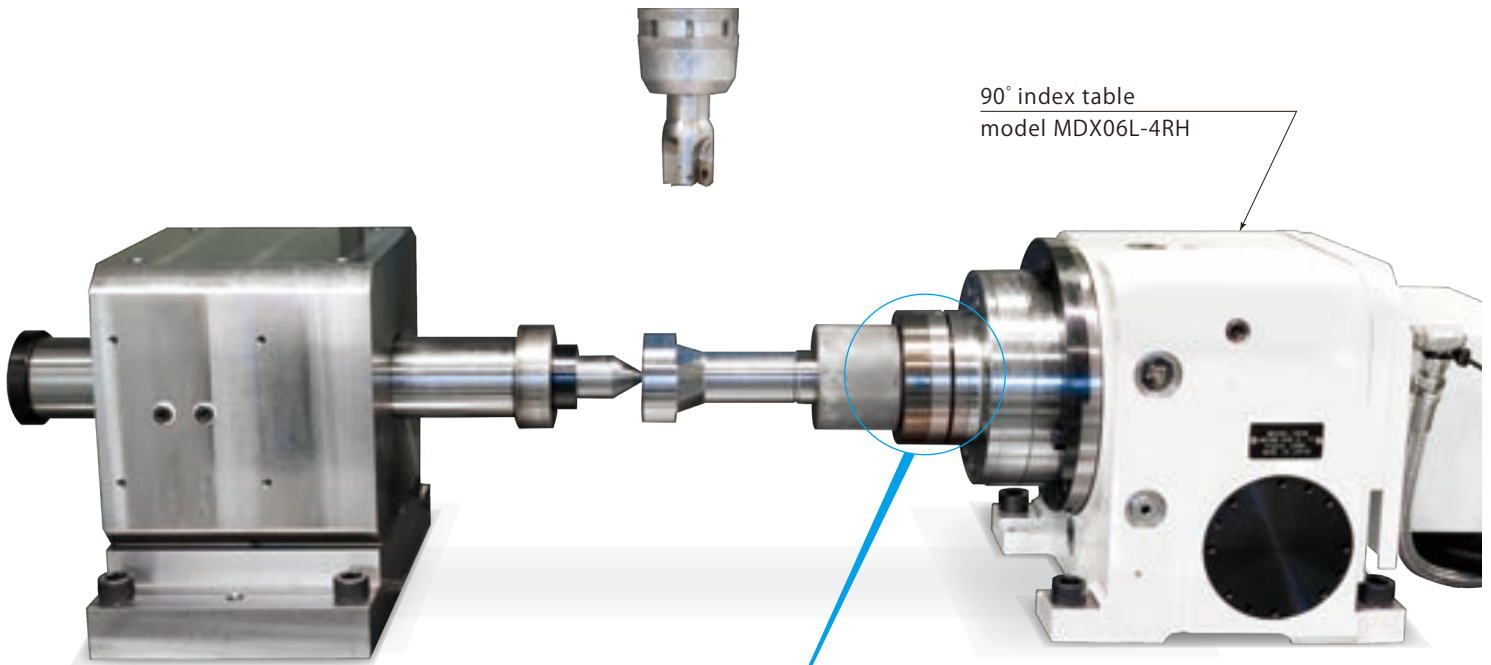

Pal coupling

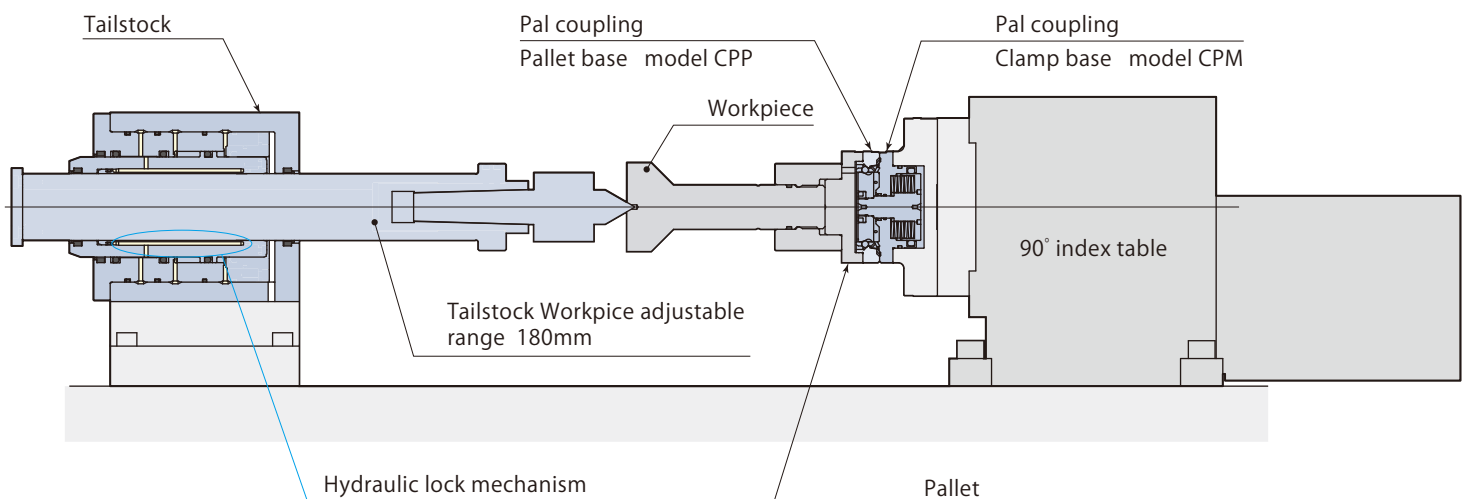
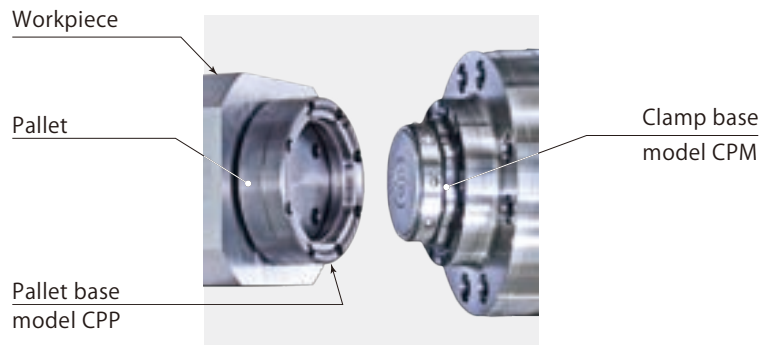

A jig for variety of workpiece integrating with a hydraulic centering vise

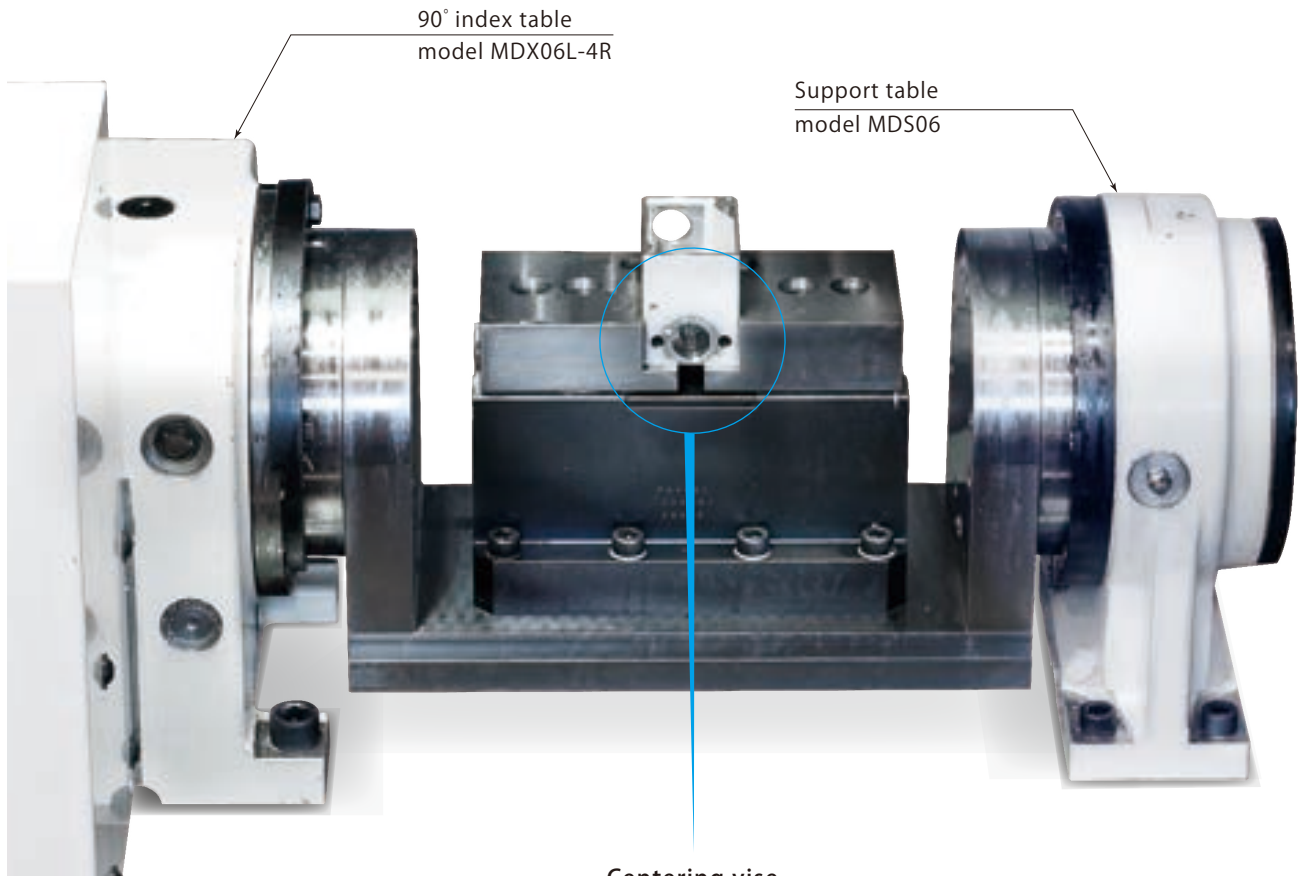

Centering vise

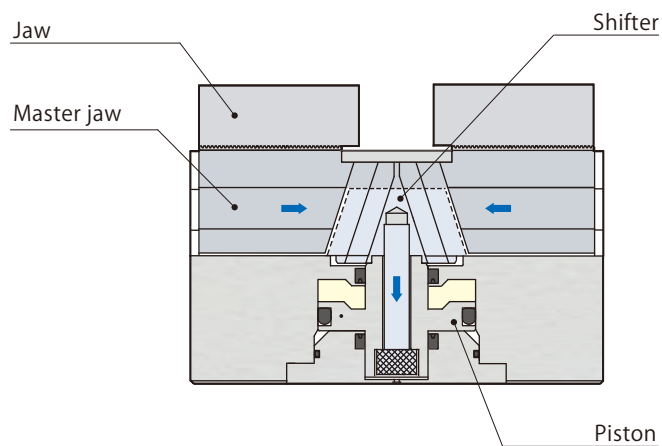

Multi-face machining for a long workpiece

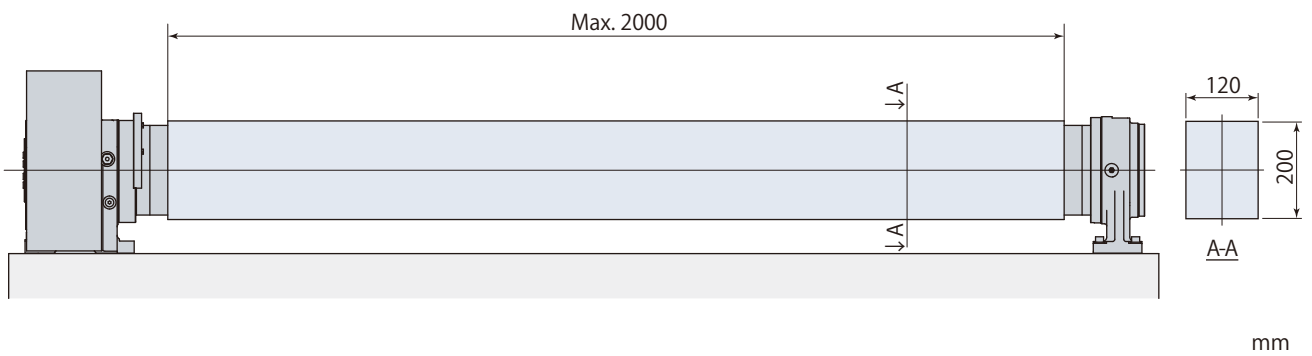
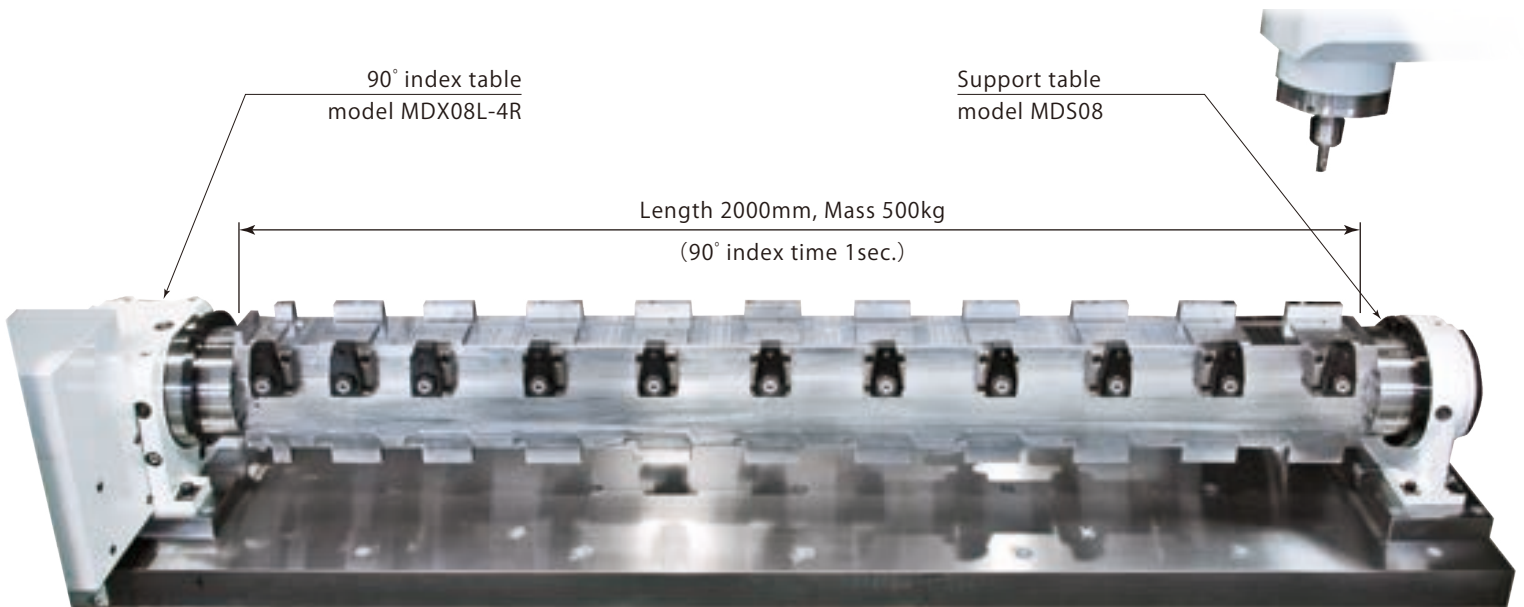

Pascal

Itami, Hyogo, Japan 664-8502
TEL. 072-777-3333 FAX. 072-777-3520



CERTIFICATE OF APPROVAL ISO9001