

Pascal

Stamping die clamping system





Pascal clamp model **TXA**

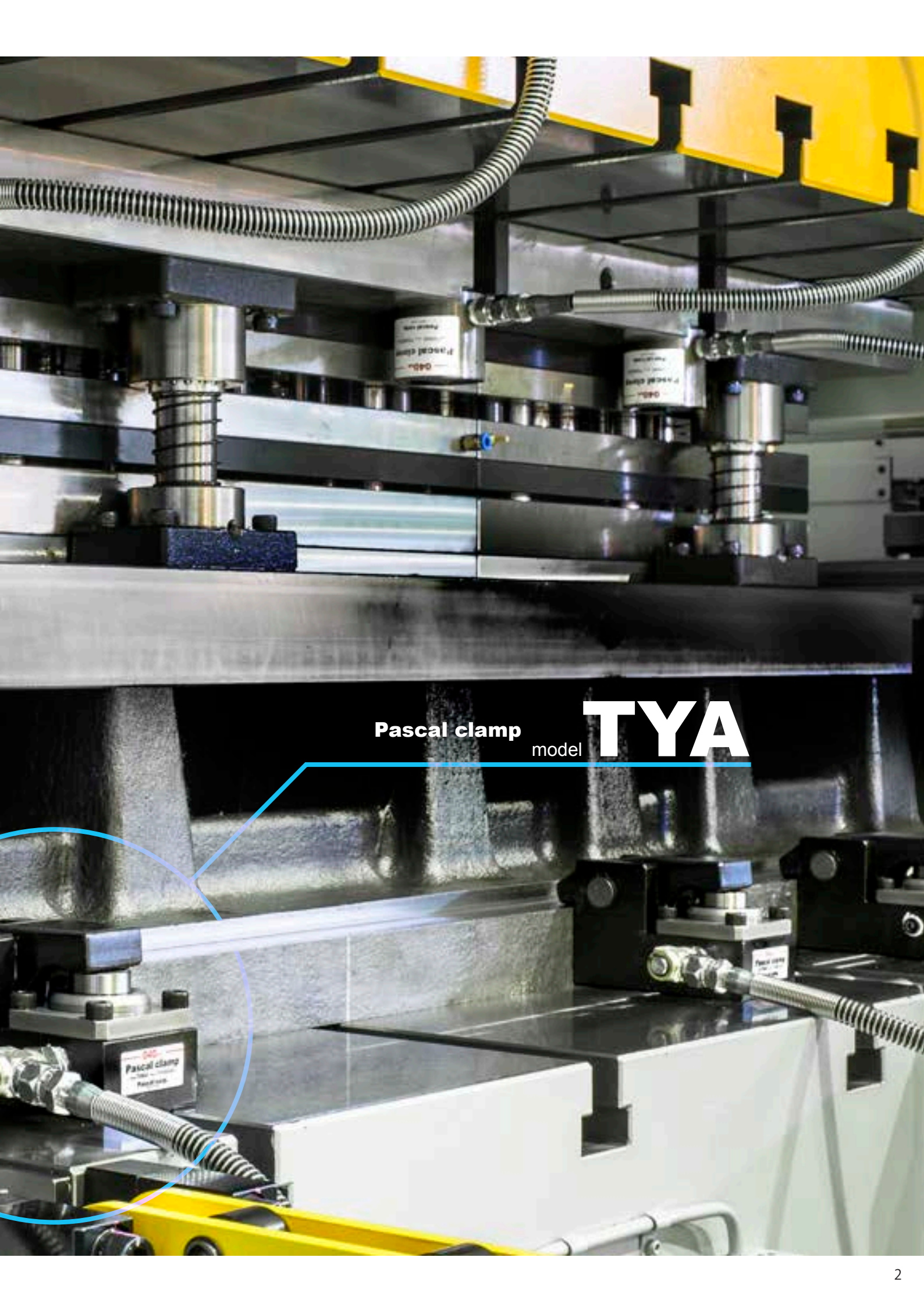

Pascal clamp model **TYA**



Die-lifter
model

DLF

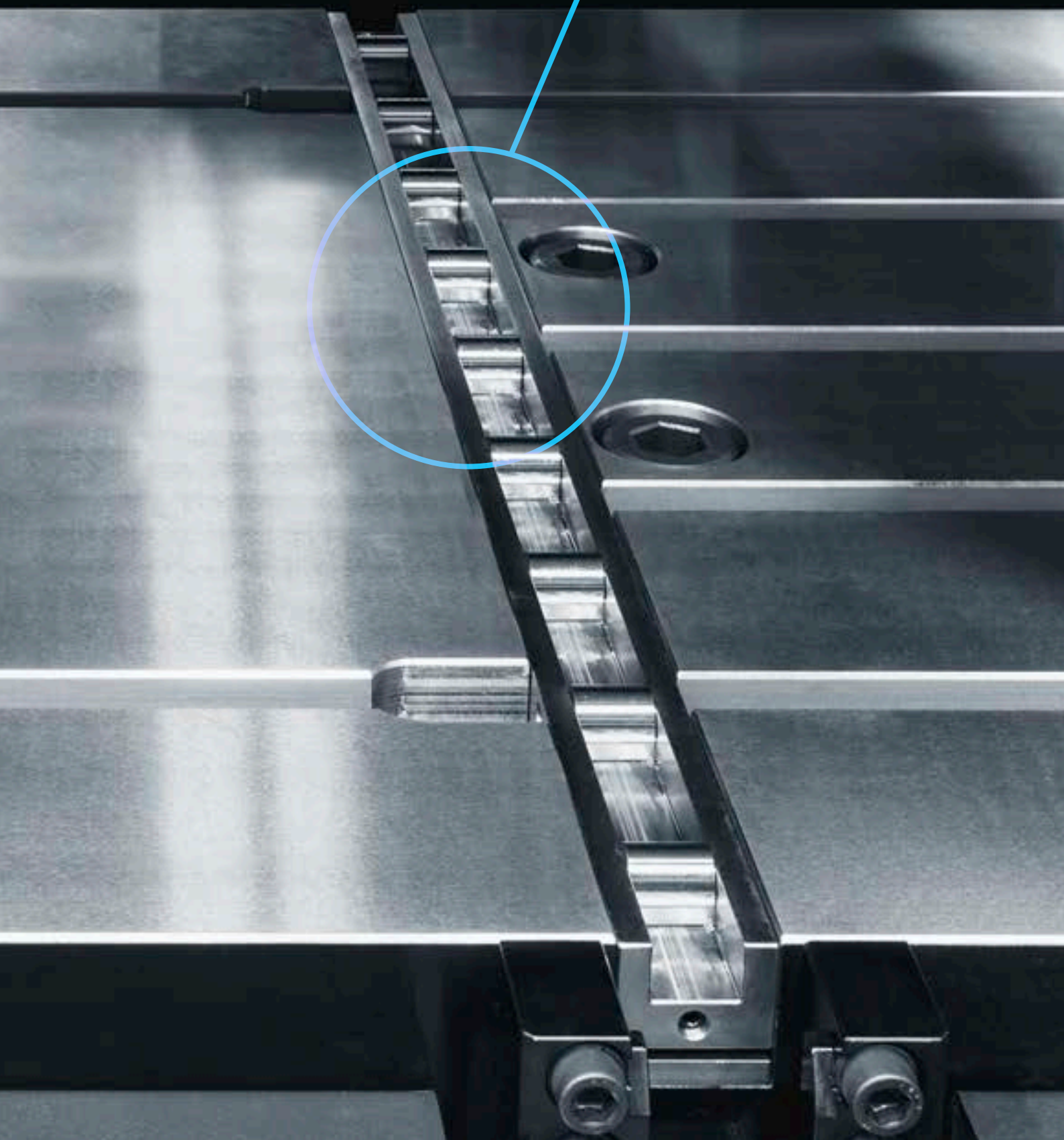



traveling clamp TRX

5,000kN press



Pre-roller stand PRM

20,000kN press







traveling clamp

30,000kN press







Press mag clamp

2,000kN High velocity press

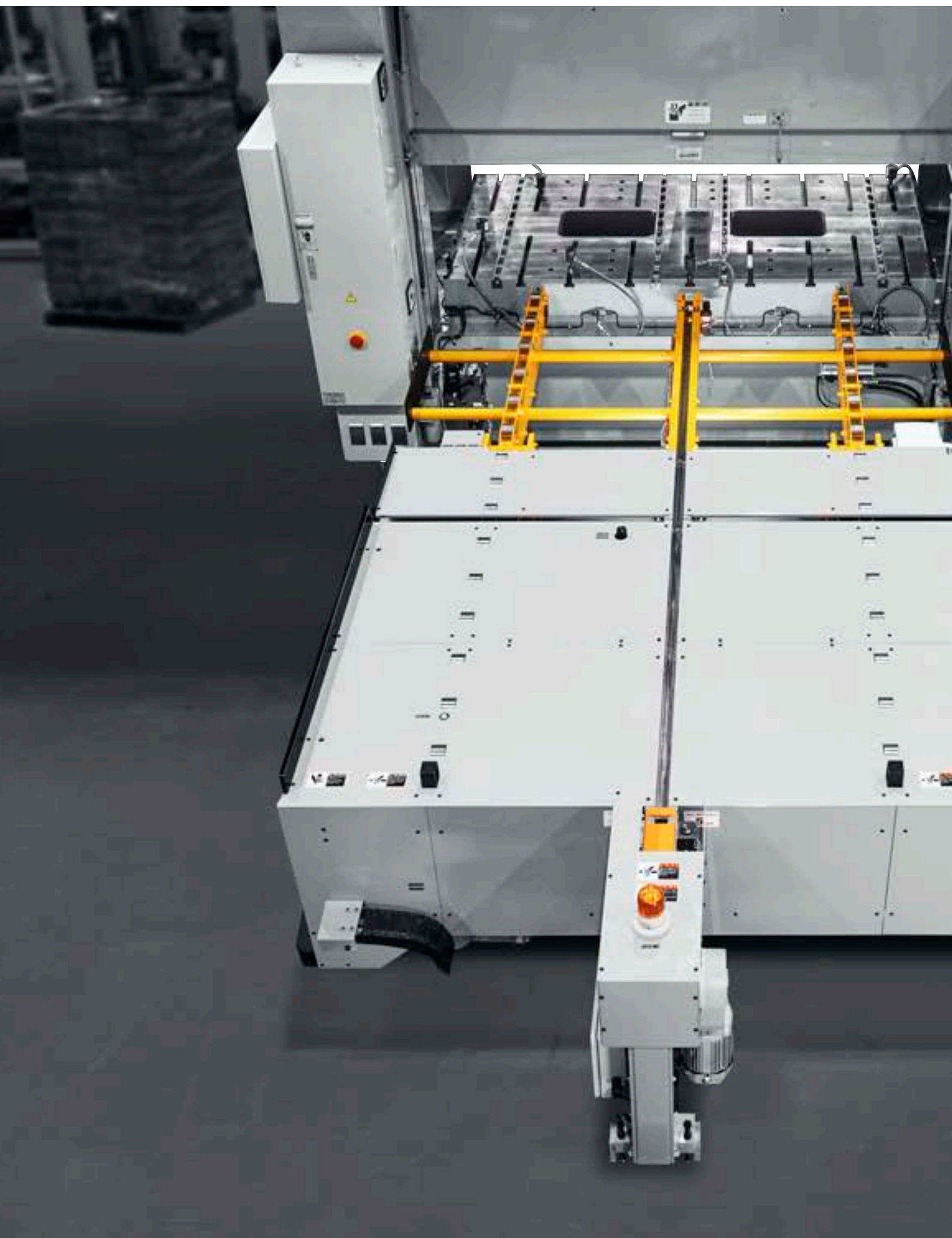

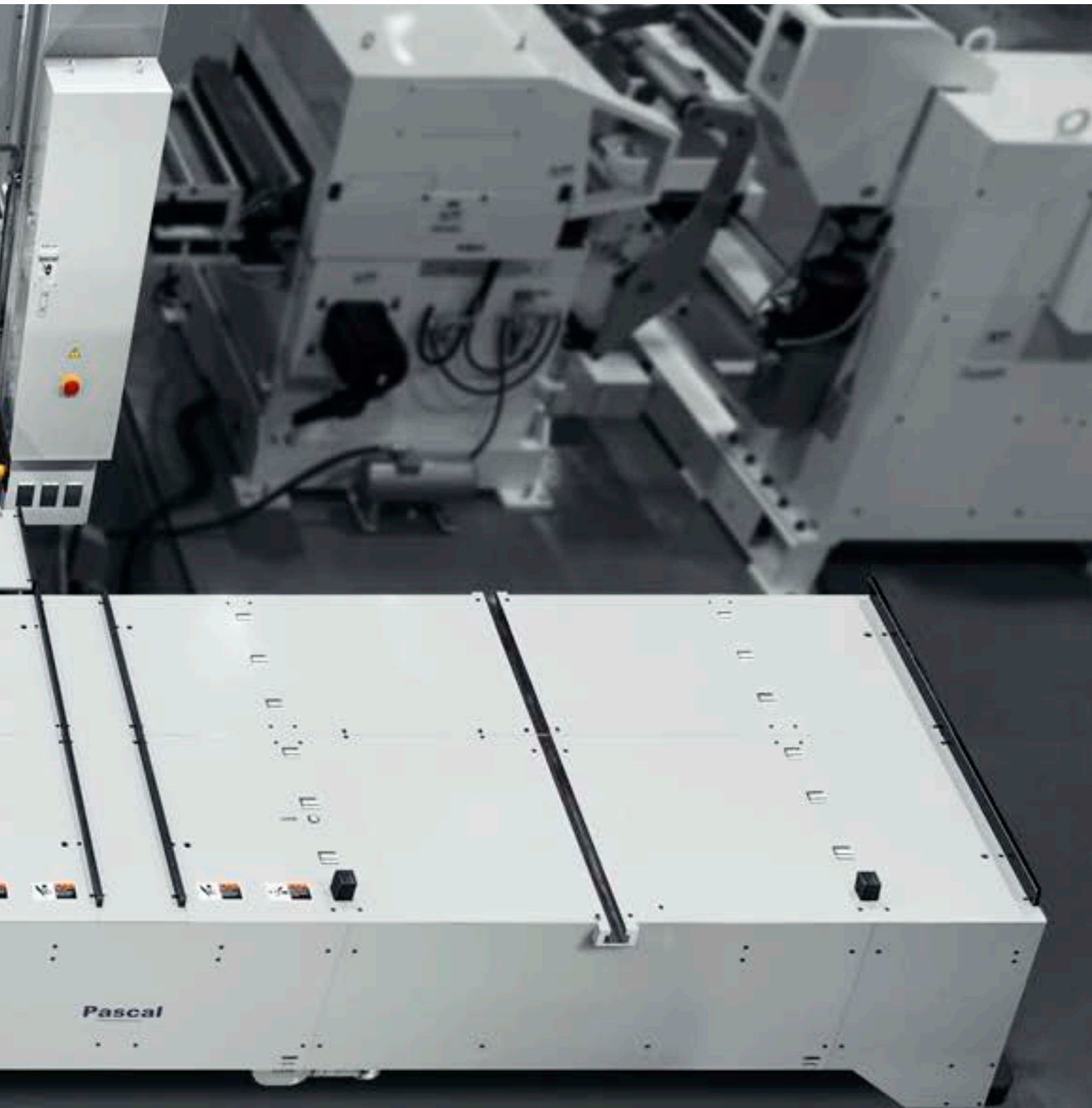

Stamping die changer

3,000kN press

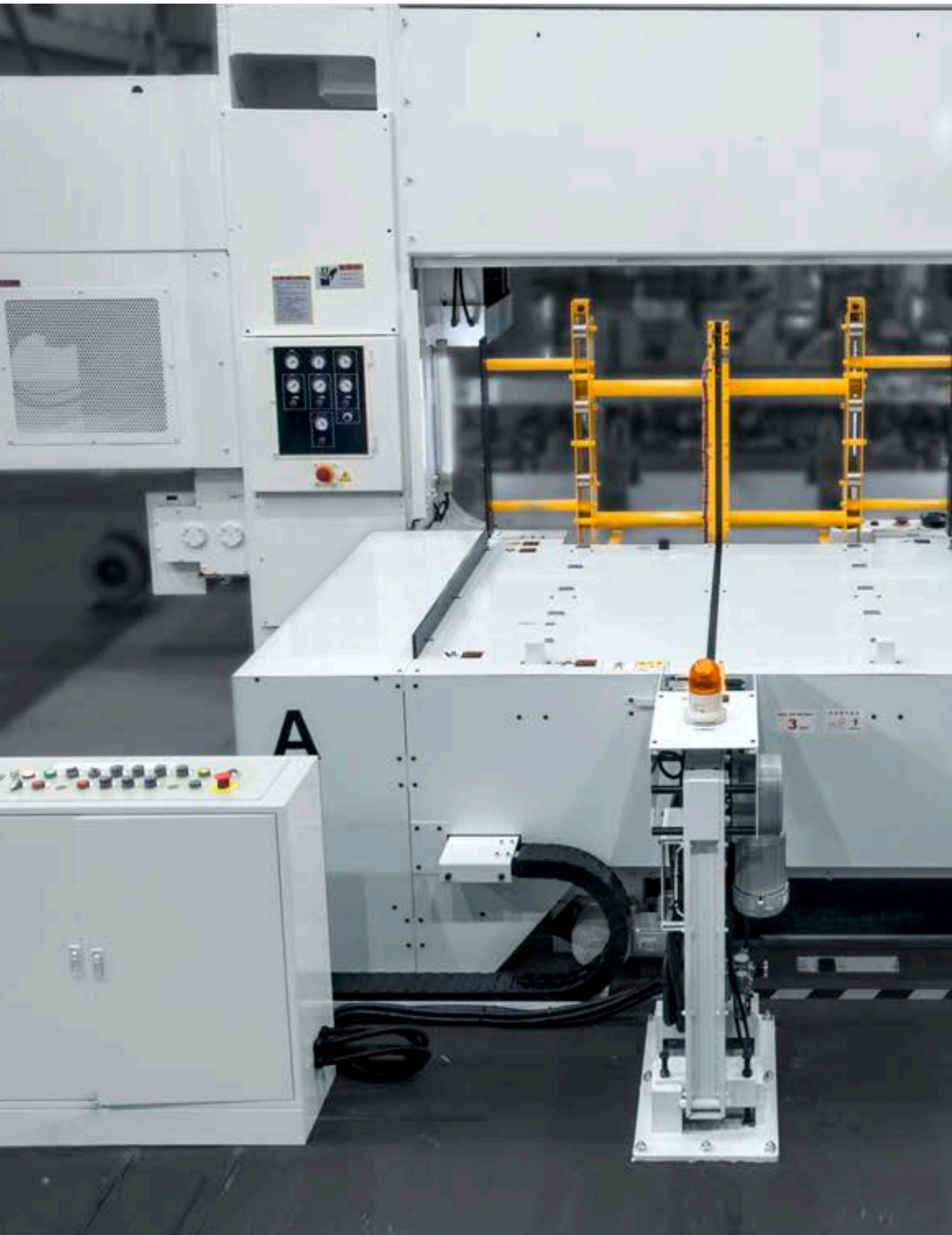

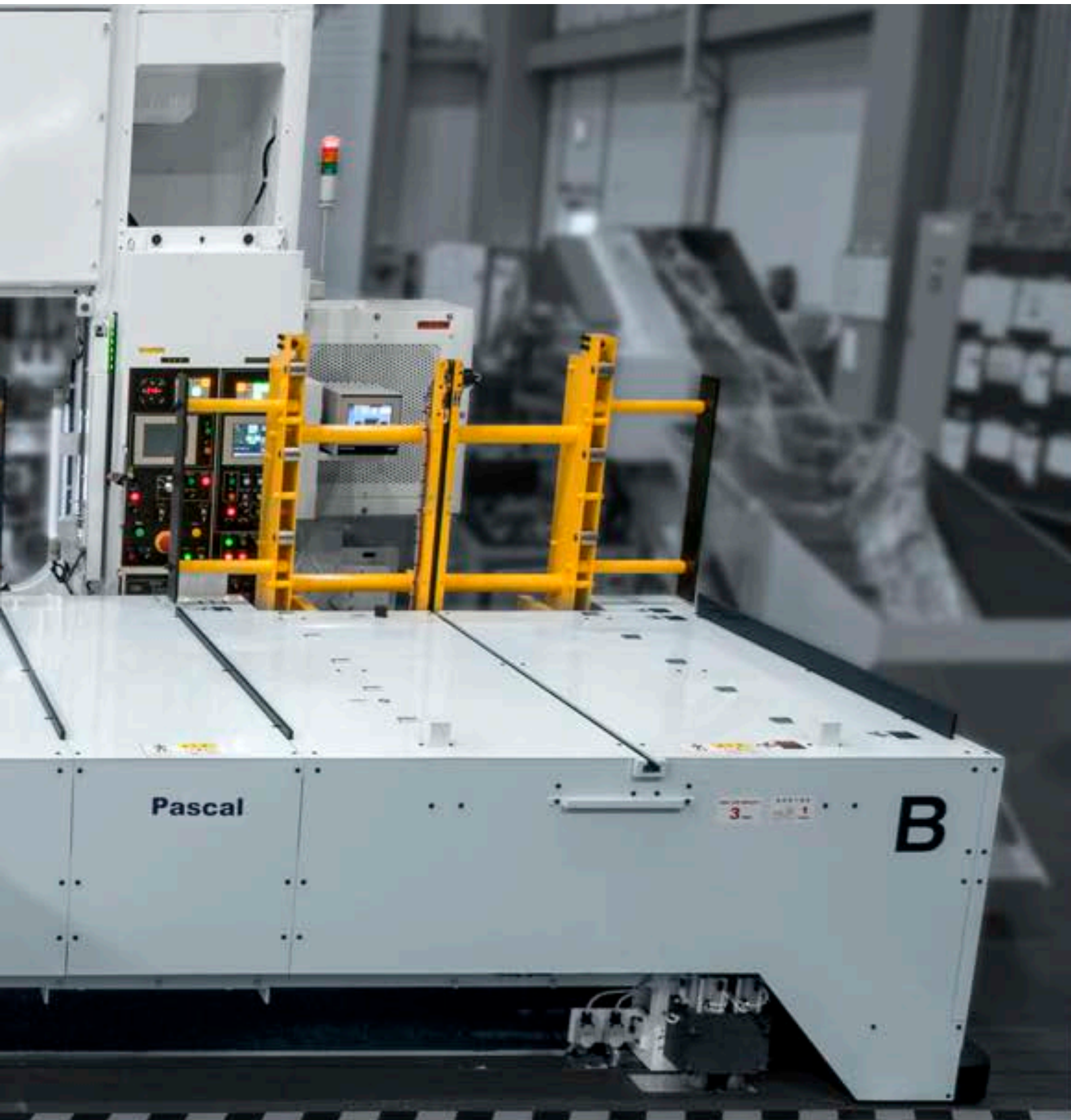

Stamping die changer

8,000kN press

Stamping die station

8,000kN press





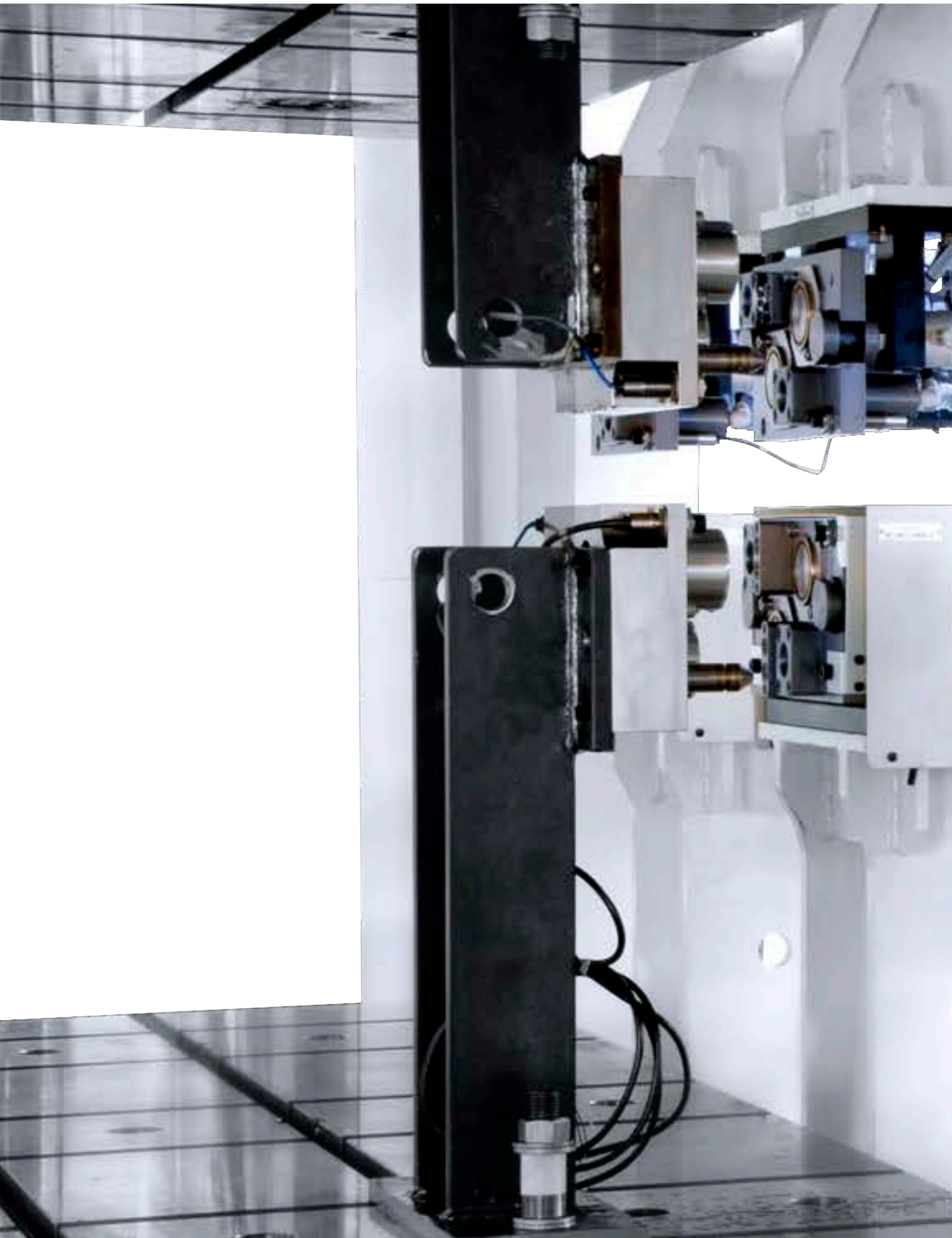

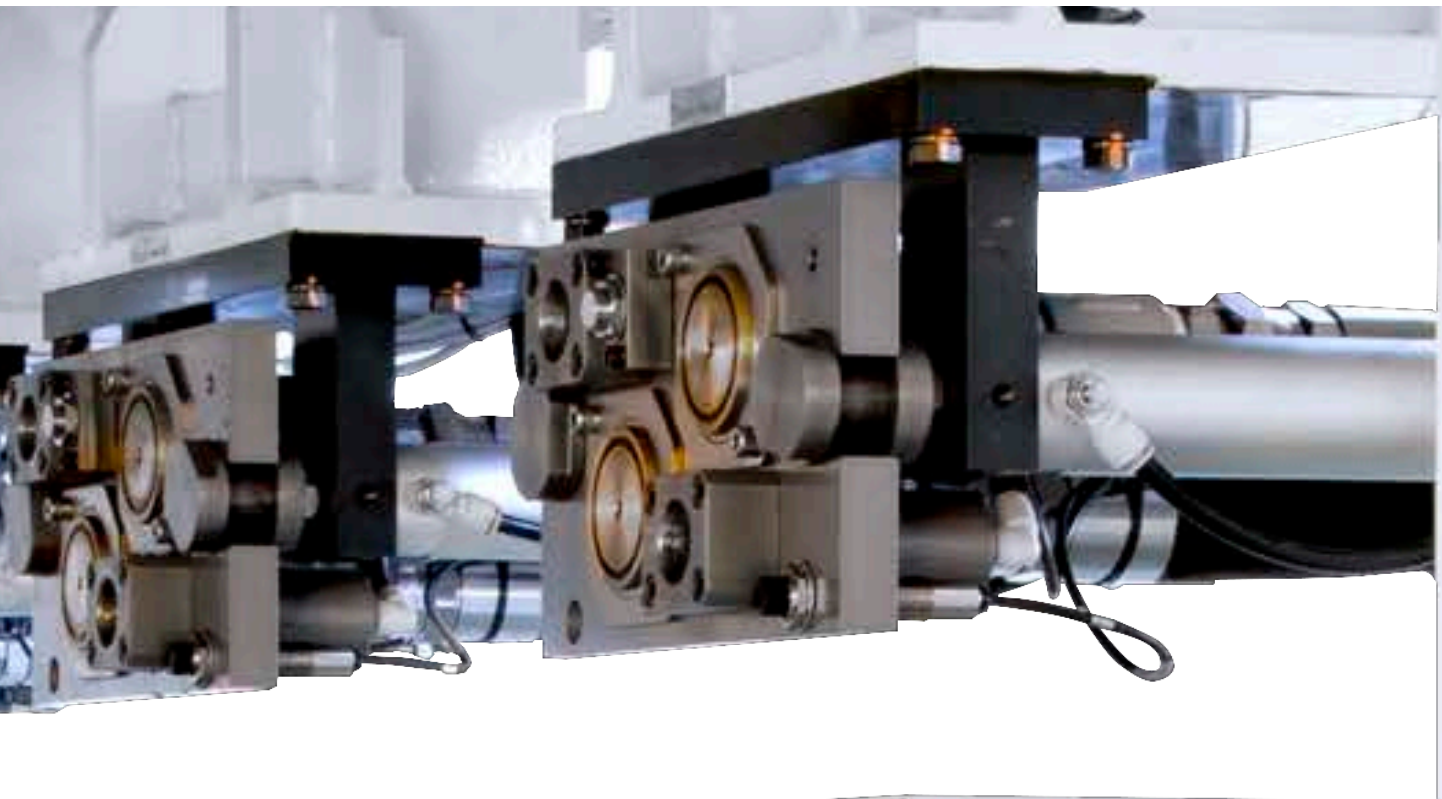

auto coupler

12,000kN hot press

Pascal pump

model **X63**

New series of Pascal pump model X63
which pursues more reliability



Pascal control unit

model **HCS**

New control unit model **HCS**
with excellent maintenance



Pascal clamp

model **TXA**



page → 28

It is slotted in T-slot and U-cut of the die is clamped.

Accessory Clamp hook model **FX** □
For TXA temporary hanging page → 41

model **TYA**



page → 84

T-slotted manual slide type of clamp with lever. It is suitable for the die without U-cut in clamp portion.

Accessory Clamp hook model **FYA**
For TYA temporary hanging page → 99

model **TXC**

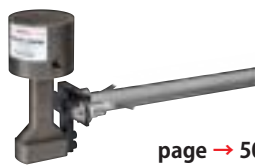

page → 50

Automatic slidable clamp with air cylinder. It enables to shorten the die exchange time.

model **TYC**



page → 102

Automatic slidable clamp with air cylinder. It enables to shorten the die exchange time.

model **TXE**

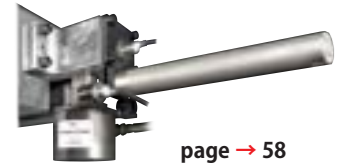

page → 58

Automatic slidable clamp which utilizes the entire lower surface.

model **TRX**



page → 74

Motor driven traveling clamp which overhangs minimum from the edge of the machine slide.

Die-lifter & Die-roller

Die-lifter model **DLF**



With DLF series, heavy dies are lifted by hydraulic force. The rollers enable operator to move the die easily and smoothly. page → 113

Die-roller model **DRA**



A spring lifting roller that does not need hydraulic source. The compact design allows an easy installation just to slot in the die T-slots. page → 135

Pre-roller & Pre-roller stand

Pre-roller

model **PR**



Arm rollers being mountable on the edge of the machine bolster to carry die in or out of the machine easily when die changing. page → 139

Pre-roller stand

model **PRM**



page → 199

It has more excellent rigidity compared with pre-roller and there is very little displacement under the load so that the loading/unloading the die can be smoothly performed.

Control system

Pascal control unit (solenoid operated)

It is an air-driven hydraulic control unit of the electrical control (solenoid operation), combined with Pascal pump and Pascal non leak valve unit.

model **HCS**
(For small and medium press machine)
page → 223



model **HCP**
(For medium and large press machine)
page → 225



Pascal power unit

A hydraulic source combined with a compact and high capacity Pascal pump and oil reservoir for actuation of the clamp. It can discharge 24.5 MPa of hydraulic pressure by means of compressed air.

model **HUT**
page → 229



Air solenoid valve unit

model **GSA**
page → 233
An air directional solenoid valve unit. It is applied for the automatic slidable clamp TXC/TYC with air cylinder control.



Pascal non-leak valve unit

A directional hydraulic valve unit for clamp actuation. It contains a reliable non leak valve in the body to positively maintain the circuit pressure even though power source fails to deliver the oil.

model **VHA**
(Manual operated)
page → 227



model **VS**
(Solenoid operated)
page → 231



Clamp model

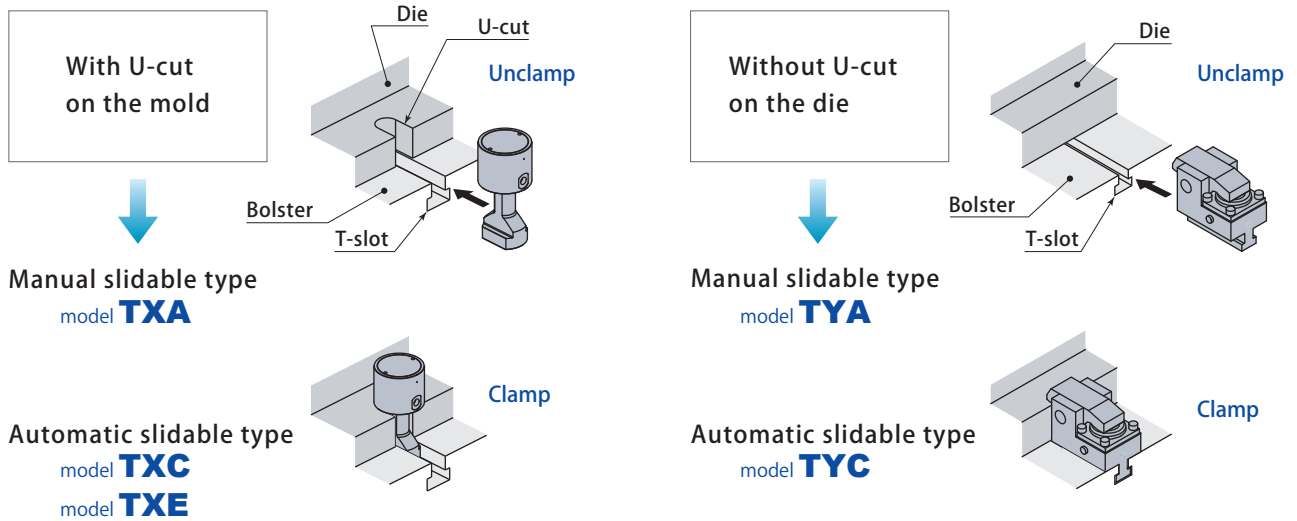

* The unification of die thickness is conditions for the clamp use.
If it is not unified, contact Pascal.

Swing clamp

The clamp rod swings and prevents the interference at time of load/unload of die.

* It is not mentioned in this catalogue, so contact Pascal.

model **TNA** model **THB**

Clamp force and quantity

Determine the size and quantity of the clamp in such a way that the total clamping force, i.e. clamping force by quantity, must be higher than the value stated below.

It should be better for stamping operation to increase the number of the clamp by lowering the force for each clamp, rather than decreasing the number of clamps raising the force for each.

$$\text{The total clamping force, i.e. clamp force by quantity} > \begin{cases} \text{Crank press} & : 10\% \text{ of machine tonnage} \\ \text{High speed press} & : 20\% \text{ of machine tonnage} \\ \text{Hydraulic press} & : \text{die opening force} \end{cases}$$

For tonnage 1100kN crank press

If 4 pieces of model TXA040 (clamping force 39.2kN) are installed on both of slide and bolster, total clamping force would be 156.8kN (39.2 x 4), which represents about 14% of machine tonnage.

The proper size and quantity of clamps differs depending on the condition of die and machine. Please contact Pascal sales representative or customer center for the details.

Selection of stamping die clamping system

Pascal control system

For the control system supplying the hydraulic pressure to the Clamp and Die-lifter, the compacted Control unit model HCS is recommended. For the manual operation, please select the Non leak valve unit model VHA(operated manually) and Power unit model HUT.

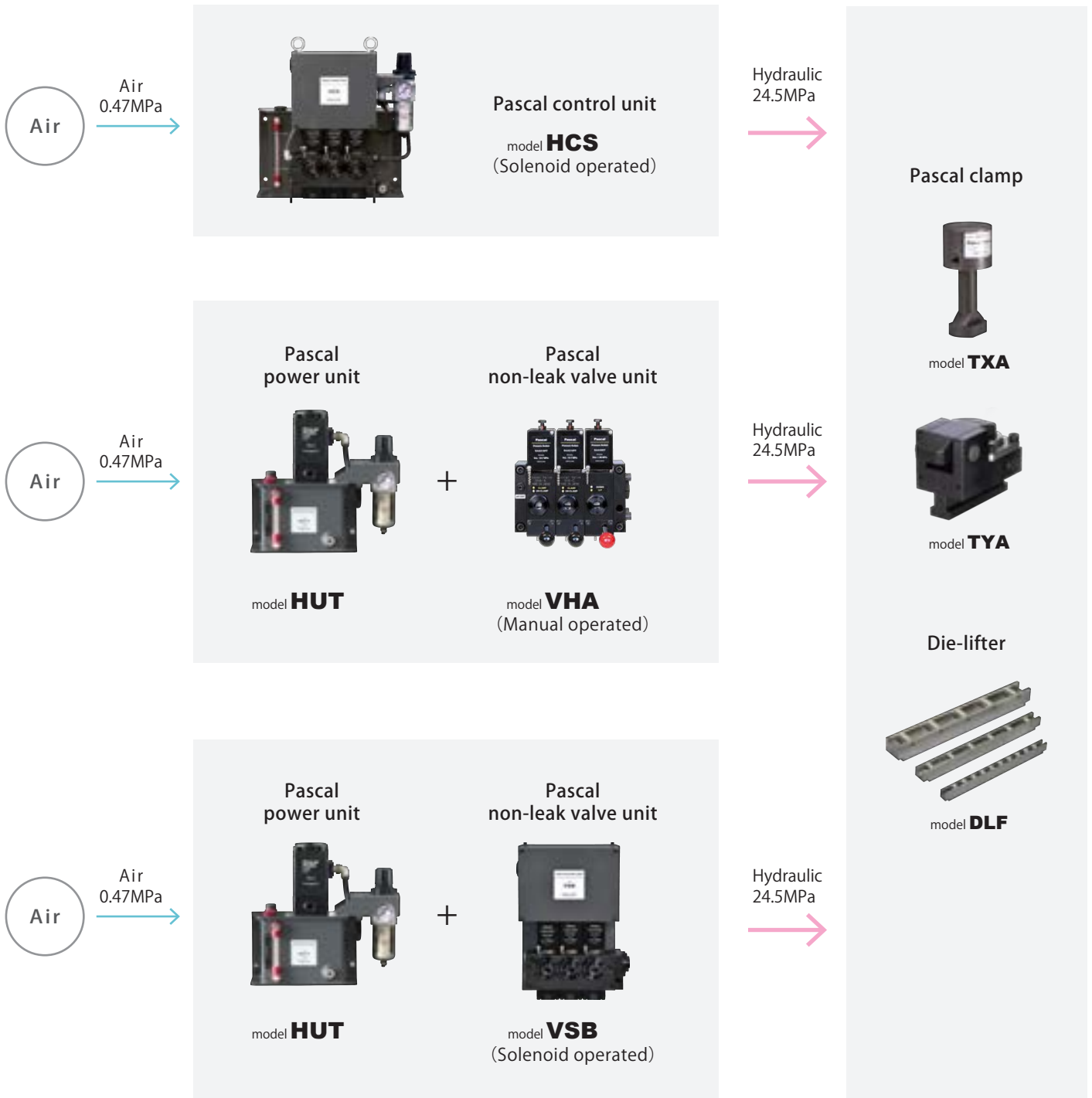

Example of hydraulic circuit

D D F circuits (Solenoid operated)

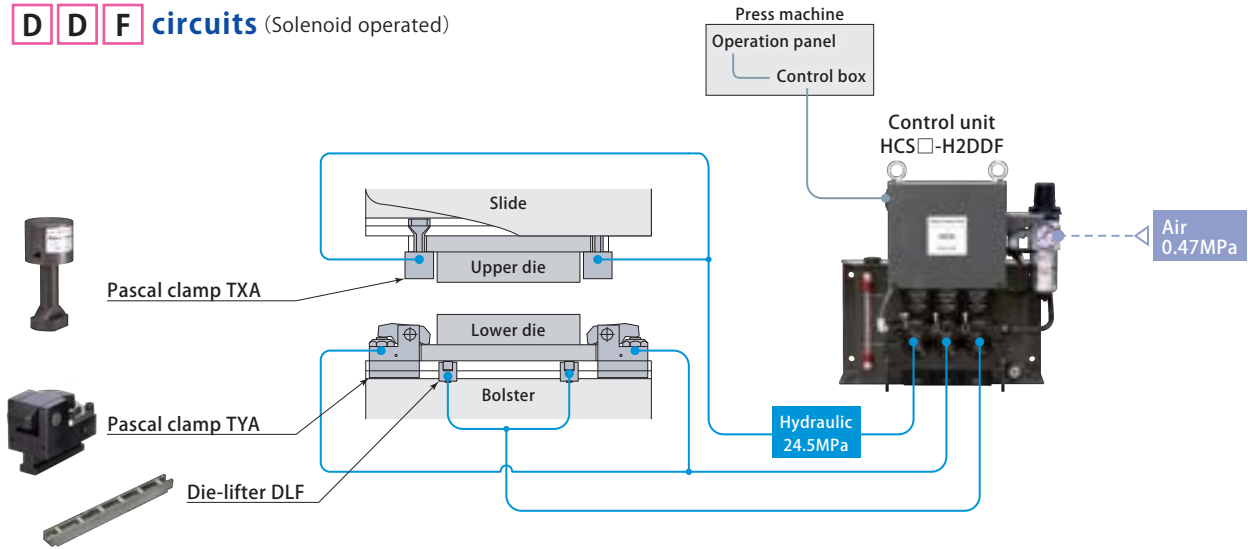

A C circuits (Manual operated)

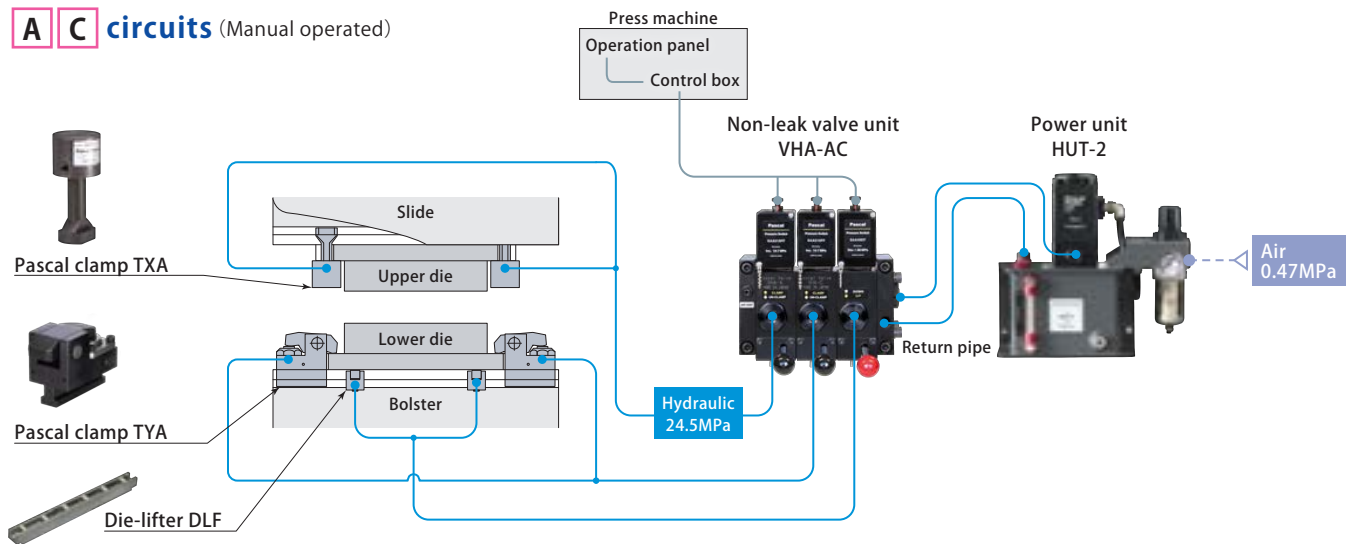

D D F circuits (Solenoid operated)

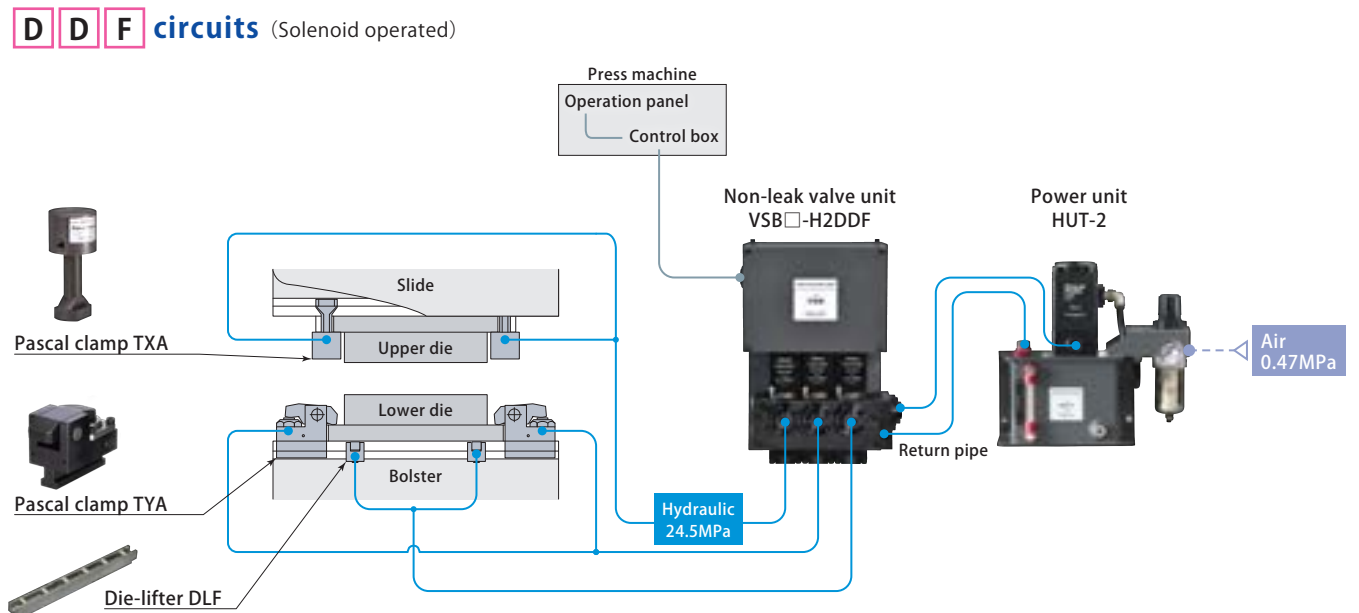

Pascal clamp model TXA

Pascal clamp





Model designation

TXA **063**

Clamping force
Refer to the below specifications for the details.



Clamp hook
model FXseries
(Accessory)

For temporary hanging.
Refer to **page → 41**
for the details.

Specifications

Model		TXA010	TXA020	TXA040	TXA063	TXA100	TXA160	TXA250
Clamping force (at 24.5 MPa)	kN	9.8	19.6	39.2	61.7	98	156	245
Proof pressure	MPa	36.7						
Full stroke	mm	5				8		
Clamping stroke	mm	3				5		
Safety stroke	mm	2				3		
Cylinder capacity (at full stroke)	cm ³	2.0	6.5	13	21	32	54	84
Operating temperature	°C	0 ~ 70 (Standard)						
Approximate weight	kg	0.7	1	2	3	5	8	18

- Working hydraulic pressure : 24.5MPa
- Weight varies according to the die thickness and dimension of clamp rod.
- Clamping stroke and safety stroke are the standard, however they are subject to change depending on dimensions of die and T-slot. Contact Pascal for the details.

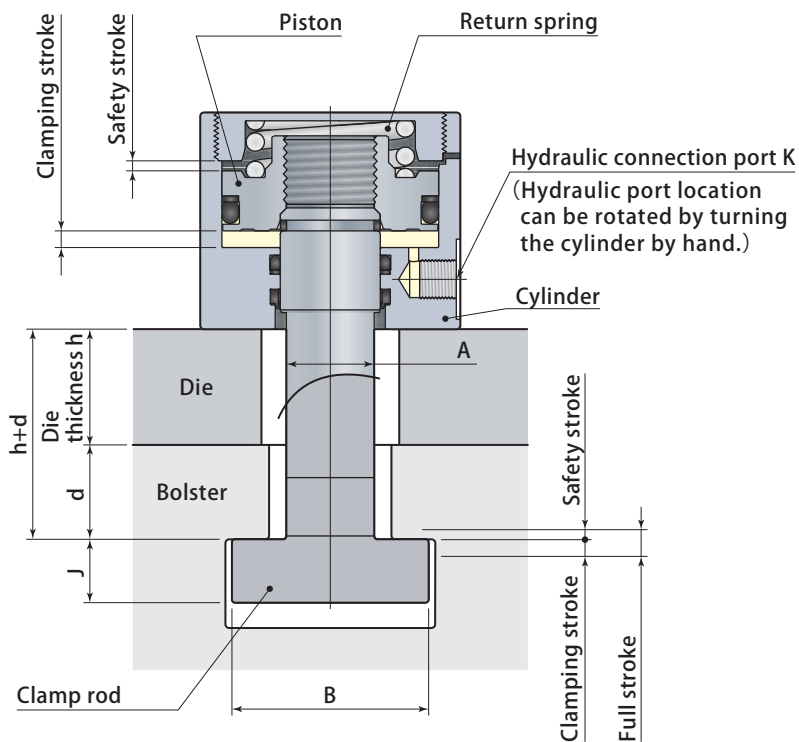
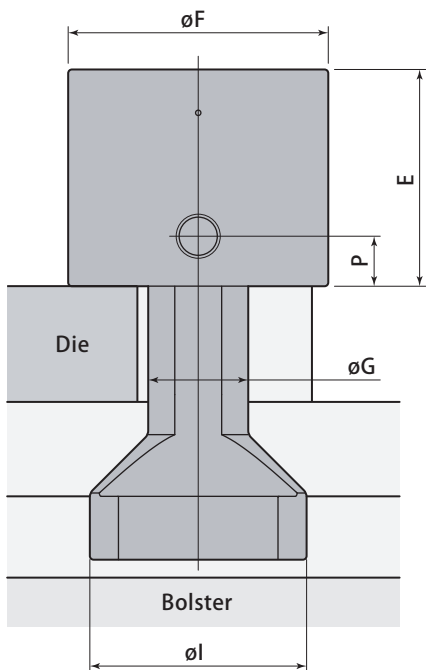

T-slot dimension and die thickness

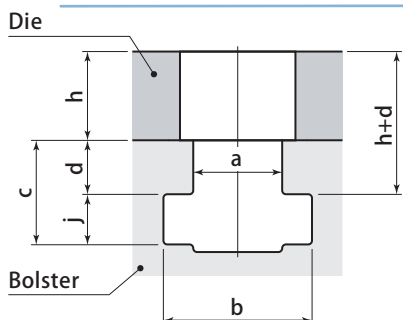

U-cut dimension

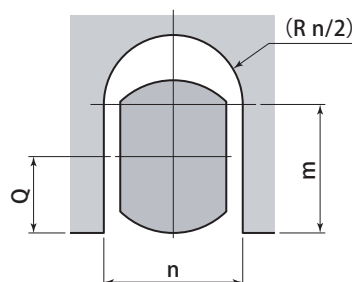

mm

Model	TXA010	TXA020	TXA040	TXA063	TXA100	TXA160	TXA250
E	37	52	59	65	71	78	100
øF	38	49	62	78	98	127	157
øG	13	16	25	30	40	50	60
øI	30	38	60	65	80	90	100
Hydraulic connection port K	Rc1/8	Rc1/4					
P	9	12	13.5	15	16	16	18
Min. a	6	10	12	15	18	23	27
Max. h+d	70	80	90	100	110	120	120
Tolerance of dimension d	± 0.2						
Min. j	6	9	11	15	18	21	24
Tolerance of dimension h	± 0.3						
m	13.5	17	23.5	29	38	47	56
Min.Q	7	9	11	14	18	22	26
Max.n	20	30	35	40	50	60	70

- Specify T-slot dimensions a, b, d, j and die thickness h. For brand new machine, machine d and h dimensions with the tolerance shown in the above table. For existing machine, specify tolerance of 0.1mm unit on d and h dimensions.
- Dimensions A, B, J are determined based on T-slot dimension.
- In case U-cut width n is smaller than T-slot dimension a, contact Pascal.
- In case dimension is over Max. h+d, refer to the **page →32** Long clamp rod type.

H Long clamp rod type TXA□-H

It is applied in case the die thickness is over the standard.
page → 32

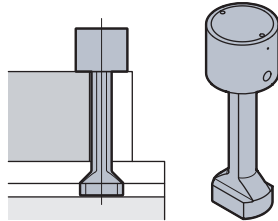

E With die detection proximity switch TXA□E

It prevents clamp misplace.
page → 33

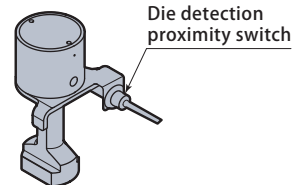

V Heat proof type TXA□-V

It is applied under condition that the die and its surroundings are in high temperature.

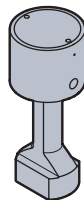

Operating temperature : 5 ~ 120°C

X Long stroke type TXA□-X

It is applied in case the variations of dimension h of die thickness are wide.
page → 34



K Cylinder fixed type TXA□K

It is applied in case the cylinder is mounted in bolster.
page → 35

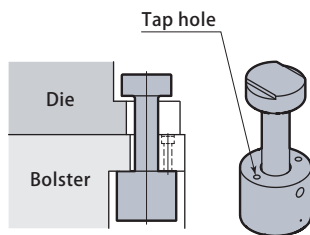

W Wide rod type TXA□W

It is applied at the point which intersects with T-slot or the point with cushion pin hole.
page → 37

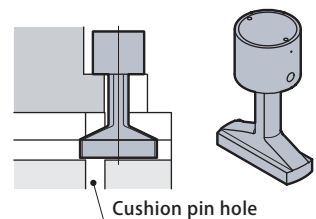

L Lock type TXA□-L

It can fix the clamp installed on the position out of reach, such as the rear side.
page → 38

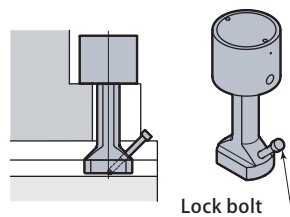

S Clamp rod thread type TXA□-S

It is applied without T-slot.
page → 39

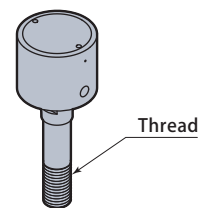

H Long clamp rod type It is applied in case the die thickness is over the standard.

Model designation

TXA 063 - H

- Clamping force
 TXA010 TXA020 TXA040 TXA063
 TXA100 TXA160 TXA250

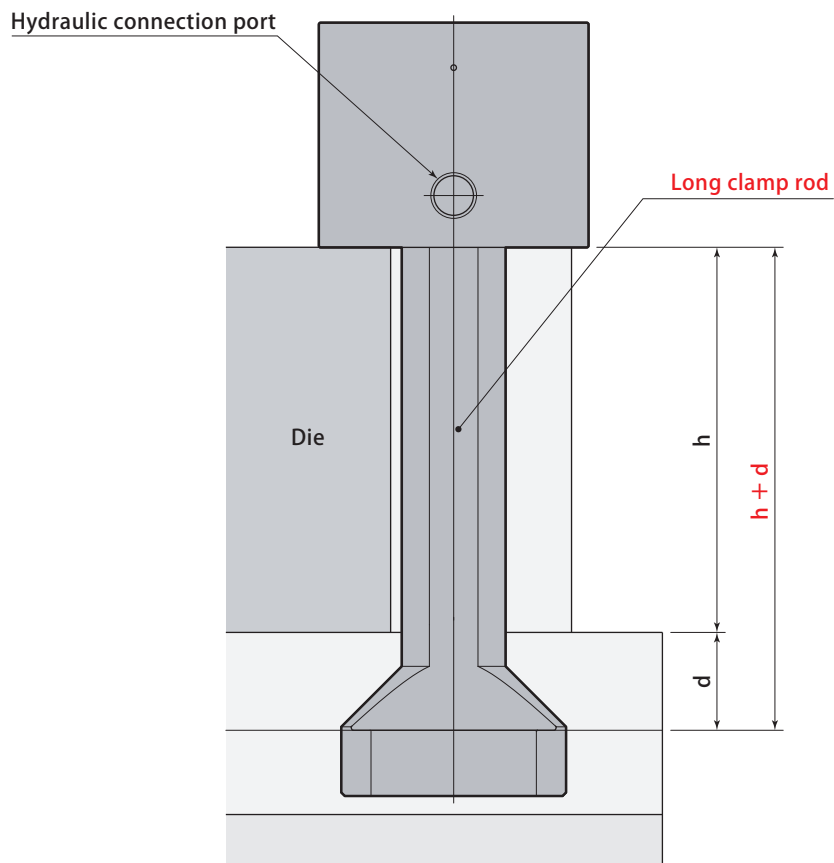

Model	TXA010-H	TXA020-H	TXA040-H	TXA063-H	TXA100-H	TXA160-H	TXA250-H
$h + d$	$h+d > 70$	$h+d > 80$	$h+d > 90$	$h+d > 100$	$h+d > 110$	$h+d > 120$	$h+d > 120$

mm

E With die detection proximity switch

It prevents clamp misplace.

Model designation

TXA **063** **E** **0** **L**

- 1 Clamping force •
 - 2 Proximity switch •
 - 3 Mounting position of die detection proximity switch
- 1 Clamping force
TXA040 TXA063 TXA100
 - 3 Mounting position of die detection proximity switch
L : Left side **R** : Right side

2 Proximity switch

Symbol of proximity switch model	0	1	2	3
Specifications	DC24V 2-Wire	DC24V 3-Wire(NPN)	AC100V 2-Wire	DC24V 3-Wire(PNP)
Model	E2E-X7D1-N	E2E-X5E1	E2E-X5Y1	E2E-X5F1
Manufacturer name	OMRON			
Insulation vinyl cable length	5m			

Mounting position of die detection proximity switch

L : Left side

Die detection proximity switch

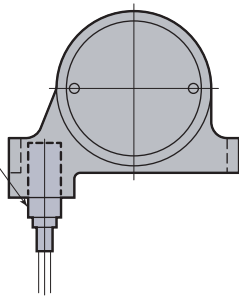

Mounting position of die detection proximity switch

R : Right side

Die detection proximity switch

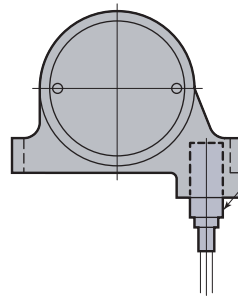

Hydraulic connection port
(Port position is unchangeable.)

Hydraulic connection port
(Port position is unchangeable.)

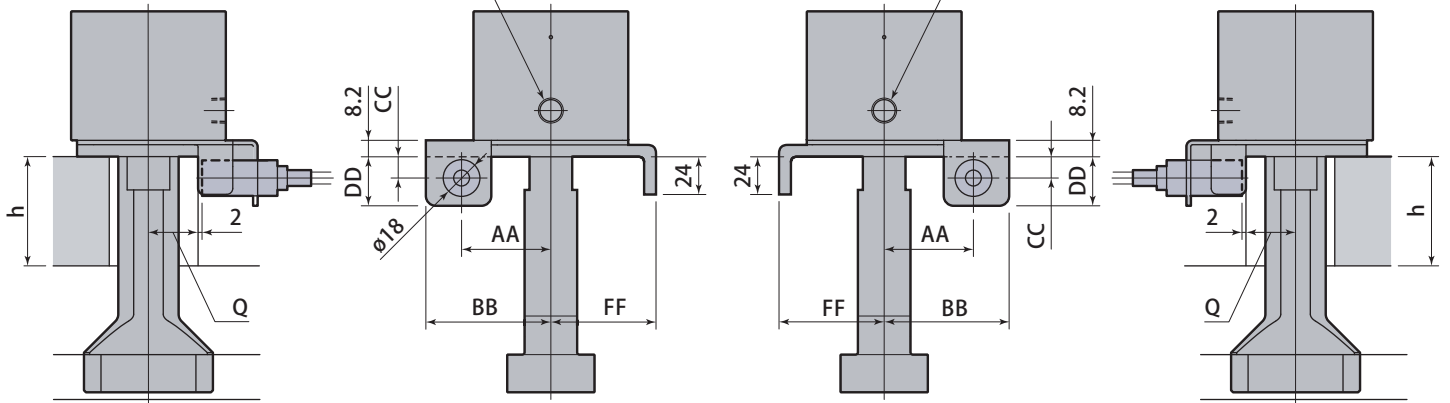

Model	TXA040E	TXA063E	TXA100E
AA	45	45	51.5
BB	63	63	75
FF	53	53	60
DD	24.7	24.7	31.7
CC	10.7	10.7	16.7
Q	22	25	30
Min. h	30	30	40

mm

X Long stroke type It is applied in case the variations of dimension h of die thickness are wide.

Model designation

TXA 063 - X 10

- 1 Clamping force
- 2 Full stroke (mm)

- 1 Clamping force
TXA020 TXA040
TXA063 TXA100 TXA160

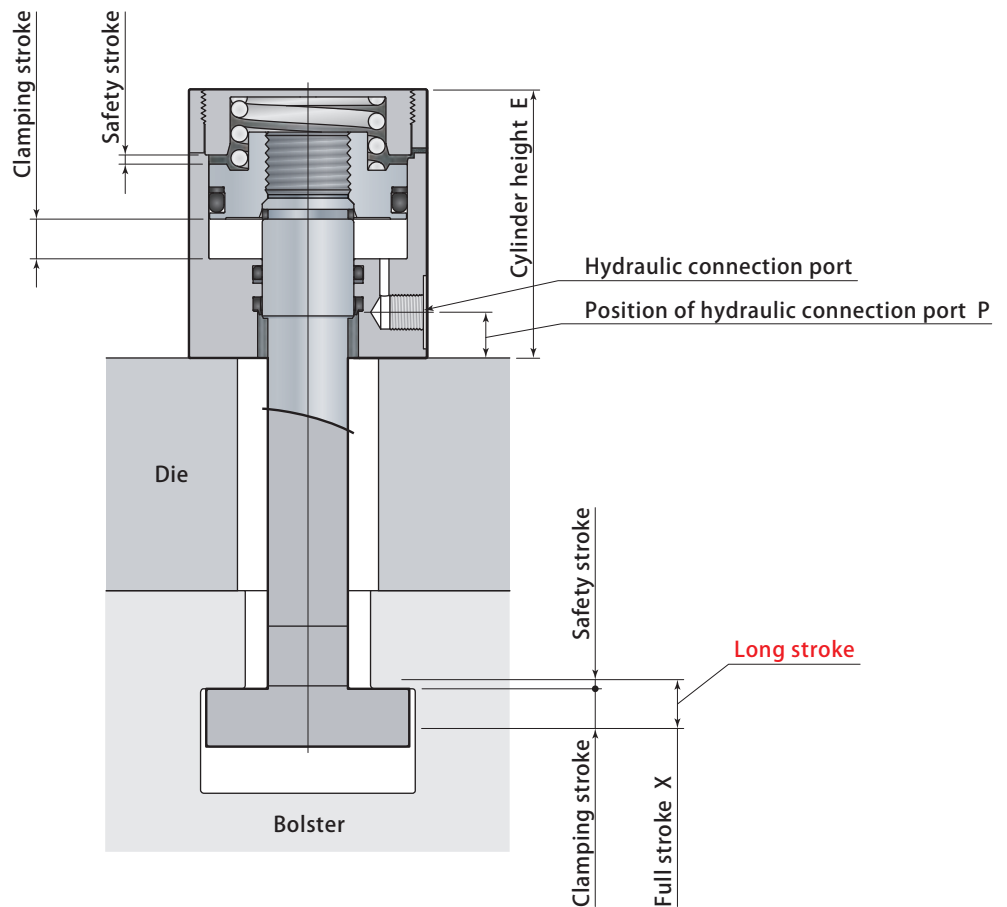

2 Full stroke (mm) 10 ~ 20 mm

● TXA020-X mm

Full stroke X	—	12	16	20
Cylinder height E	—	65	73	81
Position of hydraulic connection port P	—	12	12	20

● TXA063-X mm

Full stroke X	10	12	16	20
Cylinder height E	73	77	88	103
Position of hydraulic connection port P	15	17	15	27

● TXA040-X mm

Full stroke X	10	12	16	20
Cylinder height E	63	67	80	94
Position of hydraulic connection port P	15.5	15.5	13.5	13.5

● TXA100-X mm

Full stroke X	10	12	16	20
Cylinder height E	79	83	94	107
Position of hydraulic connection port P	16	16	16	16

- Pascal selects optional length of the stroke. Contact Pascal for the details.
- Confirm the length of clamping stroke and safety stroke with the approval drawing.

● TXA160-X mm

Full stroke X	10	12	16	20
Cylinder height E	80	86	101	109
Position of hydraulic connection port P	16	20	24	28

K Cylinder fixed type It is applied in case the cylinder is mounted in bolster.

Model designation

TXA 063 K - 080

1 Clamping force ●.....

2 Clamping height (mm) ●.....

* Indicated in 3 digits

1 Clamping force
TXA020 TXA040 TXA063 TXA100

2 Clamping height L (mm)
Refer to the below table "Range of clamping height L/ tolerance".

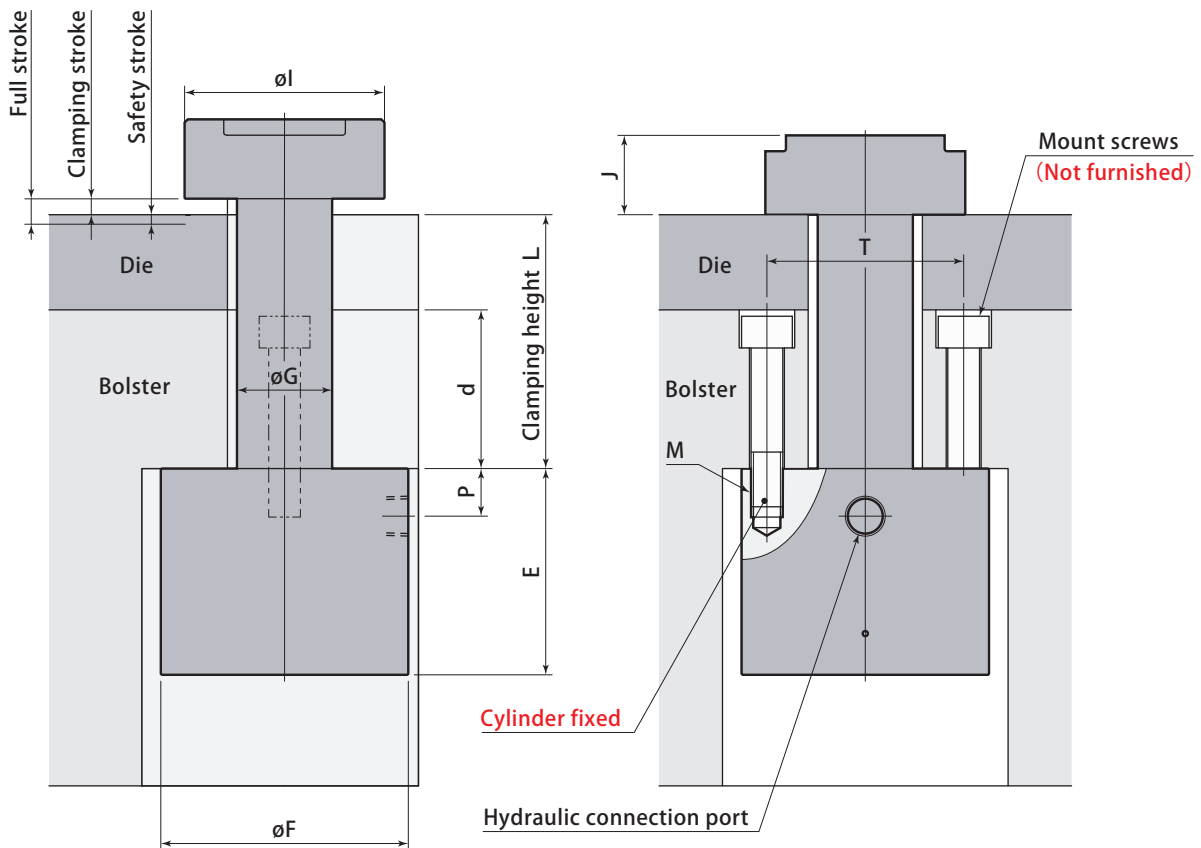

mm

Model	TXA020K	TXA040K	TXA063K	TXA100K
ø l	40	50	63	75
J	18	25	25	32
ø G	16	24	30	34
P	12	13.5	15	16
E	52	59	65	71
ø F	49	62	78	98
T	36	46	62	82
M	M6 depth 10	M6 depth 12	M10 depth 15	M10 depth 15
2 Range of clamping height L	50 ~ 100	65 ~ 220	80 ~ 220	85 ~ 230
2 Tolerance of clamping height L dimension	± 0.5	± 0.5	± 0.5	± 0.5

- Specify clamping height L dimension.
- In case the lift stroke of Die-lifter is large, the clamping stroke extension is necessary, so contact Pascal.

Mounting details

U-cut dimension

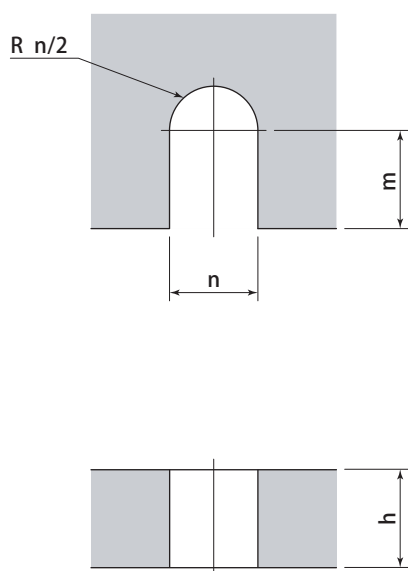

Dimensional drawing to clamp on bolster

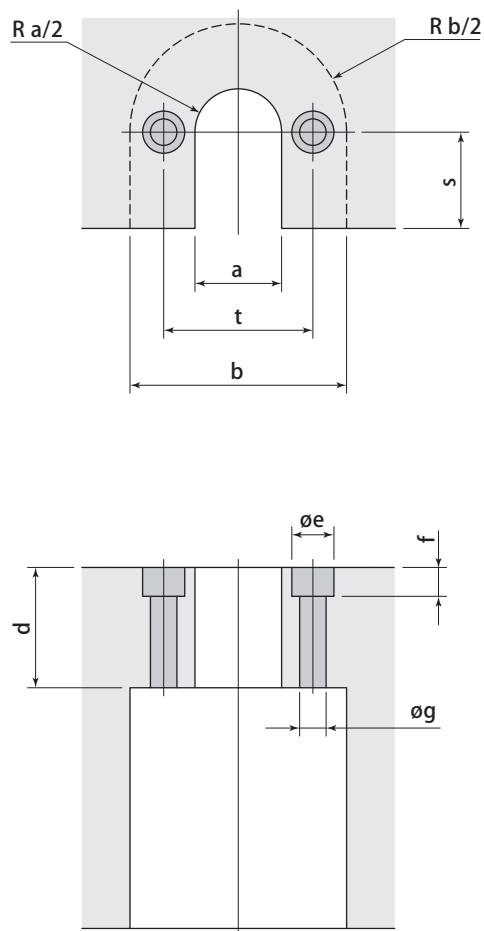

Model	TXA020K	TXA040K	TXA063K	TXA100K
a	20	28	36	38 ~ 42
t	36	46	62	82
b	52	70	90	110
Min. d	30	40	50	50
Min. h	20	25	30	30
ø e	11	11	17.5	17.5
f	8	8	13	13
ø g	6.8	6.8	11	11
n	20	28 ~ 30	34 ~ 36	38 ~ 42
Min. m	20	20	40	35
Min. s	25	32	40	50

mm

W Wide rod type It is applied at the point which intersects with T-slot or the point with cushion pin hole.

Model designation

TXA 063 W

Clamping force TXA010 TXA020 TXA040
TXA063 TXA100 TXA160

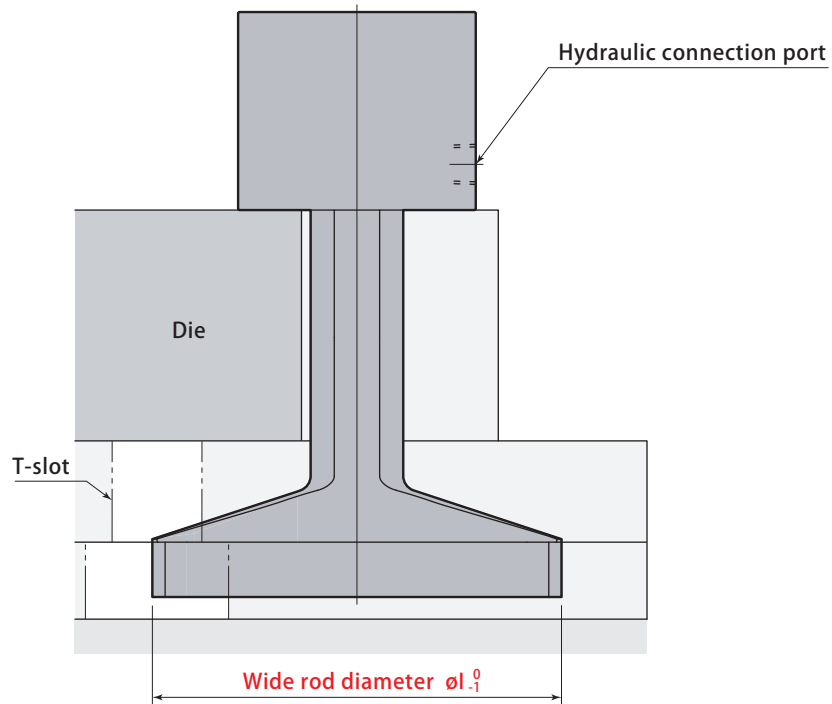

Model	TXA010W	TXA020W	TXA040W	TXA063W	TXA100W	TXA160W
Wide rod diameter øl	45	58	90	98	120	135

- In case the clamp is placed at the T-slot that has a hole for the cushion pin, specify the dimension of the clamp rod referring to the table shown below.

Model designation

TXA 063 W - 095

Clamping force TXA040
TXA063
TXA100

Wide rod diameter øl (mm)
*When choose special type,
the 3 digits number is
added in the end.

Max. producible rod diameter øl

Model	TXA040W-□	TXA063W-□	TXA100W-□
Clamp rod diameter øG	25	30	40
Cushion pin hole diameter øp	30	95	110
	35	105	120
	40	115	130
	45	125	140
	50	135	150
	55	145	160
	60	155	170
	65	165	180
70	175	190	

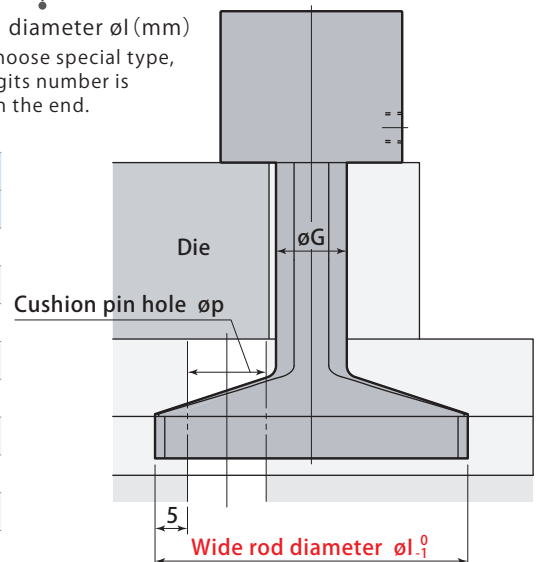

Relational expression $øl = (øp + øG \div 2 + 5) \times 2$

L Lock type It can fix the clamp installed on the position out of reach, such as the rear side.

Model designation

TXA **063** - **L**

Clamping force TXA020 TXA040 TXA063
TXA100 TXA160

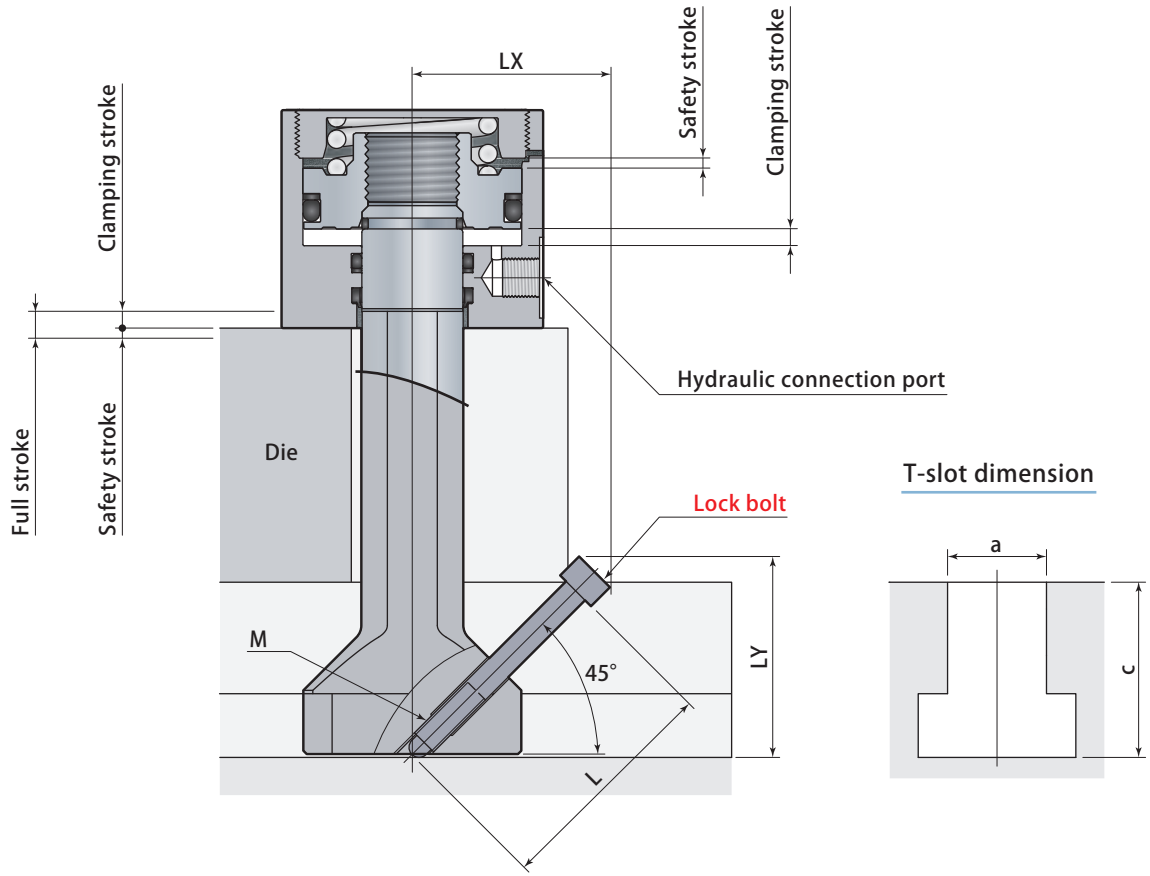

mm

Model	TXA020-L	TXA040-L	TXA063-L	TXA100-L	TXA160-L
Min. a	11.5	14.5	15	18	23

● Lock bolt size differs according to c dimension of T-slot.

mm

Model	TXA020-L			TXA040-L	TXA063-L	TXA100-L	TXA160-L
Range of c dimension of T-slot	M×L	LX	LY	M×L	LX	LY	
17.7 < c ≤ 21.2	M6×29	27.9	28.9	M8×29	30.6	31.6	
21.2 < c ≤ 24.7	M6×34	31.4	32.4	M8×34	34.2	35.2	
24.7 < c ≤ 28.2	M6×39	34.9	35.9	M8×39	37.7	38.7	
28.2 < c ≤ 31.8	M6×44	38.5	39.5	M8×44	41.2	42.2	
31.8 < c ≤ 35.3	M6×49	42.0	43.0	M8×49	44.8	45.8	
35.3 < c ≤ 38.8	M6×54	45.5	46.5	M8×54	48.3	49.3	
38.8 < c ≤ 42.3	M6×59	49.1	50.1	M8×59	51.9	52.9	
42.3 < c ≤ 45.9	M6×64	52.6	53.6	M8×64	55.4	56.4	
45.9 < c ≤ 49.4	M6×69	56.2	57.2	M8×69	58.9	59.9	
49.4 < c ≤ 52.9	M6×74	59.7	60.7	M8×74	62.5	63.5	
52.9 < c ≤ 56.5	M6×79	63.2	64.2	M8×79	66.0	67.0	
56.5 < c ≤ 60.1	M6×84	66.8	67.8	M8×84	69.5	70.5	

S Clamp rod thread type It is applied without T-slot.

Model designation

TXA 063 - S

- Clamping force
TXA010 TXA020 TXA040
TXA063 TXA100 TXA160

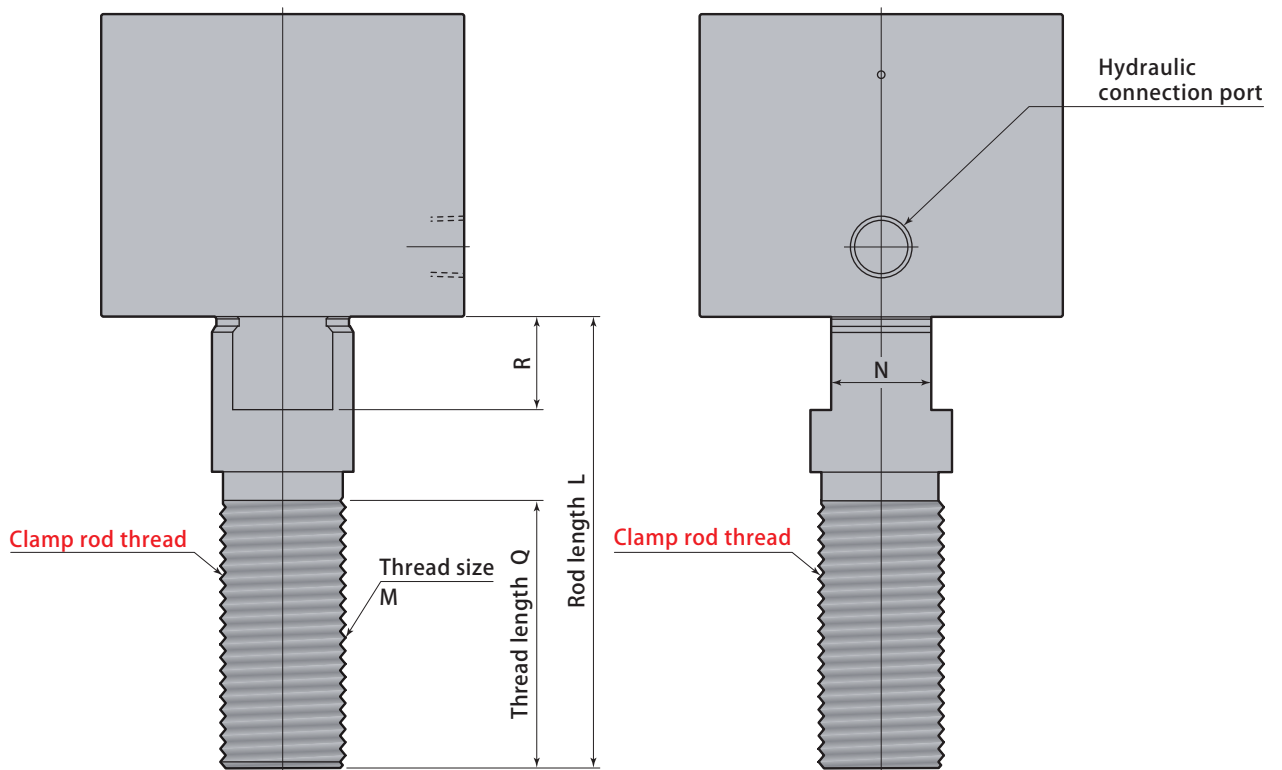

● The drawing indicated : position of unclamped

Model		TXA010-S	TXA020-S	TXA040-S	TXA063-S	TXA100-S	TXA160-S
Thread size	M	M12 × 1.75	M16 × 2	M22 × 2.5	M27 × 3	M36 × 4	M45 × 4.5
Width across flats	N	10	11.5	18.5	21.5	29.5	35.5

● Specify the thread length Q and rod length L.

● R dimension to be changeable depending on Q and L dimensions.

Model	TXA010-S	TXA020-S	TXA040-S	TXA063-S	TXA100-S	TXA160-S
Width across flats height R Inside the brackets range of L-Q	10 (10 < L-Q ≤ 20)					-
	20 (20 < L-Q)					-
	-					15 (15 < L-Q ≤ 25)
	-					25 (25 < L-Q)

For TXA temporary hanging

FX A Upper clamp hook page → 42

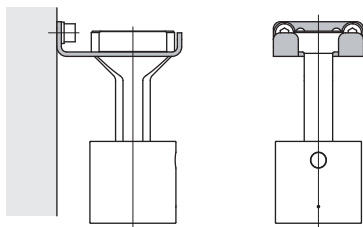

* Not applicable for model TXA □ W.

FX A Lower clamp hook page → 42

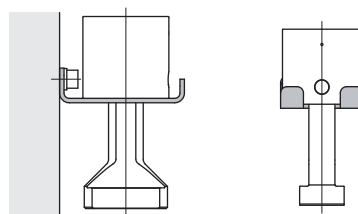

* Not applicable for model TXA □ E.

FX B Upper clamp hook with LS page → 43

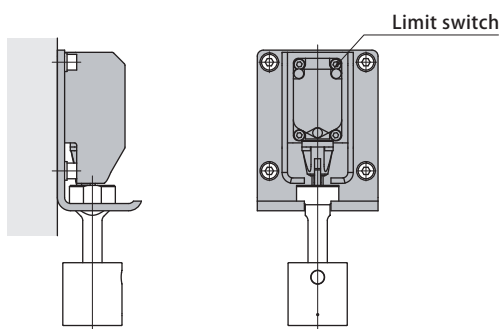

* Not applicable for model TXA □ W.

FX C Lower clamp hook with LS page → 44

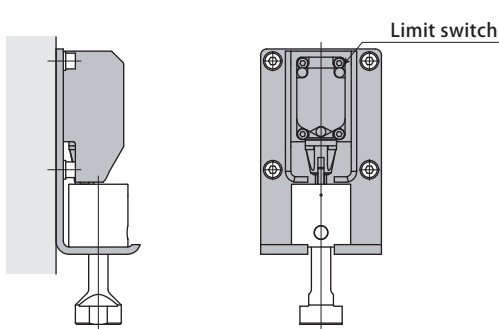

* Not applicable for model TXA □ E, TXA-X □ and TXA □ W.

FX D Upper clamp hook with dummy plate page → 45

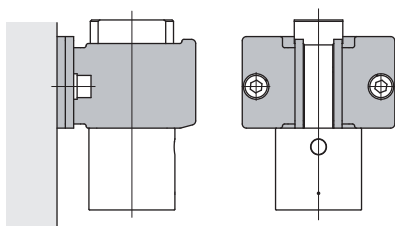

* Not applicable for model TXA □ W.

FX D Lower clamp hook with dummy plate page → 45

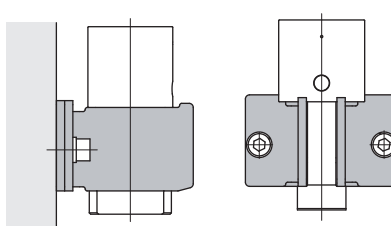

* Not applicable for model TXA □ W.

FX E Upper clamp hook with LS and dummy plate page → 46

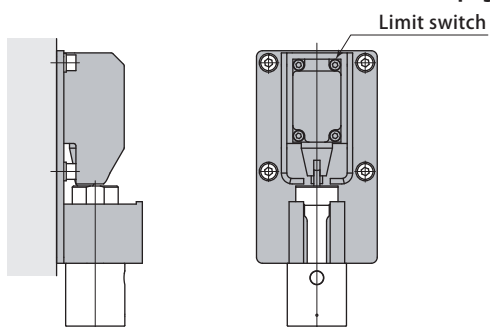

* Not applicable for model TXA □ W.

FX F Lower clamp hook with LS and dummy plate page → 47

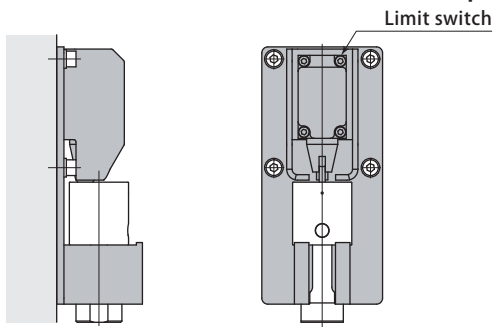

* Not applicable for model TXA □ E, TXA-X □ and TXA □ W.

* Contact Pascal for the details.

Model designation

FX A 01 - 18

- 1 Hook size
- 2 W dimension (mm)

- 1 Hook size
FXA01 FXA02 FXA03
- 2 W dimension (mm)
Refer to the below table

Installation example of the upper type of clamp

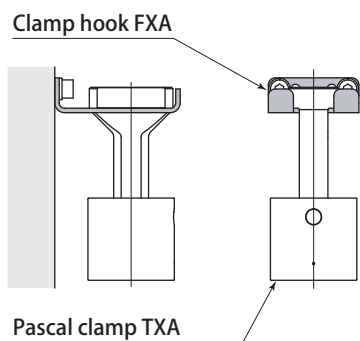

Installation example of the lower type of clamp

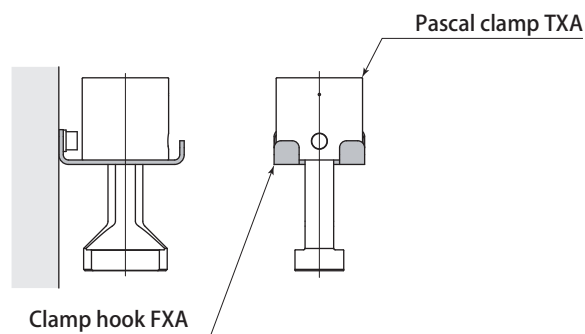

- The shape of the upper and lower type of hook is the same.
- Do not operate the machine with clamp hung on the clamp hook.

T-slot dimension

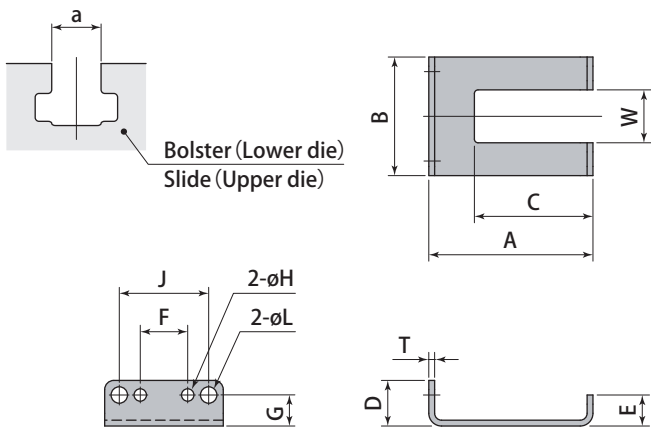

- The mount screw is not furnished. If necessary, order the mount screw type sold separately.

øH Mount screw

Hook type	Reference specification	Mount screw type (option)
FXA01	2-M5 length 12	FXA-A05
FXA02	2-M6 length 14	FXA-A06

øL Mount screw

Hook type	Reference specification	Mount screw type (option)
FXA01	2-M6 length 14	FXA-A06
FXA02	2-M8 length 16	FXA-A08
FXA03	2-M8 length 16	FXA-A08

Clamp model	TXA010				TXA020 / TXA040					TXA063 / TXA100				TXA160							
	T-slot a	mm	Less than 14	15~18	19~22	23~28	Less than 14	15~18	19~22	23~28	29~34	Less than 22	23~28	29~34	35~40	Less than 28	29~34	35~40	41~46		
Clamp hook type		FXA 01-14	FXA 01-18	FXA 01-22	FXA 01-28	FXA 02-14	FXA 02-18	FXA 02-22	FXA 02-28	FXA 02-34	FXA 03-22	FXA 03-28	FXA 03-34	FXA 03-40	FXA 04-28	FXA 04-34	FXA 04-40	FXA 04-46			
W	mm	14	18	22	28	14	18	22	28	34	22	28	34	40	28	34	40	46			
A	mm		65					90					120					155			
B	mm		50					65					75					100			
C	mm		50					65					90					110			
D	mm		25					25					25					60			
E	mm		12					17					17					24			
G	mm		17					17					17					45			
T	mm		2.3					3.2					3.2					4.5			
F	mm		17					26					—					—			
øH	mm		5.5					6.8					—					—			
J	mm		35					49					49					80			
øL	mm		6.8					9					9					11			
Weight	kg		0.1					0.2					0.3					0.7			

Model designation

FX **B** **01** - **18** - **11**

- 1 Hook size
- 2 W dimension (mm)
- 3 J dimension (mm)

- 1 Hook size
FXB01 FXB02 FXB03
FXB04 FXB05
- 2 W dimension (mm)
Refer to the below table
- 3 J dimension (mm)

Installation example

Do not operate the machine with clamp hung on the clamp hook.

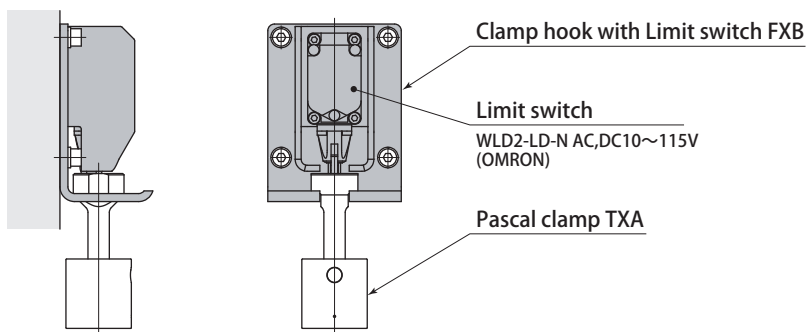

T-slot dimension

T-leg dimension

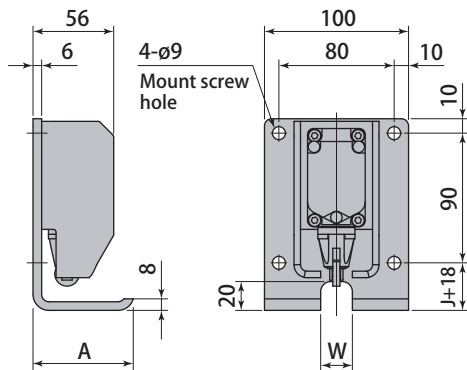
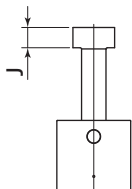
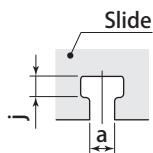

The mount screw is not furnished. If necessary, order the mount screw type sold separately.

Mount screw

Hook type	Reference specification	Mount screw type (option)
FXB01	4-M8 length 16	FXB-A08
FXB02		
FXB03		
FXB04		
FXB05		

Clamp model	TXA010					TXA020				
T-slot a mm	Less than 14	15~18	19~22	23~28		Less than 14	15~18	19~22	23~28	29~34
Clamp hook type	FXB01-14	FXB01-18	FXB01-22	FXB01-28		FXB02-14	FXB02-18	FXB02-22	FXB02-28	FXB02-34
W mm	14	18	22	28		14	18	22	28	34
A mm	55					70				
Weight (Approx) kg (Reference J dimension) mm	1.6 (J=11)					1.6 (J=15)				

Clamp model	TXA040					TXA063				TXA100			
T-slot a mm	Less than 14	15~18	19~22	23~28	29~34	Less than 22	23~28	29~34	35~40	Less than 22	23~28	29~34	35~40
Clamp hook type	FXB03-14	FXB03-18	FXB03-22	FXB03-28	FXB03-34	FXB04-22	FXB04-28	FXB04-34	FXB04-40	FXB05-22	FXB05-28	FXB05-34	FXB05-40
W mm	14	18	22	28	34	22	28	34	40	22	28	34	40
A mm	90					95				110			
Weight (Approx) kg (Reference J dimension) mm	1.7 (J=17)					1.7 (J=19)				1.8 (J=19)			

Model designation

FX C 01 - 18

- 1 Hook size
- 2 W dimension (mm)

- 1 Hook size
FXC01 FXC02 FXC03
FXC04 FXC05
- 2 W dimension (mm)
Refer to the below table

Installation example

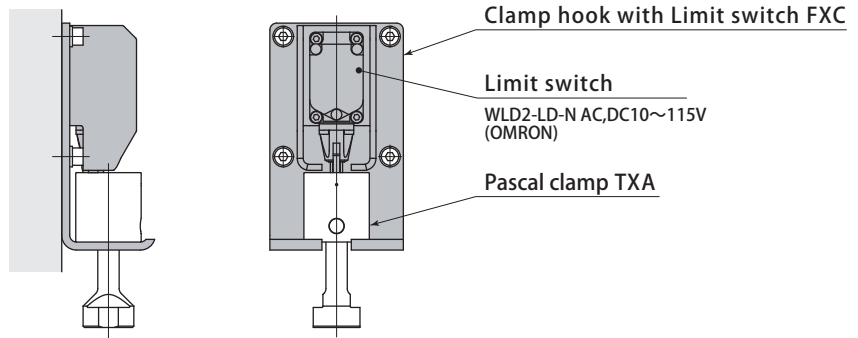

● Do not operate the machine with clamp hung on the clamp hook.

T-slot dimension

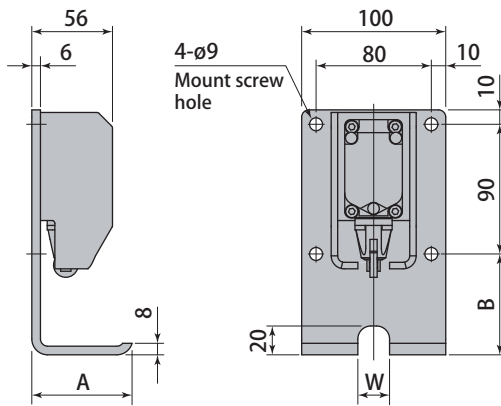
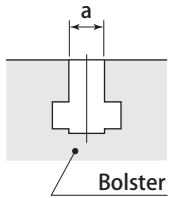

● The mount screw is not furnished. If necessary, order the mount screw type sold separately.

Mount screw

Hook type	Reference specification	Mount screw type (option)
FXC01	4-M8 length 16	FXC-A08
FXC02		
FXC03		
FXC04		
FXC05		

Clamp model	TXA010					TXA020					
	T-slot a	mm	Less than 14	15~18	19~22	23~28	Less than 14	15~18	19~22	23~28	29~34
Clamp hook type		FXC01-14	FXC01-18	FXC01-22	FXC01-28	FXC02-14	FXC02-18	FXC02-22	FXC02-28	FXC02-34	
W	mm	14	18	22	28	14	18	22	28	34	
A	mm	55					70				
G	mm	55					70				
Weight	kg	1.7					1.8				

Clamp model	TXA040					TXA063				TXA100				
	T-slot a	mm	Less than 14	15~18	19~22	23~28	29~34	Less than 22	23~28	29~34	35~40	Less than 22	23~28	29~34
Clamp hook type		FXC03-14	FXC03-18	FXC03-22	FXC03-28	FXC03-34	FXC04-22	FXC04-28	FXC04-34	FXC04-40	FXC05-22	FXC05-28	FXC05-34	FXC05-40
W	mm	14	18	22	28	34	22	28	34	40	22	28	34	40
A	mm	90					110				130			
G	mm	77					83				89			
Weight	kg	1.9					2.0				2.1			

Model designation

FX **D** **01** - **18** - **38**

- 1 Hook size
FXD01 FXD02 FXD03
- 2 W dimension (mm)
Refer to the below table
- 3 d+h dimension (mm)

Installation example of the upper type of clamp

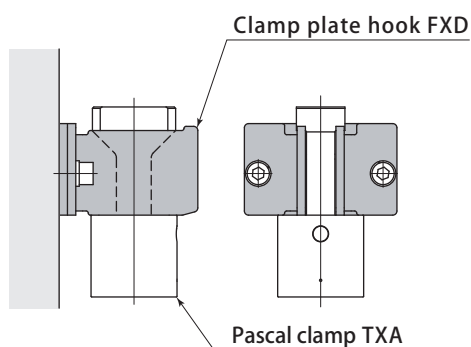

Installation example of the lower type of clamp

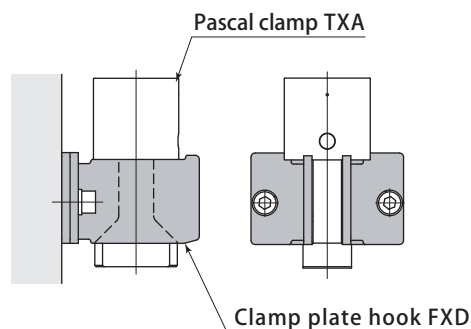

- The shape of the upper and lower type of hook is the same.
- The clamp plate which fixes the unused clamp outside machine is attached.

T-slot dimension

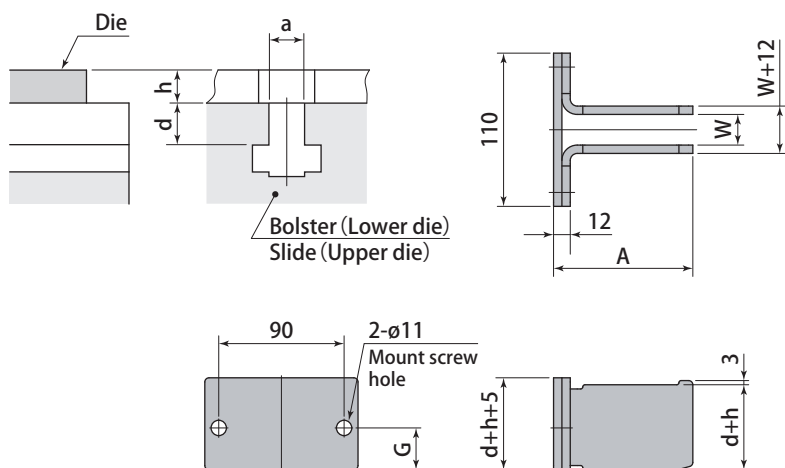

- The mount screw is not furnished. If necessary, order the mount screw type sold separately.

Mount screw

Hook type	Reference specification	Mount screw type (option)
FXD01	2-M10 length 30	FXD-A10
FXD02		
FXD03		

Clamp model	TXA010				TXA020 / TXA040					TXA063 / TXA100				
	T-slot a	mm	Less than 14	15~18	19~22	23~28	Less than 14	15~18	19~22	23~28	29~34	Less than 22	23~28	29~34
Clamp hook type		FXD01-14	FXD01-18	FXD01-22	FXD01-28	FXD02-14	FXD02-18	FXD02-22	FXD02-28	FXD02-34	FXD03-22	FXD03-28	FXD03-34	FXD03-40
W	mm	14	18	22	28	14	18	22	28	34	22	28	34	40
A	mm	60				100					125			
G	mm	22				30					30			
Wight (Approx) (Reference d+h dimension)	kg mm	0.6 (d+h=38)				1.1 (d+h=61)					1.6 (d+h=83)			

Model designation

FX E 01 - 18 - 38 - 11

- 1 Hook size
- 2 W dimension (mm)
- 3 d+h dimension (mm)
- 4 J dimension (mm)

- 1 Hook size
FXE01 FXE02 FXE03
FXE04 FXE05
- 2 W dimension (mm)
Refer to the below table.
- 3 d+h dimension (mm)
Refer to T-slot dimension.
- 4 J dimension (mm)

Installation example

● The clamp plate which fixes the unused clamp outside machine is attached.

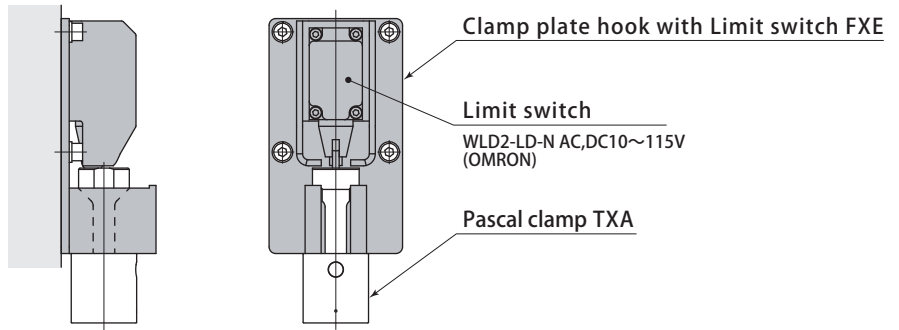

T-slot dimension

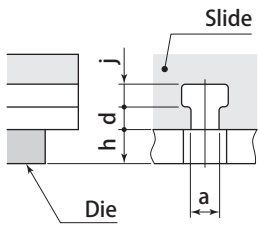

T-leg dimension

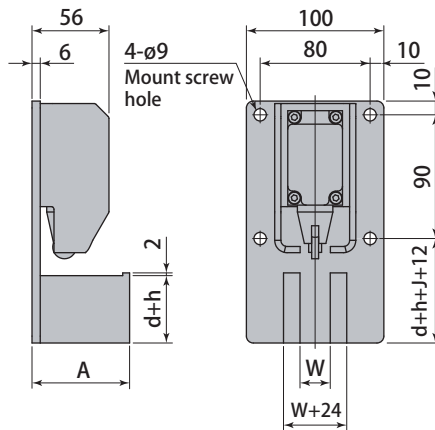
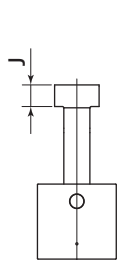

● The mount screw is not furnished. If necessary, order the mount screw type sold separately.

Mount screw

Hook type	Reference specification	Mount screw type (option)
FXE01	4-M8 length 16	FXE-A08
FXE02		
FXE03		
FXE04		
FXE05		

Clamp model	T-slot a	TXA010				TXA020				
		mm	Less than 14	15~18	19~22	23~28	Less than 14	15~18	19~22	23~28
Clamp hook type		FXE01-14	FXE01-18	FXE01-22	FXE01-28	FXE02-14	FXE02-18	FXE02-22	FXE02-28	FXE02-34
W	mm	14	18	22	28	14	18	22	28	34
A	mm	56				71				
Wight (Approx) (Reference d,h,J dimension)	kg mm	1.9 (d+h=38, J=11)				2.2 (d+h=49, J=15)				

Clamp model	T-slot a	TXA040					TXA063				TXA100			
		mm	Less than 14	15~18	19~22	23~28	29~34	Less than 22	23~28	29~34	35~40	Less than 22	23~28	29~34
Clamp hook type		FXE03-14	FXE03-18	FXE03-22	FXE03-28	FXE03-34	FXE04-22	FXE04-28	FXE04-34	FXE04-40	FXE05-22	FXE05-28	FXE05-34	FXE05-40
W	mm	14	18	22	28	34	22	28	34	40	22	28	34	40
A	mm	91					106				131			
Wight (Approx) (Reference d,h,J dimension)	kg mm	2.7 (d+h=61, J=17)					3.2 (d+h=73, J=19)				3.8 (d+h=83, J=19)			

Model designation

FX **F** **01** - **18** - **38**

- 1 Hook size
- 2 W dimension (mm)
- 3 d+h dimension (mm)

- 1 Hook size
FXF01 FXF02 FXF03
FXF04 FXF05
- 2 W dimension (mm)
Refer to the below table.
- 3 d+h dimension (mm)

Installation example

The clamp plate which fixes the unused clamp outside machine is attached.

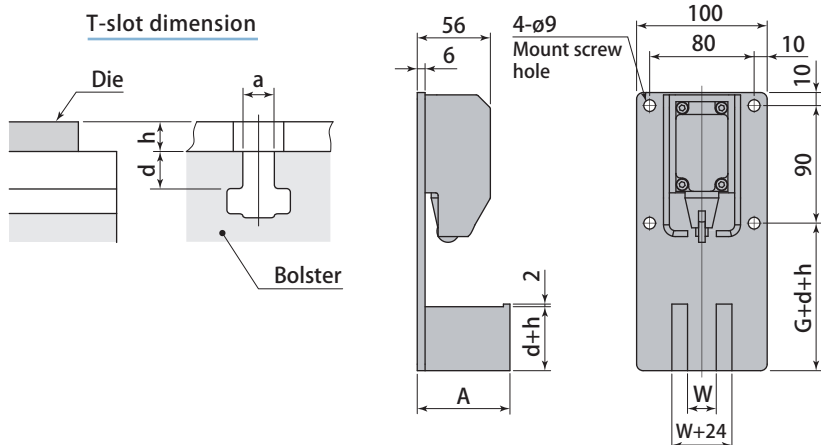
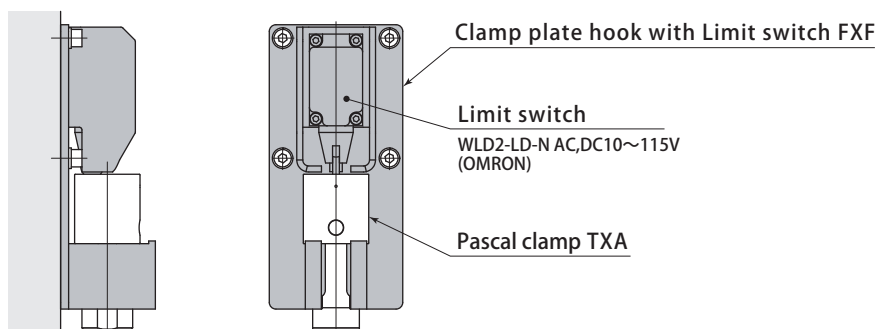

The mount screw is not furnished. If necessary, order the mount screw type sold separately.

Mount screw

Hook type	Reference specification	Mount screw type (option)
FXF01	4-M8 length 16	FXF-A08
FXF02		
FXF03		
FXF04		
FXF05		

Clamp model		TXA010				TXA020				
		Less than 14	15~18	19~22	23~28	Less than 14	15~18	19~22	23~28	29~34
T-slot a	mm									
Clamp hook type		FXF01-14	FXF01-18	FXF01-22	FXF01-28	FXF02-14	FXF02-18	FXF02-22	FXF02-28	FXF02-34
W	mm	14	18	22	28	14	18	22	28	34
A	mm	56				71				
G	mm	49				64				
Wight (Approx) (Reference d+h dimension)	kg mm	2.1 (d+h=38)				2.4 (d+h=49)				

Clamp model		TXA040					TXA063				TXA100			
		Less than 14	15~18	19~22	23~28	29~34	Less than 22	23~28	29~34	35~40	Less than 22	23~28	29~34	35~40
T-slot a	mm													
Clamp hook type		FXF03-14	FXF03-18	FXF03-22	FXF03-28	FXF03-34	FXF04-22	FXF04-28	FXF04-34	FXF04-40	FXF05-22	FXF05-28	FXF05-34	FXF05-40
W	mm	14	18	22	28	34	22	28	34	40	22	28	34	40
A	mm	91					106				131			
G	mm	71					77				83			
Wight (Approx) (Reference d+h dimension)	kg mm	2.9 (d+h=61)					3.4 (d+h=73)				4.0 (d+h=83)			

Pascal clamp model **TXC**

Pascal clamp automatic slidable type



Automatic slidable clamp with air cylinder. It enables to shorten the die exchange time.

Automatic slidable TXC

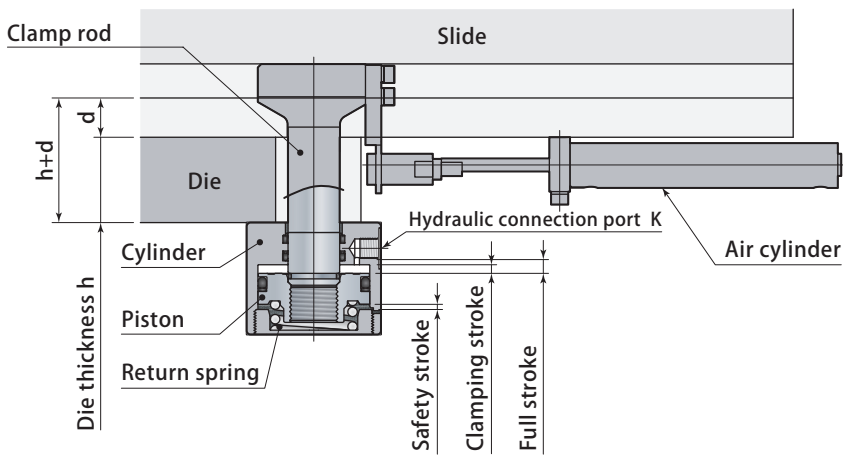

T-slot dimension and die thickness

U-cut dimension

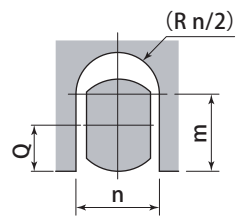
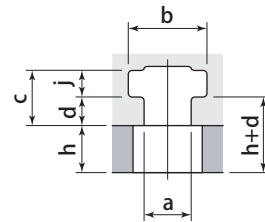

Specifications

Model	TXC020	TXC040	TXC063	TXC100	
Clamping force (at 24.5 MPa)	kN	19.6	39.2	61.7	98
Proof pressure	MPa	36.7			
Full stroke	mm	8			
Clamping stroke	mm	5			
Safety stroke	mm	3			
Cylinder capacity (at full stroke)	cm ³	6.5	13	21	32
Operating temperature	°C	0 ~ 70 (Standard)			
Approximate weight	kg	2	3	4	6
Range of dimension a	mm	18 ~ 28	22 ~ 32		28 ~ 36
Min. h	mm	30			40
Max. h+d	mm	80	90	100	110
Tolerance of dimension d	mm	± 0.2			
Tolerance of dimension j	mm	0 ~ +1			
Tolerance of dimension h	mm	± 0.3			
Min. m	mm	15	40	45	57
Range of dimension n	mm	22 ~ 30	22 ~ 35	22 ~ 40	28 ~ 50

- Working hydraulic pressure : 24.5MPa ● Weight varies according to the clamp rod dimension and sliding stroke.
- Specify T-slot dimensions a, b, d, j and die thickness h. For brand new machine, machine d, j and h dimension with the tolerance shown in the above table. For existing machine, specify tolerance of 0.1mm unit on d, j and h dimensions.
- In case dimension is over Max. h+d, refer to **page →56** Long clamp rod type. ● Stop the press during the clamp wait.

Model designation

TXC **040** **R** **0** **L** - **075**

- 1 Clamping force
- 2 Proximity switch
- 3 Mounting position of die detection proximity switch
- 4 Sliding stroke (mm)
* Indicated in 3 digits

- 1 Clamping force
TXC020 : 19.6kN
TXC040 : 39.2kN
TXC063 : 61.7kN
TXC100 : 98kN

2 Proximity switch

Symbol of proximity switch model	0	1	2	3
Specifications	DC24V 2-Wire	DC24V 3-Wire(NPN)	AC100V 2-Wire	DC24V 3-Wire(PNP)
Model	E2E-X7D1-N	E2E-X5E1	E2E-X5Y1	E2E-X5F1
Manufacturer name	OMRON			
Insulation vinyl cable length	5m			

3 Mounting position of die detection proximity switch



4 Sliding stroke

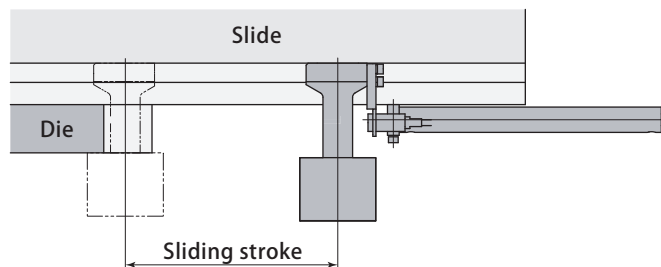

Model	TXC020R	TXC040R	TXC063R	TXC100R
Sliding stroke *	mm 50, 75, 100, 125, 150, 200	75, 100, 125, 150, 200	100, 125, 150, 200	100, 150, 200
Air cylinder driven pressure	MPa 0.39 ~ 0.54			
Slide velocity	mm/s 30 ~ 1000 (to be adjusted by a flow control valve)			
Air cylinder model	CG1BN20-□			CG1BN32-□
Air cylinder manufacturer	SMC			

● Refer to **page →54** for the details of sliding stroke.

* Contact Pascal for the sliding stroke which is not mentioned above.

Unclamp

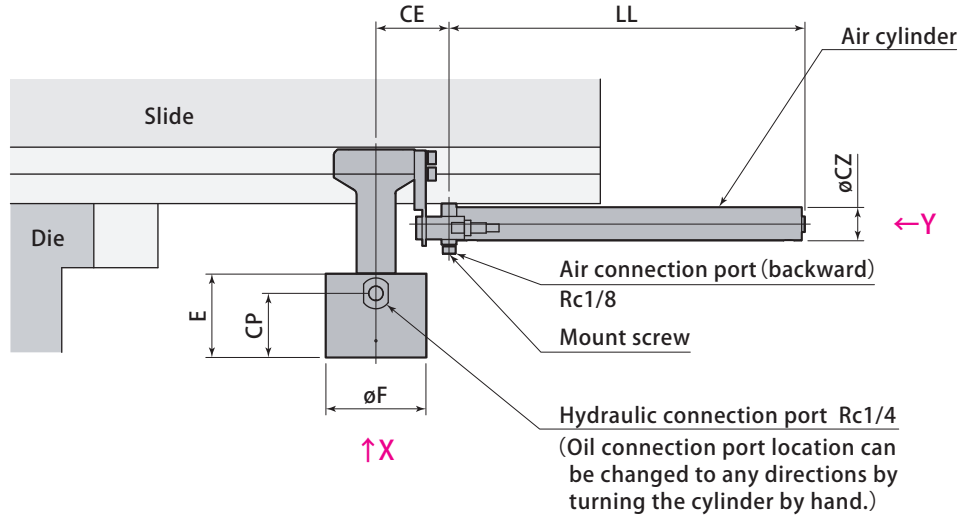

Clamp

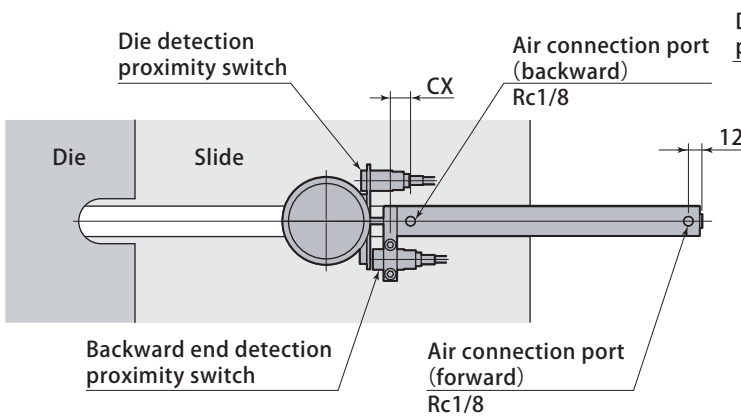
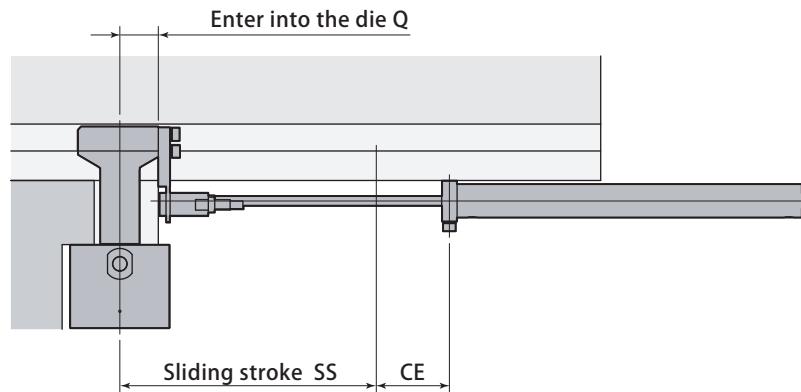

VIEW : X

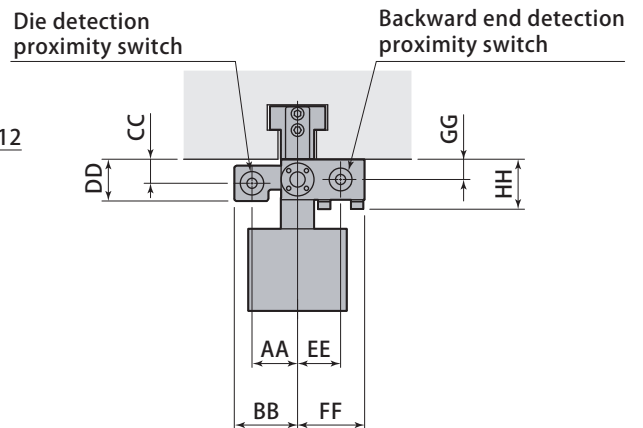

VIEW : Y

● These drawings indicate : mounting position of proximity switch **L**

Dimensions

Model	mm			
	TXC020R	TXC040R	TXC063R	TXC100R
øCZ	26	26	26	38
øF	49	62	78	98
CP	40	45.5	50	55
E	52	59	65	71
CE	42	54	57	64
CX	18	18	18	20
Q	15	27	30	37
HH	39.5	39.5	39.5	54
GG	16	16	16	22
CC	19	19	19	20
EE	34	34	34	39.5
AA	36	36	36	43
FF	53	53	53	54
BB	50.5	50.5	50.5	57.5
DD	33	33	33	34
Mount screw	4-M6 length 40	4-M6 length 40	4-M6 length 40	4-M8 length 55

Sliding stroke 50 75 100 125 150 200 mm

Sliding stroke SS	mm			
	TXC020R	TXC040R	TXC063R	TXC100R
	Overall length LL			
50	127	—	—	—
75	152	152	—	—
100	177	177	177	181
125	202	202	202	206
150	227	227	227	231
200	277	277	277	281

Mounting details

TXC020R TXC040R TXC063R

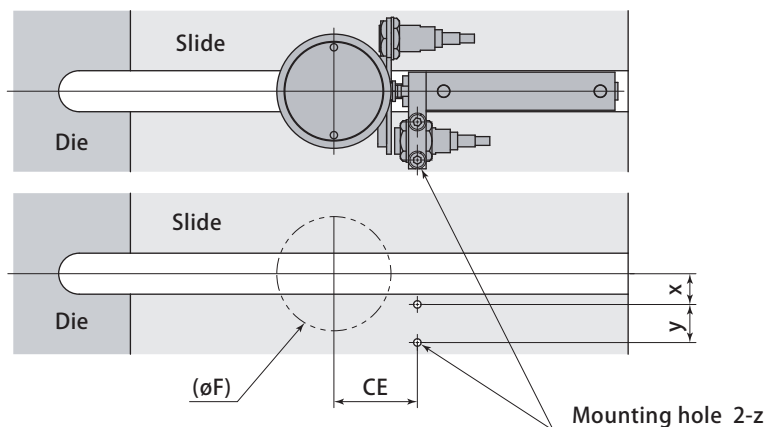

● This drawing indicates : mounting position of proximity switch L

TXC100R

The mounting hole position is the same between TXC100RL□ and TXC100RR□.

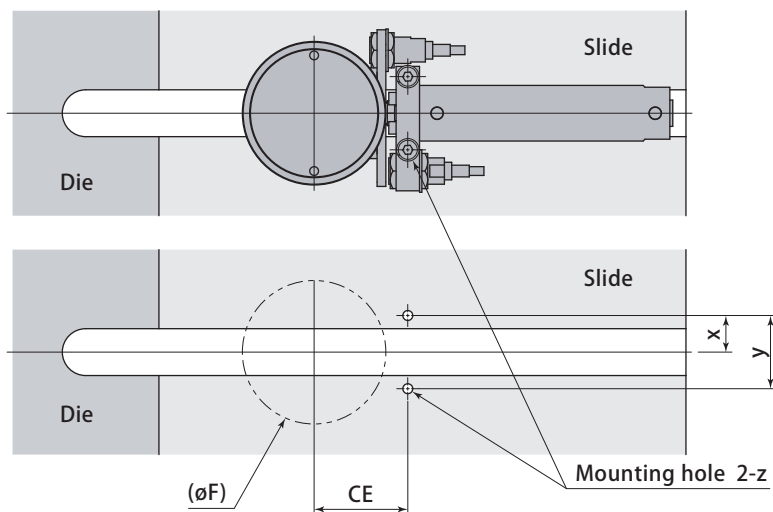

mm

Model	TXC020R	TXC040R	TXC063R	TXC100R
øF	49	62	78	98
CE	42	54	57	64
x	21	21	21	25
y	26	26	26	50
z	M6 depth 12	M6 depth 12	M6 depth 12	M8 depth 16

H Long clamp rod type It is applied in case the die thickness is over the standard.

Model designation

TXC **040** R **0** **L** - **075** - **H**

- 1 Clamping force
 - 2 Proximity switch
 - 3 Mounting position of die detection proximity switch
 - 4 Sliding stroke (mm) * Indicated in 3 digits
- 1 2 3 4 Refer to page →52

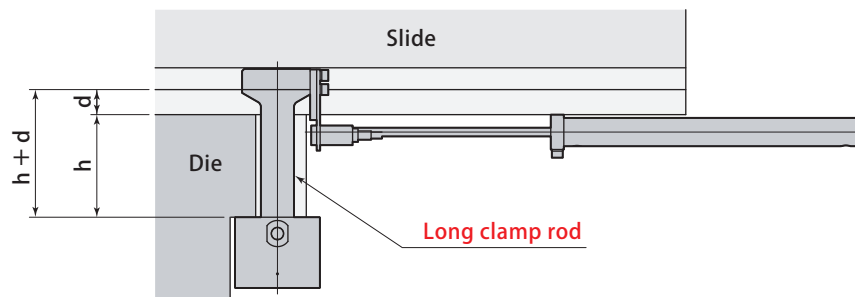

Model	TXC020R	TXC040R	TXC063R	TXC100R
h+d	h+d > 80	h+d > 90	h+d > 100	h+d > 110

mm

V Heat proof type It is applied under condition that the die and its surroundings are in high temperature.

Model designation

TXC **040** R **0** **L** - **075** - **V**

- 1 Clamping force
 - 2 Proximity switch
 - 3 Mounting position of die detection proximity switch
 - 4 Sliding stroke (mm) * Indicated in 3 digits
- 1 2 3 4 Refer to page →52

● The operating ambient temperature of heat proof type is 5-120°C.

Pascal clamp model TXE

Pascal clamp automatic solidable type model TXE

which utilizes the entire lower surface.



Automatic slidable clamp which utilizes **the entire** lower surface.



Specifications

Model		TXE020	TXE040	TXE063	TXE100
Clamping force (at 24.5 MPa)	kN	19.6	39.2	61.7	98
Proof pressure	MPa	36.7			
Full stroke	mm	8			
Clamping stroke	mm	5			
Safety stroke	mm	3			
Cylinder capacity (at full stroke)	cm ³	6.5	13	21	32
Operating temperature	°C	0 ~ 70 (Standard)			
Approximate weight	kg	4	5	6	9
Range of dimension a	mm	18 ~ 28	22 ~ 32		28 ~ 36
Min. h	mm	30			40
Max. h+d	mm	80	90	100	110
Tolerance of dimension d	mm	± 0.2			
Tolerance of dimension j	mm	0 ~ +1			
Tolerance of dimension h	mm	± 0.3			
Min. m	mm	15	40	45	57
Range of dimension n	mm	22 ~ 30	22 ~ 35	22 ~ 40	28 ~ 50

- Working hydraulic pressure : 24.5MPa
- Weight varies according to clamp rod dimension and existence or non-existence of sliding stroke and clamp plate.
- Specify T-slot dimensions a, b, d, j and die thickness h. For brand new machine, machine d, j and h dimensions with the tolerance shown in the above table. For existing machine, specify tolerance of 0.1mm unit on d, j and h dimensions.
- In case dimension is over Max. h+d, refer to **page** → 72 Long clamp rod type.
- Stop the press during the clamp wait.

Home clamp

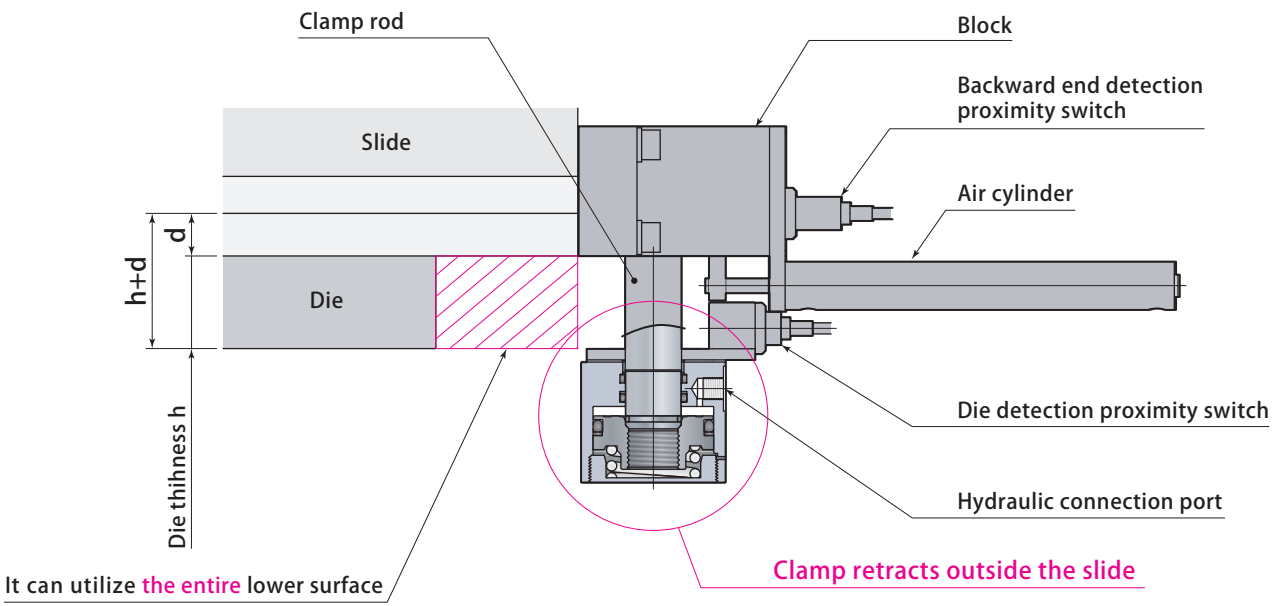

Clamp

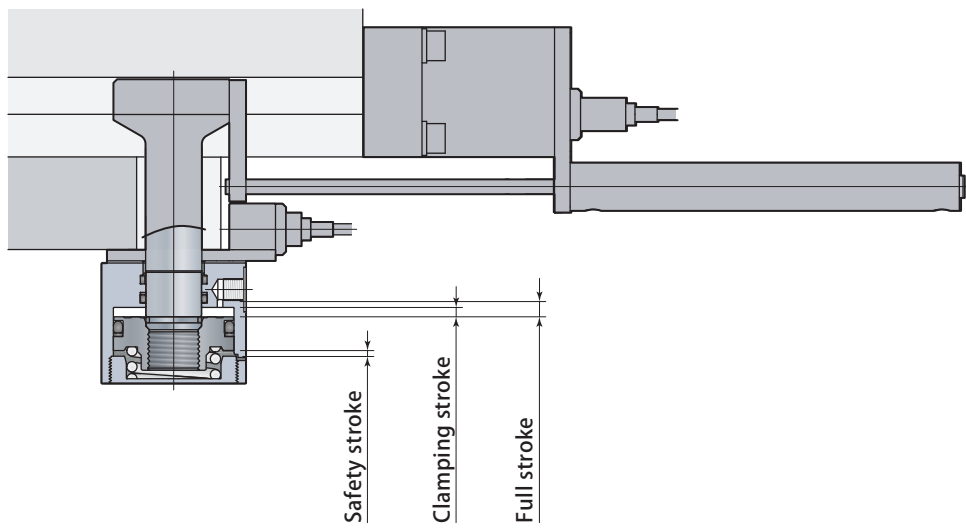

T-slot dimension and die thickness

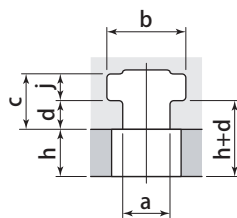

U-cut dimension

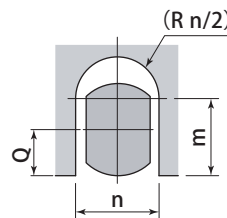

Model designation

TXE 063 C 0 L - 090

- 1 Clamping force
- 2 Clamp plate
Mounting bracket
- 3 Proximity switch
- 4 Mounting position
of die detection proximity switch
- 5 Sliding stroke (mm) * Indicated in 3 digits

- 1 Clamping force
TXE020 : 19.6kN
TXE040 : 39.2kN
TXE063 : 61.7kN
TXE100 : 98kN

2 Clamp plate, Mounting bracket

Symbol of clamp plate and mounting bracket model	B	C	D	E
Clamp plate	No attached	Attached	No attached	Attached
Mounting bracket	No attached	No attached	Attached	Attached

The clamp plate is necessary, in case each die varies to number of used clamps.

Clamping the small sized die

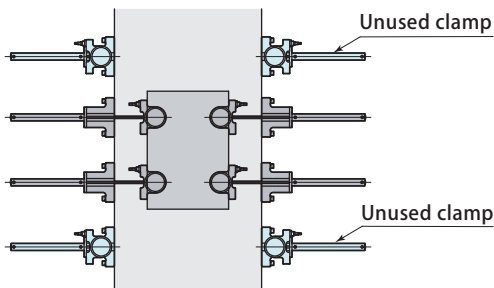

Clamping the large sized die

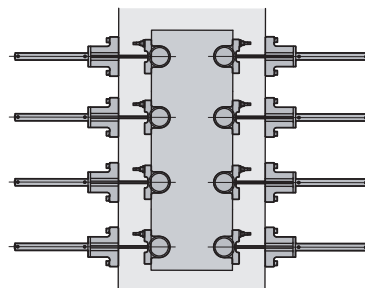

- If the unused clamps are forced to wait and the press is operated, the connecting part will be damaged by vibration. Therefore, specify the clamp plate and let them wait in status of clamping.

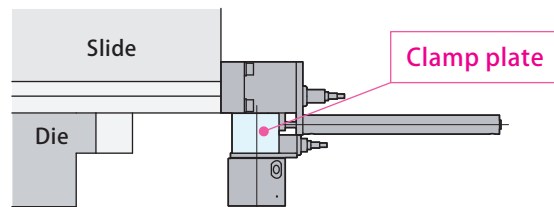

In case the sliding stroke is over 200mm, mounting bracket is necessary.

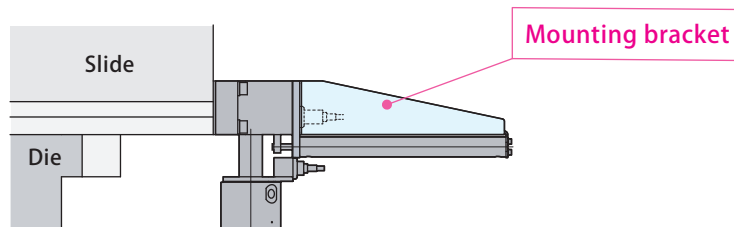

3 Proximity switch

Symbol of proximity switch model	0	1	2	3
Specifications	DC24V 2-Wire	DC24V 3-Wire(NPN)	AC100V 2-Wire	DC24V 3-Wire(PNP)
Model	E2E-X7D1-N	E2E-X5E1	E2E-X5Y1	E2E-X5F1
Manufacturer name	OMRON			
Insulation vinyl cable length	5m			

4 Mounting position of die detection proximity switch

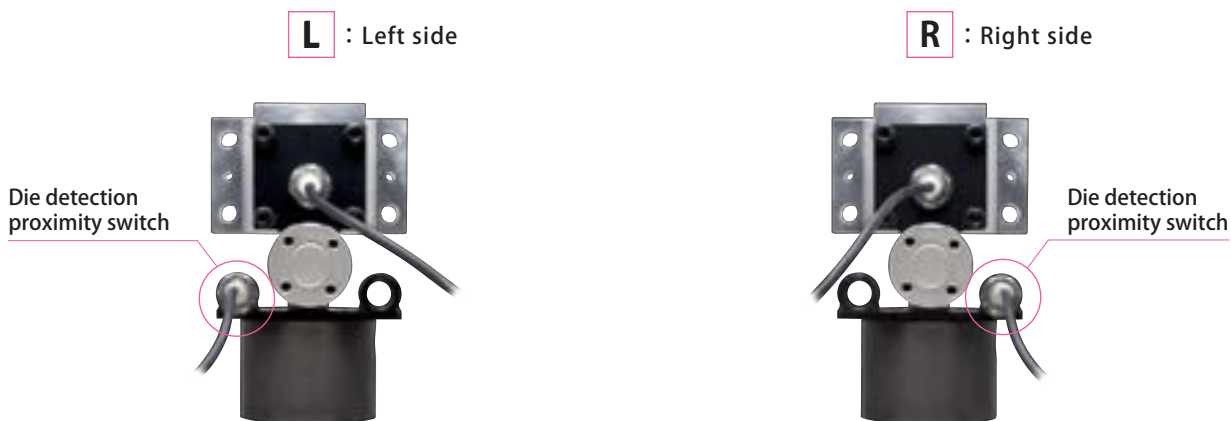

5 Sliding stroke

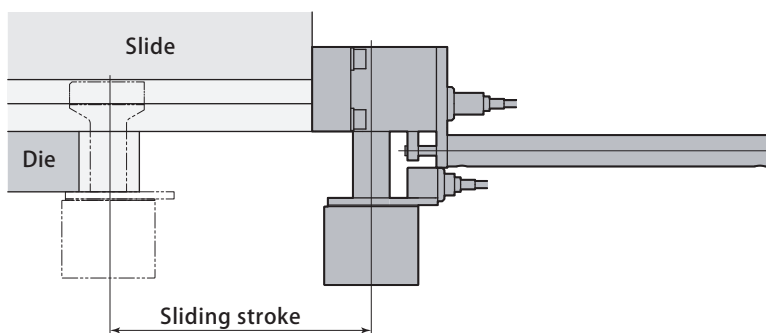

Model	TXE020	TXE040	TXE063	TXE100
Sliding stroke *	mm 50, 75, 100, 125, 150, 200, 250, 300	75, 100, 125, 150, 200, 250, 300	100, 125, 150, 200, 250, 300	100, 125, 150, 200, 250, 300
Air cylinder driven pressure	MPa	0.39 ~ 0.54		
Slide velocity	mm/s	30 ~ 100 (to be adjusted by a flow control valve)		
Air cylinder model		CG1BN20-□		CG1BN32-□
Air cylinder manufacturer		SMC		

● Refer to **pages →64 ~ 70** for the details of sliding stroke.

* Contact Pascal for the sliding stroke which is not mentioned above.

Home clamp

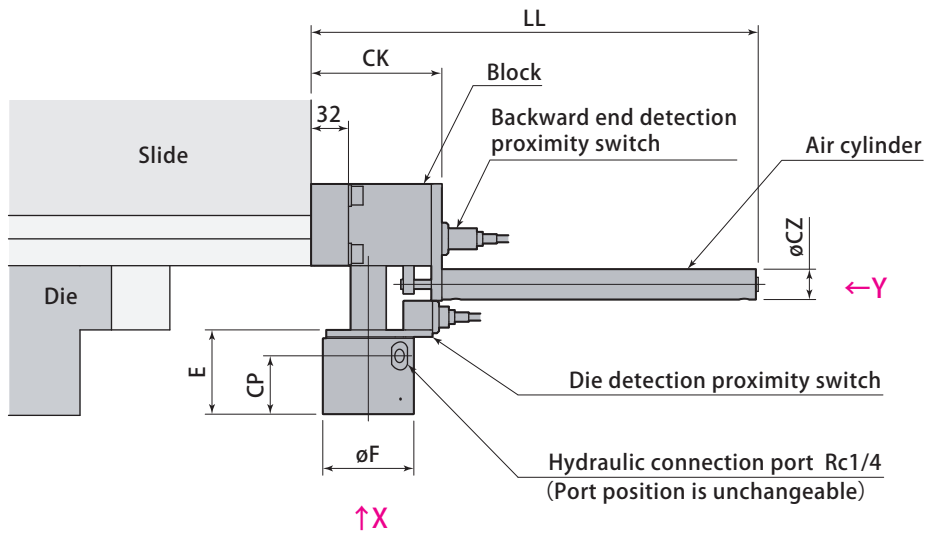

Clamp

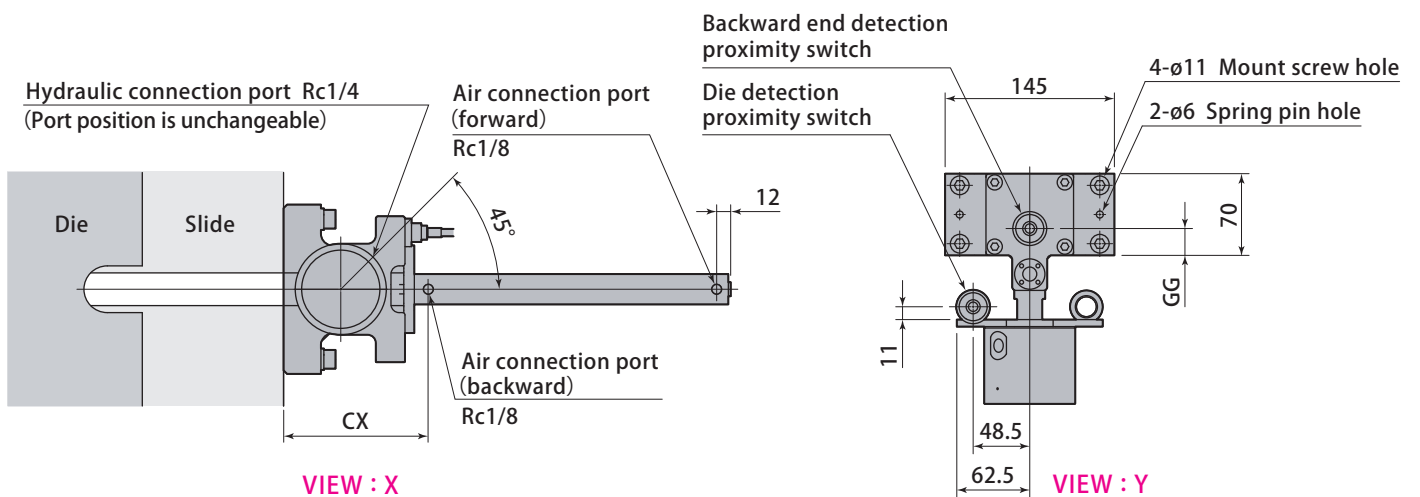
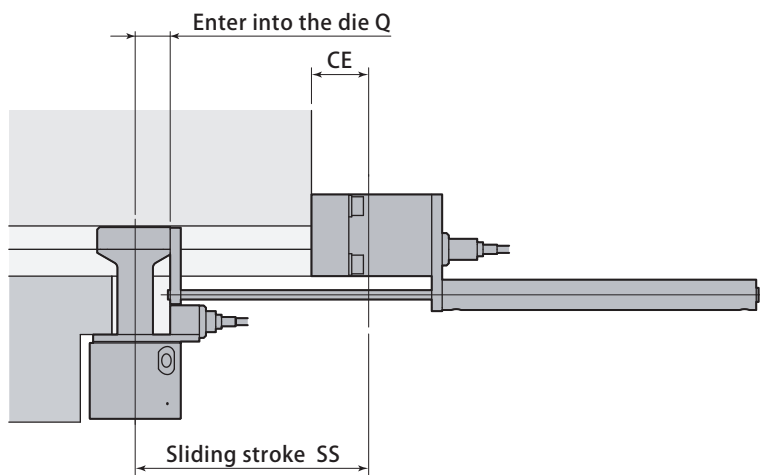

● These drawings indicate : mounting position of proximity switch L

B Clamp plate : no attached
Mounting bracket : no attached

Model designation

TXE **040** **B** **0** **L** - **075**

- 1 Clamping force
- 3 Proximity switch
- 4 Mounting position of die detection proximity switch
- 5 Sliding stroke (mm) *Indicated in 3 digits

1 3 4 Refer to pages → 61 ~ 62

5 Sliding stroke 50 75 100 125 150 200 mm

Sliding stroke SS	TXE020B	TXE040B	TXE063B	TXE100B
	Overall length LL			
50	203.5	—	—	—
75	228.5	247	—	—
100	253.5	272	283	304
125	278.5	297	308	329
150	303.5	322	333	354
200	353.5	372	383	404

External dimension

Model	TXE020B	TXE040B	TXE063B	TXE100B
∅CZ	26	26	26	38
∅F	49	62	78	98
CP	40	45.5	50	55
E	67	71	75.5	81.5
CK	82.5	101	112	131
CX	94.5	113	124	143
CE	34.5	41	49	59
Q	15	27	30	37
GG	23	23	23	29
Mount screw	4-M10 length 50			
Spring washer	4-M10			
Spring pin	2-∅6 length 45			

Home clamp

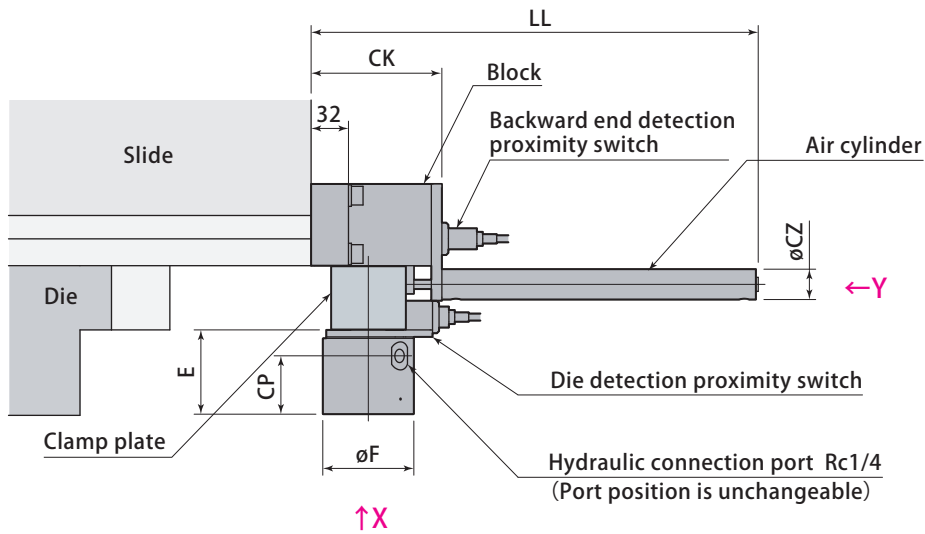

Clamp

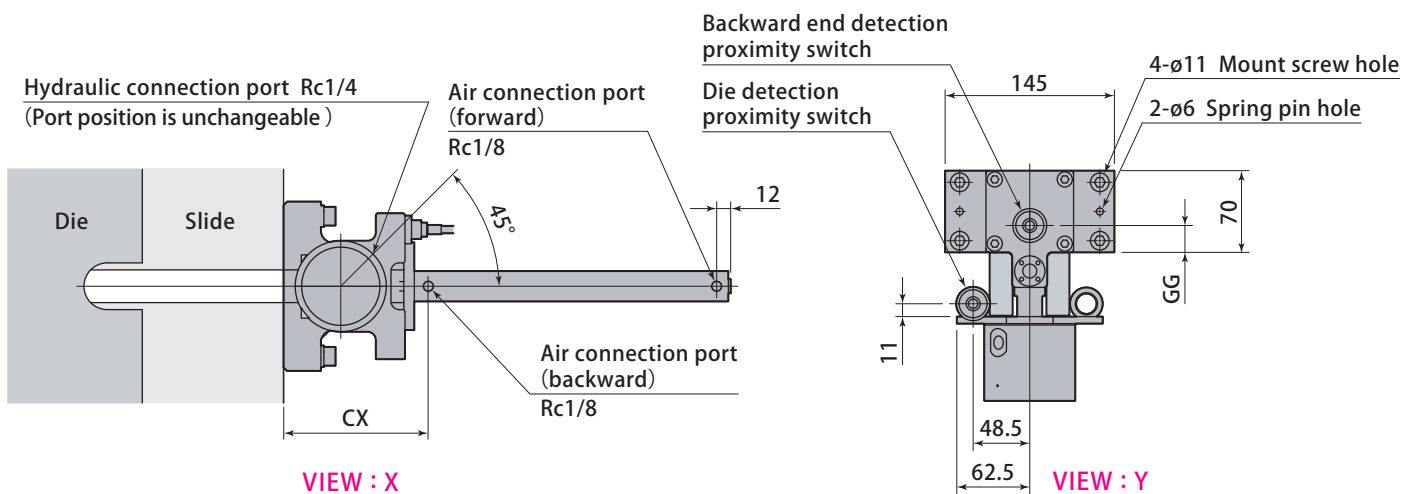
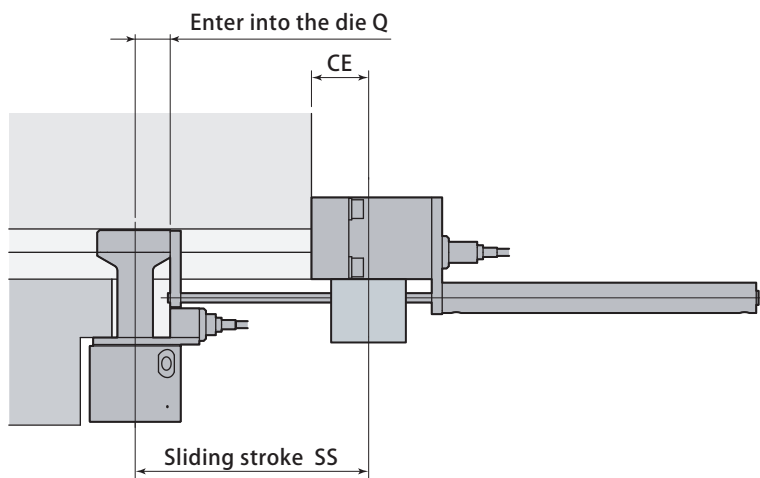

● These drawings indicate : mounting position of proximity switch **L**

C Clamp plate : attached
Mounting bracket : no attached

Model designation

TXE **040** **C** **0** **L** - **075**

- 1 Clamping force
- 3 Proximity switch
- 4 Mounting position of die detection proximity switch
- 5 Sliding stroke (mm) * Indicated in 3 digits

1 3 4 Refer to pages → 61 ~ 62

5 Sliding stroke 50 75 100 125 150 200 mm

Sliding stroke SS	TXE020C	TXE040C	TXE063C	TXE100C
	Overall length LL			
50	203.5	—	—	—
75	228.5	247	—	—
100	253.5	272	283	304
125	278.5	297	308	329
150	303.5	322	333	354
200	353.5	372	383	404

External dimension

Model	TXE020C	TXE040C	TXE063C	TXE100C
øCZ	26	26	26	38
øF	49	62	78	98
CP	40	45.5	50	55
E	67	71	75.5	81.5
CK	82.5	101	112	131
CX	94.5	113	124	143
CE	34.5	41	49	59
Q	15	27	30	37
GG	23	23	23	29
Mount screw	4-M10 length 50			
Spring washer	4-M10			
Spring pin	2-ø6 length 45			

Home clamp

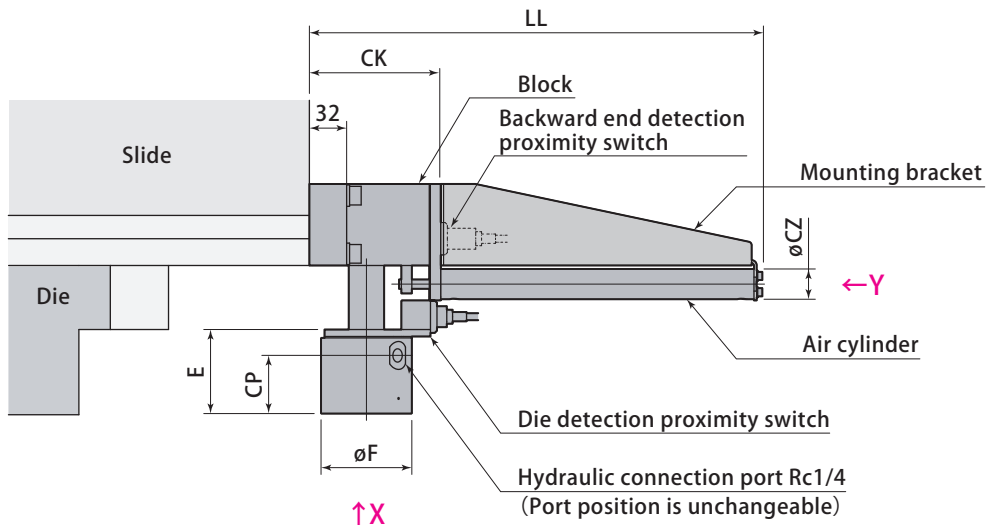

Clamp

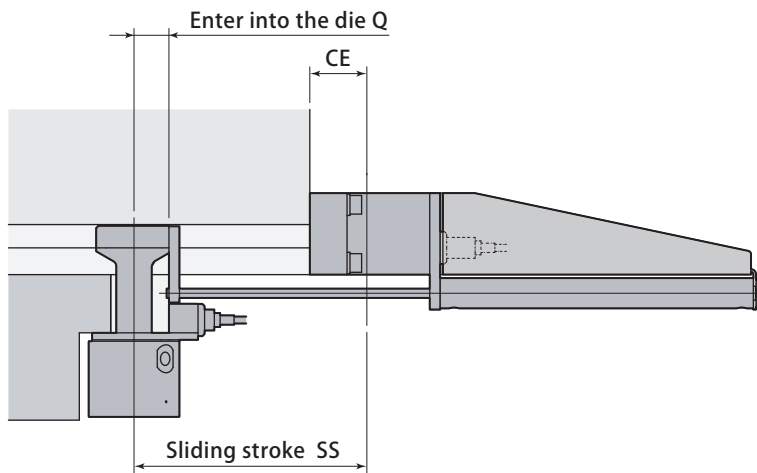

Hydraulic connection port Rc1/4
(Port position is unchangeable)

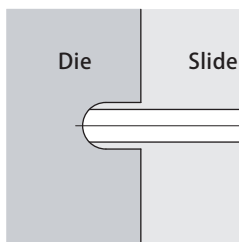

VIEW : X

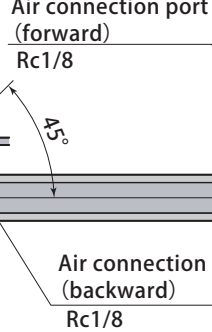

Backward end detection proximity switch
Die detection proximity switch

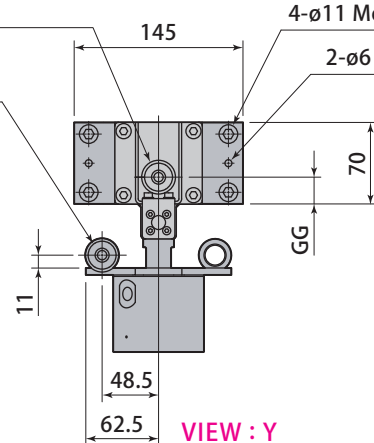

VIEW : Y

● These drawings indicate : mounting position of proximity switch **L**

D Clamp plate : no attached
Mounting bracket : attached

Model designation

TXE **063** **D** **0** **L** - **250**

- 1 Clamping force
- 3 Proximity switch
- 4 Mounting position of die detection proximity switch
- 5 Sliding stroke (mm) * Indicated in 3 digits

1 3 4 Refer to pages → 61 ~ 62

5 Sliding stroke 250 300 mm

Sliding stroke SS	TXE020D	TXE040D	TXE063D	TXE100D
	Overall length LL			
250	417	435	446	461
300	467	485	496	511

mm

External dimension

Model	TXE020D	TXE040D	TXE063D	TXE100D
∅CZ	26	26	26	38
∅F	49	62	78	98
CP	40	45.5	50	55
E	67	71	75.5	81.5
CK	82.5	101	112	131
CX	94.5	113	124	143
CE	34.5	41	49	59
Q	15	27	30	37
GG	23	23	23	29
CY	19.2	19.2	19.2	18.6
Mount screw	4-M10 length 50			
Spring washer	4-M10			
Spring pin	2-∅6 length 45			

mm

Home clamp

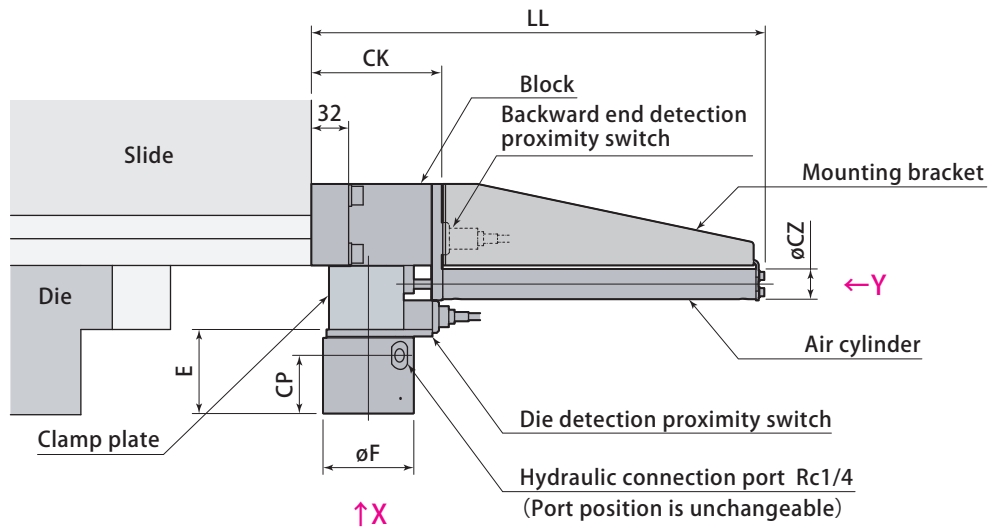

Clamp

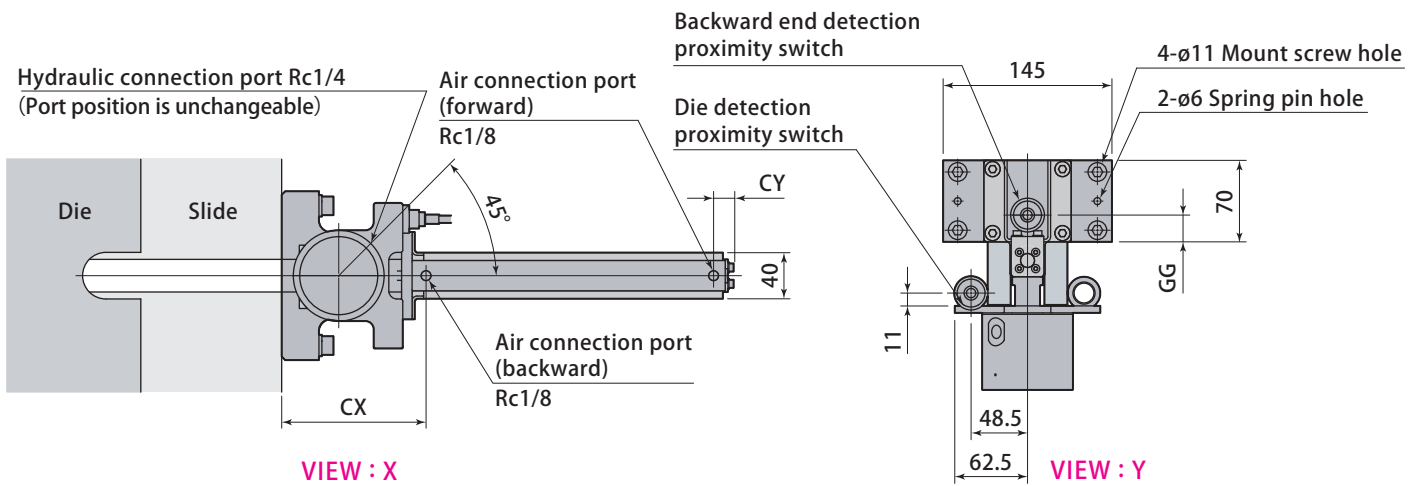
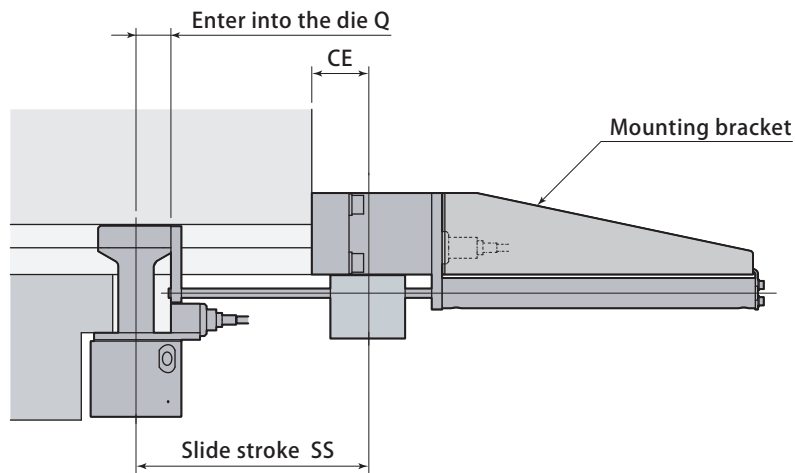

● These drawings indicate : mounting position of proximity switch L

E Clamp plate : attached
Mounting bracket : attached

Model designation

TXE **063** **E** **0** **L** - **250**

- 1 Clamping force
- 3 Proximity switch
- 4 Mounting position of die detection proximity switch
- 5 Sliding stroke (mm) * Indicated in 3 digits

1 3 4 Refer to pages → 61 ~ 62

5 Sliding stroke 250 300 mm

Sliding stroke SS	TXE020E	TXE040E	TXE063E	TXE100E
	Overall length LL			
250	417	435	446	461
300	467	485	496	511

External dimension

Model	TXE020E	TXE040E	TXE063E	TXE100E
∅CZ	26	26	26	38
∅F	49	62	78	98
CP	40	45.5	50	55
E	67	71	75.5	81.5
CK	82.5	101	112	131
CX	94.5	113	124	143
CE	34.5	41	49	59
Q	15	27	30	37
GG	23	23	23	29
CY	19.2	19.2	19.2	18.6
Mount screw	4-M10 length 50			
Spring washer	4-M10			
Spring pin	2-∅6 length 45			

Mounting details

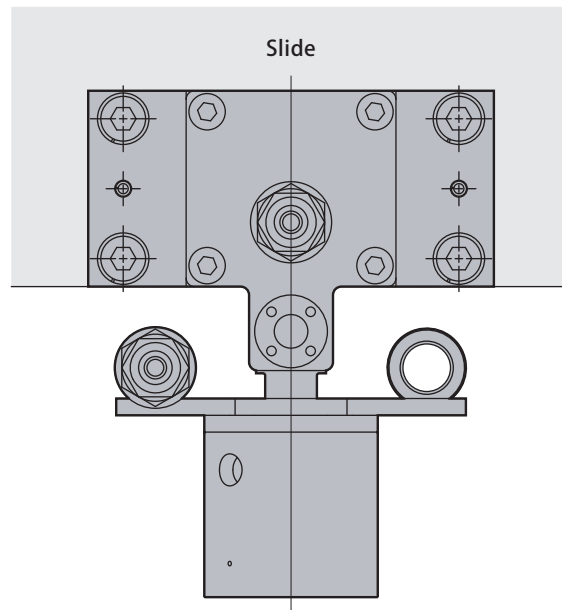

Block mounting hole
2-6 depth12
(Co-machining after gauging)

Block mounting hole
4-M10 depth20

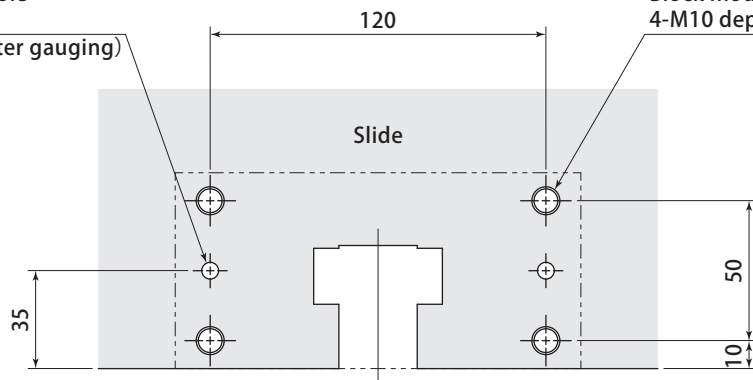

H Long clamp rod type It is applied in case the die thickness is over the standard.

Model designation

TXE 040 C 0 L - 075 - H

- 1 Clamping force
- 2 Clamp plate
Mounting bracket
- 3 Proximity switch
- 4 Mounting position
of die detection proximity switch
- 5 Sliding stroke (mm)

1 2 3 4 5 Refer to pages → 61 ~ 62

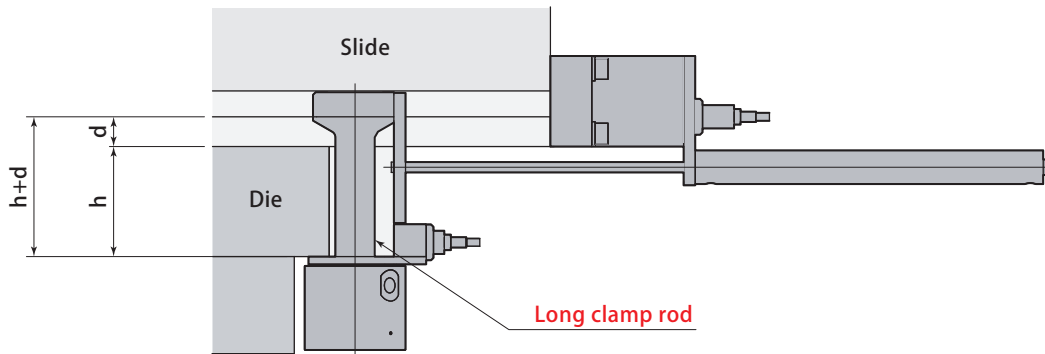

Model	TXE020	TXE040	TXE063	TXE100
$h+d$	$h+d > 80$	$h+d > 90$	$h+d > 100$	$h+d > 110$

mm

V Heat proof type It is applied under condition that the die and its surroundings are in high temperature.

Model designation

TXE 040 C 0 L - 075 - V

- 1 Clamping force
- 2 Clamp plate
Mounting bracket
- 3 Proximity switch
- 4 Mounting position
of die detection proximity switch
- 5 Sliding stroke (mm)

1 2 3 4 5 Refer to pages → 61 ~ 62

● The operating ambient temperature of heat proof type is 5-120°C.

traveling clamp model **TRX**

Compact, vibration-resistant automatic slidable clamp

Short stroke Motor driven



Vibration-resistant type
Applicable for high tensile stamping

Compact and neatly outlined body

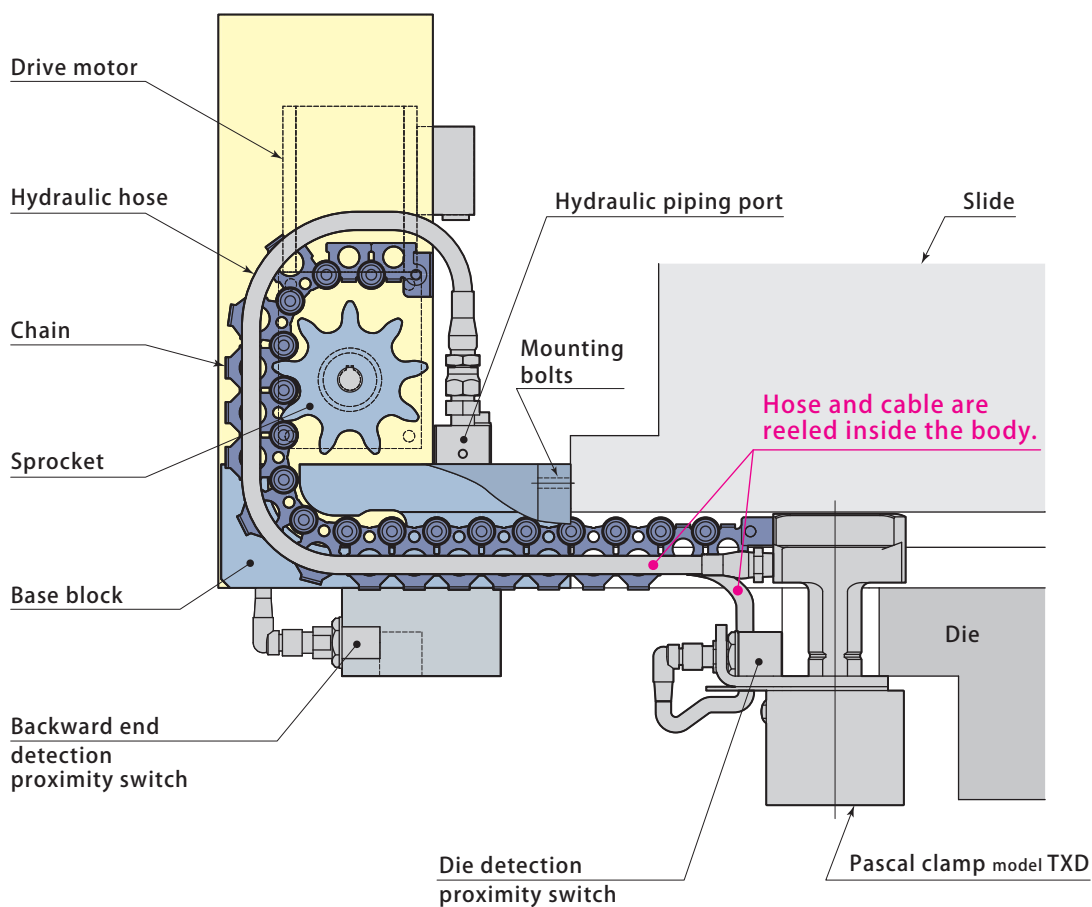

Specifications

Model		TRX040-0200	TRX040-0300	TRX063-0200	TRX063-0300
Traveling stroke	mm	200	300	200	300
Traveling speed (50/60Hz)	mm/sec.	85/104		85/104	
Clamping force (at 24.5 MPa)	kN	39.2		61.7	
Full stroke	mm	8		8	
Clamping stroke	mm	4		4	
Safety stroke	mm	4		4	
Cylinder capacity (at full stroke)	cm ³	13		21	
Approximate weight	kg	16		17	

- Working hydraulic pressure : 24.5MPa
- Fluid used : General mineral based hydraulic oil (ISO-VG32 equivalent)
- Operating temperature : -10 ~ 50°C (No frozen)
- Weight varies according to the die thickness and dimension of clamp rod.

Model designation

TRX 040 – 0200 L

- 1 Clamp Model * Indicated in 3 digits •
- 2 Traveling stroke * Indicated in 4 digits •
- 3 Mounting position of drive motor, terminal box and proximity switch •

1 Clamp Model * Indicated in 3 digits

- 040 : model TXD040 (Clamping force 39.2kN)
- 063 : model TXD063 (Clamping force 61.7kN)

2 Traveling stroke * Indicated in 4 digits

- 0200 : 200 mm 0300 : 300 mm

3 Mounting position of drive motor, terminal box and proximity switch

- L : As shown in the below diagram R : Mirror image of L

TRX – L

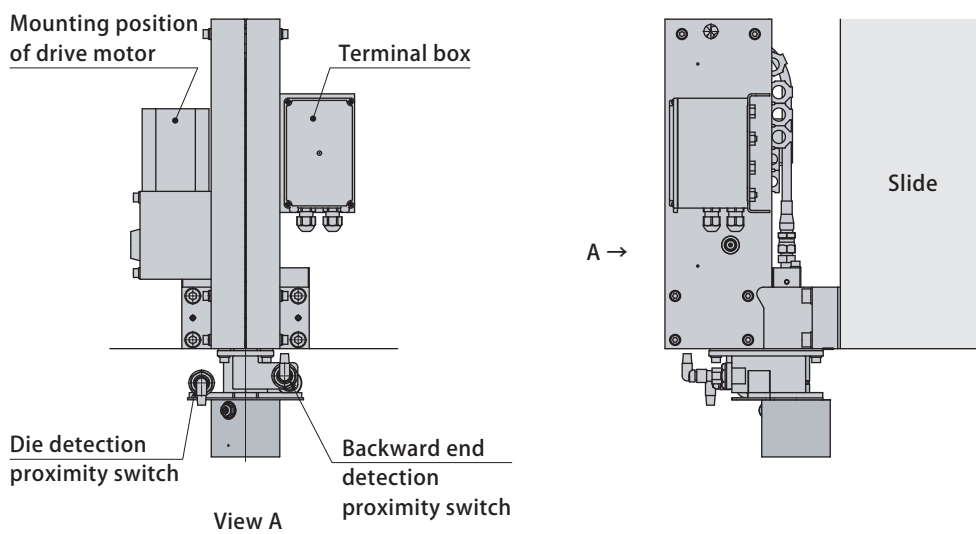

Piping/wiring looks nicer than that of model TXE or TXC

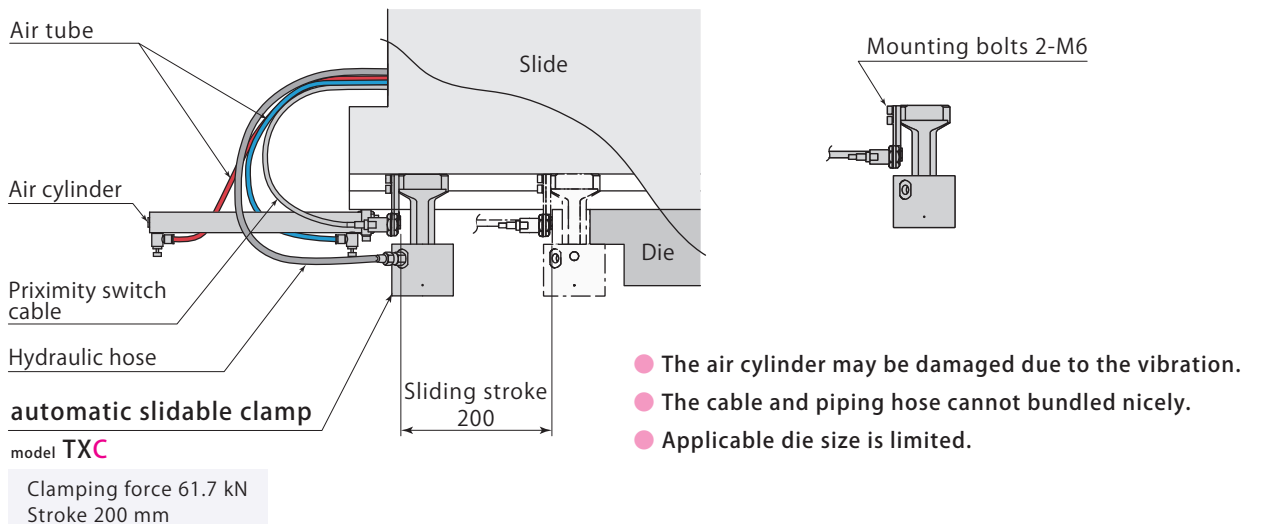
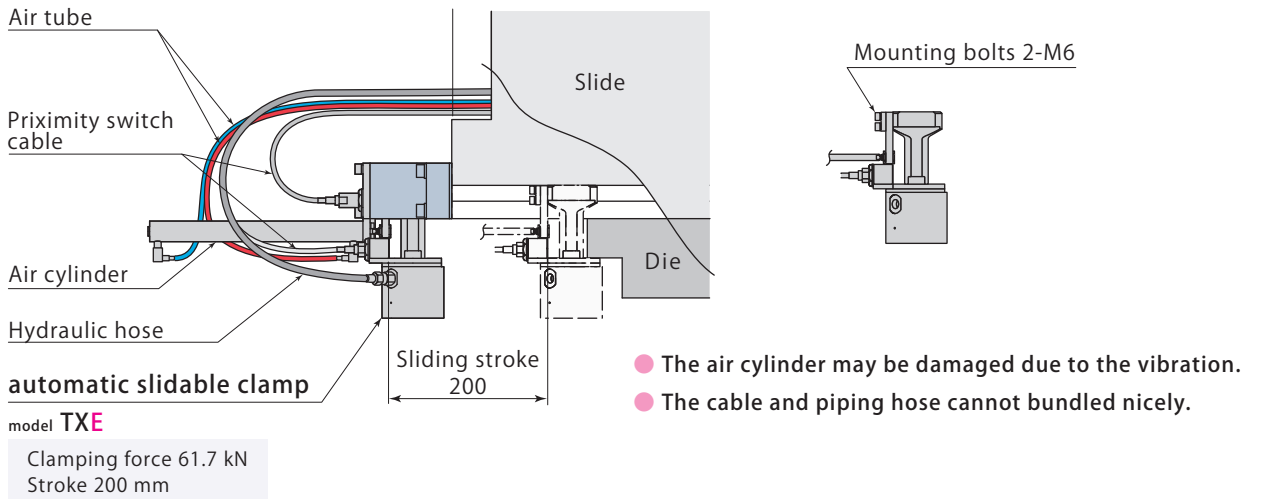
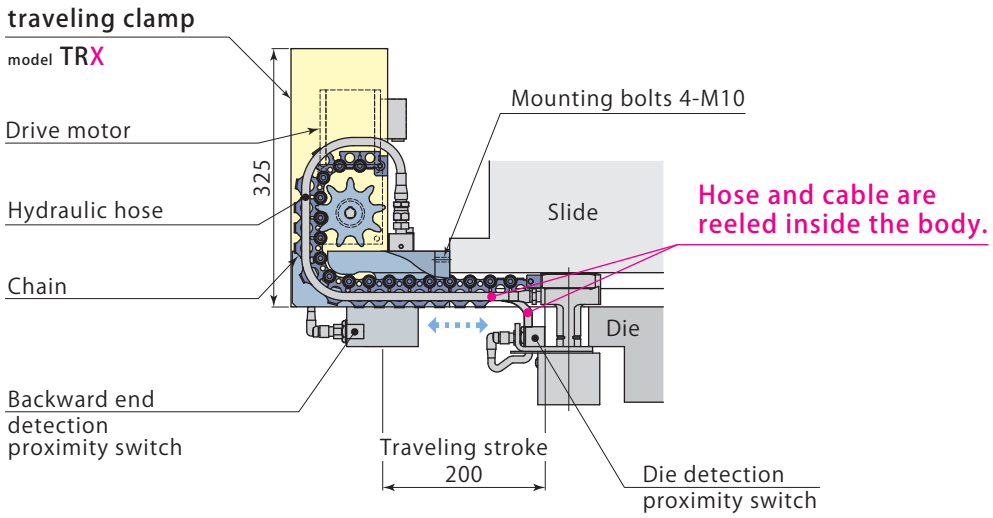

Distance from the mount face is shorter than that of model TXE or TXC

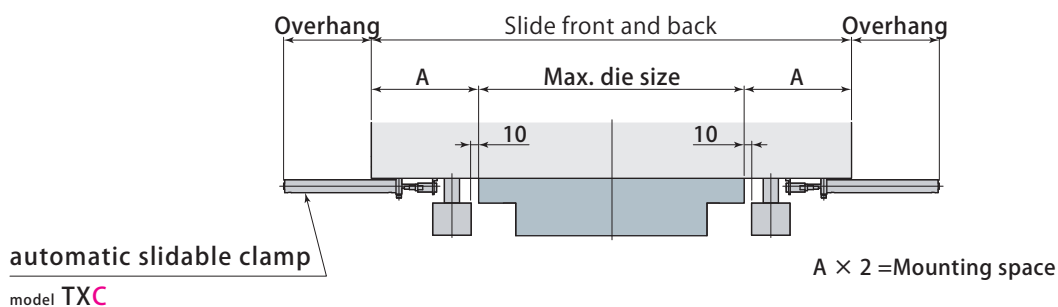
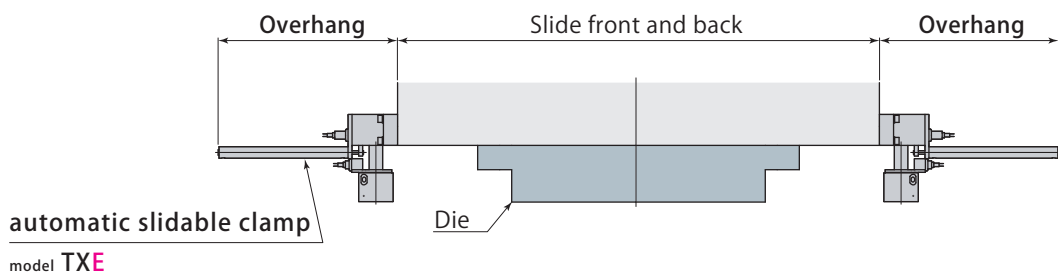
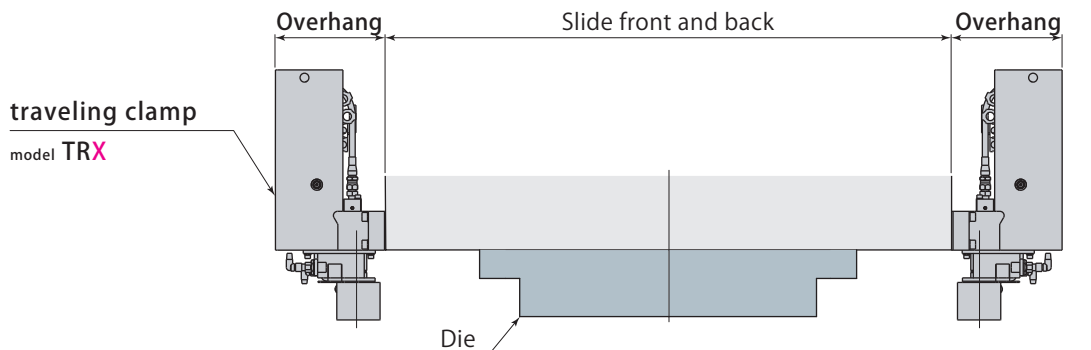

Overhang(for stroke 200mm)

Clamp size (Clamping force (at 24.5 MPa))	kN	040 (39.2)	063 (61.7)
TRX	mm	200	
TXE	mm	372	383
TXC	mm	222	233

TXC mounting space (Above figure A x2)

Clamp size (Clamping force (at 24.5 MPa))	kN	040 (39.2)	063 (61.7)
Mounting space (for 2 pcs of clamps)	mm	210	232

Installation period can be shortened compared to the model TXE

Automatic slidable type

model TXE 8 pcs

Traveling stroke

model TRX 8 pcs

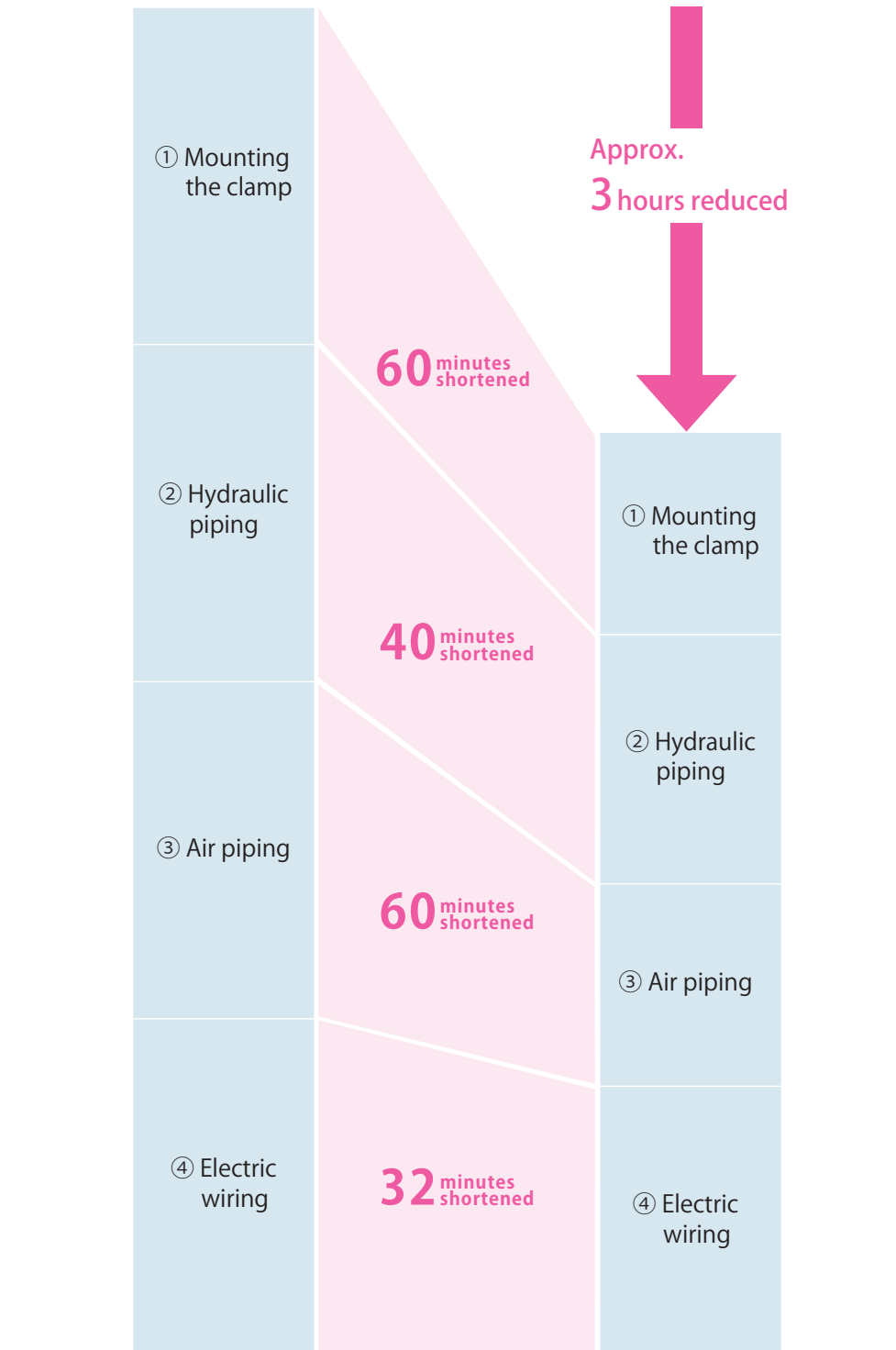

Dimensions

TRX **063** **0200** **L**

• Mounting position of drive motor, terminal box and proximity switch

L : As shown in the below diagram

R : Mirror image of L

2 Traveling stroke

0200 : 200 mm

0300 : 300 mm

1 Clamp Model

040 : model TXD040 (Clamping force 39.2 kN)

063 : model TXD063 (Clamping force 61.7 kN)

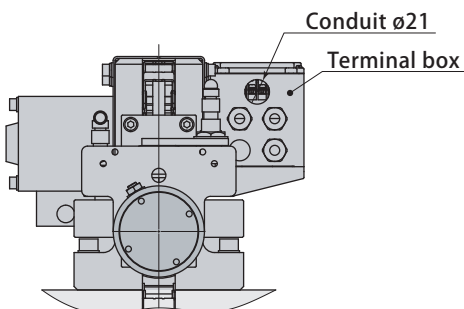
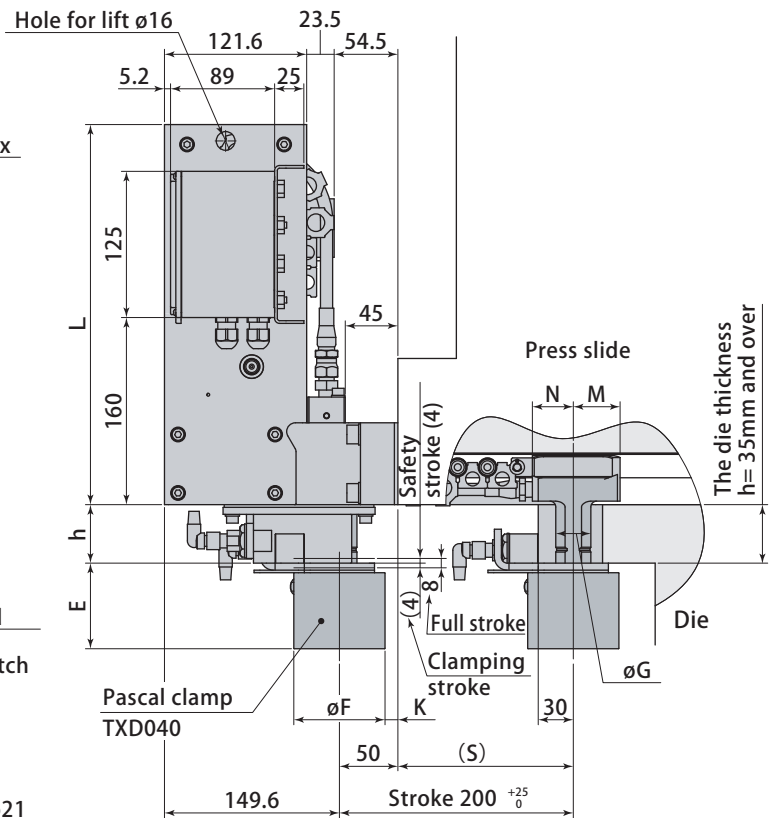
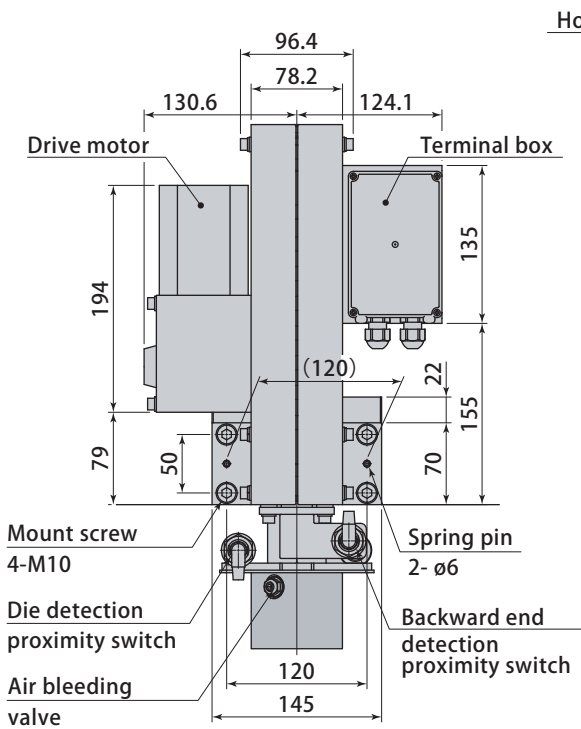
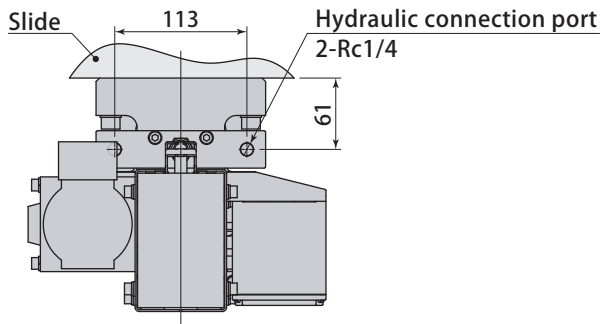

• This diagram indicates the motor, terminal box and prox. Sensor position at **L** position.

Outline dimensions

	mm			
Model	TRX040-0200	TRX040-0300	TRX063-0200	TRX063-0300
E	67.2		73.2	
øF	62		78	
øG	25		30	
K	19		11	
L	325	375	325	375
M	35		40	
N	30		35	
S	150	250	150	250
SS	200	300	200	300
a	28			
Min. b	46			
Min. d	22			
Min. h	35			
Max. h+d	90		100	
Min. j	18			
Max. n	45		55	
Clamp Model	TXD040 (39.2kN)		TXD063 (61.7kN)	

- Specify dimension b, d, j and h.

Drive motor

Manufacturer	Nissei Corporation		
Model	F2SMR-12-60-S15TXH3		
Output	W	15	
Reduction ratio	1:60		
Power supply frequency	VAC	100	
Power supply frequency	Hz	50/60	
Phase	Single phase		
Rated current value	A	0.39/0.35	

- Non-UL or CE approved motor. Consult Pascal for the details.

Proximity switch

Manufacturer	OMRON		
Voltage	V	DC12 ~ 24 (2wire N.O.)	
Model	E2E-X7D1G-M1G		
Cable	XS2F-G422-G80-F		

T-slot dimension and Mounting hole dimension

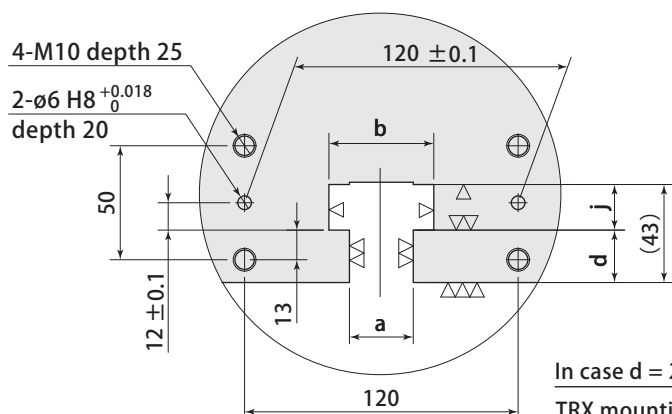

In case d = 23mm
TRX mounting position
moves up or down
according to the d dimension.

U-cut dimension

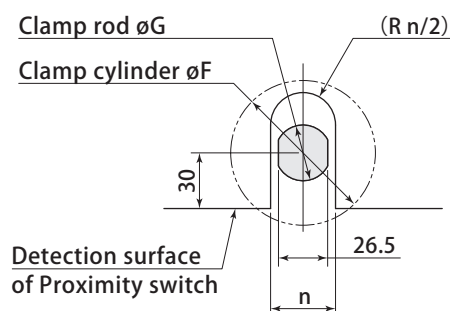

Pascal clamp model TYA

Pascal clamp



T-slotted manual slide type of clamp with lever.



Pascal clamp TYA

Model designation

TYA **063**



Clamping force

Refer to the below specifications for the details.

Specifications

Model		TYA010	TYA020	TYA040	TYA063	TYA100	TYA160	TYA250
Clamping force (at 24.5 MPa)	kN	9.8	19.6	39.2	61.7	98	156	245
Proof pressure	MPa	36.7						
Full stroke	mm	6	7		8			
Clamping stroke	mm	3	4					
Safety stroke	mm	3			4			
Cylinder capacity (at full stroke)	cm ³	2.4	6.3	13.2	22.3	37	61	93
Operating temperature	°C	0 ~ 70 (Standard)						
Approximate weight	kg	1	3	4.5	9	15	25	35

- Working hydraulic pressure : 24.5MPa ● Weight varies according to the dimension of clamp T-leg and die thickness.
- Clamping stroke and safety stroke are the standard, however they are subject to change depending on dimensions of die and T-slot. Contact Pascal for the details.

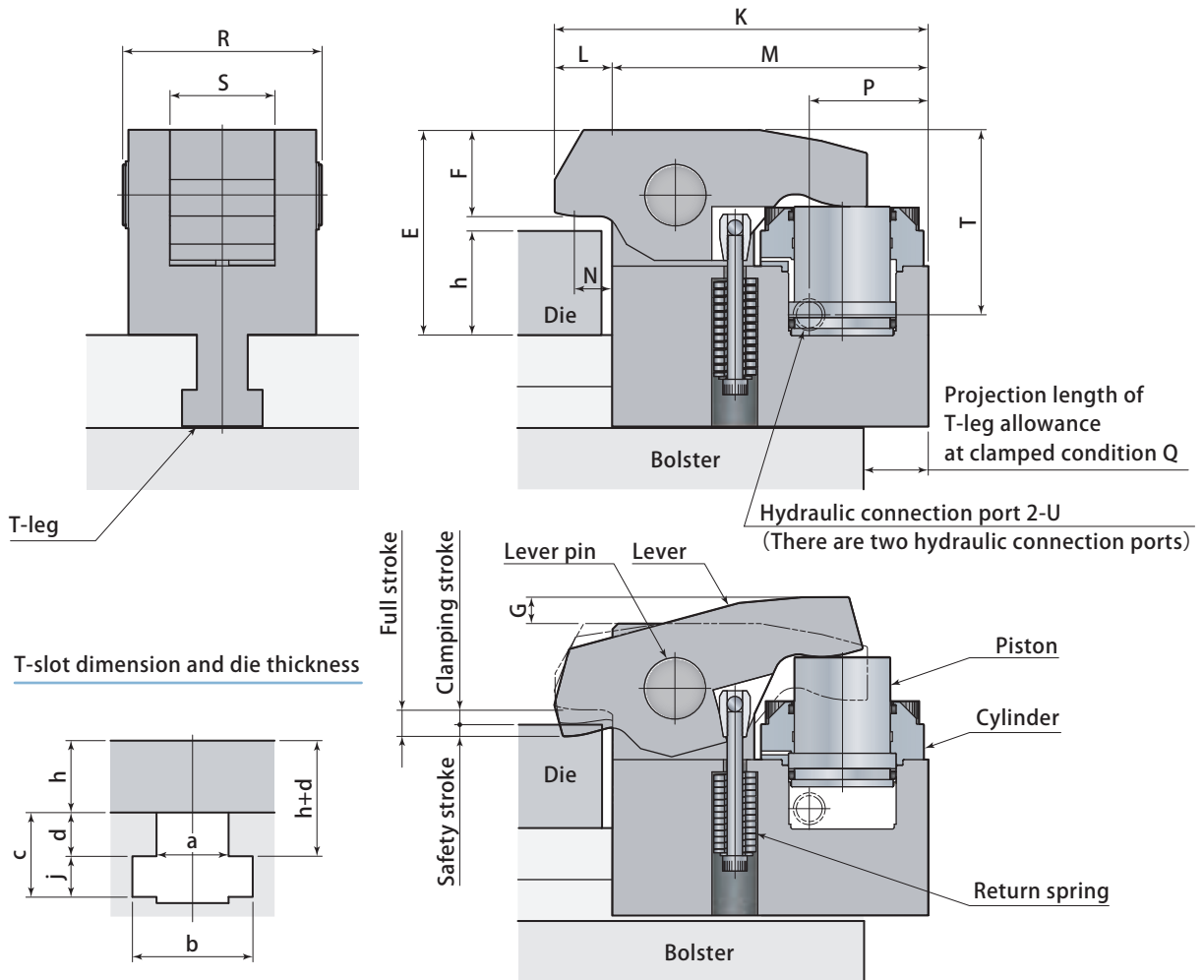

Pascal clamp TYA

Model	TYA010	TYA020	TYA040	TYA063	TYA100	TYA160	TYA250
K	73	101	143	163	195	230	270
L	15	18	23	30	30	30	30
M	58	83	120	133	165	200	240
Clamping point N	10	12.5	16	20	20	20	20
P	31	41	32.5	36	62	80	90
R	46.4	58	73	93	104	125	155
S	20	28	40	50	55	60	72
T	34.5	43	57.5	68.5	97	120	156
Hydraulic connection port U	Rc1/8	Rc1/4					
Max. G	6	10	10	10	11	12	13
Max. Q	18	22	32	36	45	55	69
Min. E	44.5	54	69.5	81.5	107	132	168
Min. a	10	12.5	15	19	23	27	32
Min. j	8	9.5	11.5	15	17	20	23
Tolerance of dimension d	± 0.2						
Max. h	50			60	70	80	100
Min. h	15	22.5	28	28	38	48	68
Tolerance of dimension h	± 0.3						

- Specify T-slot dimensions a, b, d, j and die thickness h. For brand new machine, machine d and h dimensions with the tolerance shown in the above table. For existing machine, specify tolerance of 0.1mm unit on d and h dimensions.
- In case dimension is over Max. h, refer to **page →88** High distance clamp type.
- In case dimension is less than Min. h, refer to **page →90** Low distance clamp type.

● Lever height F varies according to the dimension h.

Model	TYA010	TYA020	TYA040	TYA063	TYA100	TYA160	TYA250
Lever height F	16.5 (25 ≤ h)	17.5 (32.5 ≤ h)	27.5 (38 ≤ h)	29.5 (48 ≤ h)	45 (58 ≤ h)	60 (68 ≤ h)	76 (88 ≤ h)
Inside the parenthesis is range of h	21.5 (20 ≤ h < 25)	22.5 (27.5 ≤ h < 32.5)	32.5 (33 ≤ h < 38)	39.5 (38 ≤ h < 48)	55 (48 ≤ h < 58)	70 (58 ≤ h < 68)	86 (78 ≤ h < 88)
	26.5 (15 ≤ h < 20)	27.5 (22.5 ≤ h < 27.5)	37.5 (28 ≤ h < 33)	49.5 (28 ≤ h < 38)	65 (38 ≤ h < 48)	80 (48 ≤ h < 58)	96 (68 ≤ h < 78)

H High distance clamp type **TYA□-H**

It is applied in case the die thickness is over the standard.

page → 88

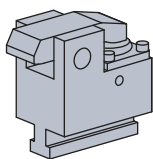

E With die detection proximity switch **TYA□E**

It prevents clamp misplace.

page → 89

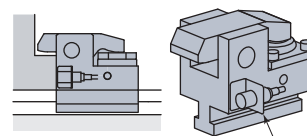

Die detection proximity switch

V Heat proof type **TYA□-V**

It is applied under condition that the die and its surroundings are in high temperature.

Operating temperature : 5 ~ 120°C

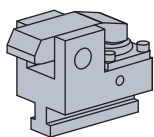

T Low distance clamp type **TYA□-T**

It is applied in case the die thickness is thinner than the standard.

page → 90

Lower type of lever

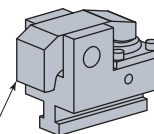

F Bolted type **TYA□-F**

It is applied in case of clamping without T-slot.

pages → 91 ~ 92

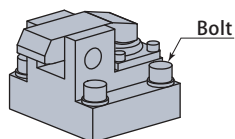

Bolt

W Wide lever type **TYA□-W**

It is applied in case of clamping the die with U-cut.

page → 93

Wide lever

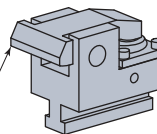

J Rear piping type **TYA□-J**

It is applied in case there are some interferences at clamp side and the side piping connection (standard specification) is not available.

page → 94

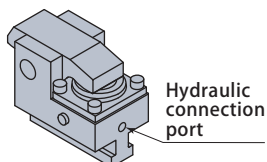

Hydraulic connection port

L Lock type **TYA□-L**

It can fix the clamp installed on the position out of reach, such as the rear side.

page → 95

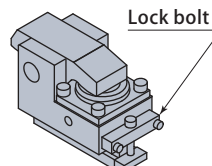

Lock bolt

U With die detection and backward end detection proximity switches **TYA□U**

It prevents misclamping and the damage due to retract back misplace at die change operation.

page → 96

Die detection proximity switch

Backward end detection proximity switch

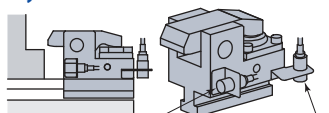

C T-slot type for lateral direction **TYA□-C**

It is applied in case the T-slot is parallel against the die.

page → 97

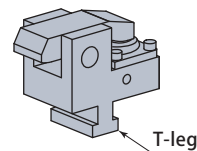

T-leg

G With handle **TYA□-G**

Only for TYA040-250. It does not correspond to TYA010, TYA020.

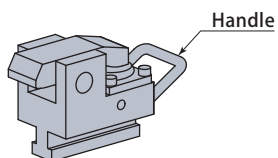

Handle

H High distance clamp type It is applied in case the die thickness is over the standard.

Model designation

TYA **063** - **H**

• Clamping force

TYA010 TYA020 TYA040 TYA063
TYA100 TYA160 TYA250

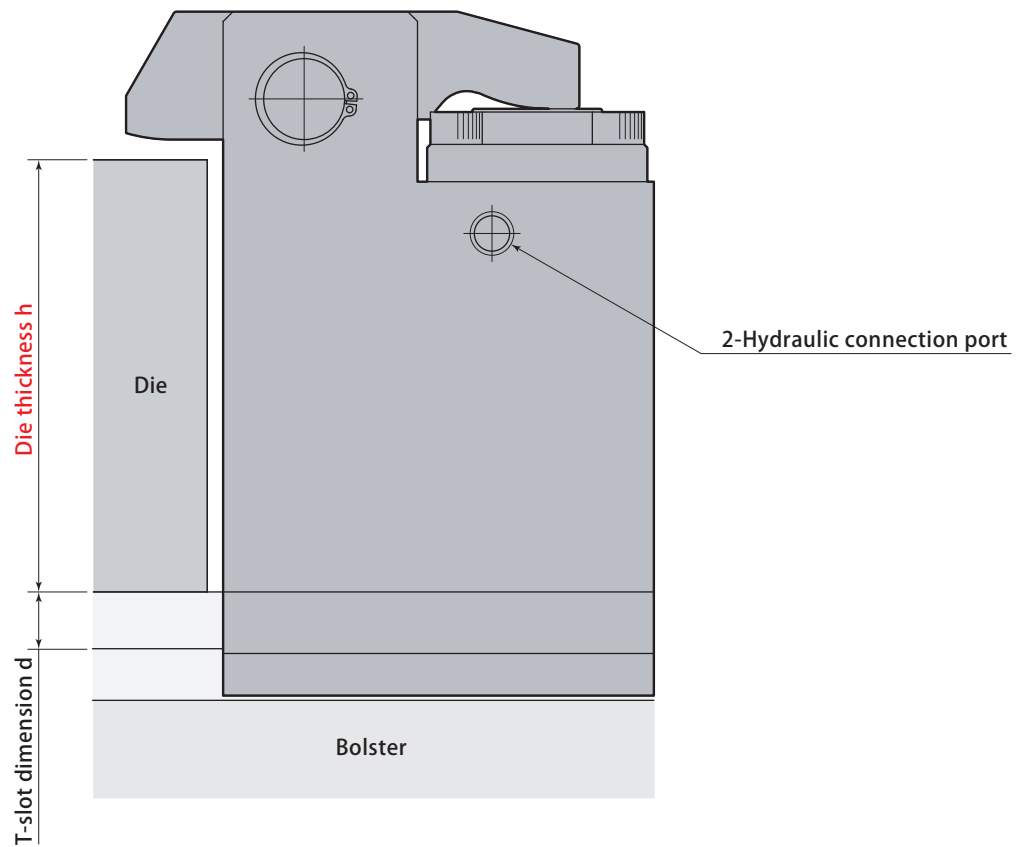

- In case the die thickness h is inside range of the below table, specify the high distance clamp type.
In case the dimension h, d is over the below table, contact Pascal.

Model	TYA010-H	TYA020-H	TYA040-H	TYA063-H	TYA100-H	TYA160-H	TYA250-H
Clamping height h	$50 < h \leq 90$	$50 < h \leq 90$	$50 < h \leq 100$	$60 < h \leq 150$	$70 < h \leq 140$	$80 < h \leq 130$	$100 < h \leq 120$
T-slot dimension d	$d < 30$	$d < 30$	$d < 30$	$d < 40$	$d < 40$	$d < 40$	$d < 40$

mm

E With die detection proximity switch

It prevents clamp misplace.

Model designation

TYA **063** **E** **0** **L**

- 1 Clamping force
- 2 Proximity switch
- 3 Mounting position of die detection proximity switch

- 1 Clamping force TYA010 TYA020 TYA040
TYA063 TYA100 TYA160
TYA250
- 3 Mounting position of die detection proximity switch
L : Left side **R** : Right side

2 Proximity switch

Proximity switch symbol	0	1	2	3
Specifications	DC24V 2-Wire	DC24V 3-Wire(NPN)	AC100V 2-Wire	DC24V 3-Wire(PNP)
Model	E2E-X7D1-N	E2E-X5E1	E2E-X5Y1	E2E-X5F1
Manufacturer name	OMRON			
Insulation vinyl cable length	5m			

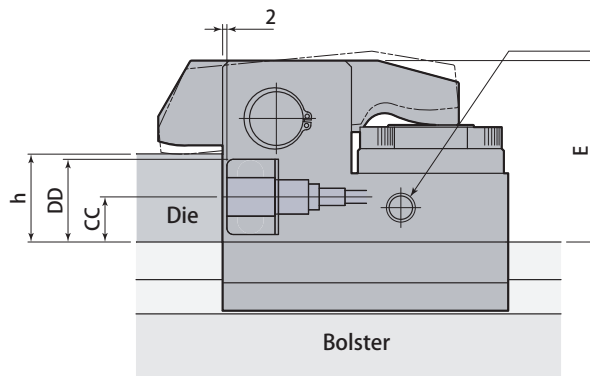
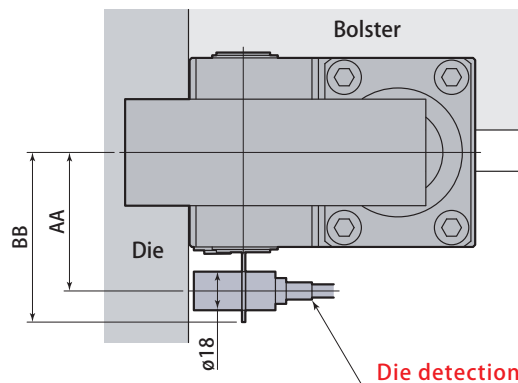

2-Hydraulic connection port
Only 1-oil connection port for TYA010/020 due to sensor mount space.(opposite to the sensor)

● These drawings indicate : mounting position of proximity switch **L**

Model	TYA010E	TYA020E	TYA040E	TYA063E	TYA100E	TYA160E	TYA250E
AA	42	47	54.5	64.5	74	84	98.5
BB	56.5	61.5	69	79	89	99	113.5
CC	15	15	15	21	26	26	32
DD	29.5	29.5	29.5	38.5	51	51	63
Min. E	49.5	54	69.5	81.5	107	132	168
Max. h	50		60	70	80	100	
Min. h	20	22.5	28	28	38	48	68

● Lever height F varies according to the dimension h.

Model	TYA010E	TYA020E	TYA040E	TYA063E	TYA100E	TYA160E	TYA250E
Lever height F	16.5 (30 ≤ h)	17.5 (32.5 ≤ h)	27.5 (38 ≤ h)	29.5 (48 ≤ h)	45 (58 ≤ h)	60 (68 ≤ h)	76 (88 ≤ h)
Inside the parenthesis is range of h	21.5 (25 ≤ h < 30)	22.5 (27.5 ≤ h < 32.5)	32.5 (33 ≤ h < 38)	39.5 (38 ≤ h < 48)	55 (48 ≤ h < 58)	70 (58 ≤ h < 68)	86 (78 ≤ h < 88)
	26.5 (20 ≤ h < 25)	27.5 (22.5 ≤ h < 27.5)	37.5 (28 ≤ h < 33)	49.5 (28 ≤ h < 38)	65 (38 ≤ h < 48)	80 (48 ≤ h < 58)	96 (68 ≤ h < 78)

T **Low distance clamp type** It is applied in case the die thickness is thinner than the standard.

Model designation

TYA **063** - **T**

• Clamping force

TYA010 TYA020 TYA040 TYA063
TYA100 TYA160 TYA250

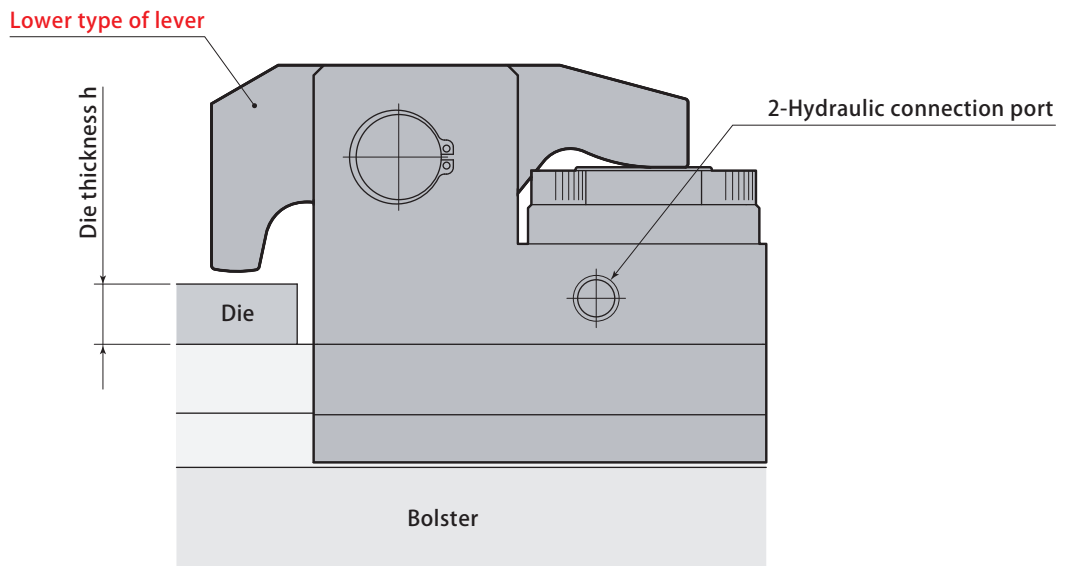

● In case the die thickness h is less than value of the below table, specify the low distance clamp type.

Model	TYA010-T	TYA020-T	TYA040-T	TYA063-T	TYA100-T	TYA160-T	TYA250-T
Die thickness h	$h < 15$	$h < 22.5$	$h < 28$	$h < 28$	$h < 38$	$h < 48$	$h < 68$

mm

● Refer to another document for the applicable h dimension for TYA□ET, YA□-FT, TYA□-JT.

F Bolt type

It is applied in case of clamping without T-slot.

Model designation

TYA 063 - F

• Clamping force

- TYA010 TYA020 TYA040 TYA063
- TYA100 TYA160 TYA250

TYA020-F TYA040-F TYA063-F TYA100-F TYA160-F TYA250-F

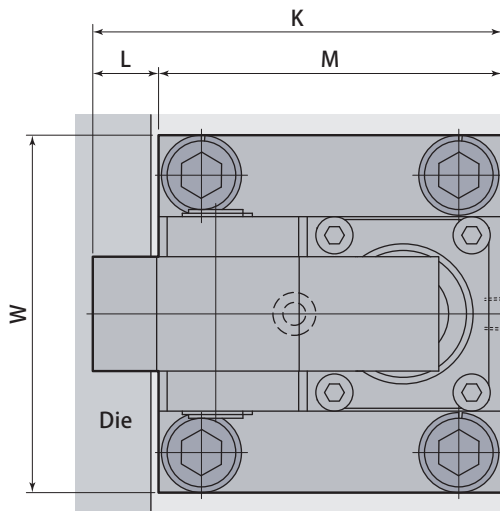

Mounting details

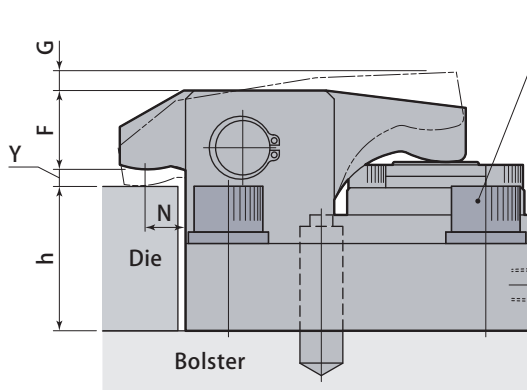
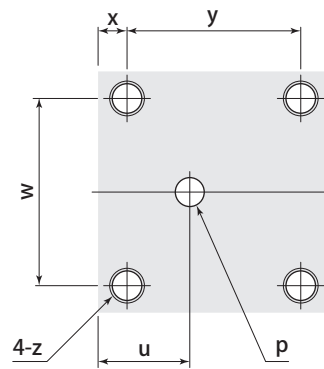

Bolt
(included)

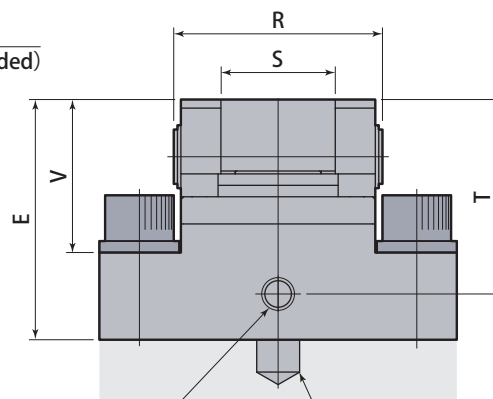

Hydraulic connection port
Rc1/4

Mounting hole
for escape pit of spring

TYA010-F

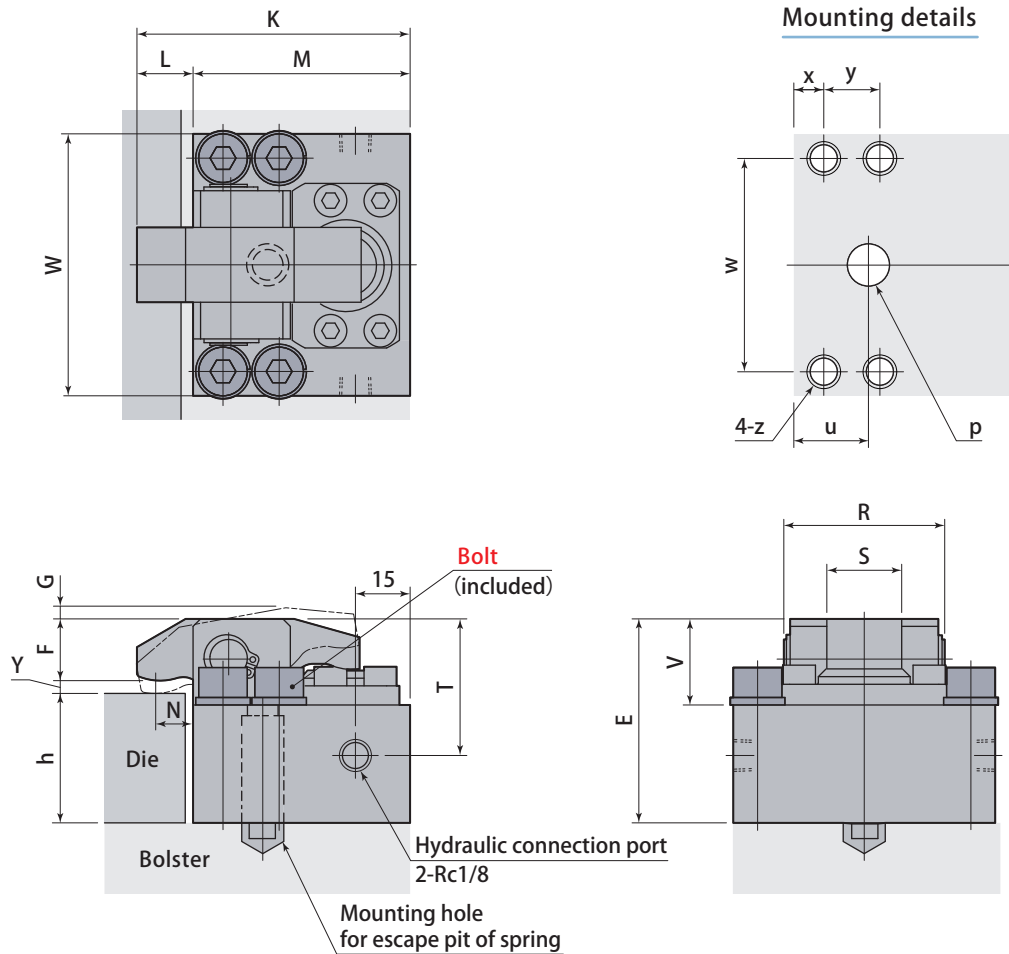

Pascal clamp TYA
Special type

Model	TYA010-F	TYA020-F	TYA040-F	TYA063-F	TYA100-F	TYA160-F	TYA250-F
K	73	101	143	163	195	230	270
L	15	18	23	30	30	30	30
M	58	83	120	133	165	200	240
Clamping point N	10	12.5	16	20	20	20	20
R	46.4	58	73	93	104	125	155
S	20	28	40	50	55	60	72
T	36.5	54	68	79	97	120	156
Max. G	6	10	10	10	11	12	13
Min. E	48.5	66	80	91	115	142	177
V	23	31	53.5	52.5	71	89	113
W	70	98	125	148	180	214	260
Y	3	4	4	4	4	4	4
Max. h		50		60	70	80	100
Min. h	19	34.5	38.5	37.5	46	58	77

mm

Model	TYA010-F	TYA020-F	TYA040-F	TYA063-F	TYA100-F	TYA160-F	TYA250-F
x	8	15	15	15	20	25	27.5
y	15	53	90	40	50	60	55
u	19.5	30.5	47.5	53	65.7	74.5	90.5
w	57	77	97	120	142	168	205
z	M8 depth 20	M12 depth 24	M16 depth 30	M16 depth 30	M20 depth 40	M24 depth 48	M30 depth 56
p	ø11 depth 59.5-E	ø14 depth 79.5-E	ø18 depth 102-E	ø22 depth 117-E	ø26 depth 138-E	ø30 depth 166-E	ø30 depth 197-E

mm

● Lever height F varies according to the dimension h.

Model	TYA010-F	TYA020-F	TYA040-F	TYA063-F	TYA100-F	TYA160-F	TYA250-F
Lever height F	16.5 (29 ≤ h)	17.5 (44.5 ≤ h)	27.5 (48.5 ≤ h)	29.5 (57.5 ≤ h)	45 (66 ≤ h)	60 (78 ≤ h)	76 (97 ≤ h)
Inside the parenthesis is range of h	21.5 (24 ≤ h < 29)	22.5 (39.5 ≤ h < 44.5)	32.5 (43.5 ≤ h < 48.5)	39.5 (47.5 ≤ h < 57.5)	55 (56 ≤ h < 66)	70 (68 ≤ h < 78)	86 (87 ≤ h < 97)
	26.5 (19 ≤ h < 24)	27.5 (34.5 ≤ h < 39.5)	37.5 (38.5 ≤ h < 43.5)	49.5 (37.5 ≤ h < 47.5)	65 (46 ≤ h < 56)	80 (58 ≤ h < 68)	96 (77 ≤ h < 87)

mm

W **Wide lever type** It is applied in case of clamping the die with U-cut.

Model designation

TYA **063** - **W**

••• Clamping force

- TYA010 TYA020 TYA040 TYA063
- TYA100 TYA160 TYA250

Pascal clamp TYA
Special type

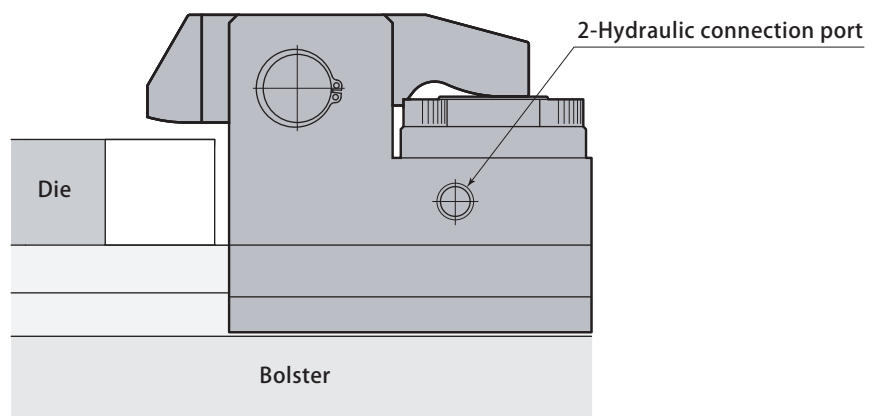
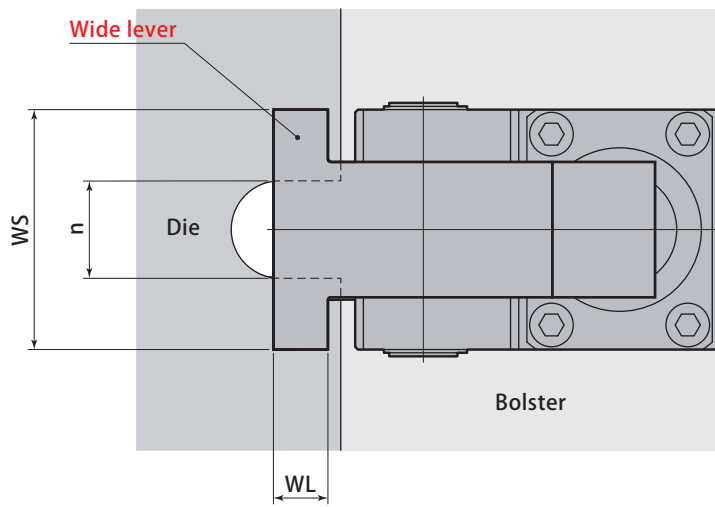

Model	TYA010-W	TYA020-W	TYA040-W	TYA063-W	TYA100-W	TYA160-W	TYA250-W
WS	43	62	72	88	88	100	110
WL	10	13	15	20	20	20	20
Max. n	22	32	32	36	32	40	40

mm

J Rear piping type

It is applied in case there are some interferences at clamp side and the side piping connection(standard specification) is not available.

Model designation

TYA **063** - **J**

• Clamping force

- TYA010 TYA020 TYA040 TYA063
- TYA100 TYA160 TYA250

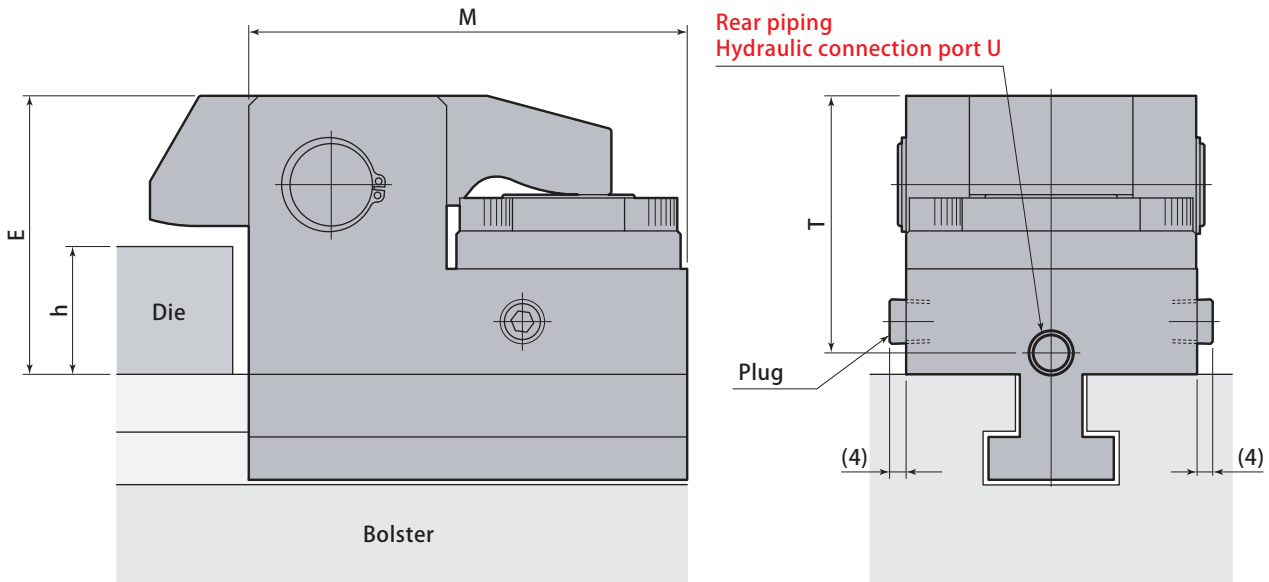

Model	TYA010-J	TYA020-J	TYA040-J	TYA063-J	TYA100-J	TYA160-J	TYA250-J
M	63	83	120	133	165	200	240
T	40.5	54	68	79	97	120	156
U	Rc1/8	Rc1/4	Rc1/4	Rc1/4	Rc1/4	Rc1/4	Rc1/4
Min. E	50	65	79	90	107	132	168
Max.h	50			60	70	80	100
Min. h	20.5	33.5	37.5	36.5	38	48	68

● Lever height F varies according to the dimension h.

Model	TYA010-J	TYA020-J	TYA040-J	TYA063-J	TYA100-J	TYA160-J	TYA250-J
Lever height F	16.5 (30.5 ≤ h)	17.5 (43.5 ≤ h)	27.5 (47.5 ≤ h)	29.5 (56.5 ≤ h)	45 (58 ≤ h)	60 (68 ≤ h)	76 (88 ≤ h)
Inside the parenthesis is range of h	21.5 (25.5 ≤ h < 30.5)	22.5 (38.5 ≤ h < 43.5)	32.5 (42.5 ≤ h < 47.5)	39.5 (46.5 ≤ h < 56.5)	55 (48 ≤ h < 58)	70 (58 ≤ h < 68)	86 (78 ≤ h < 88)
	26.5 (20.5 ≤ h < 25.5)	27.5 (33.5 ≤ h < 38.5)	37.5 (37.5 ≤ h < 42.5)	49.5 (36.5 ≤ h < 46.5)	65 (38 ≤ h < 48)	80 (48 ≤ h < 58)	96 (68 ≤ h < 78)

L Lock type

It can fix the clamp installed on the position out of reach, such as the rear side.

Model designation

TYA **063** - **L**

• Clamping force

- TYA010 TYA020 TYA040 TYA063
- TYA100 TYA160 TYA250

TYA020-L TYA040-L TYA063-L TYA100-L TYA160-L TYA250-L

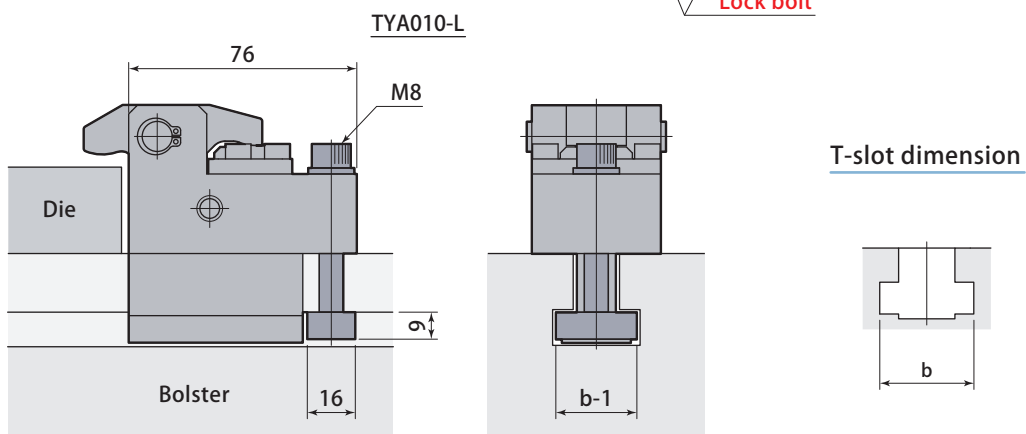
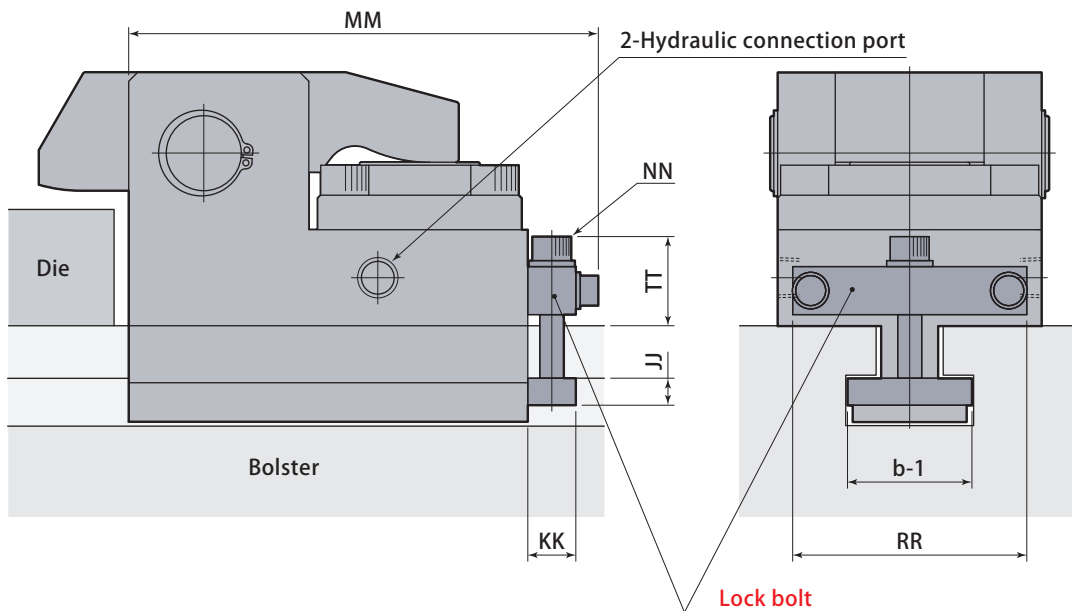

Model	TYA020-L	TYA040-L	TYA063-L	TYA100-L	TYA160-L	TYA250-L
MM	106.5	143.5	156.5	188.5	223.5	280
NN	M8	M8	M8	M8	M8	M16
KK	16	16	16	16	16	25
JJ	9	9	9	9	9	16
RR	53	64	78	88	108	100
TT	29	29	29	29	29	52

mm

U With die detection and backward end detection proximity switch

It prevents misclamping and the damage due to retract back misplace at die change operation.

Model designation

TYA **063** **U** **0** **L** **R**

- 1 Clamping force
- 2 Proximity switch
- 3 Mounting position of die detection proximity switch
- 4 Mounting position of backward end detection proximity switch

- 1 Clamping force
TYA040 TYA063 TYA100
TYA160 TYA250
- 3 Mounting position of die detection proximity switch
L : Left side **R** : Right side
- 4 Mounting position of backward end detection proximity switch
L : Left side **R** : Right side

2 Proximity switch

Proximity switch symbol		0(Std.)	1	2	3
Specifications		DC24V 2 Wire	DC24V 3 Wire(NPN)	AC100V 2 Wire	DC24V 3 Wire (PNP)
Model	Die detection	E2E-X7D1-N	E2E-X5E1	E2E-X5Y1	E2E-X5F1
	Backward end detection	E2E-X7D2-N	E2E-X5E2	E2E-X5Y2	E2E-X5F2
Manufacturer name		OMRON			
Insulation vinyl cable length		5m			

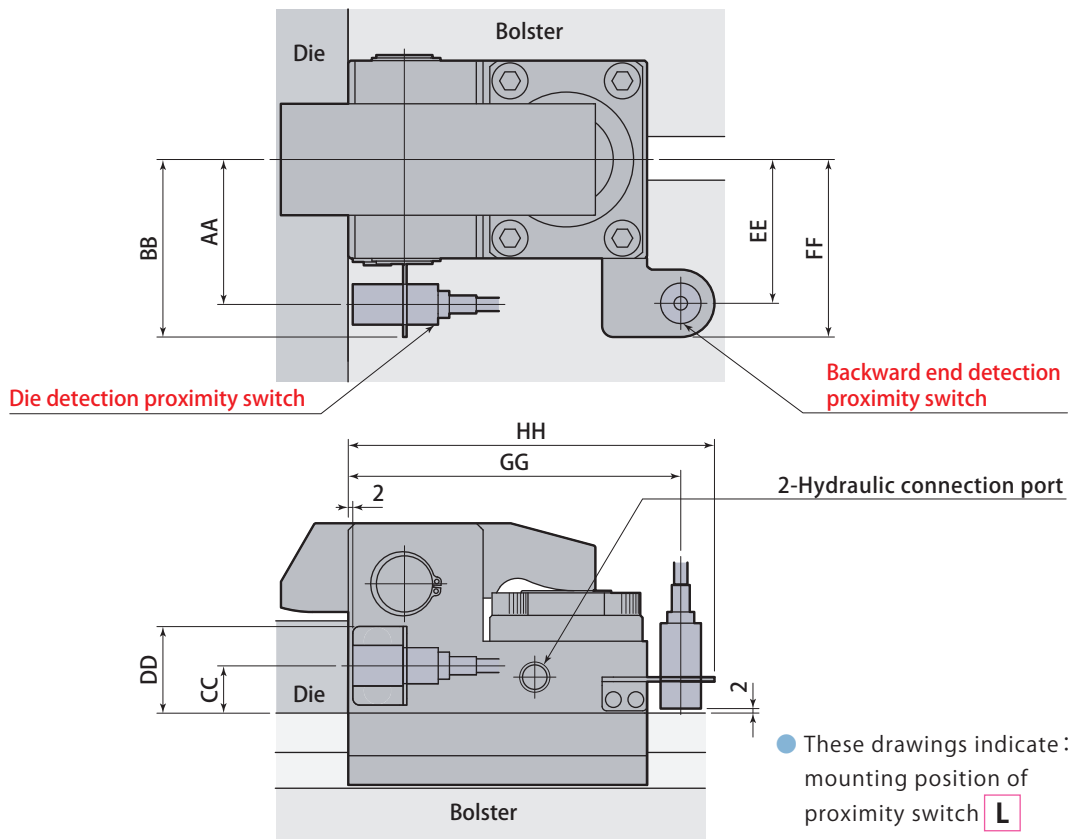

mm

Model	TYA040U	TYA063U	TYA100U	TYA160U	TYA250U
AA	54.5	64.5	74	84	98.5
BB	69	79	89	99	113.5
CC	15	21	26	26	32
DD	29.5	38.5	51	51	63
EE	54	64	69	79	93.5
FF	69	79	84	94	108.5
GG	135	148	180	215	255
HH	150	163	195	230	270

C T-slot type for lateral direction

It is applied in case the T-slot is parallel against the die.

Model designation

TYA 063 - C

• Clamping force

TYA010 TYA020 TYA040 TYA063

Pascal clamp TYA
Special type

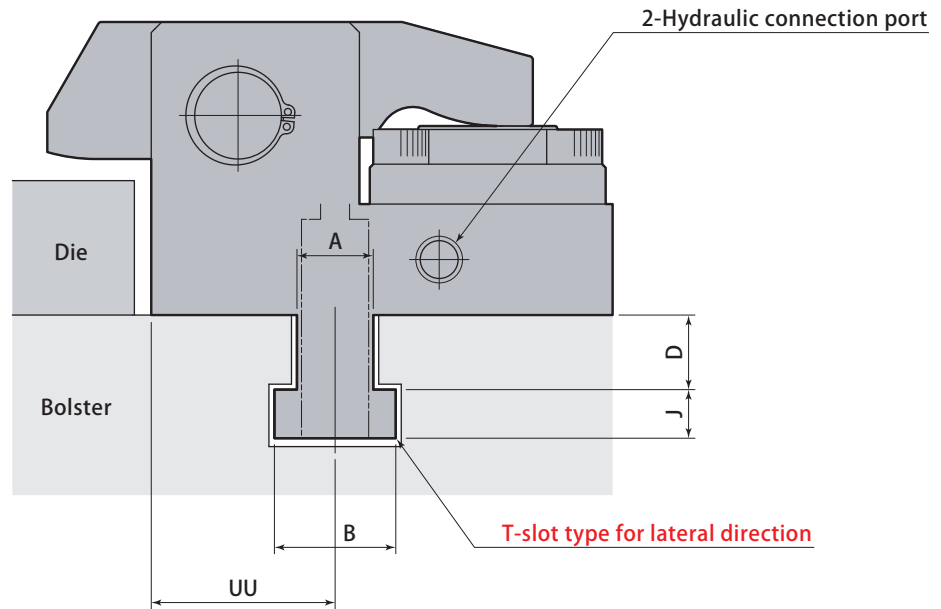

- T-leg dimensions A, B, D, J are determined based on T-slot dimensions.
- The dimension UU is unchangeable due to the existence of spring.

Model	TYA010-C	TYA020-C	TYA040-C	TYA063-C
UU	19.5	30.3	47.5	53.0

mm

For TYA temporary hanging

Upper and lower type of clamp hook

Model designation

FYA 01 - 18

1 Hook size

2 W dimension (mm)

1 Hook size

FYA01 FYA02 FYA03 FYA04

2 W dimension (mm)

Refer to the below table.

Installation example of the upper type of clamp

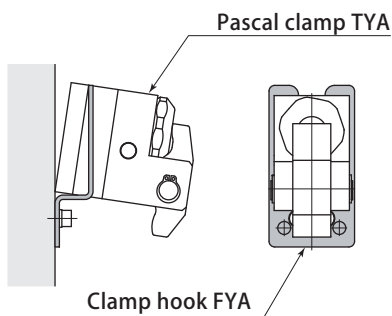

Installation example of the lower type of clamp

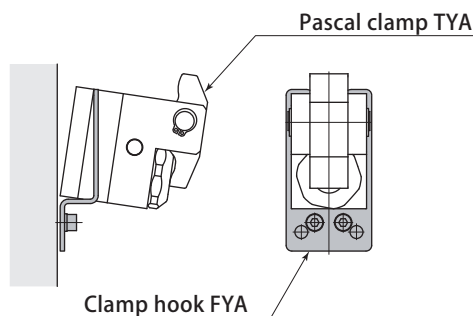

- The shape of the upper and lower type of hook is the same.
- Do not operate the machine with clamp hung on the clamp hook.
- Contact Pascal when the holder is used for model TYA□-H.

- The mount screw is not furnished. If necessary, order the mount screw type sold separately.

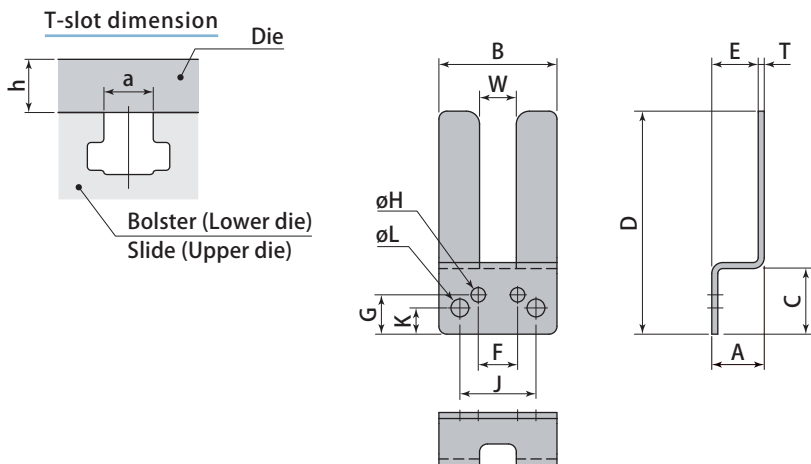

øH Mount screw

Hook type	Reference specification	Mount screw type (option)
FYA01	2-M5 length 12	FXA-A05
FYA02	2-M6 length 14	FXA-A06
FYA03	2-M8 length 16	FXA-A08
FYA04	2-M10 length 20	FXA-A10

øL Mount screw

Hook type	Reference specification	Mount screw type (option)
FYA01	2-M6 length 14	FXA-A06
FYA02	2-M8 length 16	FXA-A08
FYA03	2-M10 length 20	FXA-A10
FYA04	2-M12 length 20	FXA-A12

Clamp model	TYA010				TYA020					TYA040				TYA063			TYA100		
	Less than 14	15~18	19~22		Less than 14	15~18	19~22	23~28	29~34	Less than 18	19~22	23~28	29~34	Less than 22	23~28	29~34	Less than 28	29~34	35~40
T-slot a mm	FYA01 -14	FYA01 -18	FYA01 -22		FYA02 -14	FYA02 -18	FYA02 -22	FYA02 -28	FYA02 -34	FYA02 -18	FYA02 -22	FYA02 -28	FYA02 -34	FYA03 -22	FYA03 -28	FYA03 -34	FYA04 -28	FYA04 -34	FYA04 -40
W mm	14	18	22		14	18	22	28	34	18	22	28	34	22	28	34	28	34	40
A mm	20				27					27				29			34		
B mm	45				75					75				75			100		
C mm	25				25					25				28.7			35.5		
D mm	85				105					105				110			170		
E mm	17.7				23.8					23.8				24.5			29.5		
T mm	2.3				3.2					3.2				4.5			4.5		
F mm	15				26					26				22			27		
G mm	15				10					10				15			17		
øH mm	5.5				6.8					6.8				9			11		
J mm	29				49					49				49			60		
K mm	10				10					10				15			17		
øL mm	6.8				9					9				11			14		
Max. h mm	100				100					80				80			70		
Weight kg	0.1				0.2					0.2				0.3			0.6		

Pascal clamp TYA Clamp hook

Pascal clamp model **TYC**

Pascal clamp automatic slidable type

Automatic slidable TYC



Automatic slidable clamp with air cylinder. It enables to shorten the die exchange time.

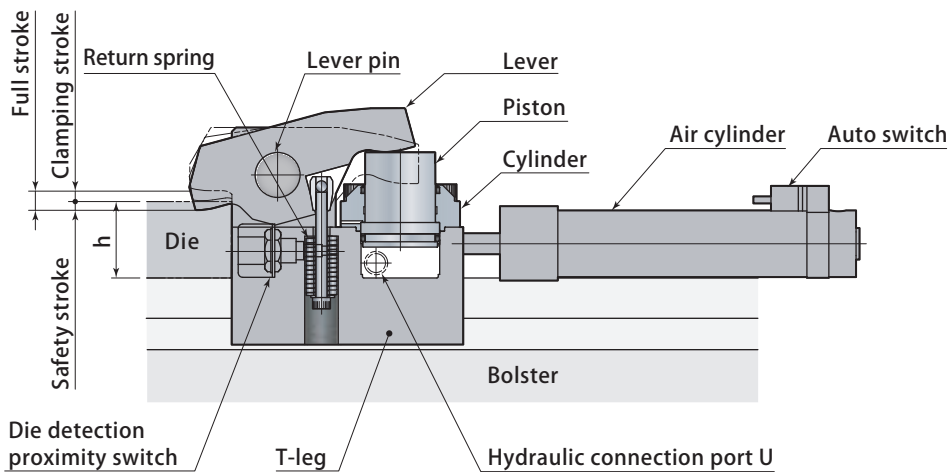

T-slot dimension & die thickness

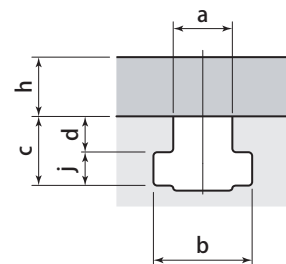

Specifications

Model		TYC020	TYC040	TYC063	TYC100	TYC160	TYC250	
Clamping force (at 24.5 MPa)	kN	19.6	39.2	61.7	98	156	245	
Proof pressure	MPa	36.7						
Full stroke	mm	7			8			
Clamping stroke	mm	4						
Safety stroke	mm	3			4			
Cylinder capacity at full stroke	cm ³	6.3	13.2	22.3	37	61	93	
Operating temperature	°C	0 ~ 70 (Standard)						
Approximate weight	kg	3.5	5	10	16	26	38	
Max. a	mm	12.5	15	19	23	27	32	
Min. j	mm	9.5	11.5	15	17	20	23	
Tolerance of dimension d	mm	± 0.2						
Max. h	mm	50	50	60	70	80	100	
Min. h	mm	33.5	28	28	38	48	68	
Tolerance of dimension h	mm	± 0.3						

- Working hydraulic pressure : 24.5MPa ● Weight varies according to the dimension of clamp T-leg and die thickness as well as sliding stroke.
- Specify T-slot dimensions a, b, d, j and die thickness h. For brand new machine, machine d and h dimensions with the tolerance shown in the above table. For existing machine, specify tolerance of 0.1mm unit on d and h dimensions.
- In case dimension is over Max. h, refer to **page→109** High distance clamp type.
- In case dimension is less than Min. h, refer to **page→110** Low distance clamp type. ● Stop the press during the clamp wait.

Model designation

TYC **063** R **0** L - **075**

- 1 Clamping force
- 2 Proximity switch
- 3 Mounting position of die detection proximity switch
- 4 Sliding stroke (mm) *Indicated in 3 digits

- 1 Clamping force
 TYC020 : 19.6kN
 TYC040 : 39.2kN
 TYC063 : 61.7kN
 TYC100 : 98kN
 TYC160 : 156kN
 TYC250 : 245kN

2 Proximity switch

Proximity switch symbol	0	1	2	3
Specifications	DC24V 2Wire	DC24V 3Wire(NPN)	AC100V 2Wire	DC24V 3Wire (PNP)
Model	E2E-X7D1-N	E2E-X5E1	E2E-X5Y1	E2E-X5F1
Manufacturer name	OMRON			
Insulation vinyl cable length	5m			

3 Mounting position of die detection proximity switch

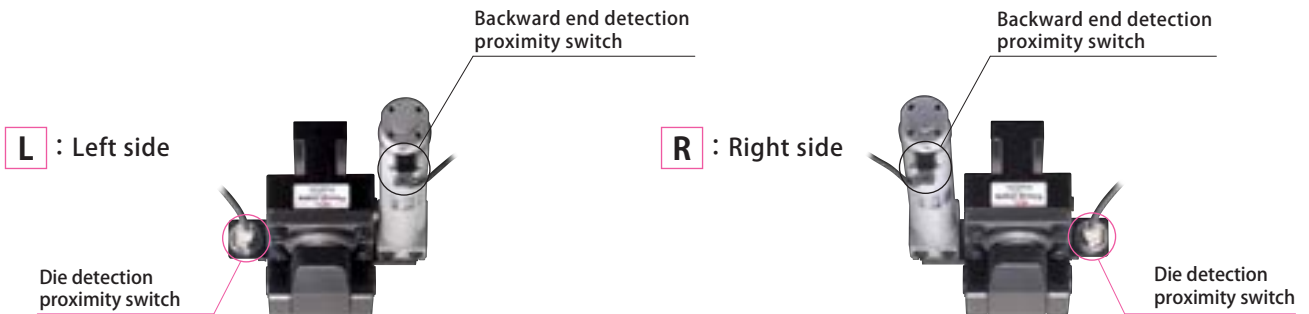

4 Slide stroke

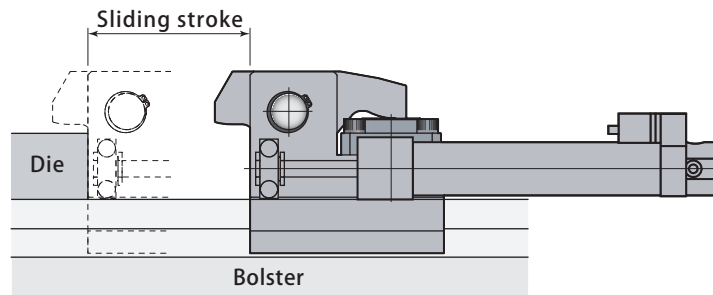

Model	TYC020R	TYC040R	TYC063R	TYC100R	TYC160R	TYC250R
Sliding stroke *	mm	25, 50, 75, 100, 125, 150	50, 75, 100, 125, 150, 200	50, 75, 100, 125, 150, 200, 250, 300		
Air cylinder driven pressure	MPa	0.39 ~ 0.54				
Slide velocity	mm/s	30 ~ 100 (to be adjusted by a flow control valve)				
Air cylinder model	CDG1RN20-□-B54LS	CDG1RN32-□-B54LS	CDG1RN40-□-B54LS	CDG1RN50-□-B54LS		
Air cylinder manufacturer	SMC					

● Refer to **page →106** for the details of sliding stroke.
 * Contact Pascal for the sliding stroke which is not mentioned above.

Unclamp

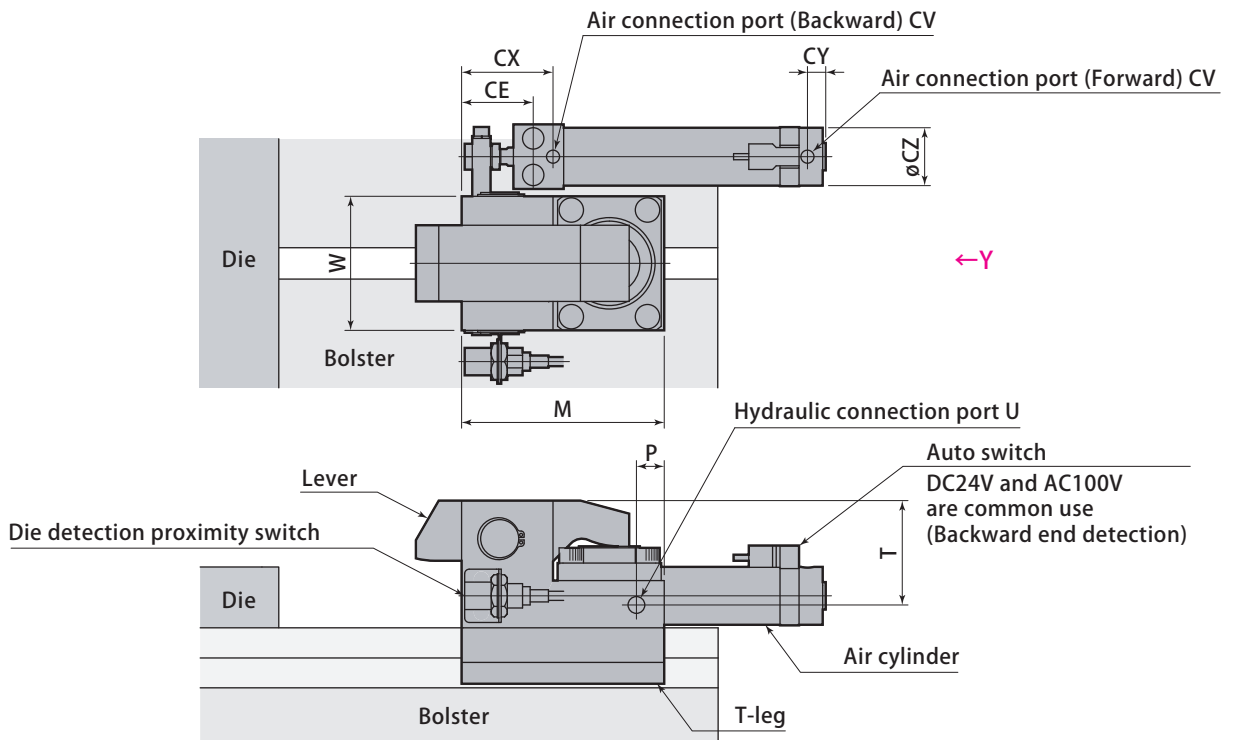

Clamp

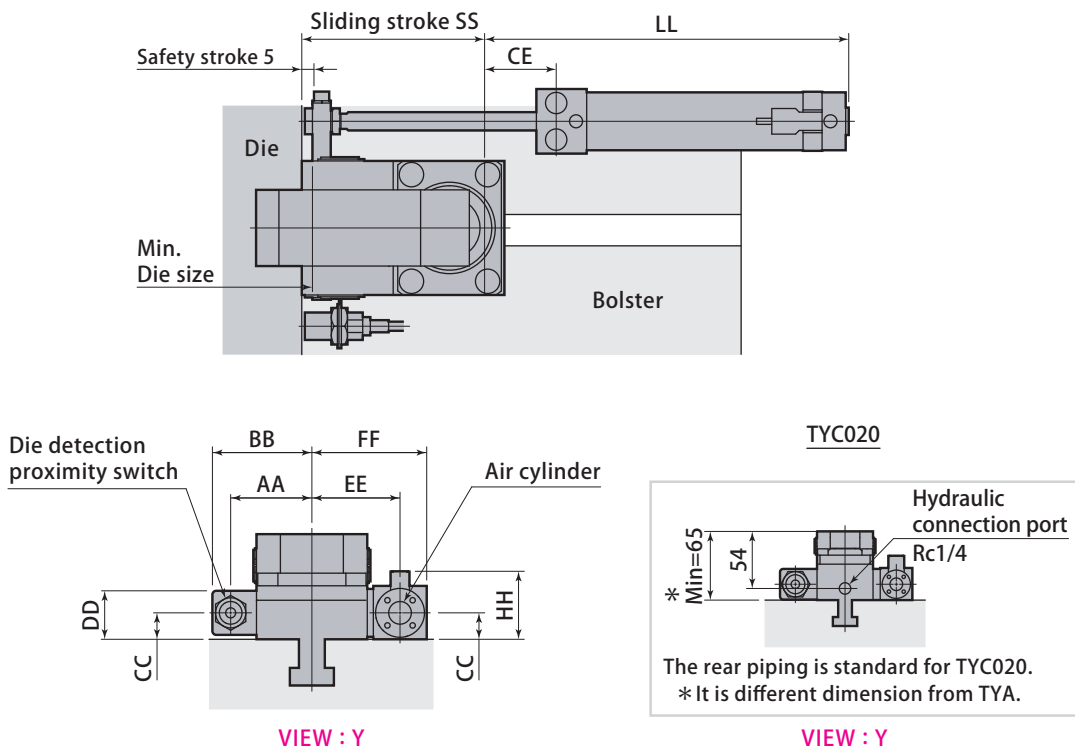

● These drawings indicate : mounting position of proximity switch **R**

External dimension

Model	TYC020	TYC040	TYC063	TYC100	TYC160	TYC250
Air connection port CV	Rc1/8	Rc1/8	Rc1/8	Rc1/8	Rc1/8	Rc1/4
CX	51.5	51.5	60	71	71	87
CY	12	12	12	12	12	14
øCZ	26	26	38	47	47	58
W	53	68	88	98	118	147
M	83	120	133	165	200	240
CE	42.5	42.5	47	57	57	71
P	—	32.5	36	62	80	90
Hydraulic connection port U	—	Rc1/4	Rc1/4	Rc1/4	Rc1/4	Rc1/4
T	—	57.5	68.5	97	120	156
BB	61.5	69	79	89	99	113.5
FF	64.6	72.1	89.5	109	119	153
AA	47	54.5	64.5	74	84	98.5
EE	48.5	56	70	81	91	116
DD	29.5	29.5	38.5	51	51	63
CC	15	15	21	26	26	32
HH	42	42	54	63	63	74
Mount screw	2-M5 length 35	2-M5 length 35	2-M8 length 45	2-M10 length 55	2-M10 length 55	2-M12 length 70
Quadrate spring washer	2-M5	2-M5	2-M8	2-M10	2-M10	2-M12
Auto switch model	D-B54L					
Insulation vinyl cable with auto switch	3m					

Sliding stroke 25 50 75 100 125 150 200 250 300 mm

Sliding stroke SS	TYC020	TYC040	TYC063	TYC100	TYC160	TYC250
	Overall length LL					
25	133.5	133.5	—	—	—	—
50	158.5	158.5	169	187	187	214
75	183.5	183.5	194	212	212	239
100	208.5	208.5	219	237	237	264
125	233.5	233.5	244	262	262	289
150	258.5	258.5	269	287	287	314
200	—	—	319	337	337	364
250	—	—	—	387	387	414
300	—	—	—	437	437	464

● Lever height F varies according to the dimension h.

Model	TYC020	TYC040	TYC063	TYC100	TYC160	TYC250
Lever height F	17.5 (43.5 ≤ h)	27.5 (38 ≤ h)	29.5 (48 ≤ h)	45 (58 ≤ h)	60 (68 ≤ h)	76 (88 ≤ h)
Inside the parenthesis is range of h	22.5 (38.5 ≤ h < 43.5)	32.5 (33 ≤ h < 38)	39.5 (38 ≤ h < 48)	55 (48 ≤ h < 58)	70 (58 ≤ h < 68)	86 (78 ≤ h < 88)
	27.5 (33.5 ≤ h < 38.5)	37.5 (28 ≤ h < 33)	49.5 (28 ≤ h < 38)	65 (38 ≤ h < 48)	80 (48 ≤ h < 58)	96 (68 ≤ h < 78)

Mounting details

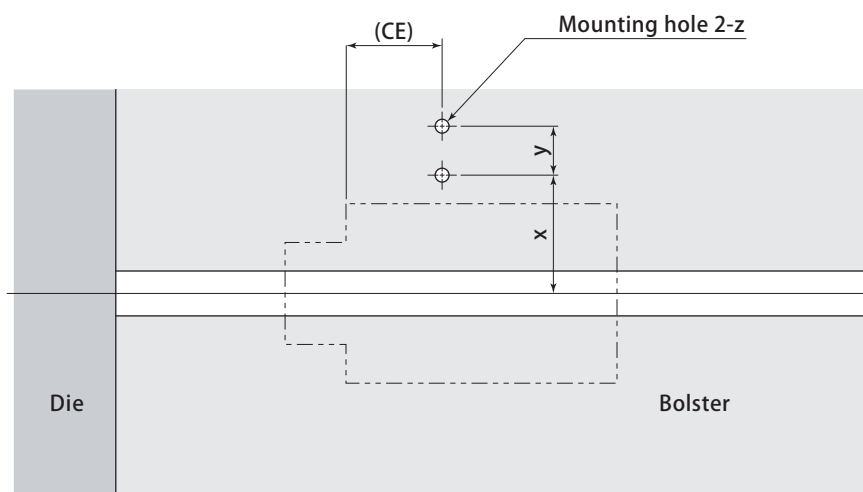
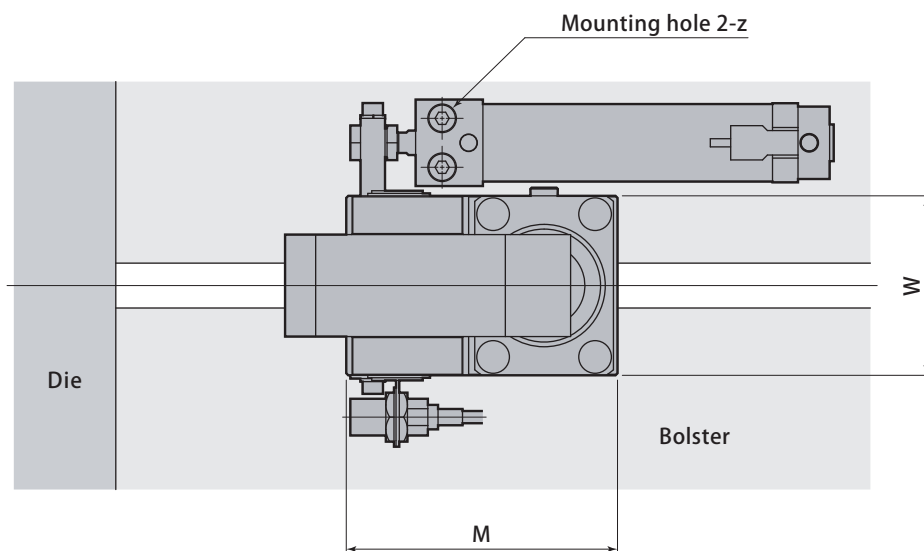

● These drawings indicate : mounting position of proximity switch **R**

mm

Model	TYC020	TYC040	TYC063	TYC100	TYC160	TYC250
CE	42.5	42.5	47	57	57	71
M	83	120	133	165	200	240
W	53	68	88	98	118	147
x	39.5	47	58	65	75	95.5
y	18	18	24	32	32	41
z	M5 depth12	M5 depth12	M8 depth12	M10 depth16	M10 depth16	M12 depth20

H High distance clamp type TYC□-H

It is applied in case the die thickness is over the standard.

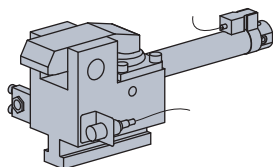

page → 109

T Low distance clamp type TYC□-T

It is applied in case the die thickness is thinner than the standard.

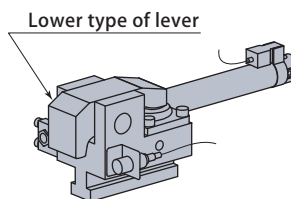

page → 110

V Heat proof type TYC□-V

It is applied under condition that the die and its surroundings are in high temperature.

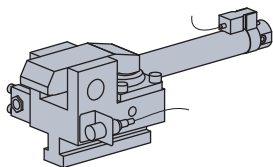

Operating temperature: 5 ~ 120°C

J Rear piping type TYC□-J

It is applied in case there are some interferences at clamp side and the side piping connection (standard specification) is not available.

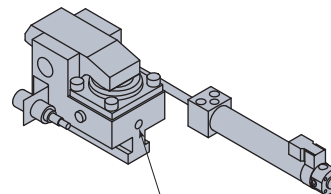

page → 111

W Wide lever type TYC□-W

It is applied in case of clamping the die with U-cut.

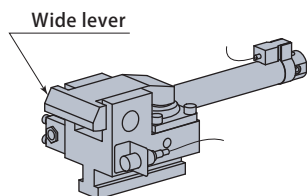

page → 112

S1 S2 Material strength TYC□-S1, TYC□-S2

It is applied in case the T-slot dimension is under the standard and the strength is insufficient.

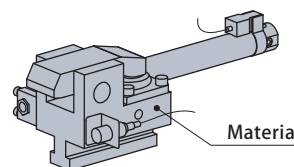

TYC□-S1: S45C
TYC□-S2: SCM435 Quenching and high-temperature tempering

H High distance clamp type It is applied in case the die thickness is over the standard.

Model designation

TYC 063 R 0 L - 075 - H

- 1 Clamping force
- 2 Proximity switch
- 3 Mounting position of die detection proximity switch
- 4 Sliding stroke (mm)
* Indicated in 3 digits

1 2 3 4 Refer to page → 104

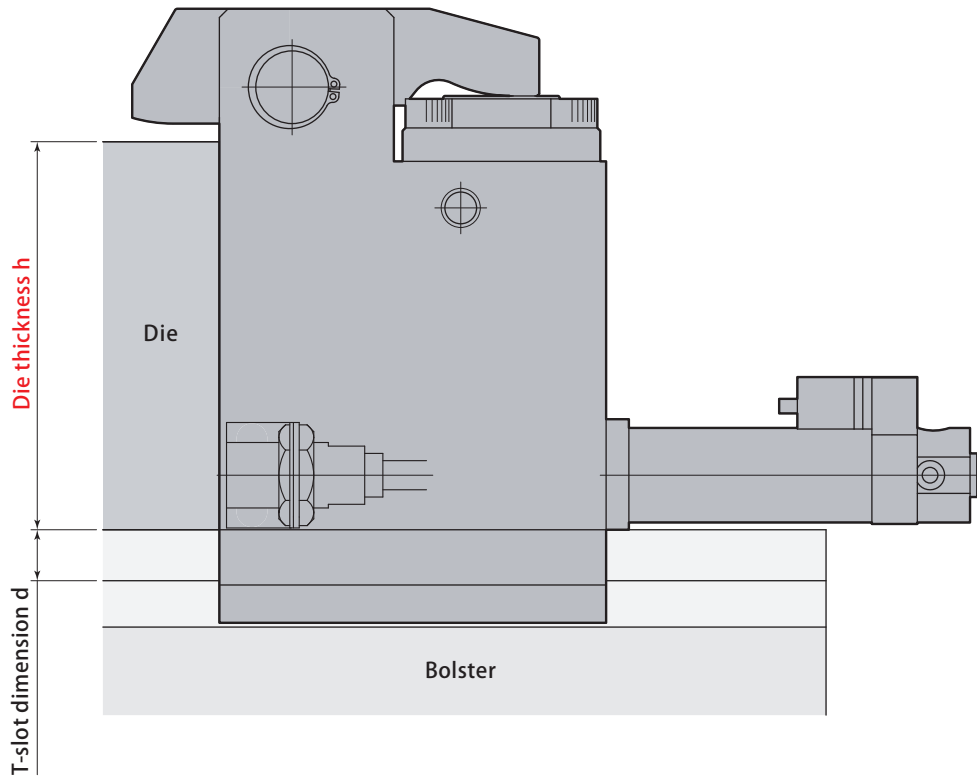

- In case the die thickness h is inside range of the below table, specify the high distance clamp type. In case the dimension h is over the below table, contact Pascal.

mm

Model	TYC020R-H	TYC040R-H	TYC063R-H	TYC100R-H	TYC160R-H	TYC250R-H
Die thickness h	50 < h ≤ 100	50 < h ≤ 100	60 < h ≤ 150	70 < h ≤ 140	80 < h ≤ 130	100 < h ≤ 120
T-slot dimension d	d < 30	d < 30	d < 30	d < 40	d < 40	d < 40

T **Low distance clamp type** It is applied in case the die thickness is thinner than the standard.

Model designation

TYC 063 R 0 L - 075 - T

- 1 Clamping force
- 2 Proximity switch
- 3 Mounting position of die detection proximity switch
- 4 Sliding stroke (mm)
* Indicated in 3 digits

1 2 3 4 Refer to page → 104

Lower type of lever

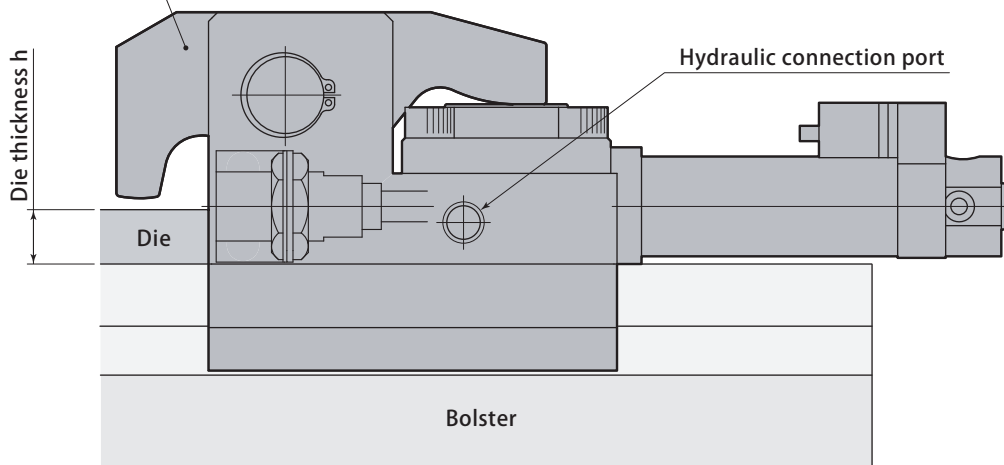

● In case the die thickness h is less than value of the below table, specify the Low distance clamp type.

Model	TYC020R-T	TYC040R-T	TYC063R-T	TYC100R-T	TYC160R-T	TYC250R-T
Die thickness h	h < 33.5	h < 28	h < 28	h < 38	h < 48	h < 68

mm

J **Rear piping type** It is applied in case there are some interferences at clamp side and the side piping connection (standard specification) is not available.

Model designation

TYC 063 R 0 L - 075 - J

- 1 Clamping force ●
- 2 Proximity switch ●
- 3 Mounting position ● of die detection proximity switch
- 4 Sliding stroke (mm) ●
* Indicated in 3 digits

1 2 3 4 Refer to page → 104

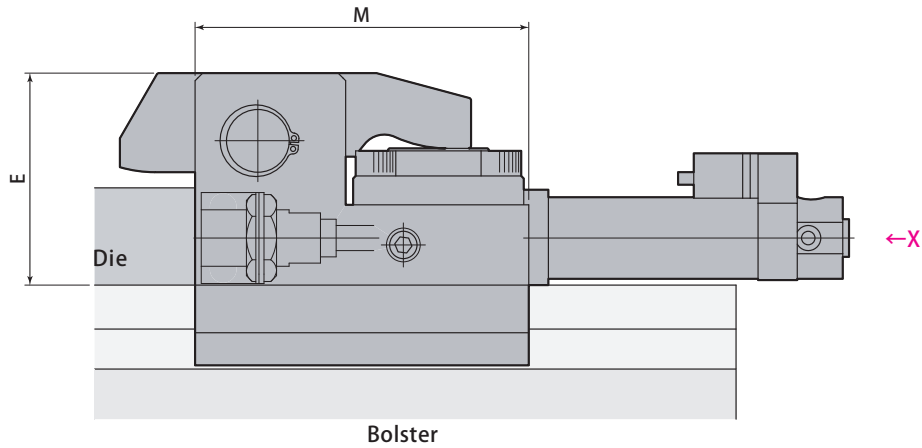

Rear piping
Hydraulic connection port U

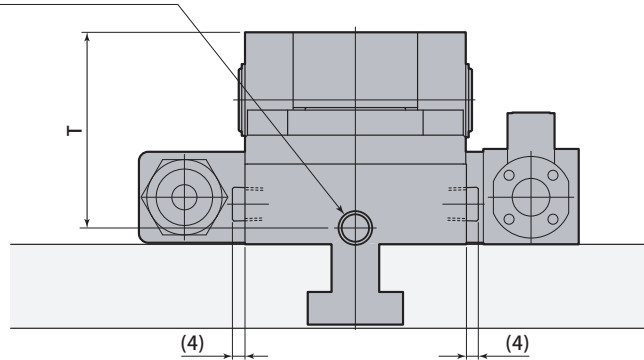

VIEW : X

Model	TYC040R-J	TYC063R-J	TYC100R-J	TYC160R-J	TYC250R-J
M	120	133	165	200	240
T	68	79	97	120	156
Hydraulic connection port U	Rc1/4	Rc1/4	Rc1/4	Rc1/4	Rc1/4
Min. E	79	90	107	132	168

● Lever height F varies according to the dimension h.

Model	TYC040R-J	TYC063R-J	TYC100R-J	TYC160R-J	TYC250R-J
Lever height F	47.5 (38 ≤ h)	29.5 (56.5 ≤ h)	45 (58 ≤ h)	60 (68 ≤ h)	76 (88 ≤ h)
Inside the parenthesis is range of h	42.5 (33 ≤ h < 47.5)	39.5 (46.5 ≤ h < 29.5)	55 (48 ≤ h < 58)	70 (58 ≤ h < 68)	86 (78 ≤ h < 88)
	37.5 (28 ≤ h < 42.5)	49.5 (36.5 ≤ h < 46.5)	65 (38 ≤ h < 48)	80 (48 ≤ h < 58)	96 (68 ≤ h < 78)

Automatic slidable TYC
Special type

W **Wide lever type** It is applied in case of clamping the die with U-cut.

Model designation

TYC 063 R 0 L - 075 - W

- 1 Clamping force ●
- 2 Proximity switch ●
- 3 Mounting position ●
of die detection proximity switch
- 4 Sliding stroke (mm) ●
* Indicated in 3 digits

1 2 3 4 Refer to page → 104

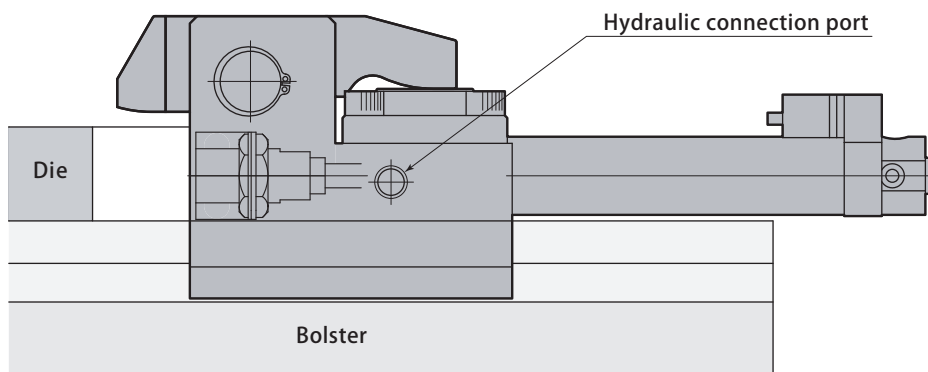
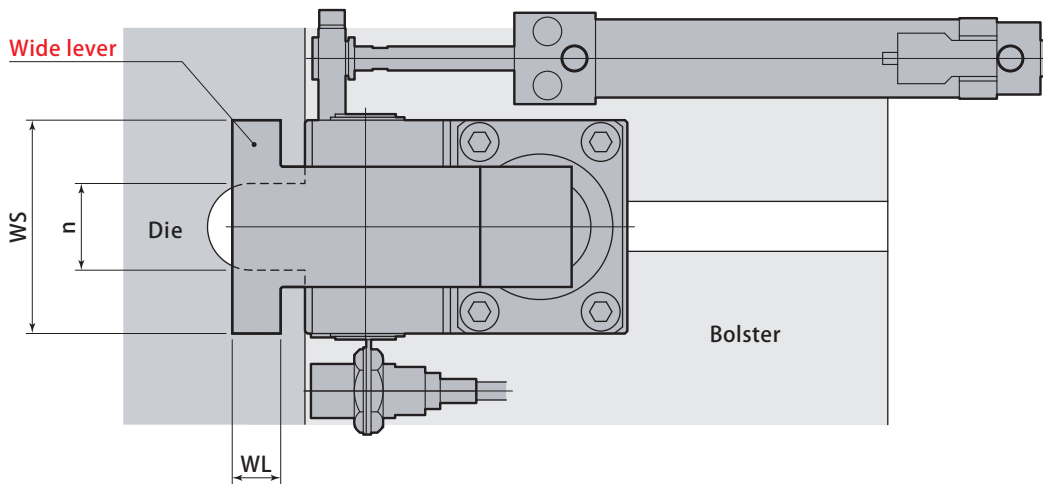

mm

Model	TYC020R-W	TYC040R-W	TYC063R-W	TYC100R-W	TYC160R-W	TYC250R-W
WS	62	72	88	88	100	110
WL	13	15	20	20	20	20
Max. n	32	32	36	32	40	40



Die-lifter model **DLF**

Die-lifter



A powerful hydraulic cylinder in the body lifts up die from the bolster and makes die transfer easy.



Die-lifter DLF Selection

Model designation

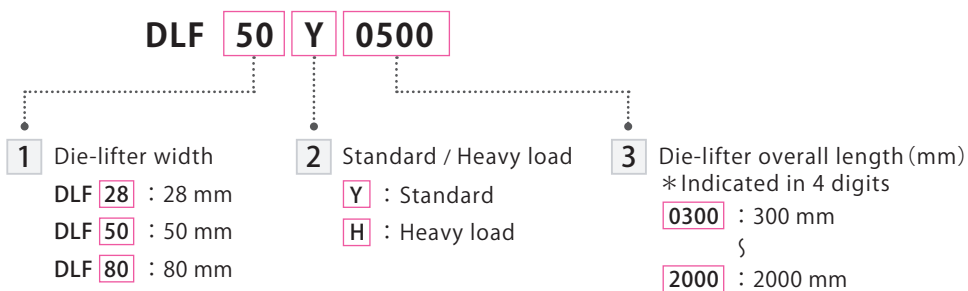

1 2 Specifications

Model		DLF28	DLF50	DLF80
Lifting stroke N	mm	3		4
Max. load per roller	kN	0.98	1.86	5
Lifting force per cylinder (at hydraulic pressure 24.5MPa)	kN	4.45	12	33.9
Cylinder capacity (per cylinder)	cm ³	0.54	1.5	5.6
Weight per 100 mm	Y (Standard)	0.66	1.5	3.6
	H (Heavy load)	0.7	1.6	3.8
Standard length	mm	300 ~ 2000	400 ~ 2000	500 ~ 2000
Die-lifter width A	mm	28	50	80
Slot depth B	mm	45	53	80
Roller diameter	mm	ø21	ø22	ø34
Roller width	mm	17	28	54

- Max. hydraulic pressure : 24.5MPa ● Proof pressure : 36.7MPa ● Operating temperature : 0 ~ 70°C
- DLF50 roller is more durable than the one of DLF28, so DLF50 is recommendable. ● DLF80 is the specification for large press machine (more than 8000kN).
- Roller max load is determined given die plate material as SS400(JIS). Consult Pascal in case the material is S45C.

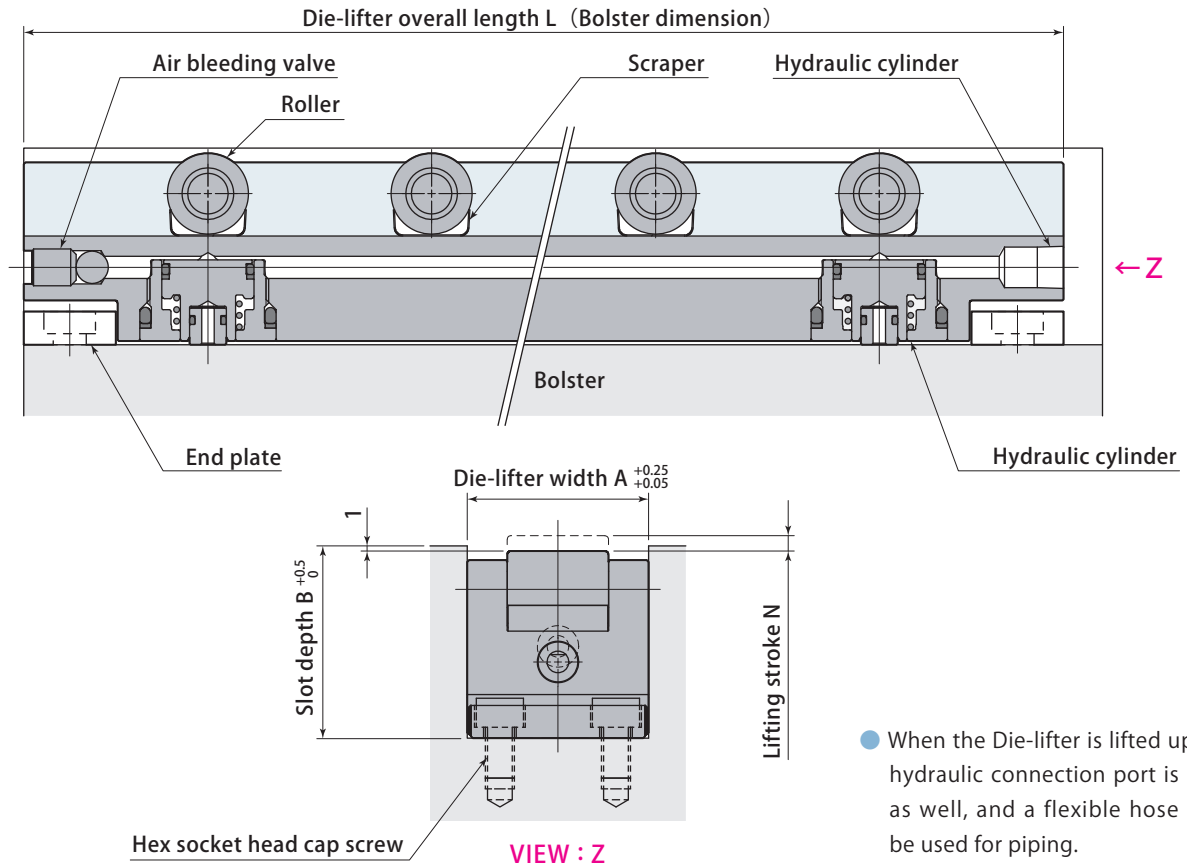

● When the Die-lifter is lifted up, the hydraulic connection port is lifted as well, and a flexible hose must be used for piping.

3 Die-lifter overall length 300 ~ 2000 mm

Die-lifter overall length L		mm	300	400	500	600	700	800	900	1000	1100	1200	1300	1400	1500	1600	1700	1800	2000				
DLF28Y	Number of rollers		3	4	5	6	7	8	9	10	11	12	13	14	15	16	17	18	20				
	Max. load per 100 mm	kN	0.98																				
	Max. load per overall length*	kN	2.94	3.92	4.9	5.88	6.86	7.84	8.82	9.8	10.8	11.8	12.7	13.7	14.7	15.7	16.7	17.6	19.6				
	Number of cylinders		3			4				5					6								
DLF28H	Number of rollers		6	8	10	12	14	15	17	19	21	23	25	27	29	31	33	35	39				
	Max. load per 100 mm	kN	1.96																				
	Max. load per overall length*	kN	5.88	7.84	9.8	11.8	13.7	14.7	16.7	18.6	20.6	22.5	24.5	26.5	28.4	30.4	32.3	34.3	38.2				
	Number of cylinders		4		5		6		7		8		9		10		11		12		13		14
DLF50Y	Number of rollers		—	4	5	6	7	8	9	10	11	12	13	14	15	16	17	18	20				
	Max. load per 100 mm	kN	—	1.86																			
	Max. load per overall length*	kN	—	7.44	9.3	11.2	13	14.9	16.7	18.6	20.5	22.3	24.2	26	27.9	29.8	31.6	33.5	37.2				
	Number of cylinders		—	3				4				5											
DLF50H	Number of rollers		—	8	10	12	14	16	18	20	22	24	26	28	30	32	34	36	40				
	Max. load per 100 mm	kN	—	3.72																			
	Max. load per overall length*	kN	—	14.9	18.6	22.3	26	29.8	33.5	37.2	40.9	44.6	48.4	52.1	55.8	59.5	63.2	67	74.4				
	Number of cylinders		—	3		4			5			6			7			8		9			
DLF80Y	Number of rollers		—	—	3	4	5	6	7	8	9	10	11	12	13	14	15	16	18				
	Max. load per 100 mm	kN	—	—	3	3.33	3.57	3.75	3.89	4	4.09	4.17	4.23	4.29	4.33	4.38	4.41	4.44	4.5				
	Max. load per overall length*	kN	—	—	15	20	25	30	35	40	45	50	55	60	65	70	75	80	90				
	Number of cylinders		—	—	2		3			4				5									
DLF80H	Number of rollers		—	—	8	10	11	13	15	16	18	20	21	23	24	26	28	29	32				
	Max. load per 100 mm	kN	—	—	8	8.33	7.86	8.13	8.33	8	8.18	8.33	8.08	8.21	8	8.13	8.24	8.06	8				
	Max. load per overall length*	kN	—	—	40	50	55	65	75	80	90	100	105	115	120	130	140	145	160				
	Number of cylinders		—	—	3		4		5		6		7		8		9		10				

* The value indicates Max. load when all of rollers are in contact with the die.

Width 28mm Standard

Model designation

DLF 28 Y 0500

Die-lifter overall length (mm)
0300~2000 * Indicated in 4 digits

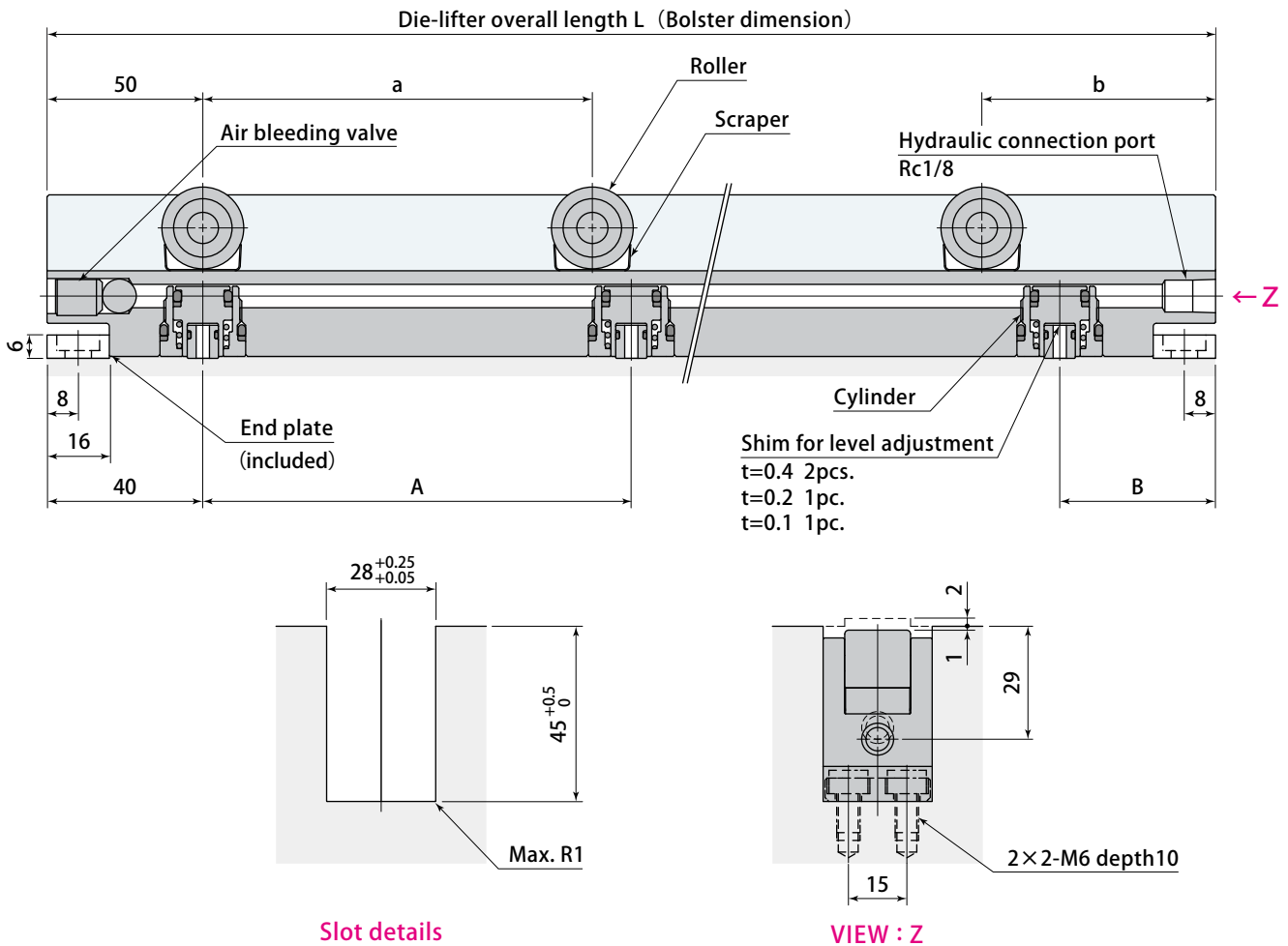

Die-lifter overall length **300 ~ 2000** mm

Die-lifter overall length L	mm	300	400	500	600	700	800	900	1000	1100	1200	1300	1400	1500	1600	1700	1800	2000	
Number of rollers		3	4	5	6	7	8	9	10	11	12	13	14	15	16	17	18	20	
Max. load per 100 mm	kN	0.98	0.98	0.98	0.98	0.98	0.98	0.98	0.98	0.98	0.98	0.98	0.98	0.98	0.98	0.98	0.98	0.98	
Max. load per overall length *	kN	2.94	3.92	4.9	5.88	6.86	7.84	8.82	9.8	10.8	11.8	12.7	13.7	14.7	15.7	16.7	17.6	19.6	
Roller pitch	a	mm	100	100	100	100	100	100	100	100	100	100	100	100	100	100	100	100	
	b	mm	50	50	50	50	50	50	50	50	50	50	50	50	50	50	50	50	
Number of cylinders		3	3	3	3	4	4	4	4	5	5	5	5	5	5	5	6	6	
Lifting force per cylinder	kN	13.4	13.4	13.4	13.4	17.8	17.8	17.8	17.8	22.3	22.3	22.3	22.3	22.3	22.3	22.3	26.7	26.7	
Cylinder capacity	cm ³	1.62	1.62	1.62	1.62	2.16	2.16	2.16	2.16	2.7	2.7	2.7	2.7	2.7	2.7	2.7	3.24	3.24	
Cylinder pitch	A	mm	110	160	210	260	207	240	274	307	255	280	305	330	355	380	405	344	384
	B	mm	40	40	40	40	39	40	38	39	40	40	40	40	40	40	40	40	40
Weight	kg	2	2.6	3.3	4	4.6	5.3	5.9	6.6	7.3	7.9	8.6	9.2	9.9	10.6	11.2	11.9	13.2	
End plate mount screw		4-M6 length10																	

- Max. hydraulic pressure : 24.5MPa
- Lifting force is under hydraulic force at 24.5 MPa.
- Proof pressure : 36.7MPa
- Operating temperature : 0 ~ 70°C
- * The value indicates Max. load when all of rollers are in contact with the die.

Width 28mm Heavy load

Model designation

DLF 28 H 0500

Die-lifter overall length (mm)
0300~2000 *Indicated in 4 digits

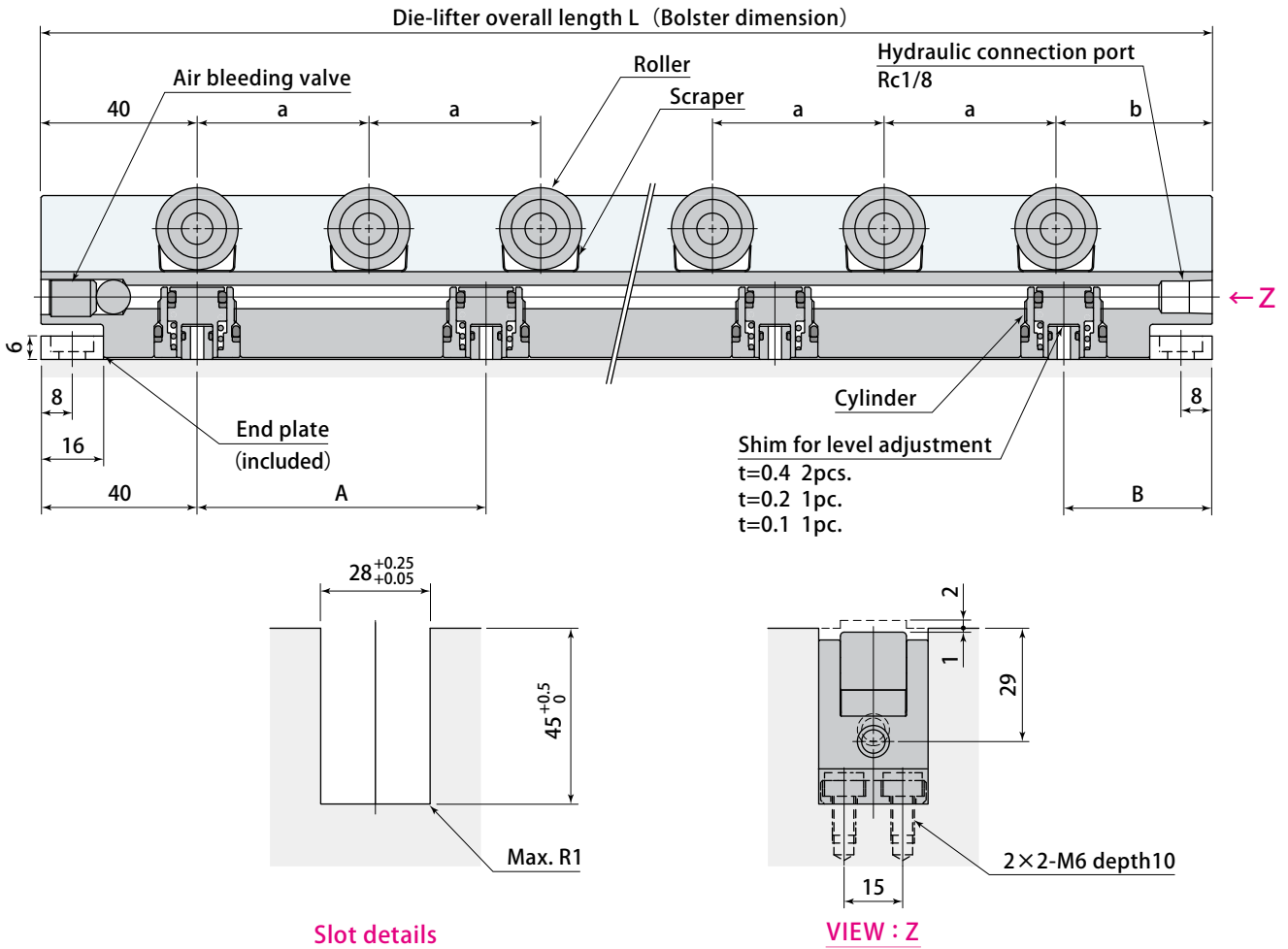

Die-lifter DLF28

Die-lifter overall length **300 ~ 2000** mm

Die-lifter overall length L	mm	300	400	500	600	700	800	900	1000	1100	1200	1300	1400	1500	1600	1700	1800	2000	
Number of rollers		6	8	10	12	14	15	17	19	21	23	25	27	29	31	33	35	39	
Max. load per 100 mm	kN	1.96	1.96	1.96	1.96	1.96	1.84	1.85	1.86	1.87	1.88	1.88	1.89	1.89	1.9	1.9	1.91	1.91	
Max. load per overall length*	kN	5.88	7.84	9.8	11.8	13.7	14.7	16.7	18.6	20.6	22.5	24.5	26.5	28.4	30.4	32.3	34.3	38.2	
Roller pitch	a	mm	44	45	46	47	47	51	51	51	51	50	50	50	50	50	50	50	
	b	mm	40	45	46	43	49	46	44	42	40	60	60	60	60	60	60	60	
Number of cylinders		4	4	5	5	6	7	7	8	9	9	10	11	11	12	13	13	14	
Lifting force per cylinder	kN	17.8	17.8	22.3	22.3	26.7	31.2	31.2	35.6	40.1	40.1	44.5	49	49	53.4	57.9	57.9	62.3	
Cylinder capacity	cm ³	2.16	2.16	2.7	2.7	3.24	3.78	3.78	4.32	4.86	4.86	5.4	5.94	5.94	6.48	7.02	7.02	7.56	
Cylinder pitch	A	mm	74	106	105	130	124	120	136	132	128	140	135	132	142	138	135	143	147
	B	mm	38	42	40	40	40	40	44	36	36	40	45	40	40	42	40	44	49
Weight	kg	2.1	2.8	3.5	4.2	4.9	5.6	6.3	7	7.7	8.4	9.1	9.8	10.5	11.2	11.9	12.6	14	
End plate mount screw		4-M6 length 10																	

● Max. hydraulic pressure : 24.5MPa ● Lifting force is under hydraulic force at 24.5 MPa. ● Proof pressure : 36.7MPa

● Operating temperature : 0 ~ 70°C

* The value indicates Max. load when all of rollers are in contact with the die.

Width 50mm Standard

Model designation

DLF 50 Y 0500

Die-lifter overall length (mm)
0300~2000 * Indicated in 4 digits

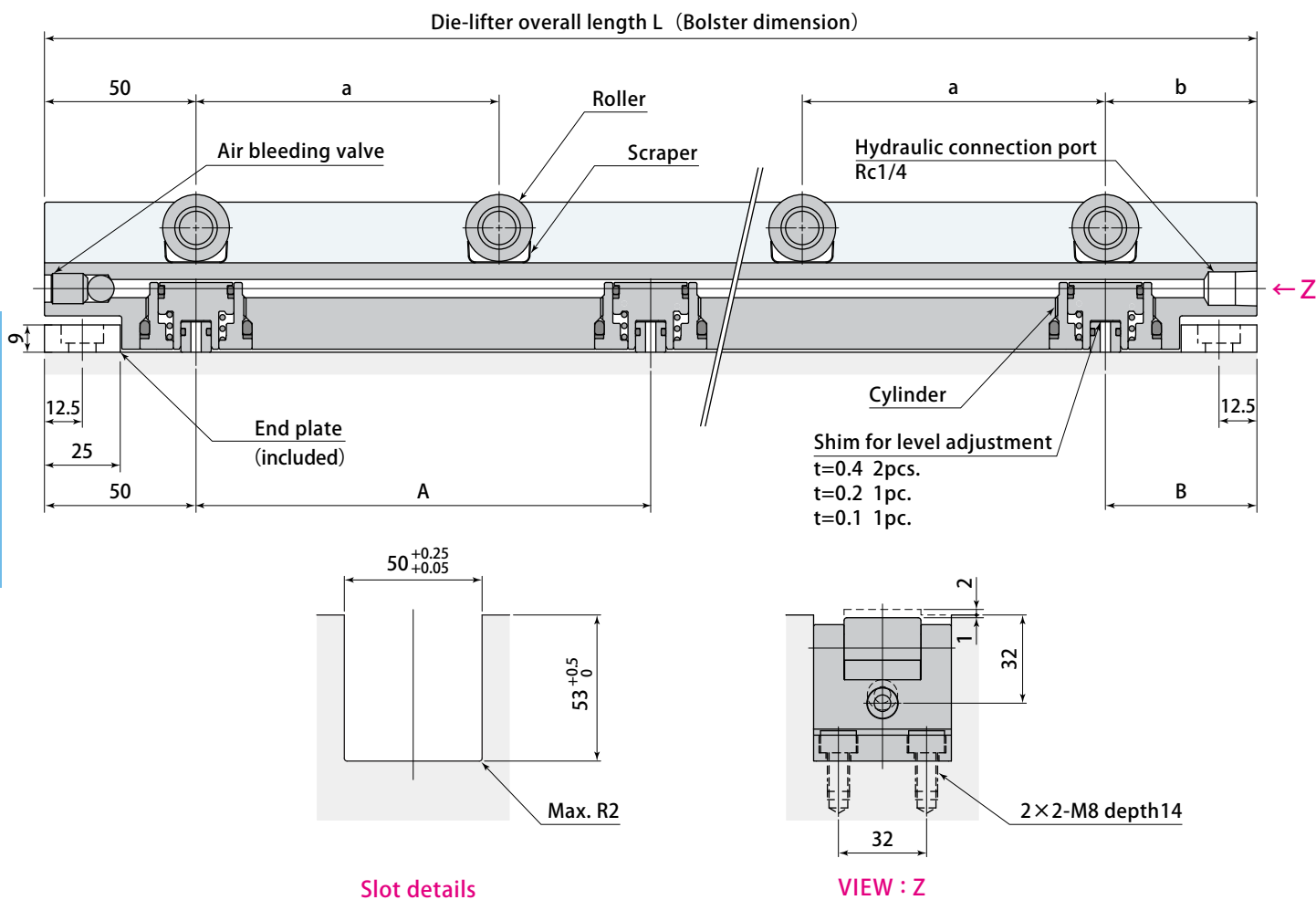

Slot details

VIEW : Z

Die-lifter overall length 400 ~ 2000 mm

Die-lifter overall length L	mm	400	500	600	700	800	900	1000	1100	1200	1300	1400	1500	1600	1700	1800	2000	
Number of rollers		4	5	6	7	8	9	10	11	12	13	14	15	16	17	18	20	
Max. load per 100 mm	kN	1.86	1.86	1.86	1.86	1.86	1.86	1.86	1.86	1.86	1.86	1.86	1.86	1.86	1.86	1.86	1.86	
Max. load per overall length *	kN	7.44	9.3	11.2	13	14.9	16.7	18.6	20.5	22.3	24.2	26	27.9	29.8	31.6	33.5	37.2	
Roller pitch	a	mm	100	100	100	100	100	100	100	100	100	100	100	100	100	100	100	
	b	mm	50	50	50	50	50	50	50	50	50	50	50	50	50	50	50	
Number of cylinders		3	3	3	3	3	4	4	4	4	4	4	5	5	5	5	5	
Lifting force per cylinder	kN	36	36	36	36	36	48	48	48	48	48	48	60	60	60	60	60	
Cylinder capacity	cm ³	4.5	4.5	4.5	4.5	4.5	6	6	6	6	6	6	7.5	7.5	7.5	7.5	7.5	
Cylinder pitch	A	mm	150	200	250	300	350	267	300	334	367	400	434	350	375	400	425	475
	B	mm	50	50	50	50	50	49	50	48	49	50	48	50	50	50	50	50
Weight	kg	6	7.5	9	10.5	12	13.5	15	16.5	18	19.5	21	22.5	24	25.5	27	30	
End plate mount screw		4-M8 length14																

- Max. hydraulic pressure : 24.5MPa ● Lifting force is under hydraulic force at 24.5 MPa. ● Proof pressure : 36.7MPa
- Operating temperature : 0 ~ 70°C * The value indicates Max. load when all of rollers are in contact with the die.

Width 50mm Heavy load

Model designation

DLF 50 H 0500

Die-lifter overall length (mm)
0400~2000 * Indicated in 4 digits

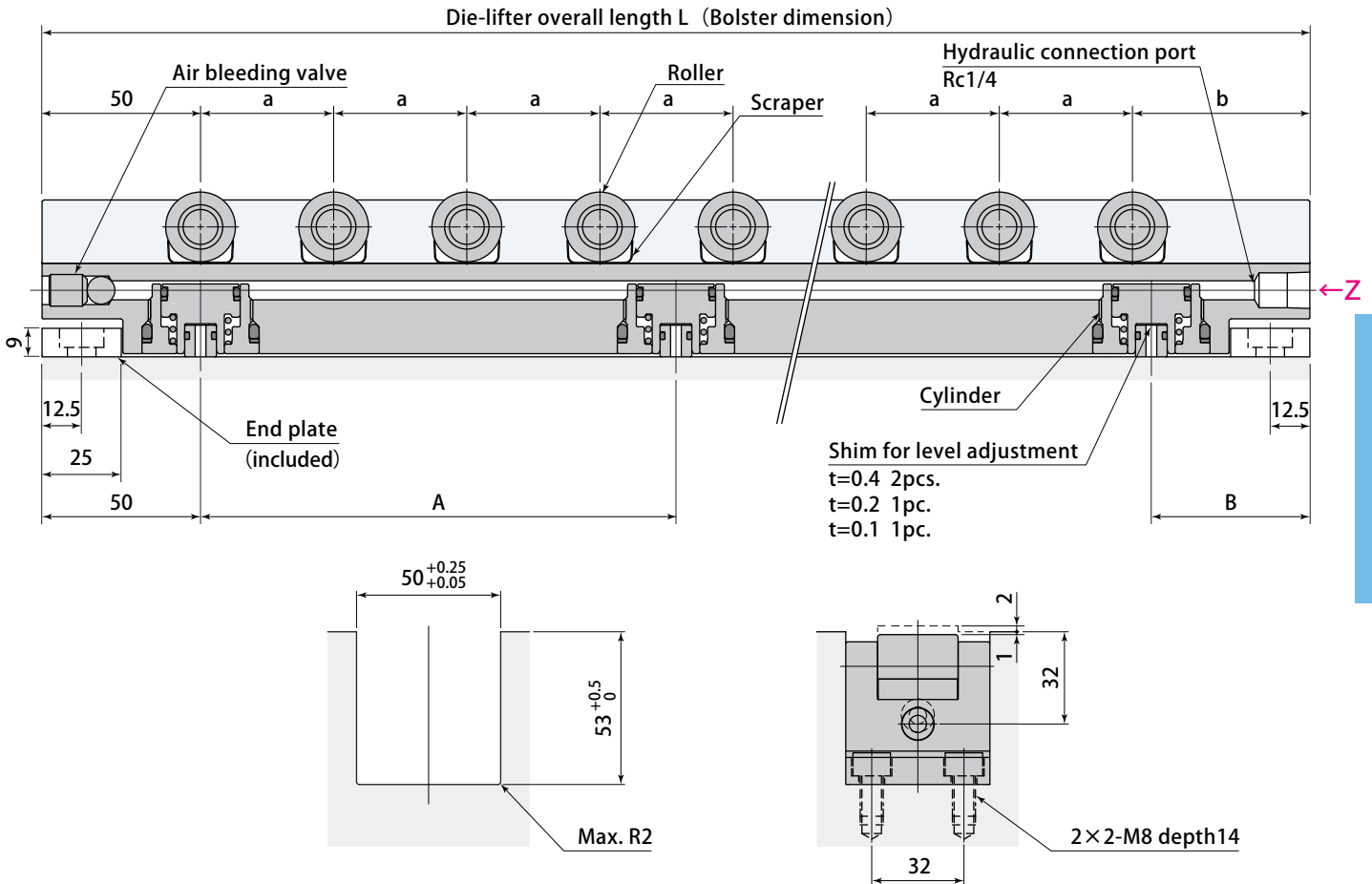

Die-lifter DLF50

Slot details

VIEW : Z

Die-lifter overall length **400 ~ 2000** mm

Die-lifter overall length L	mm	400	500	600	700	800	900	1000	1100	1200	1300	1400	1500	1600	1700	1800	2000
Number of rollers		8	10	12	14	16	18	20	22	24	26	28	30	32	34	36	40
Max. load per 100 mm	kN	3.72	3.72	3.72	3.72	3.72	3.72	3.72	3.72	3.72	3.72	3.72	3.72	3.72	3.72	3.72	3.72
Max. load per overall length *	kN	14.9	18.6	22.3	26	29.8	33.5	37.2	40.9	44.6	48.4	52.1	55.8	59.5	63.2	67	74.4
Roller pitch	a	mm	42	44	45	46	46	47	47	47	47	48	48	48	48	48	48
	b	mm	56	54	55	52	60	51	57	63	69	50	54	58	62	66	70
Number of cylinders		3	3	4	4	4	5	5	6	6	6	7	7	7	8	8	9
Lifting force per cylinder	kN	36	36	48	48	48	60	60	72	72	72	84	84	84	96	96	108
Cylinder capacity	cm ³	4.5	4.5	6	6	6	7.5	7.5	9	9	9	10.5	10.5	10.5	12	12	13.5
Cylinder pitch	A	mm	150	200	166	200	233	200	225	200	220	240	216	233	250	228	242
	B	mm	50	50	52	50	51	50	50	50	50	54	52	50	54	56	54
Weight	kg	6.4	8	9.6	11.2	12.8	14.4	16	17.6	19.2	20.8	22.4	24	25.6	27.2	28.8	32
End plate mount screw		4-M8 length14															

● Max. hydraulic pressure : 24.5MPa ● Lifting force is under hydraulic force at 24.5 MPa. ● Proof pressure : 36.7MPa

● Operating temperature : 0 ~ 70°C

* The value indicates Max. load when all of rollers are in contact with the die.

Width 80mm Standard

Model designation

DLF 80 Y 0500

Die-lifter overall length (mm)
0500~2000 * Indicated in 4 digits

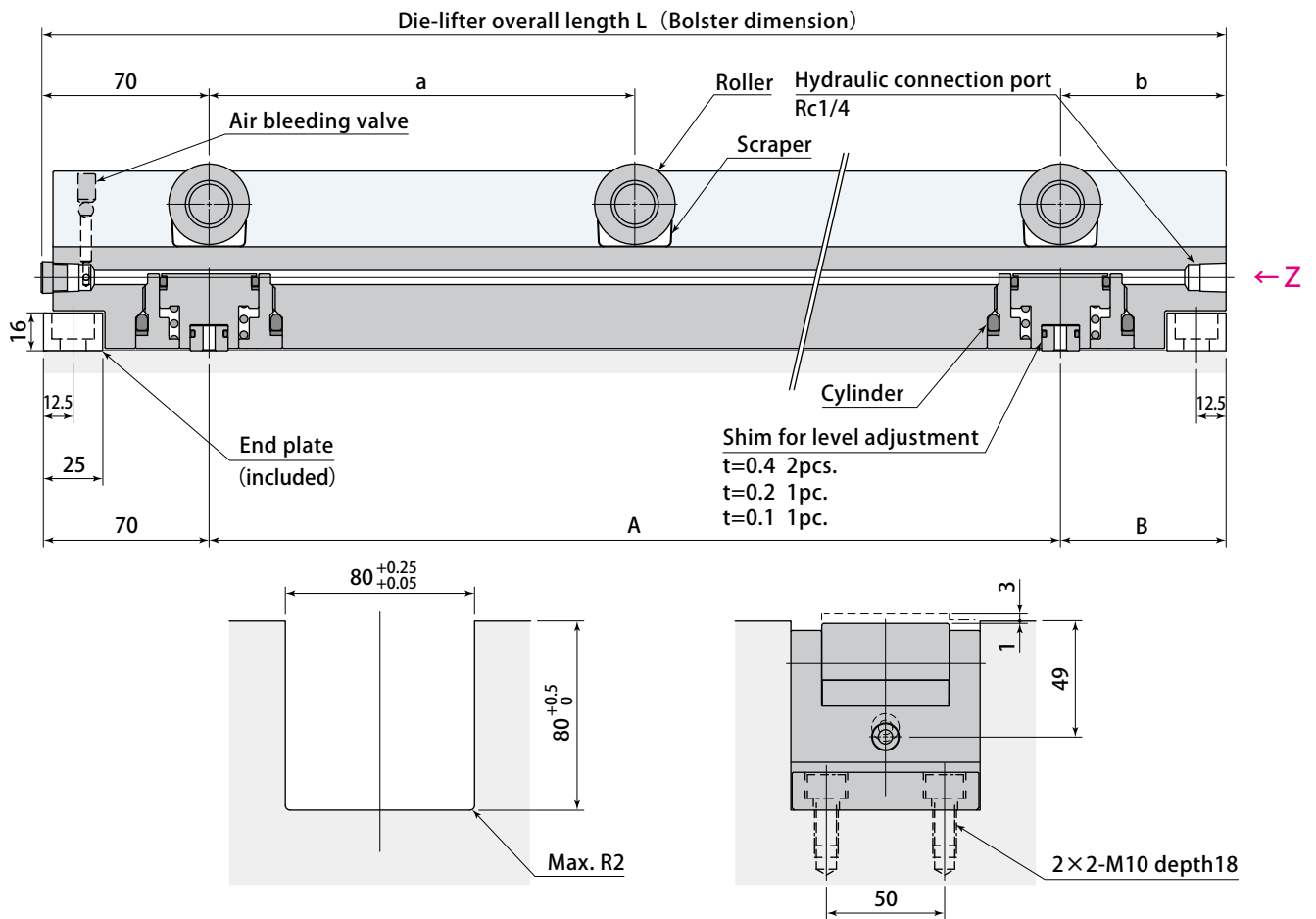

Slot details

Die-lifter overall length 500 ~ 2000 mm

Die-lifter overall length L	mm	500	600	700	800	900	1000	1100	1200	1300	1400	1500	1600	1700	1800	2000	
Number of rollers		3	4	5	6	7	8	9	10	11	12	13	14	15	16	18	
Max. load per 100 mm	kN	3	3.33	3.57	3.75	3.89	4	4.09	4.17	4.23	4.29	4.33	4.38	4.41	4.44	4.5	
Max. load per overall length *	kN	15	20	25	30	35	40	45	50	55	60	65	70	75	80	90	
Roller pitch	a	mm	180	153	140	132	126	122	120	117	116	114	113	112	111	109	
	b	mm	70	71	70	70	74	76	70	77	70	76	74	74	76	77	
Number of cylinders		2	2	3	3	3	3	3	4	4	4	4	5	5	5	5	
Lifting force per cylinder	kN	67.8	67.8	101.7	101.7	101.7	101.7	101.7	135.6	135.6	135.6	135.6	169.5	169.5	169.5	169.5	
Cylinder capacity	cm ³	11.2	11.2	16.8	16.8	16.8	16.8	16.8	22.4	22.4	22.4	22.4	28	28	28	28	
Cylinder pitch	A	mm	360	460	280	330	380	430	480	353	387	420	453	365	390	415	465
	B	mm	70	70	70	70	70	70	70	71	69	70	71	70	70	70	70
Weight	kg	18	21.6	25.2	28.8	32.4	36	39.6	43.2	46.8	50.4	54	57.6	61.2	64.8	72	
End plate mount screw		4-M10 length 20															

- Max. hydraulic pressure : 24.5MPa ● Lifting force is under hydraulic force at 24.5 MPa. ● Proof pressure : 36.7MPa
- Operating temperature : 0 ~ 70°C

* The value indicates Max. load when all of rollers are in contact with the die.

Width 80mm Heavy load

Model designation

DLF 80 H 0500

Die-lifter overall length (mm)
0500~2000 * Indicated in 4 digits

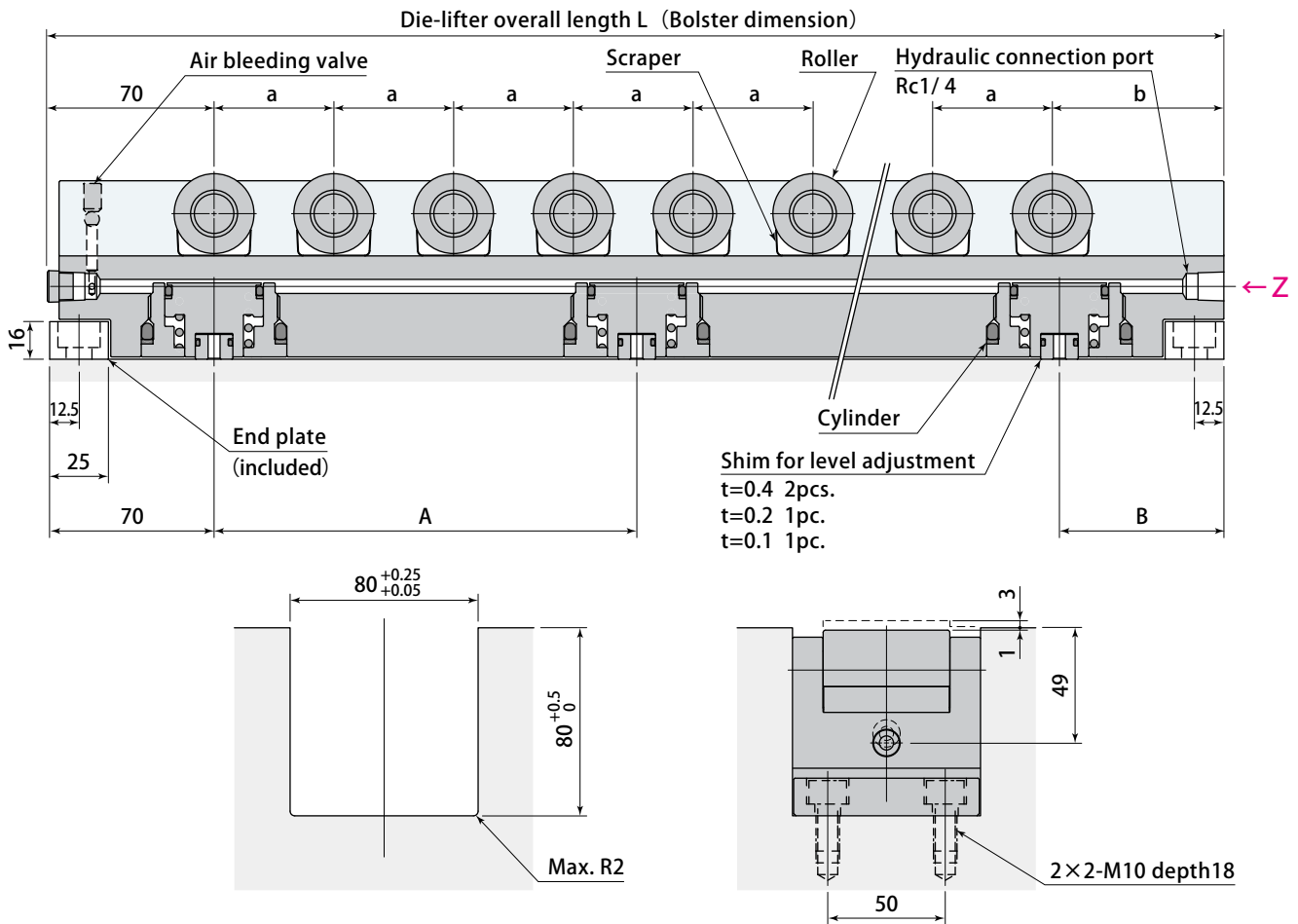

Slot details

VIEW : Z

Die-lifter overall length 500 ~ 2000 mm

Die-lifter overall length L	mm	500	600	700	800	900	1000	1100	1200	1300	1400	1500	1600	1700	1800	2000
Number of rollers		8	10	11	13	15	16	18	20	21	23	24	26	28	29	32
Max. load per 100 mm	kN	8	8.33	7.86	8.13	8.33	8	8.18	8.33	8.08	8.21	8	8.13	8.24	8.06	8
Max. load per overall length *	kN	40	50	55	65	75	80	90	100	105	115	120	130	140	145	160
Roller pitch	a	mm	51	51	56	55	54	57	56	55	58	57	59	58	57	60
	b	mm	73	71	70	70	74	75	78	85	70	76	73	80	91	70
Number of cylinders		3	3	4	4	5	5	6	6	7	7	8	8	9	9	10
Lifting force per cylinder	kN	101.7	101.7	135.6	135.6	169.5	169.5	203.4	203.4	237.3	237.3	271.2	271.2	305.1	305.1	339
Cylinder capacity	cm ³	16.8	16.8	22.4	22.4	28	28	33.6	33.6	39.2	39.2	44.8	44.8	50.4	50.4	56
Cylinder pitch	A	mm	180	230	187	220	190	215	192	212	194	210	195	209	195	207
	B	mm	70	70	69	70	70	70	70	70	66	70	65	67	70	66
Weight	kg	19	22.8	26.6	30.4	34.2	38	41.8	45.6	49.4	53.2	57	60.8	64.6	68.4	76
End plate mount screw		4-M10 length 20														

● Max. hydraulic pressure : 24.5MPa ● Lifting force is under hydraulic force at 24.5 MPa. ● Proof pressure : 36.7MPa

● Operating temperature : 0 ~ 70°C

* The value indicates Max. load when all of rollers are in contact with the die.

P P type stopper

Die-lifter can be inserted/removed.
(End plate included)

Model designation

DLF **50** **Y** **0500** **P**

- 1 Die-lifter width *1
- 2 Y:Standard H:Heavy load
- 3 Die-lifter overall length (mm)
* Indicated in 4 digits

*1 Die-lifter width
P type stopper is only for DLF28, DLF50.
It does not correspond to DLF80 (Width 80mm).

1 2 3 Refer to pages → 115 ~ 116

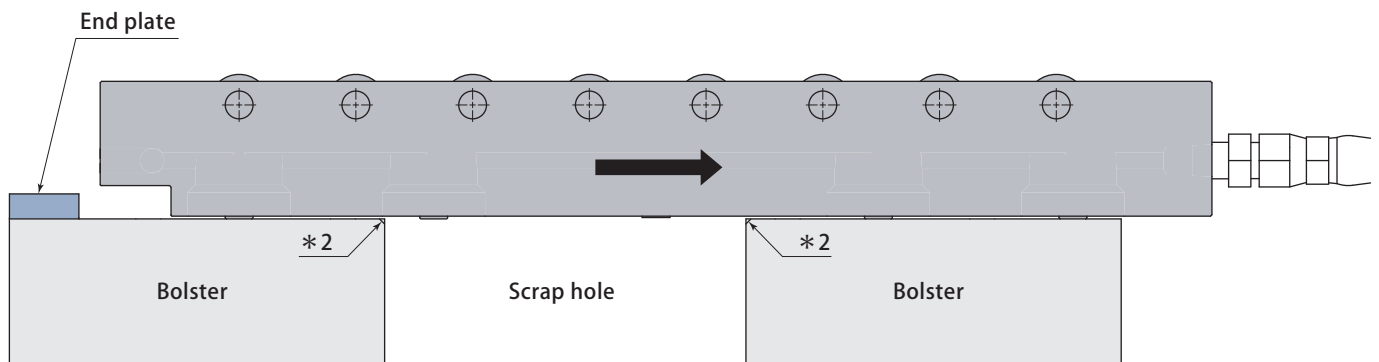
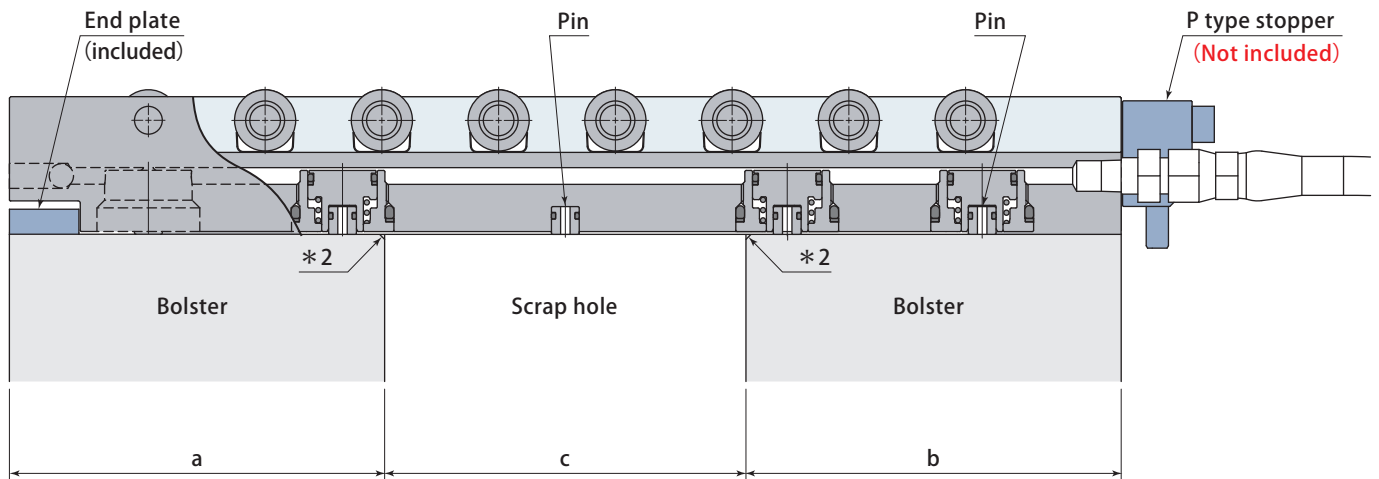

- Indicate scrap hole dimensions a, b and c.
 - When the scrap hole is wide, a pin is provided at center.
 - P type stopper is not included. Order it separately.
 - If Die-lifter is used at T-slot, process T-slot according to Die-lifter.
- *2 : Chamfer the edge of bolster to evade the protrusion of the pin from the bottom when removal DLF.

Die-lifter DLF
Scrap hole type

P type stopper They are accessories for P type stopper.

Model designation

Lever direction (stopper installed position)

DLF - P **L** : Lever direction left (Right mounting)
R : Lever direction right (Left mounting)

P type stopper model	DLF-PL / DLF-PR
Stopper mount screw	2-M8 length 35
Spring washer	2-M8

L : Lever direction left (Right mounting)

R : Lever direction right (Left mounting)

Locked

Locked

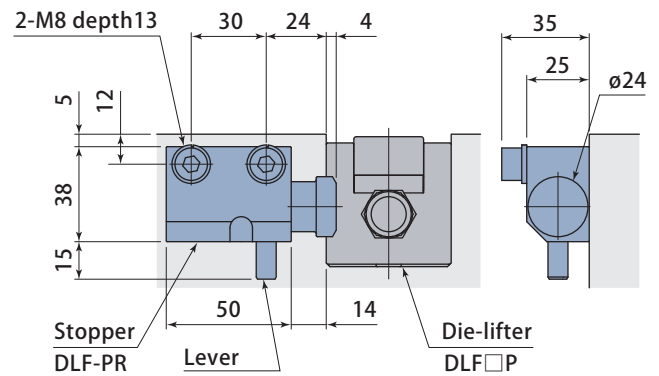
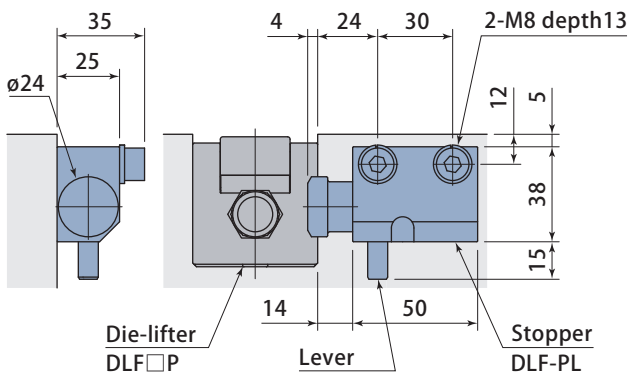

Unlocked

Unlocked

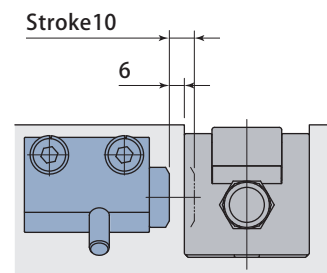
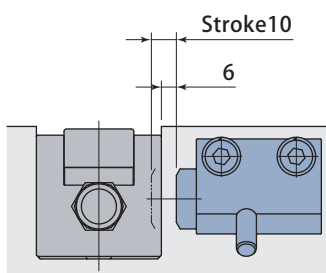

Die-lifter DLF□
 Scrap hole type

Die-lifter DLF□P Stopper P

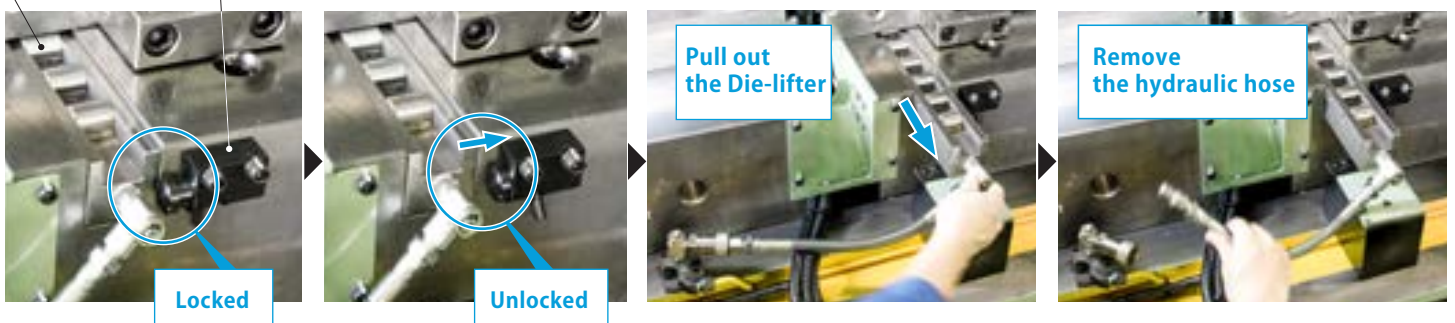

A A type stopper

Die-lifter can be inserted/removed.
(End plate included)

Model designation

DLF 50 Y 0500 A

- 1 Die-lifter width *1
 - 2 Y:Standard H:Heavy load
 - 3 Die-lifter overall length (mm)
- * Indicated in 4 digits

*1 Die-lifter width
A type stopper is only for DLF28, DLF50.
It does not correspond to DLF80 (Width 80mm)

1 2 3 Refer to **pages** → 115 ~ 116

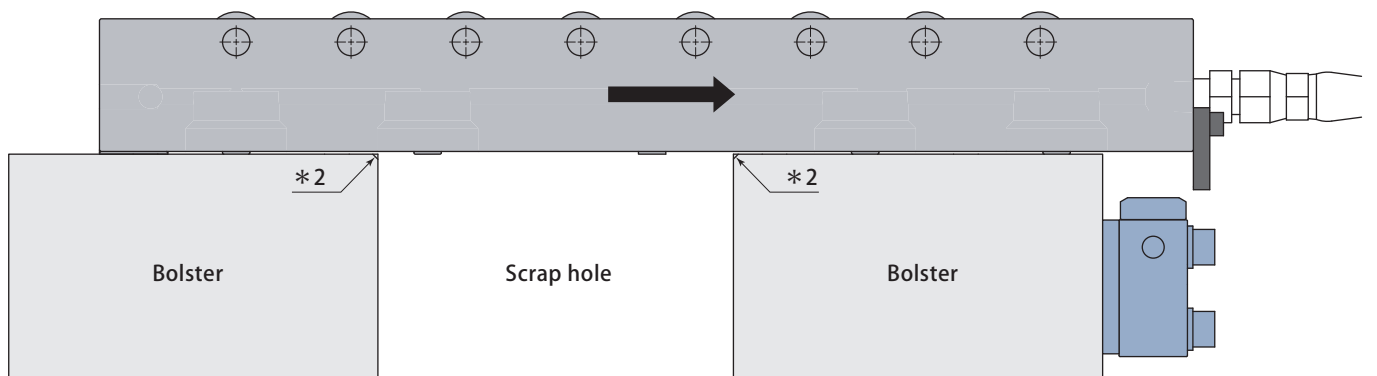
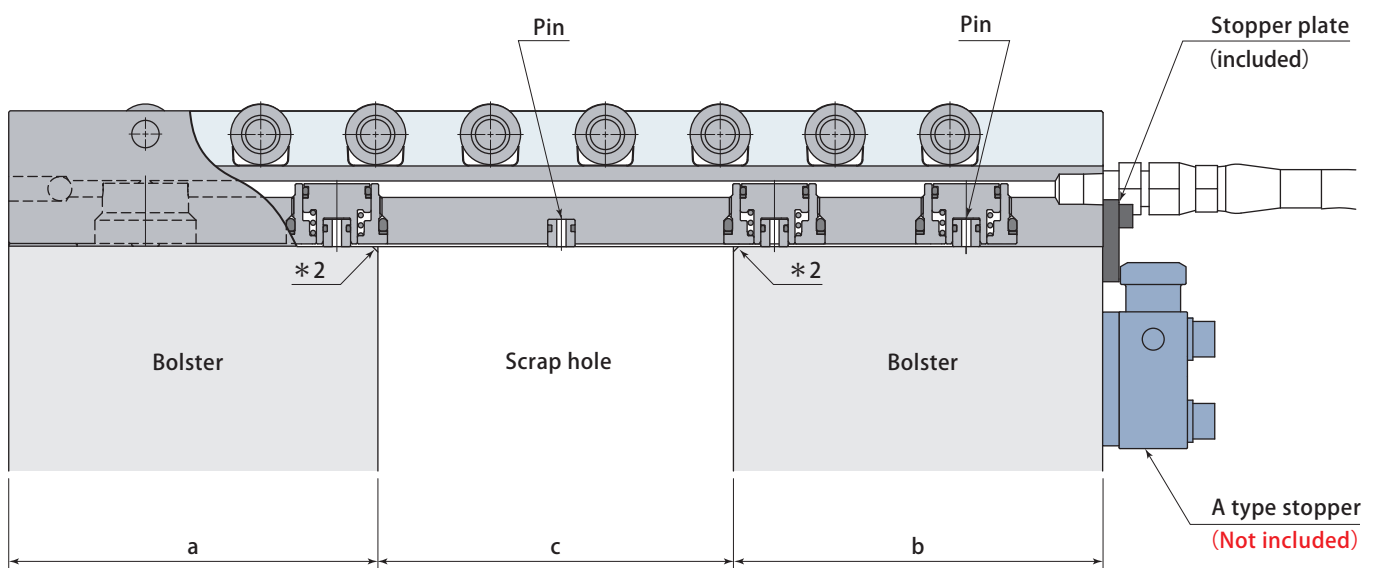

- Indicate scrap hole dimensions a, b and c.
 - When the scrap hole is wide, a pin is provided at center.
 - Include Stopper plate in Pascal Die-lifter.
 - A type stopper is not included. Order it separately.
 - If Die-lifter is used at T-slot, process T-slot according to Die-lifter.
- *2 : Chamfer the edge of bolster to evade the protrusion of the pin from the bottom when removal DLF.

Die-lifter DLF
Scrap hole type

A type stopper They are accessories for A type stopper.

Model designation

Lever direction
DLF - A **L** :Lever left side
R :Lever right side

A type stopper model		DLF-AL / DLF-AR	
Die-lifter model		DLF28	DLF50
Lifting stroke		3	3
Plate size	A	26	48
	F	20	30
	C	18	34
	D	5	6
	E	5	11
Slot depth		B	53
Mount detail	G	30	34
	H	17	12
Stopper mount screw		2-M8 length 40	
Spring washer		2-M8	

mm

Locked

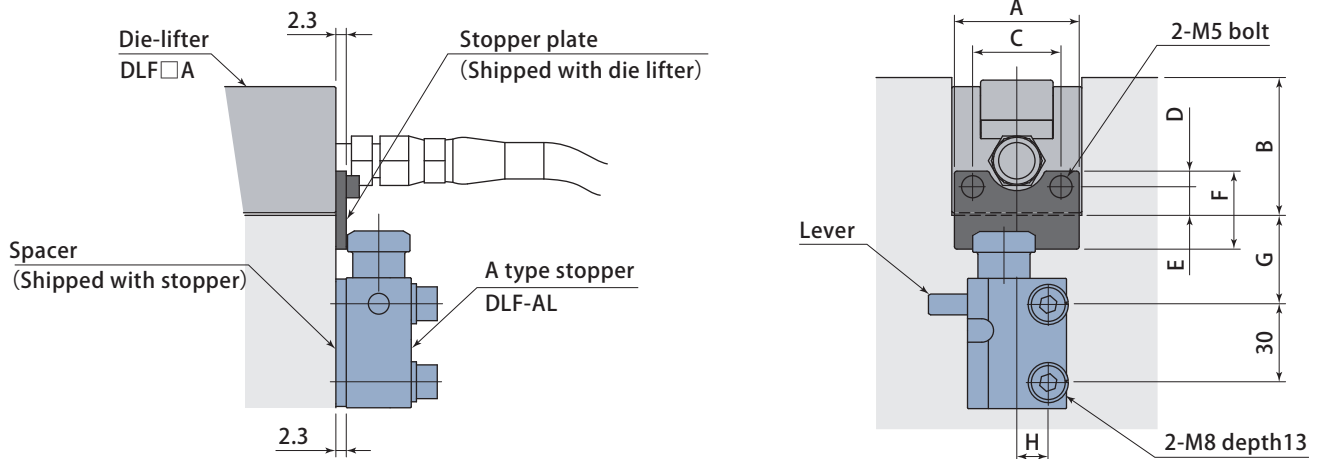

Unlocked

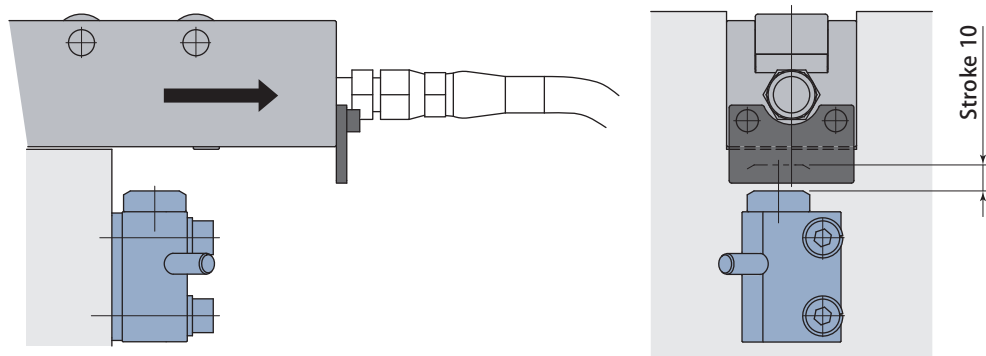

● These drawings indicate : for lever left side **L**

Die-lifter **DLF** □
 Scrap hole type

C C type key stopper

Two Die-lifters are set up per T-slotted bolster.

Model designation

DLF **50** **H** **0500** **C**

- 1 Die-lifter width *1
 - 2 H: Heavy load *2
 - 3 Die-lifter overall length (mm)
- * Indicated in 4 digits

- *1 Die-lifter width
C type stopper is only for DLF28, DLF50.
It does not correspond to DLF80(Width 80mm).
- *2 It does not correspond to the standard Y type.

1 2 3 Refer to pages → 115 ~ 116

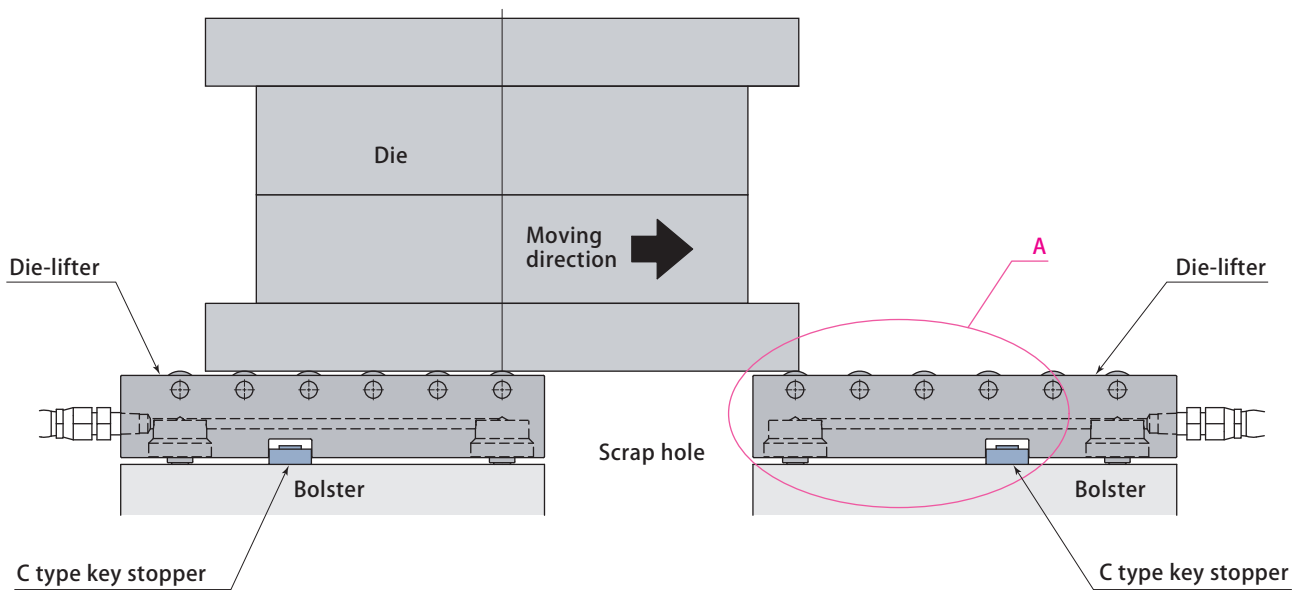

Die-lifter DLF
Scrap hole type

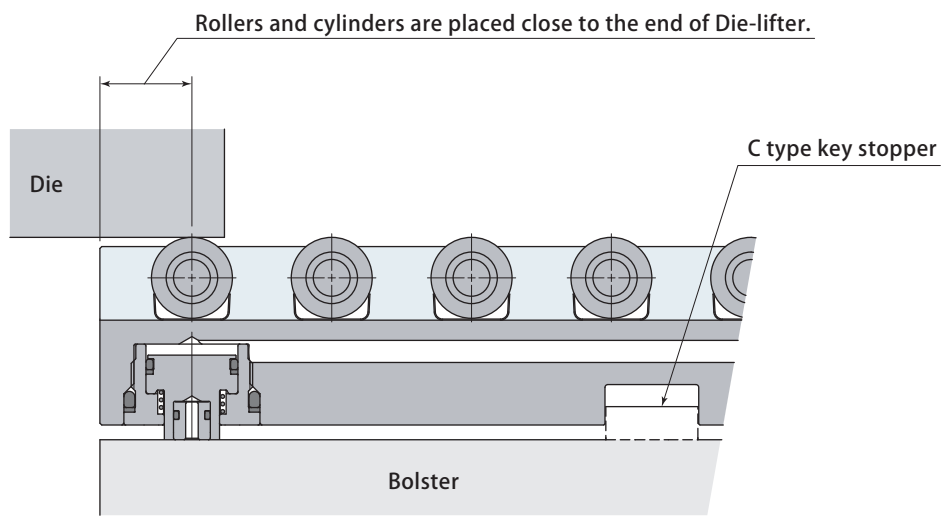

Details:A

- Indicate Die-lifter overall length and die weight.
- Rollers and cylinders are placed close to the end of Die-lifter. Die can be moved smoothly over the scrap hole.
- This model has no Air bleeding valve, loosen pipe fitting for air bleeding.

Reference specification

C type key stopper DLF28H

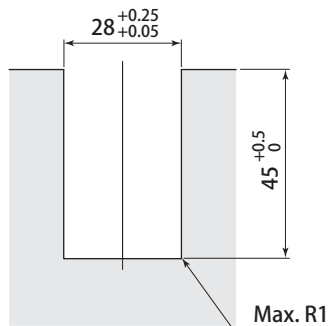
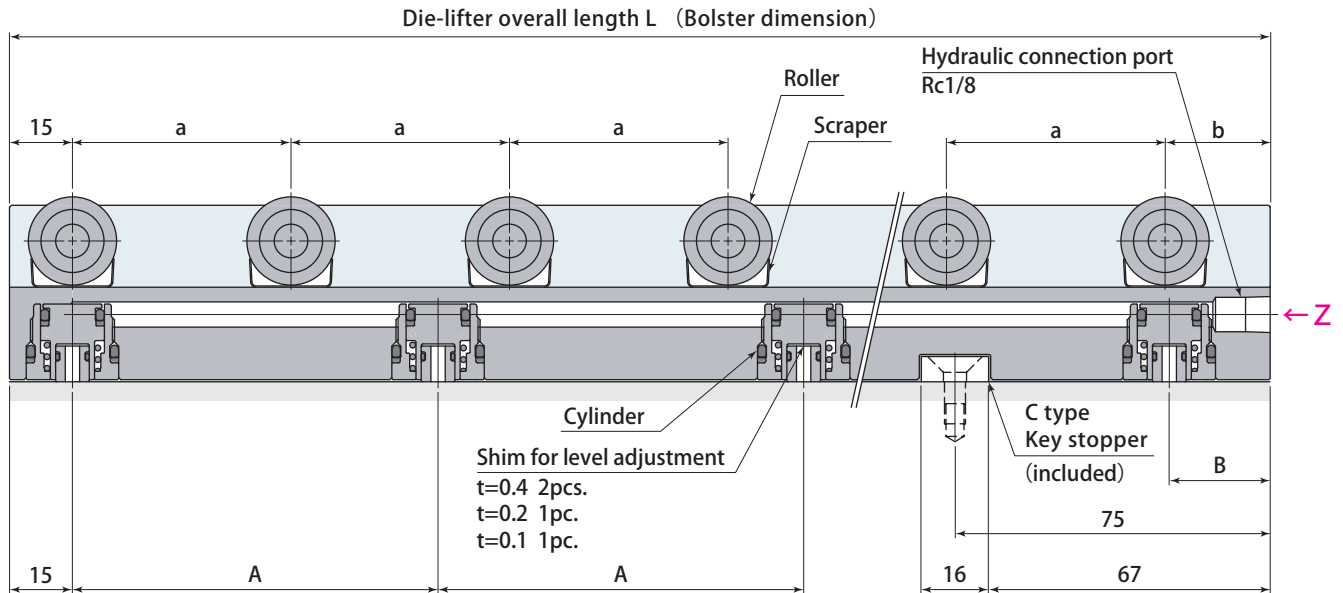

Slot details

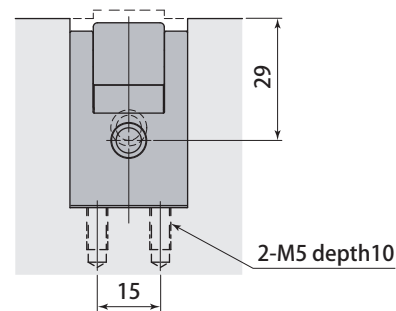

VIEW : Z

Die-lifter DLF
Scrap hole type

Die-lifter overall length L	mm	200	225	250	275	300	325	350	375	400	
Number of rollers		4	4	5	6	6	6	7	8	8	
Max. load per 100 mm	kN	1.96	1.74	1.96	2.14	1.96	1.81	1.96	2.09	1.96	
Max. load per overall length*	kN	3.92	3.92	4.9	5.88	5.88	5.88	6.86	7.84	7.84	
Roller pitch	a	mm	53	61	52	47	52	57	51	47	51
	b	mm	26	27	27	25	25	25	29	31	28
Number of cylinders		2	2	3	4	4	4	4	4	4	
Lifting force per cylinder	kN	8.9	8.9	13.4	17.8	17.8	17.8	17.8	17.8	17.8	
Cylinder capacity	cm ³	1.08	1.08	1.62	2.16	2.16	2.16	2.16	2.16	2.16	
Cylinder pitch	A	mm	160	185	105	78.5	87	95	103.5	112	120
	B	mm	25	25	25	24.5	24	25	24.5	24	25
Weight	kg	1.4	1.6	1.8	1.9	2.1	2.3	2.5	2.6	2.8	
Key stopper mount screw		2-M5 length10									

● Max. hydraulic pressure : 24.5 MPa ● Lifting force is under hydraulic force at 24.5 MPa. ● Proof pressure : 36.7 MPa

● Operating temperature : 0 ~ 70 °C

* The value indicates Max. load when all of rollers are in contact with the die.

Reference specification

C type key stopper DLF50H

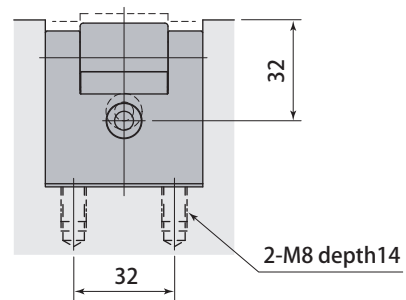
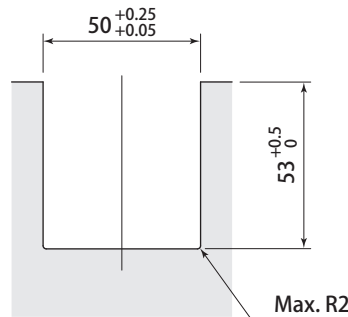
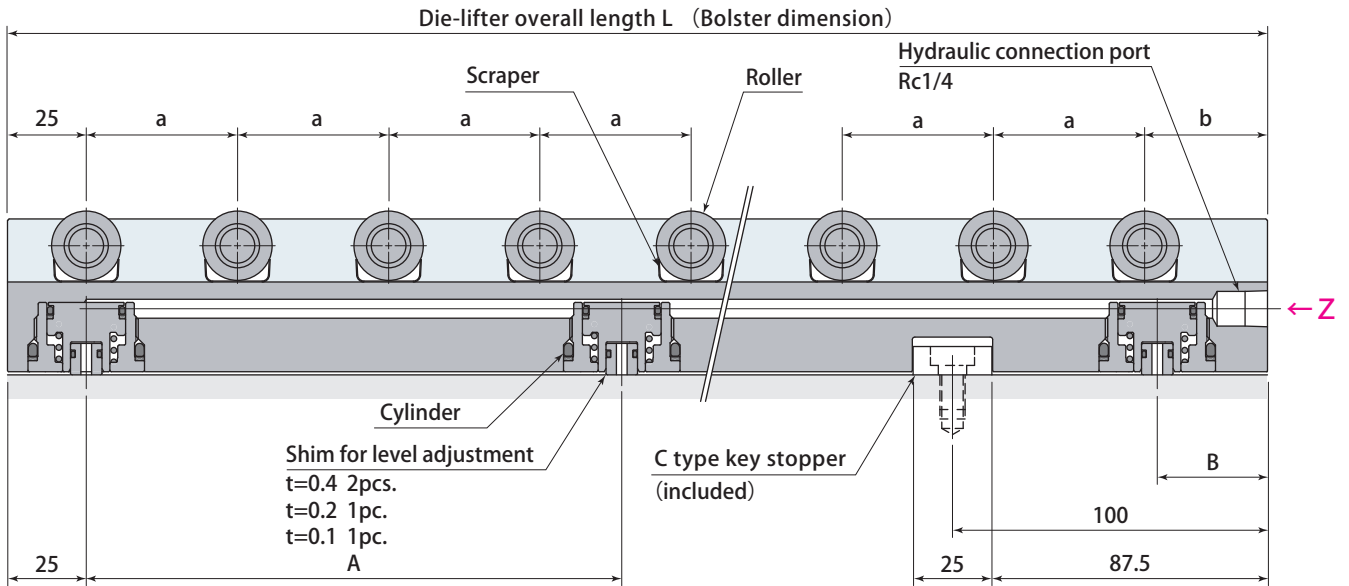

Slot details

VIEW : Z

Die-lifter overall length L	mm	200	225	250	275	300	325	350	375	400
Number of rollers		5	5	6	6	6	7	8	8	8
Max. load per 100 mm	kN	4.65	4.13	4.46	4.06	3.72	4.01	4.25	3.97	3.72
Max. load per overall length *	kN	9.3	9.3	11.2	11.2	11.2	13	14.9	14.9	14.9
Roller pitch	a	mm	35	41	38	43	48	44	45	48
	b	mm	35	36	35	35	35	36	35	39
Number of cylinders		2	2	2	3	3	3	3	3	3
Lifting force per cylinder	kN	24	24	24	36	36	36	36	36	36
Cylinder capacity	cm ³	3	3	3	4.5	4.5	4.5	4.5	4.5	4.5
Cylinder pitch	A	mm	140	165	190	108	120	133	158	170
	B	mm	35	35	35	34	35	34	35	35
Weight	kg	3.2	3.6	4	4.4	4.8	5.2	5.6	6	6.4
Key stopper mount screw		2-M8 length14								

● Max. hydraulic pressure : 24.5 MPa ● Lifting force is under hydraulic force at 24.5 MPa. ● Proof pressure : 36.7 MPa

● Operating temperature : 0 ~ 70°C

* The value indicates Max. load when all of rollers are in contact with the die.

Die-lifter DLF
Scrap hole type

Long lifting stroke type

Model designation

DLF 50 Y 0500 — Drawing No.

- 1** Die-lifter width
 - 2** Y: Standard H: Heavy load
 - 3** Die-lifter overall length (mm)
* Indicated in 4 digits
- For the long lift specifications, drawing No. is added at the end of model No.
- 1 2 3** Refer to pages → 115 ~ 116

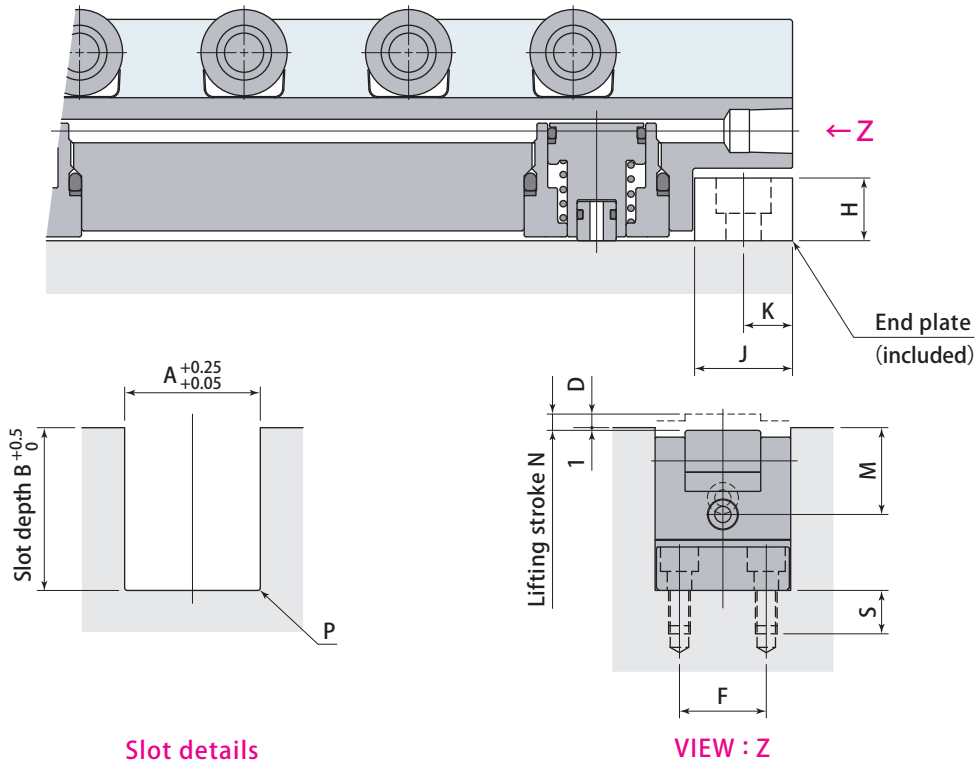

Slot details

VIEW : Z

2-oil connection port is provided when the overall length is 1000mm and over and lift stroke at 12mm and over .

- 2-oil connection port is provided when the overall length is 1000mm and over and lift stroke at 12mm and over in order to have the lifter up and down evenly.
- Provide flow controls valve for each port as shown in circuit diagram to have the lifter up and down evenly by controlling the speed. The valve to be prepared by the customer.
- Below model is recommended when the flow control valve is prepared by the customer.

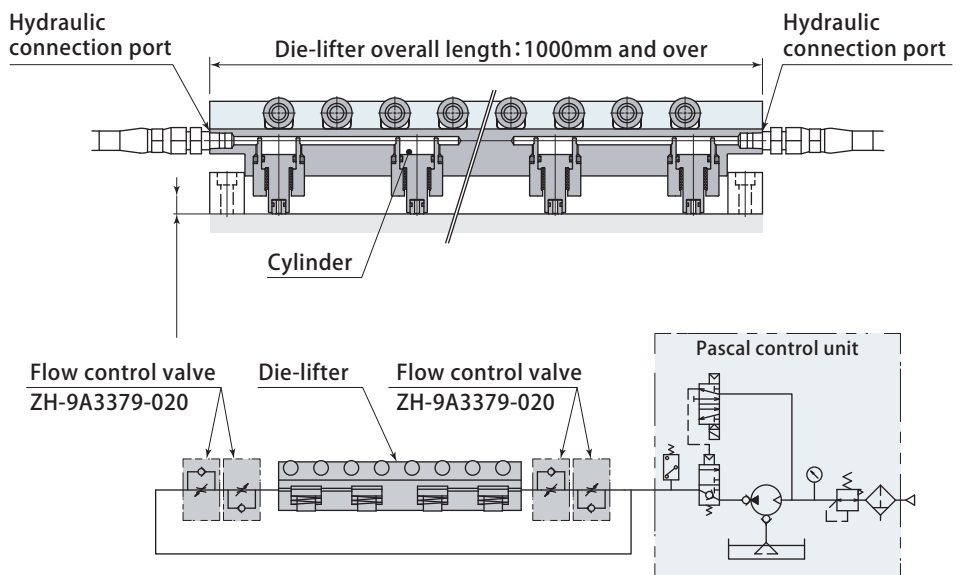

Manufacturer name : Hirose Valve Industry Co., Ltd.
Product Name : Throttle Check Valve
Model : HT - 728 - 02

Sample: Die-lifter circuit diagram with flow control valve

Die-lifter DLF
Long lifting stroke type

● DLF28 Long lifting stroke type Lifting stroke ~ mm mm

Lifting stroke	N	3 (Standard)	6	8	12	16
Slot depth	B	45	52	56	64	73
Roller-level	D	2	5	7	11	15
End plate thickness	H	6	12	19	25	36
End plate mount screw		4-M6 length 10	4-M6 length 16	4-M6 length 22	4-M6 length 30	4-M6 length 35
Thread hole depth	S	10				
	K	8				
	J	16				
	A	28				
	P	Max.R1				
	M	29				
	F	15				

● DLF50 Long lifting stroke type Lifting stroke ~ mm mm

Lifting stroke	N	3 (Standard)	6	8	10	12	16	20
Slot depth	B	53	60	64	73	73	80	89
Roller-level	D	2	5	7	9	11	15	19
End plate thickness	H	9	16	19	30	30	38	38
End plate mount screw		4-M8 length14	4-M8 length20	4-M8 length25	4-M8 length30	4-M8 length30	4-M8 length40	4-M8 length40
Thread hole depth	S	14						
	K	12.5						
	J	25						
	A	50						
	P	Max.R2						
	M	32						
	F	32						

● DLF80 Long lifting stroke type Lifting stroke ~ mm mm

Lifting stroke	N	4 (Standard)	6	12	16
Slot depth	B	80	85	96	109
Roller-level	D	3	5	11	15
End plate thickness	H	16	25	25	45
End plate mount screw		4-M10 length 20	4-M10 length 30	4-M10 length 30	4-M10 length 50
Thread hole depth	S	18			
	K	12.5			
	J	25			
	A	80			
	P	Max.R2			
	M	49			
	F	50			

- If overall length is 1000mm and over, and lifting stroke is 12mm and over, 2 ports piping is applied.
- The cover will be mounted on model DLF with long lifting stroke. DLF50 : 20mm and over , DLF28 : 16mm and over refer to **page→133**.
- Pre-roller is special specifications for aligning the level between Die-lifter and rollers.
- Choose long stroke for Clamp. When Clamp with standard stroke is used, be sure to lift up Die-lifter after Clamp is moved backward.

Model designation

DLF 50 Y 0500 — Drawing No.

- 1 Die-lifter width
 - 2 Y:Standard H:Heavy load
 - 3 Die-lifter overall length (mm)
* Indicated in 4 digits
- 1 2 3 Refer to pages → 115 ~ 116

For roller cover type, Heat proof type, Special cylinder position and Special number of rollers, the drawing No. is added at the end of model No.

Roller cover Cover is attached on the upper surface of Die-lifter and it prevents scrap intrusion to the rollers.

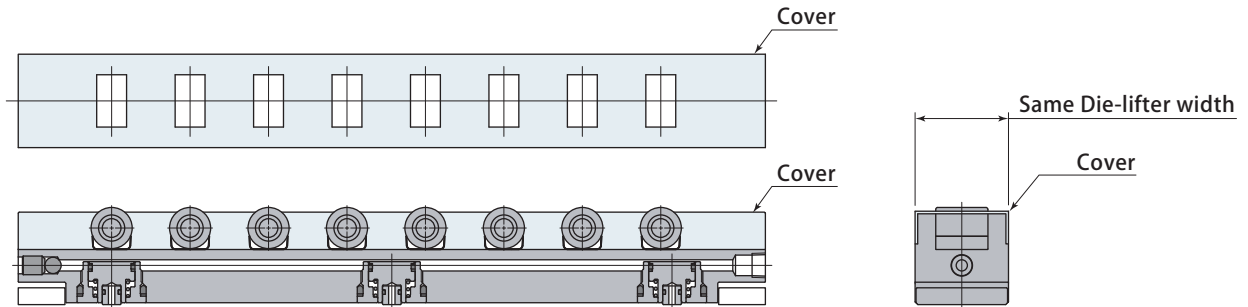

- The cover shall be equipped with the DLF for the following model and stroke.
DLF50: stroke more than 20mm
DLF28: stroke more than 16mm

Heat proof type It is applied under condition that the die and its surroundings are in high temperature.

- The operating temperature of heat proof type is 5-120°C.

Special cylinder position

In case that Die-lifter shot has cushion pin hole, the cylinder positioning shall be special.

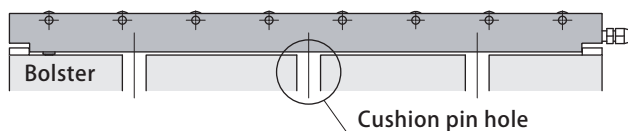

- Indicate the shape and size of bolster. Contact Pascal for the details.

Special number of rollers

In case that the die has cutouts, number of rollers shall be special.

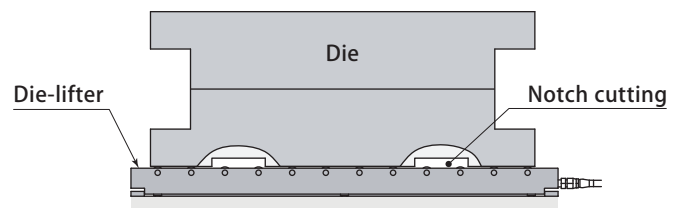

- Indicate the shape and size of the bottom surface of die. Contact Pascal for the details.



Die-roller model **DRA**

Die-roller



Die-roller **DRA**

A spring lifting roller that does not need hydraulic source.
The compact design allows an easy installation just to slot it in the machine T-slots.

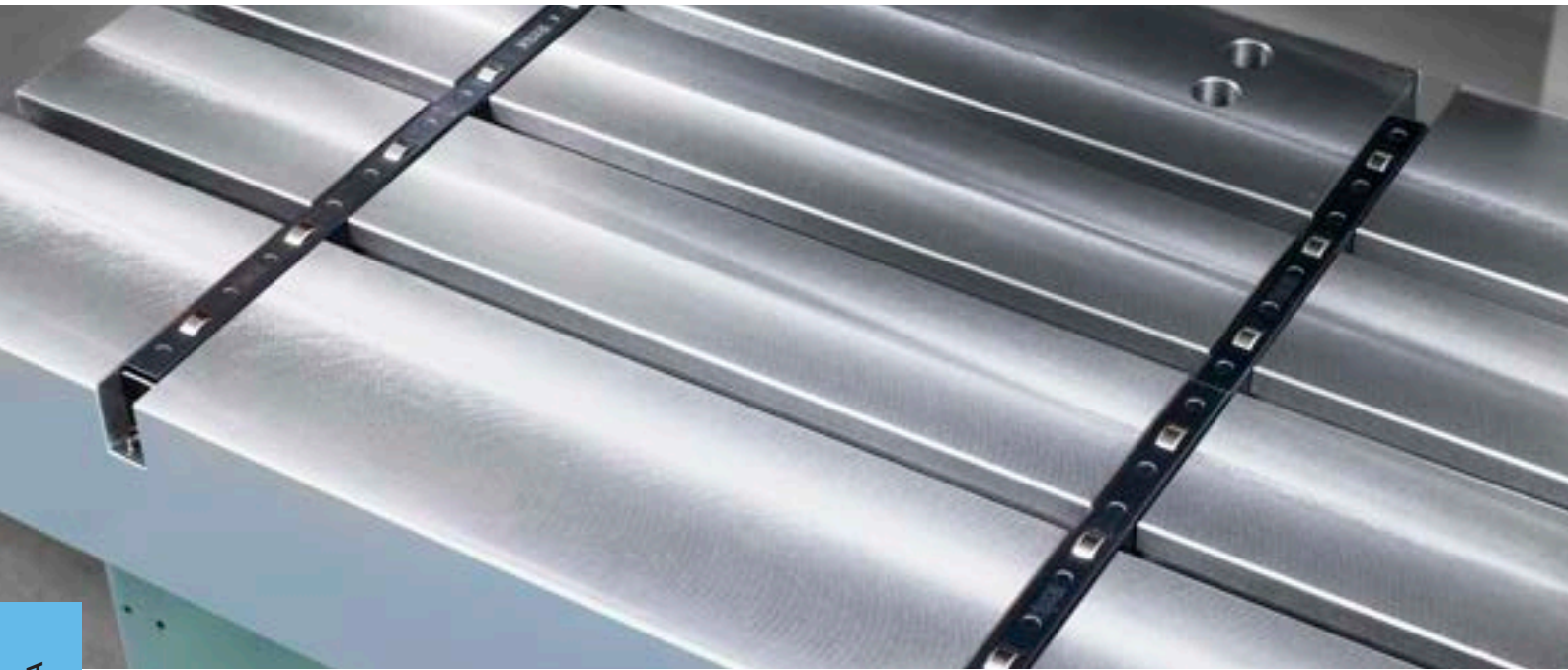

Model designation

DRA **30** - **200** - **28**

- 1** Die-roller width
DRA **18** : 18 mm
DRA **20** : 20, 22, 24 mm
DRA **30** : 28, 32, 36 mm
- 2** Length of 1 piece
200 : 200 mm
300 : 300 mm
- 3** T/U-slot dimension a(mm)



Any length of the rollers with 100 mm pitch can be composed by combination of 200mm and 300mm die-lifting rollers.

3 T/U-slot

Model	DRA18	DRA20	DRA30
3 a mm	18	20 (Standard), 22, 24	28 (Standard), 32, 36
k mm	32 ~ 43		44 ~ 58

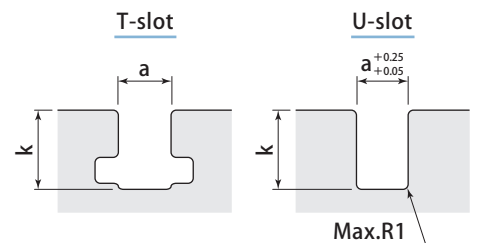

- Adjust roller-top level by height adjustment bolts to meet T/U-slot depth (Max. lifting stroke 2mm).

Specifications

Model		DRA18	DRA20	DRA30	
Lifting force per 100 mm (1 line)		kN	0.588	0.735	1.47
Weight per roller	DRA□-200-□ (Length 200mm)	kg	0.31	0.36	0.75
	DRA□-300-□ (Length 300mm)	kg	0.46	0.53	1.13
Lifting force per height adjustment bolt		kN	0.294	0.367	0.735

- Operating temperature : 0 ~ 110°C
- Select requested total length in combinations of 200 mm and 300 mm die-lifting rollers.
- Lock the height adjustment bolts with lock nuts after adjusting height.
- Lifting force can be reduced by removing the height adjustment bolts. The bolts at both ends of the die-lifting rollers should not be removed.

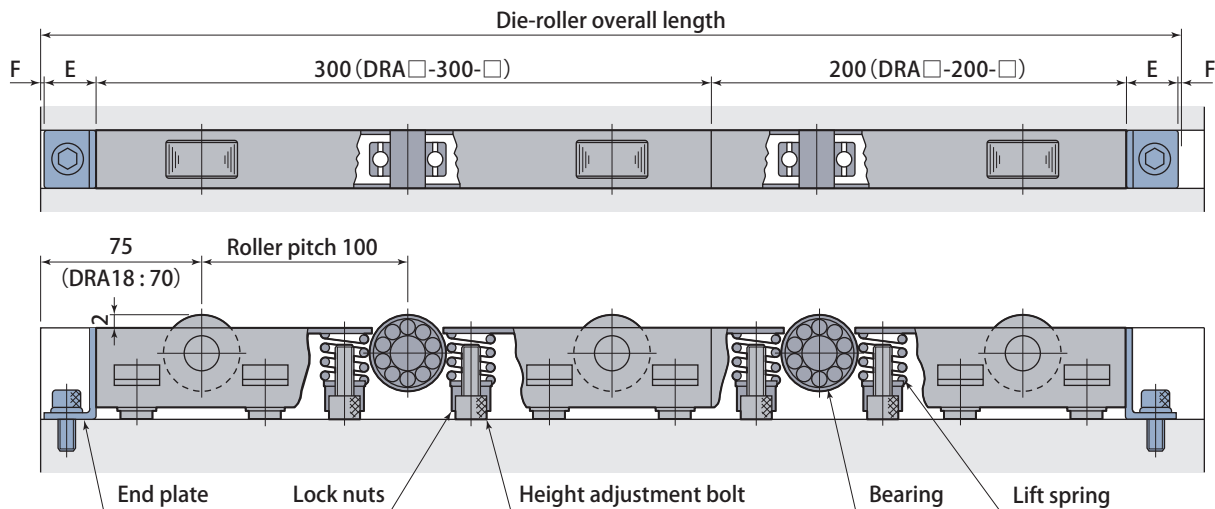

mm			
Model	DRA18	DRA20	DRA30
E	19	23	23
F	1	2	2

End plate (L stopper)

DRL-18 L ••••• K Dimension L: Low distance clamp type H: Upper distance clamp type

T/U-slot dimension a : 18~36 (mm)

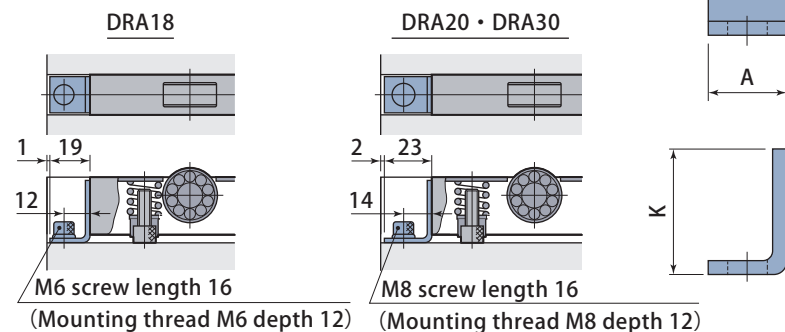

Model		T/U-slot dimension a	A	K
DRL-18	L	18	17	32
	H			43
DRL-20	L	20	19	32
	H			43
DRL-22	H	22	21	43
DRL-24	H	24	23	43
DRL-28	L	28	27	45
	H			58
DRL-32	H	32	31	58
DRL-36	H	36	35	63

● Cut the end plate 0.5 mm shorter than the depth of the T/U-slot.

Maximum lifting force per pair rollers

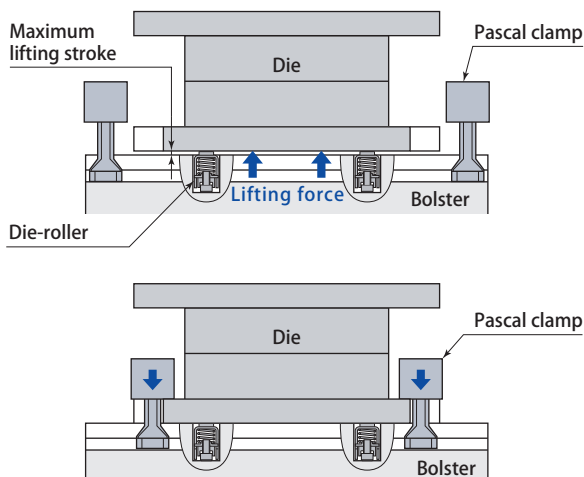

Die rollers are pressed down into bolster by clamping force.

* Overall length mm	Model		
	DRA18	DRA20	DRA30
250	2.35	2.94	5.88
350	3.53	4.41	8.82
450	4.70	5.88	11.7
550	5.88	7.35	14.7
650	7.06	8.82	17.6
750	8.23	10.2	20.5
850	9.41	11.7	23.5
950	10.5	13.2	26.4
1050	11.7	14.7	29.2
1150	12.9	16.1	32.3
1250	14.1	17.6	35.3
1350	15.2	19.1	38.2
1450	16.4	20.5	41.1
1550	17.6	22.0	44.1

* Overall length of model DRA18 is 10mm shorter than above lengths.

Pre-roller

model **PR**



Removable & fold type

model **PRA**

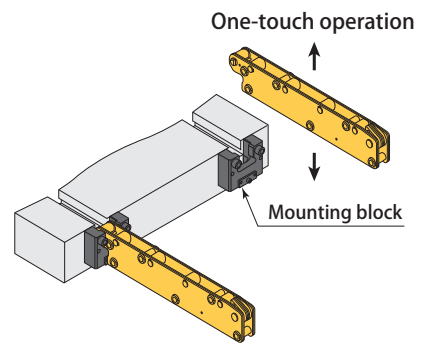

page → 143

model **PRF**

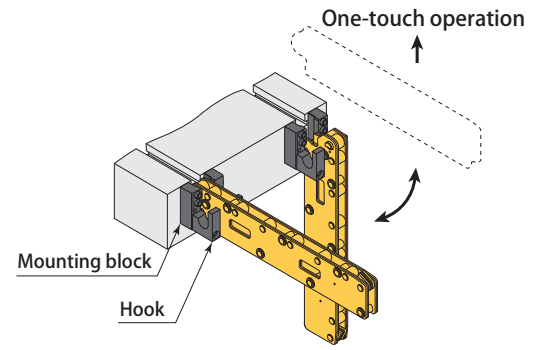

page → 155



Horizontally fold type

model **PRS** / model **PRT**

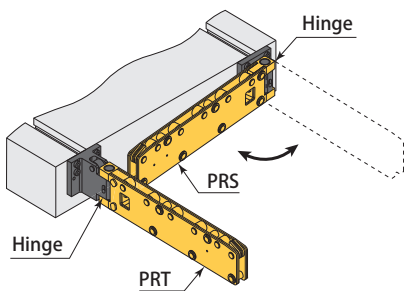

Heavy load type

model **PRC**

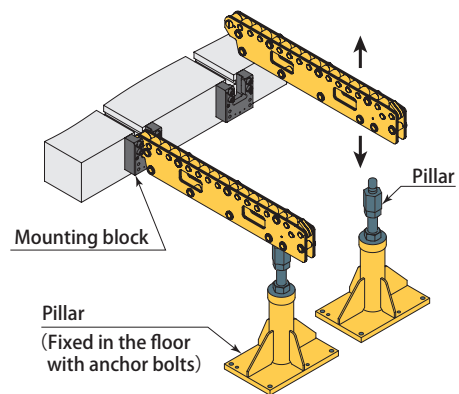

* The bending position is different between S and T.
Refer to page → 167 for the details.

page → 179

Model designation

PR **A** **3** - **0630** B

- 1** Model
- 2** Size
- 3** Die travel (mm) * Indicated in 4 digits

1 Model

A	F	S / T	C
(Standard)	Removable & fold type	Horizontally fold type	Heavy load type
page → 143	page → 155	page → 167	page → 179

2 Size

PRA			PRF			PRS / T			PRC	
2	3	5	2	3	5	3	5	8	3	5

3 Die travel

Die travel

Die travel = Length from bolster edge to the stopper.

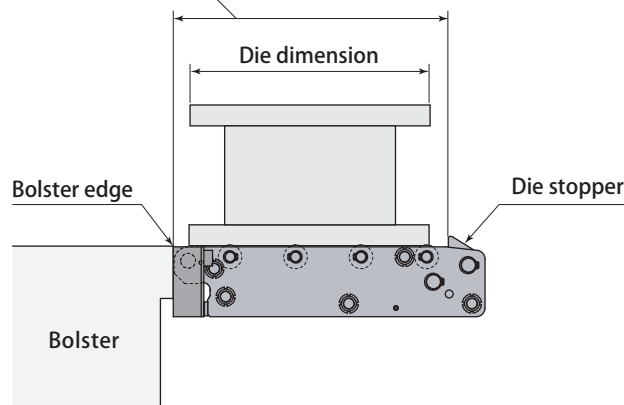

● Select the Pre-roller where die dimensions are within die travel.

Selection of Pre-roller

Selection of Pre-roller each for allowable load (Die weight)

In case the die weight is 5 tons, select PRA5-0400B or PRF5-0400B or PRS8-0630B/PRT8-0630B or PRC3-0950B.

mm

Allowable load * (Die weight)	PRA2	PRA3	PRA5	PRF2	PRF3	PRF5	PRS3 PRT3	PRS5 PRT5	PRS8 PRT8	PRC3	PRC5
	Die travel										
8 tonf (80kN)											
7 tonf (70kN)											1250
6 tonf (60kN)										800	
5 tonf (50kN)			400			400			630	950	
4 tonf (40kN)			450			450			710	1000	
3.2 tonf (32kN)		355	560		355	560	355	630	900		
2.6 tonf (26kN)		400	710		400	710	450	710	1000		
2 tonf (20kN)		450	850		450	850	500	850			
1.6 tonf (16kN)	250	630	1000	250	630	1000	630	950			
1.2 tonf (12kN)		710			710		710	1000			
1 tonf (10kN)	355	850		355	850						
0.8 tonf (8kN)	450	950		450	950						
0.6 tonf (6kN)	500	1000		500	1000						
0.5 tonf (5kN)	630			630							

Pre-roller Selection

* The allowable load of above table is for 2 pre-rollers.

Allowable load

- Select Pre-roller where allowable load (kN) multiplied by the quantity is greater than the die weight.
SI conversion : Die weight (kN)=Die weight (kgf)×9.8÷1000

Allowable load of

PRA
PRF
PRS
PRT

Static load measured at the position of 1/4 of the die travel

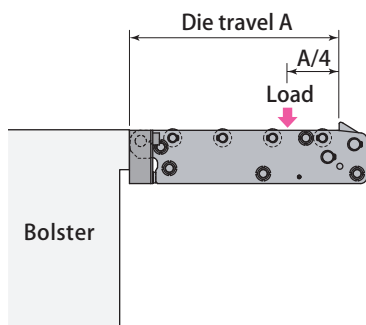

Allowable load of

PRC

Uniformly distributed and held by the middle part of the Pre-roller

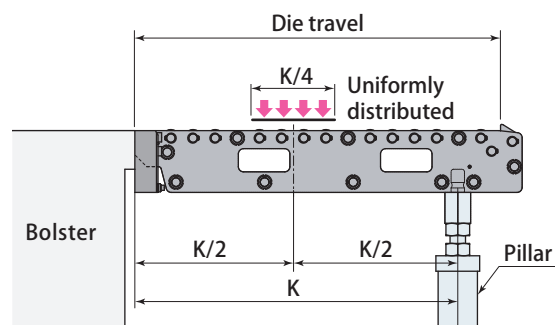

Detachable type Pre-roller

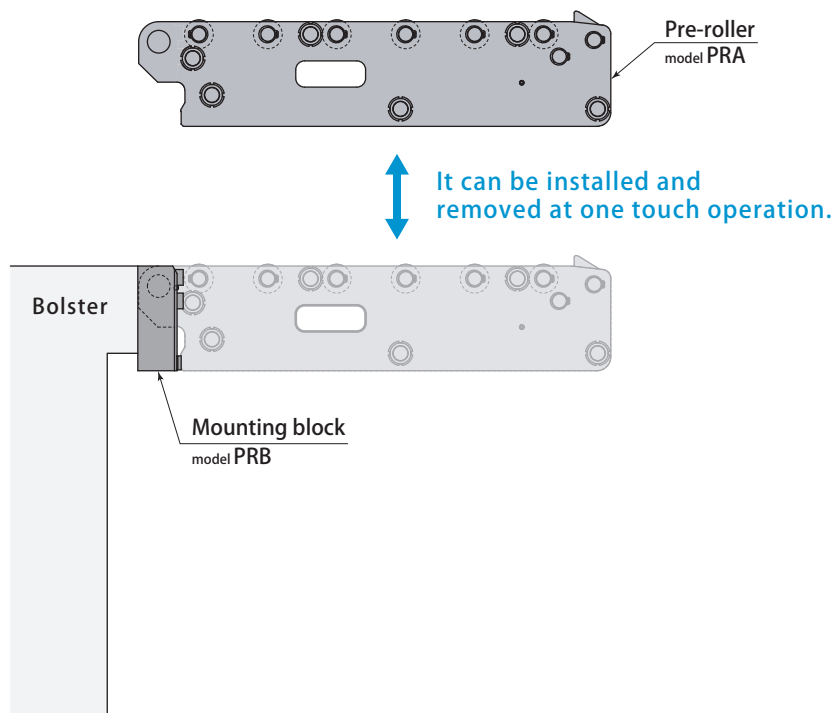

- The Pre-roller may be damaged due to the vibration through stamping operation. The removal of pre-roller during the operation is recommended.
- Be noted that the specifications of Mounting block PRB and PRB□F(mounting block for PRF) are different.

Model designation

Set model (Pre-roller + Mounting block)

PRA **2** - **0200** B - S

Size
PRA2 PRA3 PRA5

1 Die travel (mm)
* Indicated in 4digits

For set model, S is added
at the end of model No.

Pre-roller model type

PRA **2** - **0200** B

Size
PRA2 PRA3 PRA5

1 Die travel (mm) * Indicated in 4 digits

Mounting block model type

PRB **2**

Size
PRB2 PRB3 PRB5

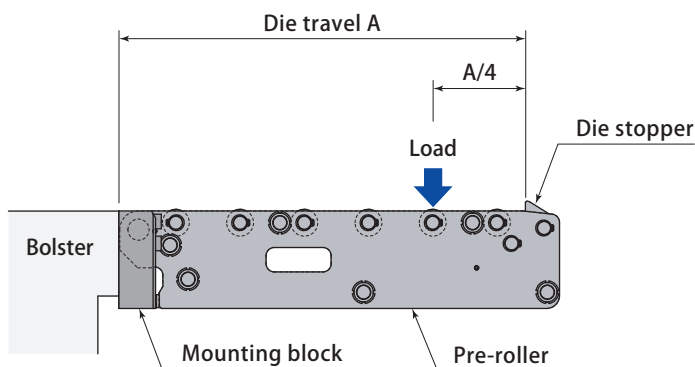

1 Die travel **200** ~ **1000** mm

Die travel		mm	200	250	315	355	400	450	500	560	630	710	800	850	900	950	1000
PRA2	Allowable load *	kN	8	8	5	5	4	4	3	2.5	2.5	—	—	—	—	—	—
	Number of rollers		3	4	4	5	5	6	6	7	7	—	—	—	—	—	—
	Weight	kg	3.1	3.7	4.2	4.7	5.1	5.5	5.9	6.6	7.2	—	—	—	—	—	—
PRA3	Allowable load	kN	—	—	16	16	13	10	8	8	8	6	5	5	4	4	3
	Number of rollers		—	—	4	4	5	5	6	6	7	7	7	8	8	8	9
	Weight	kg	—	—	7.6	8.4	9.5	10	11.1	12.1	13.4	14.7	16.3	17.4	18.4	19.2	20.3
PRA5	Allowable load	kN	—	—	—	—	25	20	16	16	13	13	10	10	8	8	8
	Number of rollers		—	—	—	—	4	5	5	6	6	7	7	8	8	9	9
	Weight	kg	—	—	—	—	10.4	11.4	12.2	13.6	15.1	16.9	18.1	19.2	20.1	21.5	22.5

● Die loading speed on Pre-roller : Less than 50mm/s ● Die transfer speed : Less than 100mm/s ● Weight does not include mounting block.
* Allowable load is a static load measured at the position of 1/4 of the die travel from the stopper. Select Pre-roller where allowable load (kN) multiplied by the quantity is greater than the die weight. SI conversion : Die weight (kN)=Die weight (kgf)×9.8÷1000

Dimensions

PRA 2 – 0200 B – S

1 Die travel (mm)
* Indicated in 4 digits

1 Die travel 200 ~ 630 mm

Model	PRA2-0200B	PRA2-0250B	PRA2-0315B	PRA2-0355B	PRA2-0400B	PRA2-0450B	PRA2-0500B	PRA2-0560B	PRA2-0630B
Die travel	mm 200	250	315	355	400	450	500	560	630
Pre-roller total length	mm 242	292	357	397	442	492	542	602	672
Weight	kg 3.1	3.7	4.2	4.7	5.1	5.5	5.9	6.6	7.2

PRA2-0200B-S

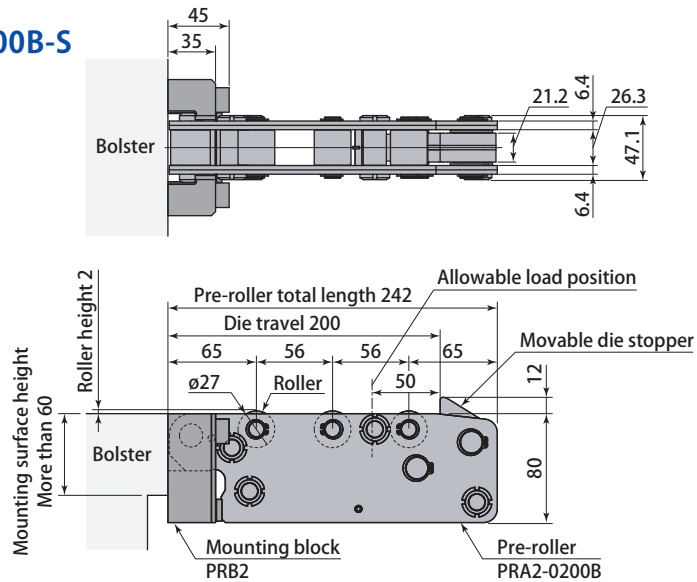

PRA2-0250B-S

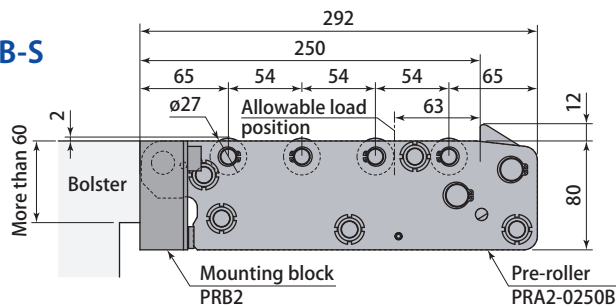

PRA2-0315B-S

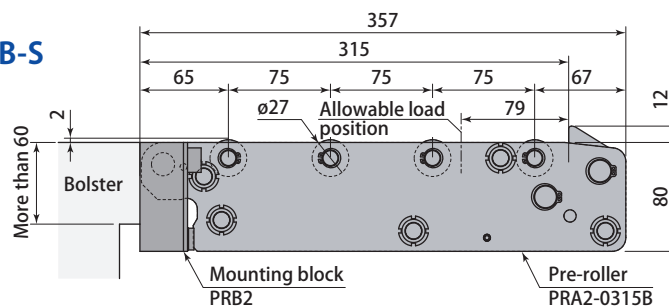

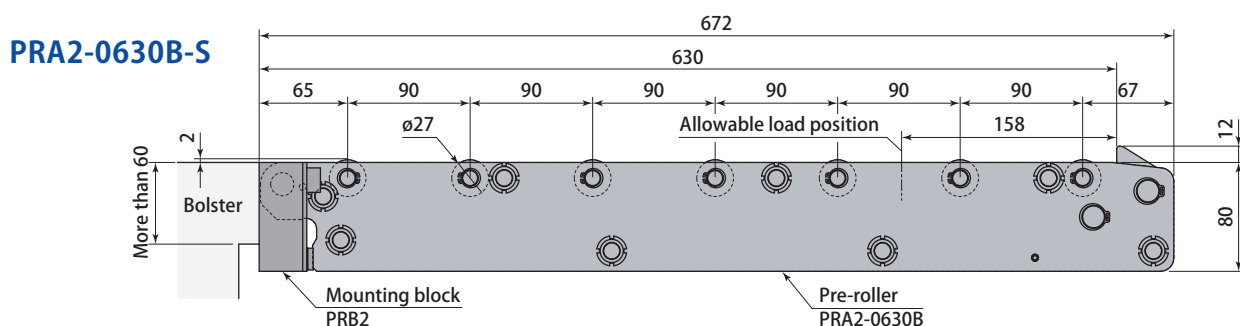
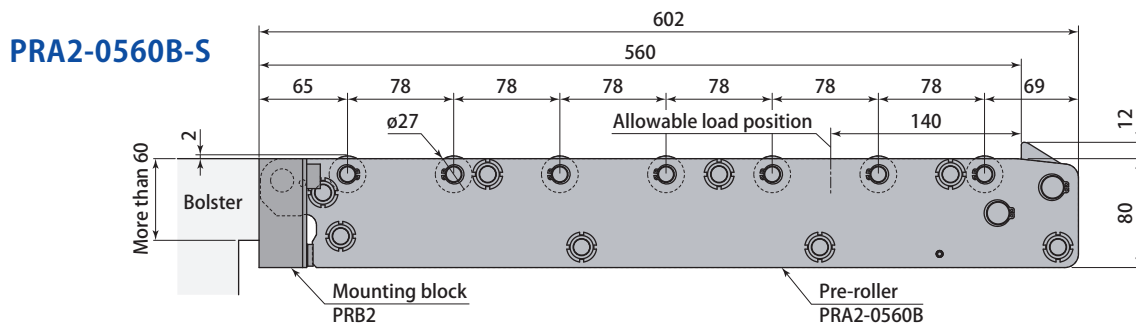
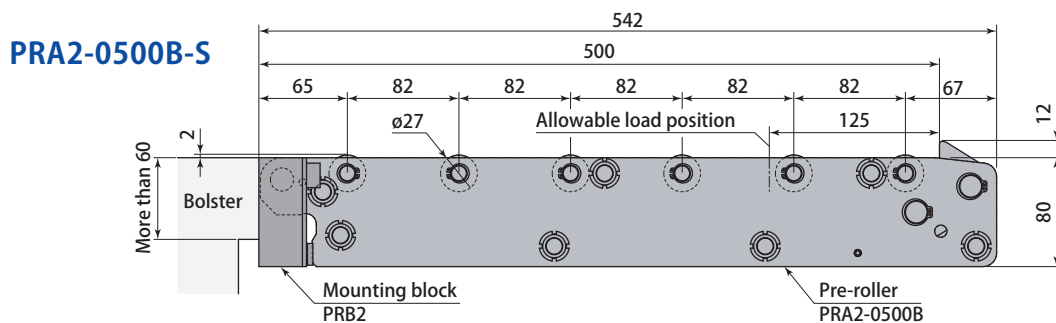
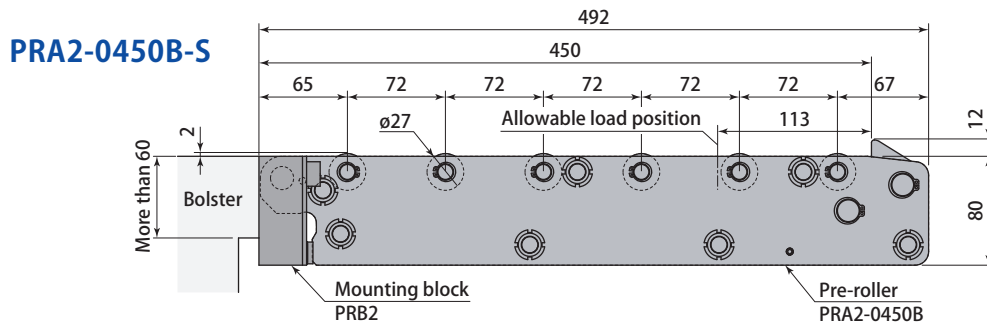
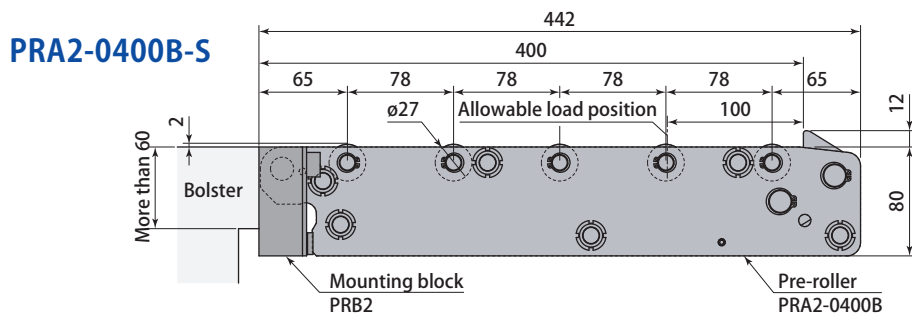
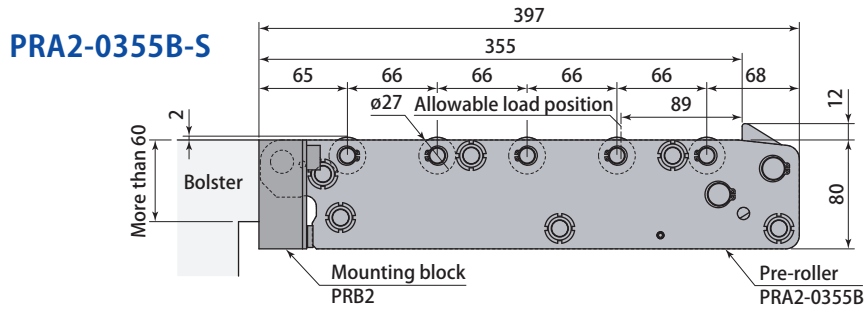

Dimensions

PRA 3 – 0315 B – S

1 Die travel (mm)
* Indicated in 4 digits

1 Die travel 315 ~ 1000 mm

Model	PRA3-0315B	PRA3-0355B	PRA3-0400B	PRA3-0450B	PRA3-0500B	PRA3-0560B	PRA3-0630B	PRA3-0710B	PRA3-0800B	PRA3-0850B	PRA3-0900B	PRA3-0950B	PRA3-1000B
Die travel	mm 315	355	400	450	500	560	630	710	800	850	900	950	1000
Pre-roller total length	mm 357	397	442	492	542	602	672	752	842	892	942	992	1042
Weight	kg 7.6	8.4	9.5	10	11.1	12.1	13.4	14.7	16.3	17.4	18.4	19.2	20.3

PRA3-0315B-S

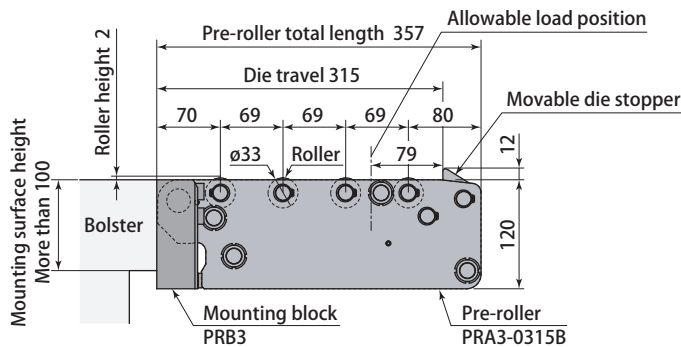
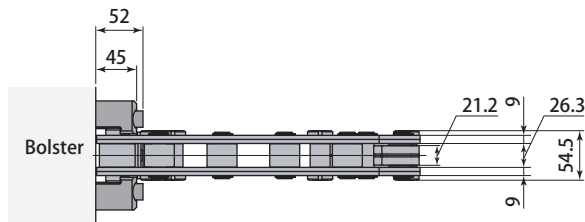

PRA3-0355B-S

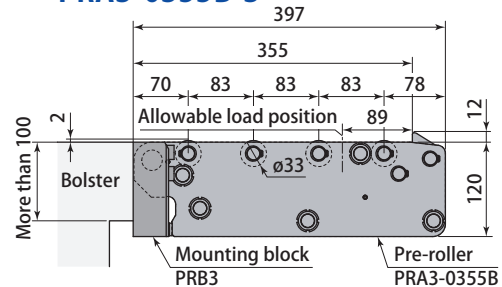

PRA3-0400B-S

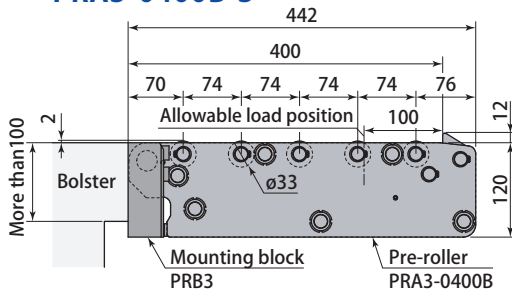

PRA3-0450B-S

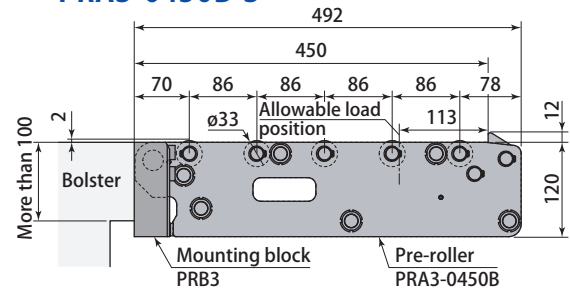

PRA3-0500B-S

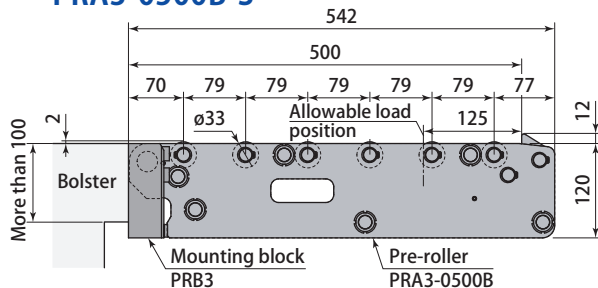

PRA3-0560B-S

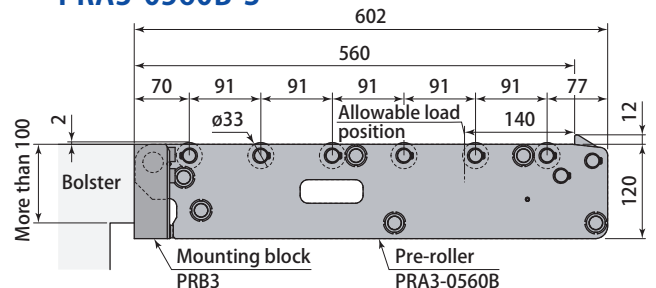

PRA3-0630B-S

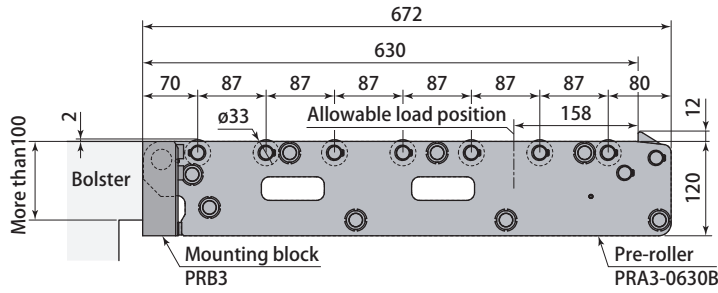

PRA3-0710B-S

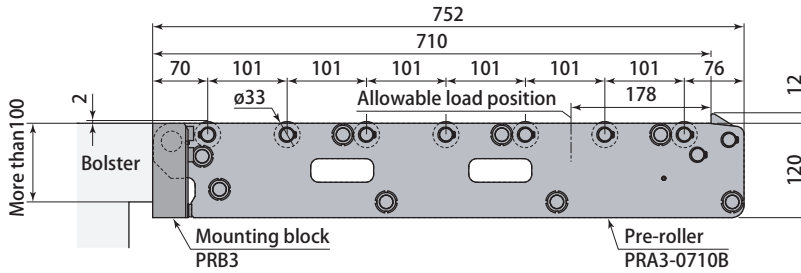

PRA3-0800B-S

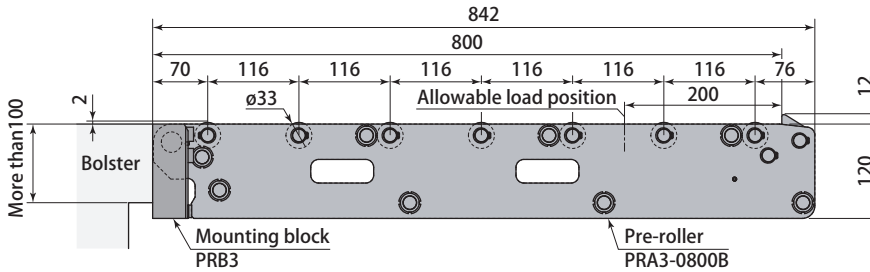

PRA3-0850B-S

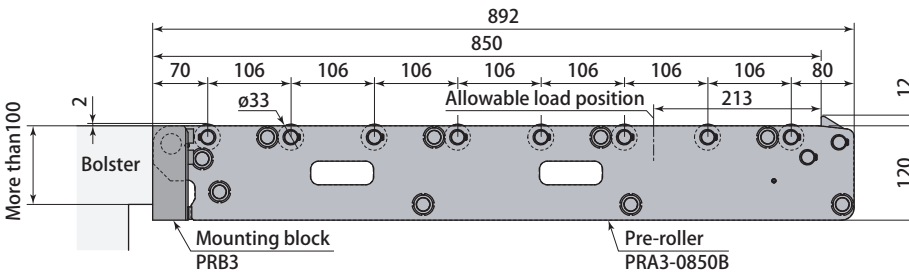

PRA3-0900B-S

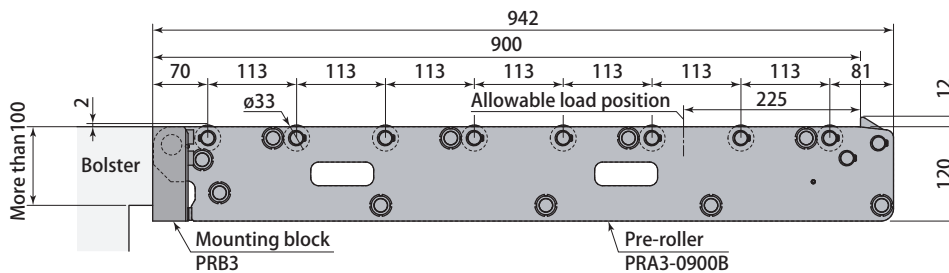

PRA3-0950B-S

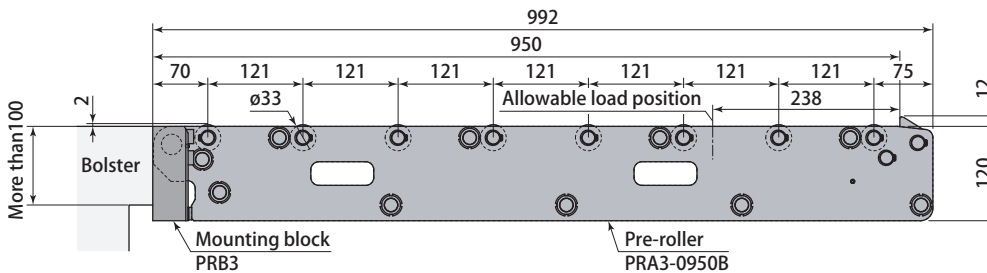

PRA3-1000B-S

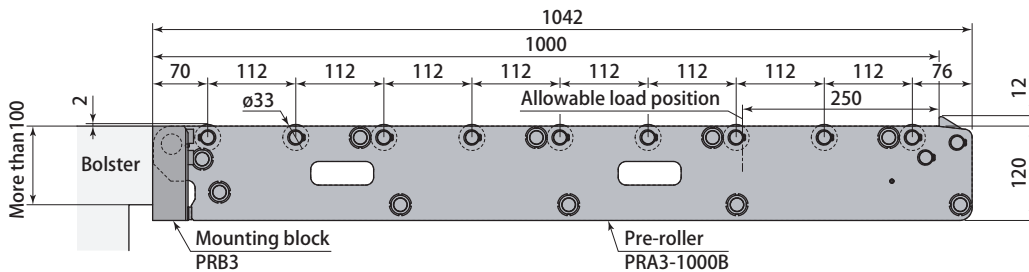

Dimensions

PRA 5 - 0400 B - S

1 Die travel (mm)

* Indicated in 4 digits

1 Die travel 400 ~ 1000 mm

Model	PRA5-0400B	PRA5-0450B	PRA5-0500B	PRA5-0560B	PRA5-0630B	PRA5-0710B	PRA5-0800B	PRA5-0850B	PRA5-0900B	PRA5-0950B	PRA5-1000B
Die travel	mm 400	450	500	560	630	710	800	850	900	950	1000
Pre-roller total length	mm 450	500	550	610	680	760	850	900	950	1000	1050
Weight	kg 10.4	11.4	12.2	13.6	15.1	16.9	18.1	19.2	20.1	21.5	22.5

PRA5-0400B-S

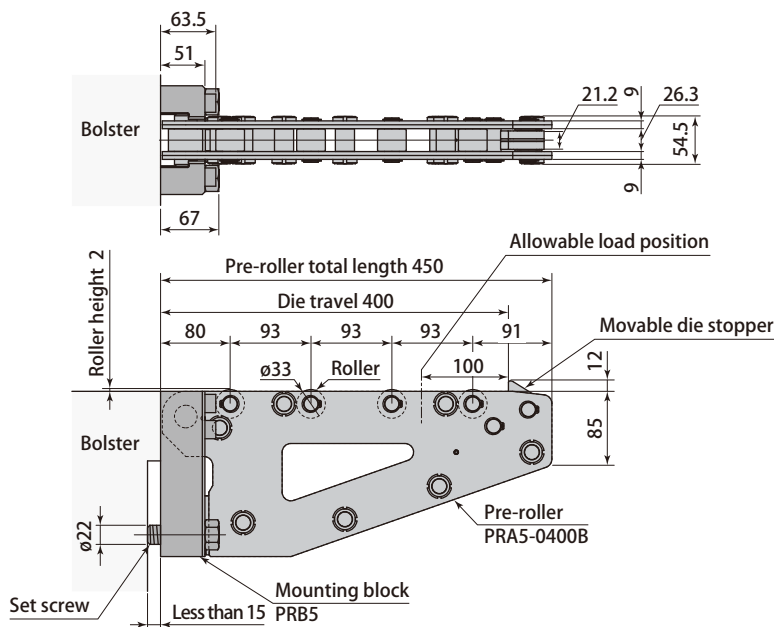

PRA5-0450B-S

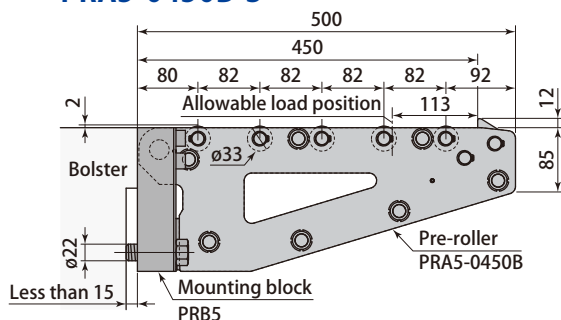

PRA5-0500B-S

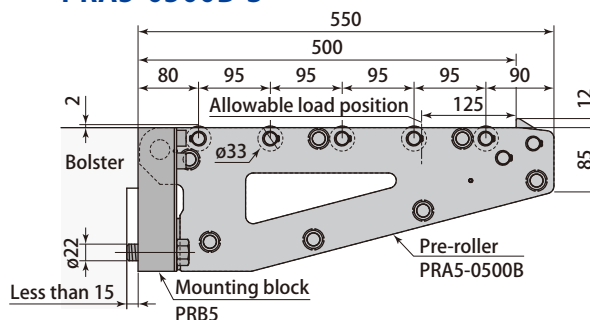

PRA5-0560B-S

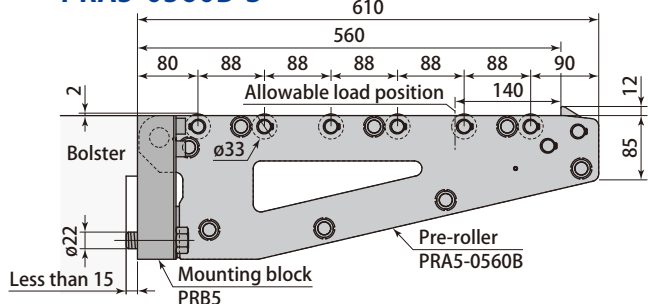

PRA5-0630B-S

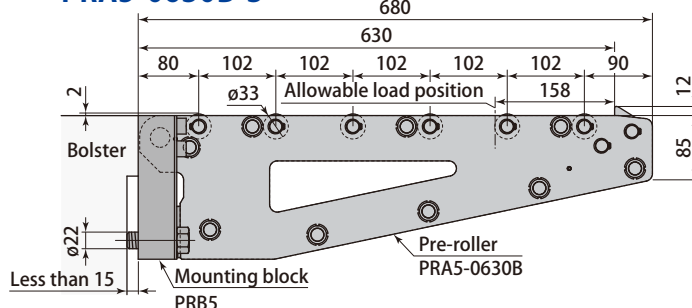

PRA5-0710B-S

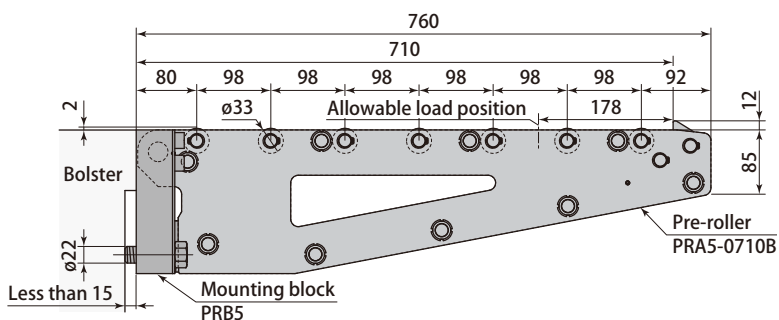

PRA5-0800B-S

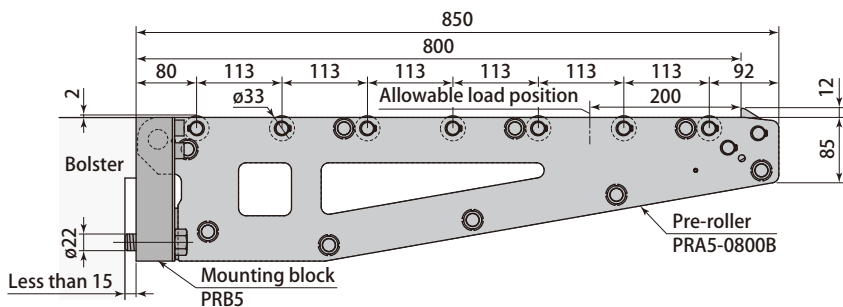

PRA5-0850B-S

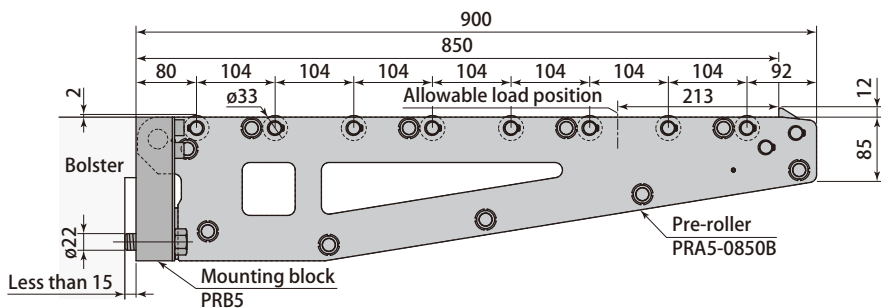

PRA5-0900B-S

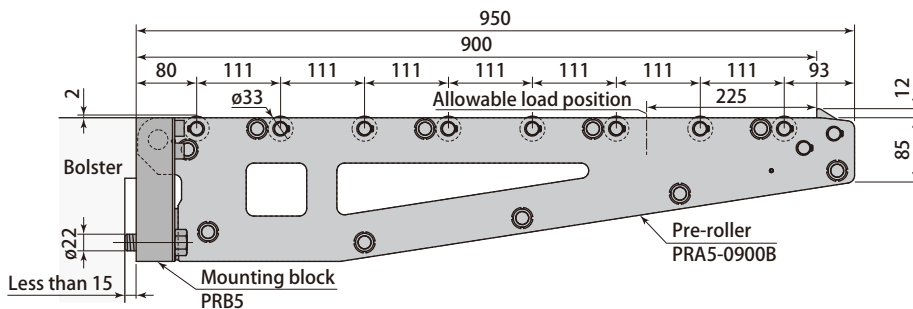

PRA5-0950B-S

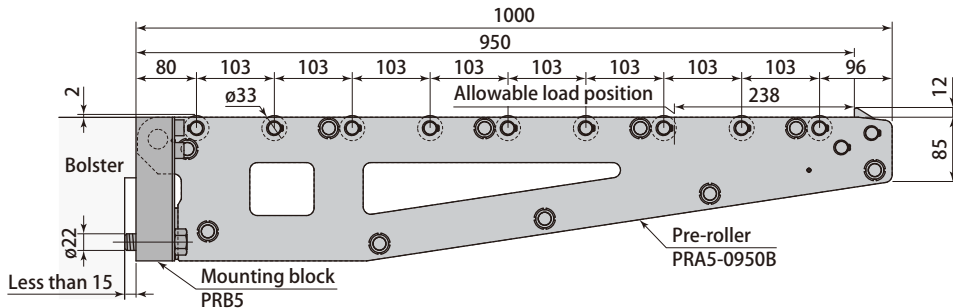

PRA5-1000B-S

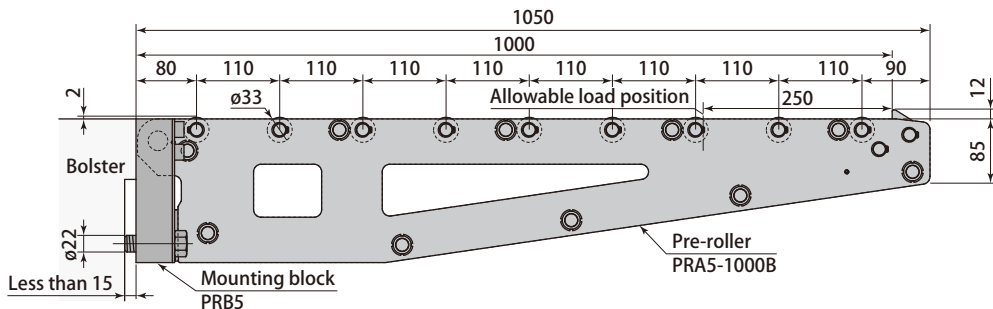

Dimensions, Mounting details

● When using the Die-lifter

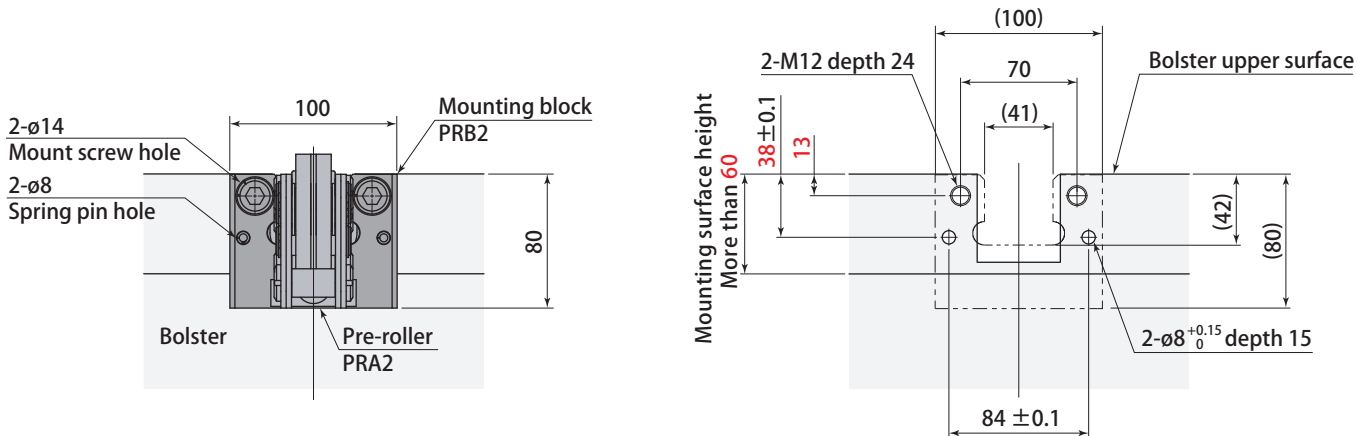

● When not using the Die-lifter

When aligning the level between roller top and bolster surface.

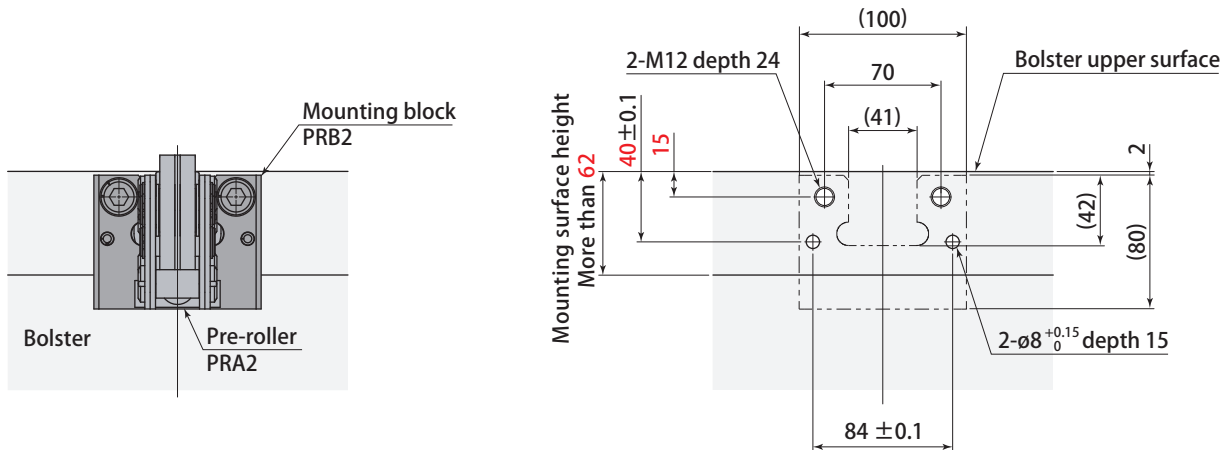

- When machining the spring pin hole, keep the tolerances shown above.
- Drill dia 8mm, 15mm deep hole for spring pin when co-machining the block with mount face.

Model		PRB2
Weight	kg	1.5
Mount screw		2-M12 length 55
Spring washer		2-M12
Spring pin		2-ø8 length 45

● Mounting block for PRA2

Dimensions, Mounting details

● When using the Die-lifter

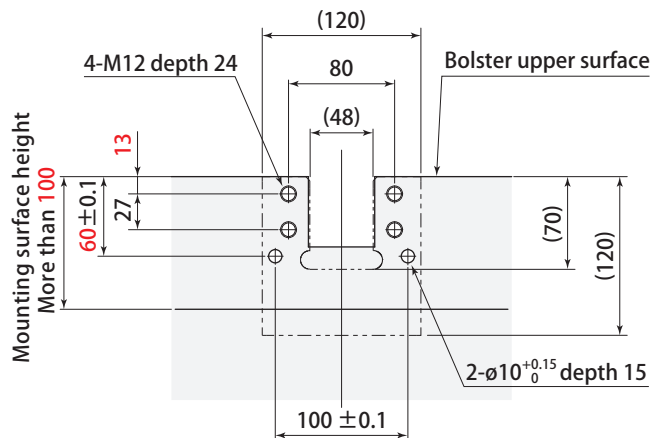
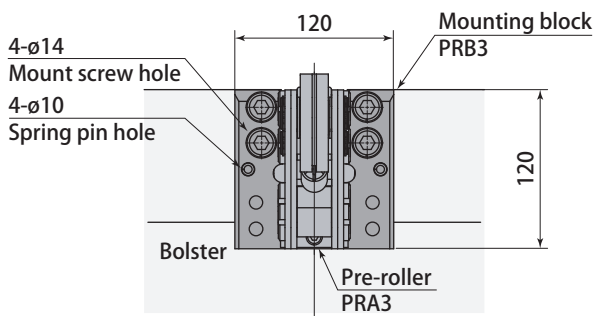

● When not using the Die-lifter

When aligning the level between roller top and bolster surface.

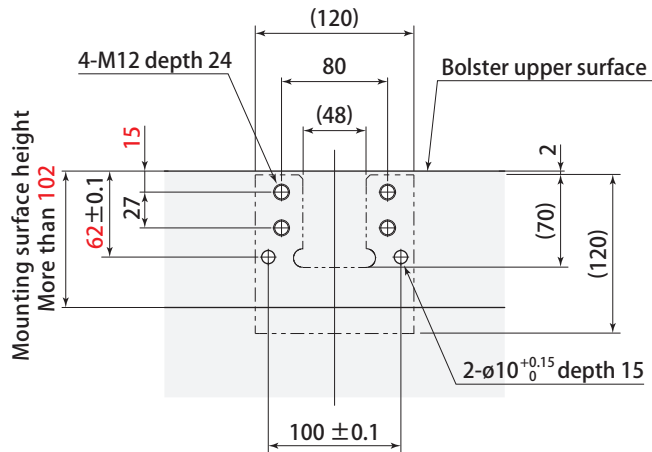
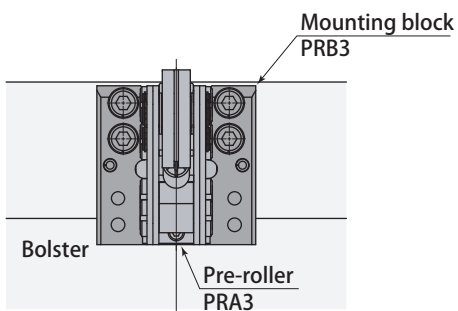

- When machining the spring pin hole, keep the tolerances shown above.
- Drill dia 10mm, 15mm deep hole for spring pin when co-machining the block with mount face.

Model		PRB3
Weight	kg	3.6
Mount screw		4-M12 length 60
Spring washer		4-M12
Spring pin		2-ø10 length 56

● Mounting block for PRA3

Dimensions, Mounting details

● When using the Die-lifter

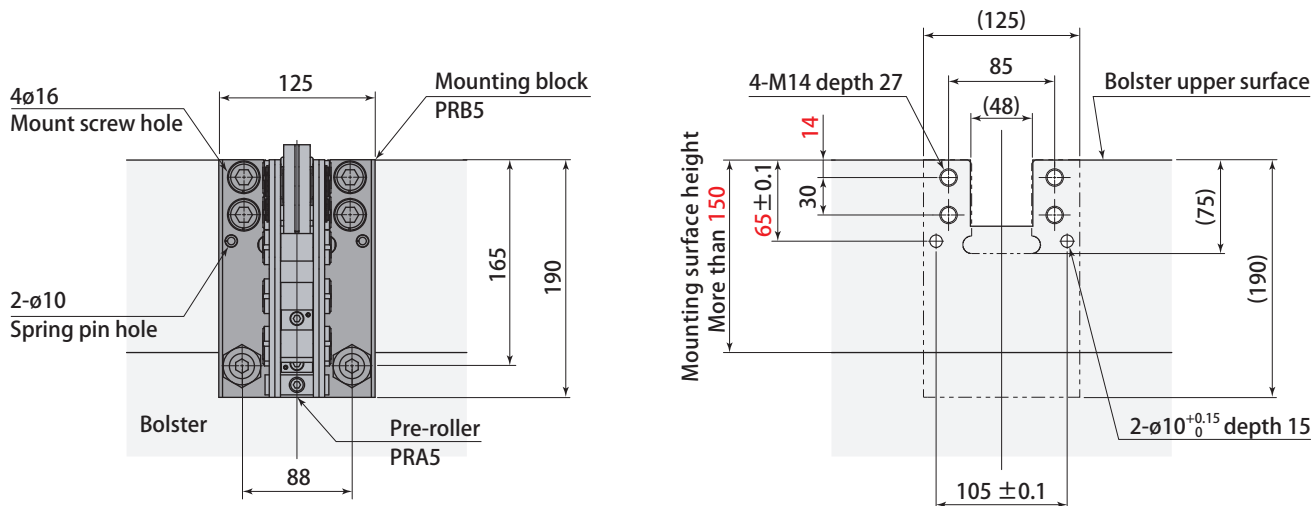

● When not using the Die-lifter

When aligning the level between roller top and bolster surface.

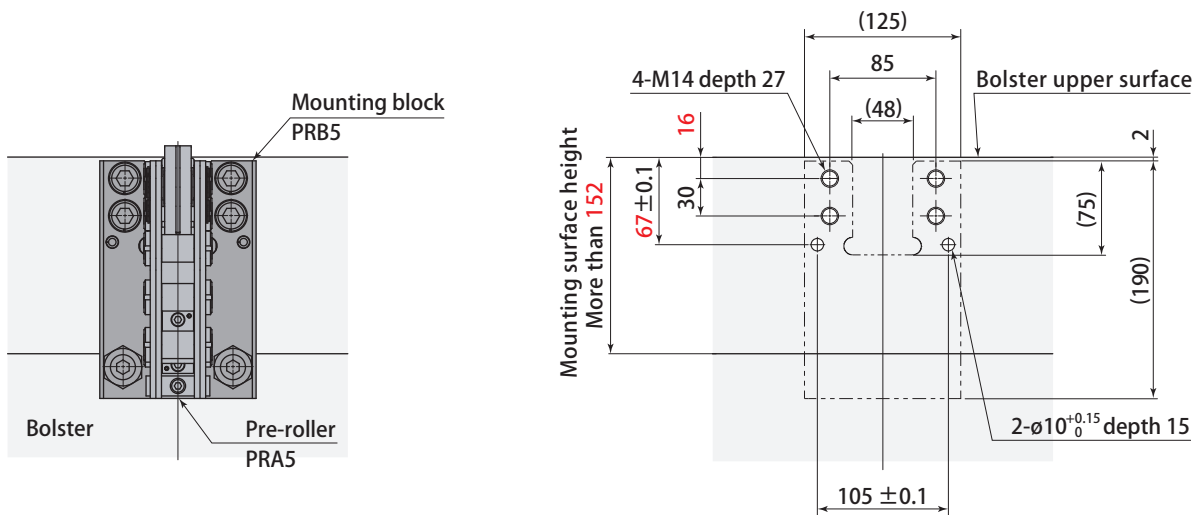

- When machining the spring pin hole, keep with the tolerances shown above.
- Drill dia 10mm, 15mm deep hole for spring pin when co-machining the block with mount face.

Model		PRB5
Weight	kg	7.5
Mount screw		4-M14 length 75
Spring washer		4-M14
Spring pin		2-ø10 length 63

● Mounting block for PRA5

Set screw (only PRA5)

● Set screw presence

Model	PRA2	PRA3	PRA5
Set screw	Not included	Not included	Included

Model	PRA5	
Mounting surface height	80mm ~ 150mm	More than 150mm
Use of set screw	Required	Not required

- The set screw is used to prevent the inclination of pre-roller, in case that the mounting surface height is short.

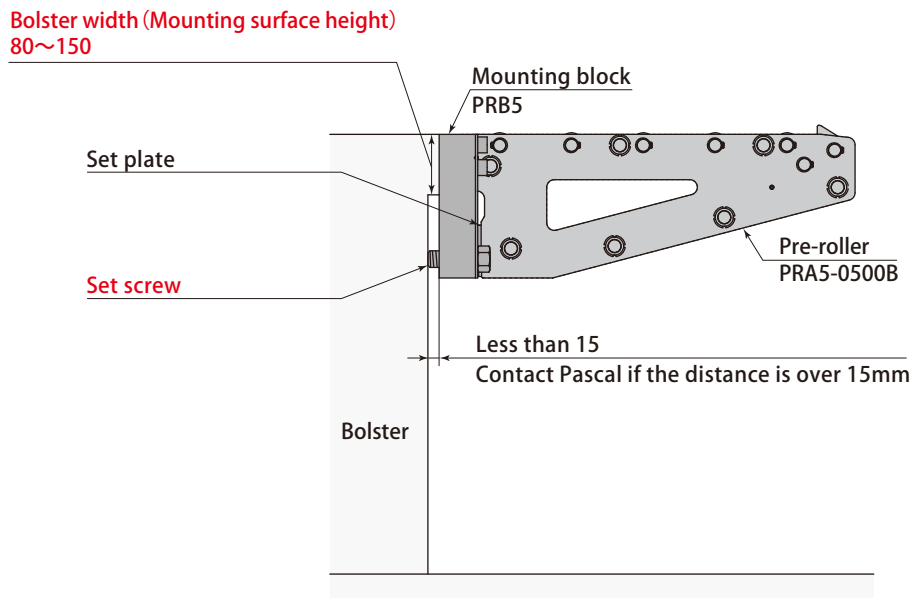

* This drawing indicates PRA5-0500B-S.

It is the pre-roller installed with fold to removable type PRA.



At installation

At removal

At hanging

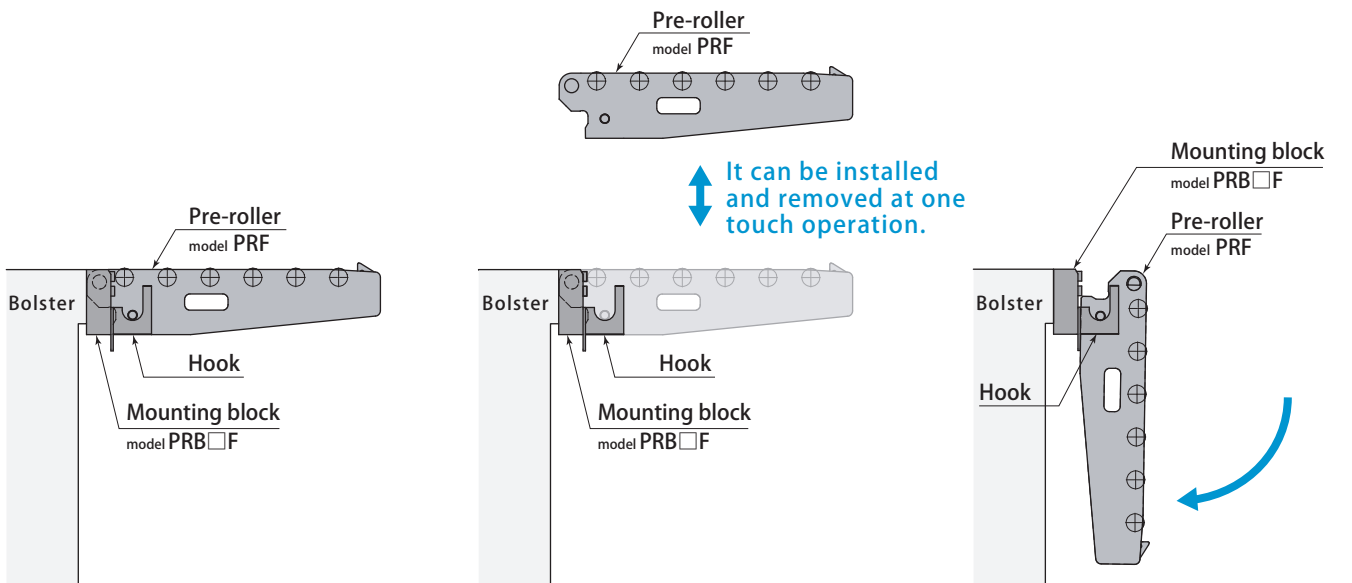

- Be noted that the specifications of Mounting block PRB and PRB□F (mounting block for PRA) are different.
- Pull down the pre-roller slowly at folding.

Model designation

Set model (Pre-roller + Mounting block)

PRF 2 - 0200 B - S

Size
PRF2 PRF3 PRF5

1 Die travel (mm)
* Indicated in 4 digits

For set model, S is added
at the end of model No.

Pre-roller model type

PRF 2 - 0200 B

Size
PRF2 PRF3 PRF5

1 Die travel (mm) * Indicated in 4 digits

Mounting block model type

PRB 2 F

Size
PRB2F PRB3F PRB5F

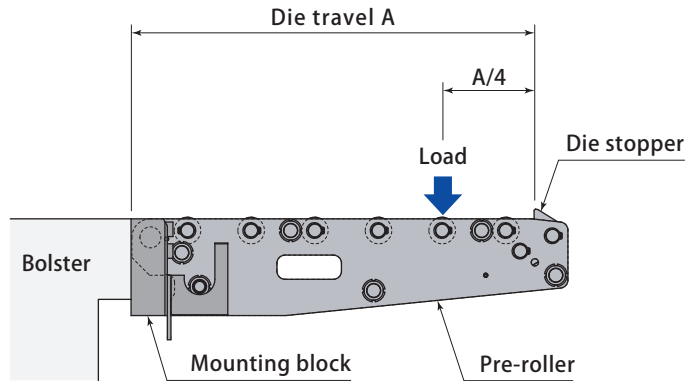

1 Die travel 200 ~ 1000 mm

Die travel		mm	200	250	315	355	400	450	500	560	630	710	800	850	900	950	1000
PRF2	Allowable load *	kN	8	8	5	5	4	4	3	2.5	2.5	—	—	—	—	—	—
	Number of rollers		3	4	4	5	5	6	6	7	7	—	—	—	—	—	—
	Weight	kg	3.1	3.7	4.2	4.7	5.1	5.5	5.9	6.6	7.2	—	—	—	—	—	—
PRF3	Allowable load	kN	—	—	16	16	13	10	8	8	8	6	5	5	4	4	3
	Number of rollers		—	—	4	4	5	5	6	6	7	7	7	8	8	8	9
	Weight	kg	—	—	7.2	8	8.8	9.2	10.1	11	12.1	13.5	14.9	15.9	16.7	17.5	18.4
PRF5	Allowable load	kN	—	—	—	—	25	20	16	16	13	13	10	10	8	8	8
	Number of rollers		—	—	—	—	4	5	5	6	6	7	7	8	8	9	9
	Weight	kg	—	—	—	—	10.4	11.4	12.2	13.6	15.1	16.9	18.1	19.2	20.1	21.5	22.5

● Die loading speed on Pre-roller : Less than 50mm/s ● Die transfer speed : Less than 100mm/s

● Weight does not include mounting block.

* Allowable load is a static load measured at the position of 1/4 of the die travel from the stopper. Select Pre-roller where allowable load (kN) multiplied by the quantity is greater than the die weight. SI conversion : Die weight (kN)=Die weight (kgf)×9.8÷1000

Dimensions

PRF 2 - **0200** B - S

- 1 Die travel (mm)
- * Indicated in 4 digits

PRF2-0200B-S

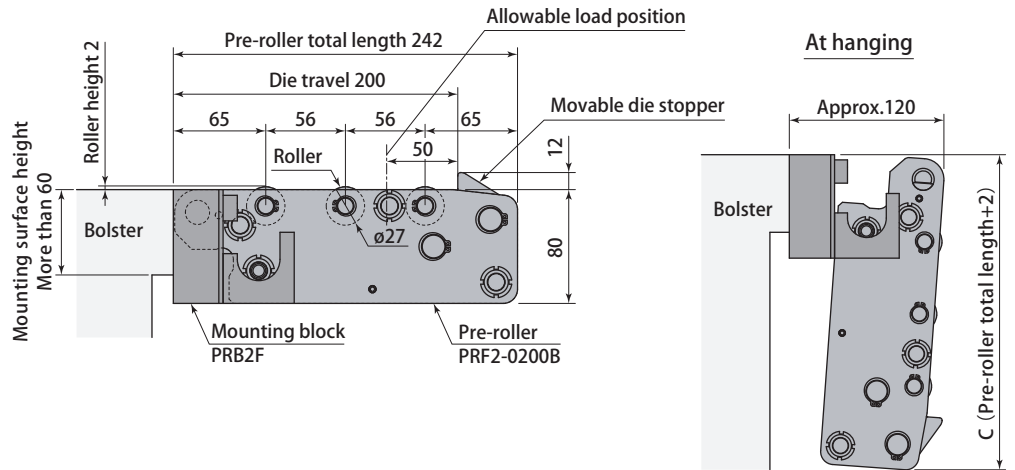
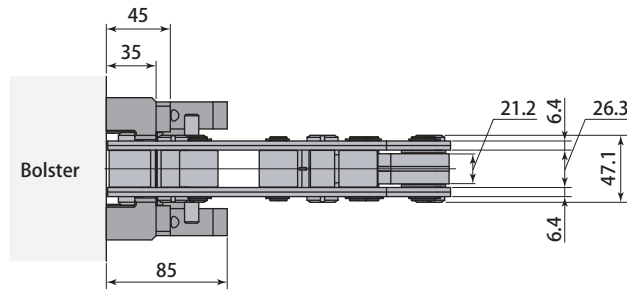

PRF2-0250B-S

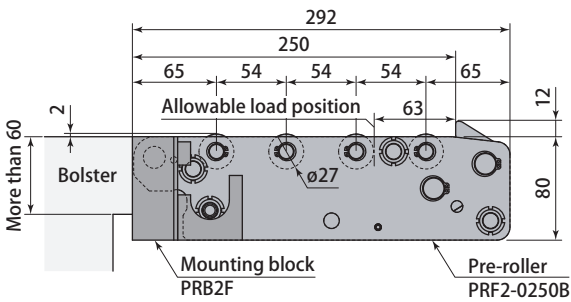

PRF2-0315B-S

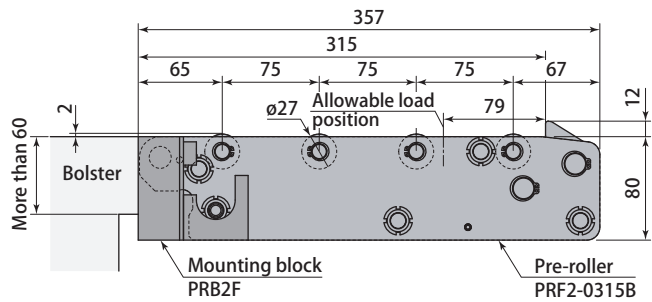

PRF2-0355B-S

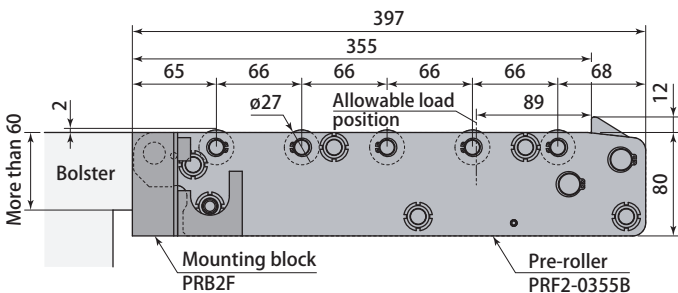

PRF2-0400B-S

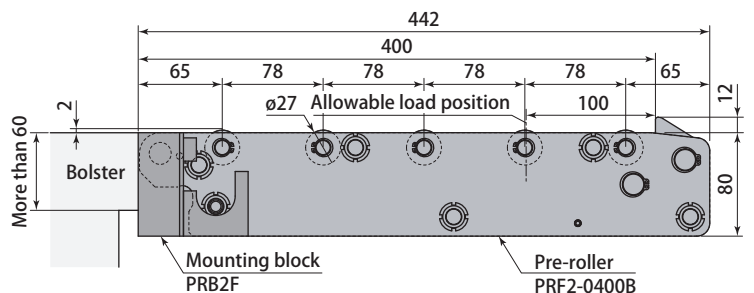

1 Die travel 200 ~ 630 mm

Model	PRF2-0200B	PRF2-0250B	PRF2-0315B	PRF2-0355B	PRF2-0400B	PRF2-0450B	PRF2-0500B	PRF2-0560B	PRF2-0630B
Die travel	mm	200	250	315	355	400	450	500	630
Pre-roller total length	mm	242	292	357	397	442	492	542	672
C	mm	244	294	359	399	444	494	544	674
Weight	kg	3.1	3.7	4.2	4.7	5.1	5.5	5.9	7.2

PRF2-0450B-S

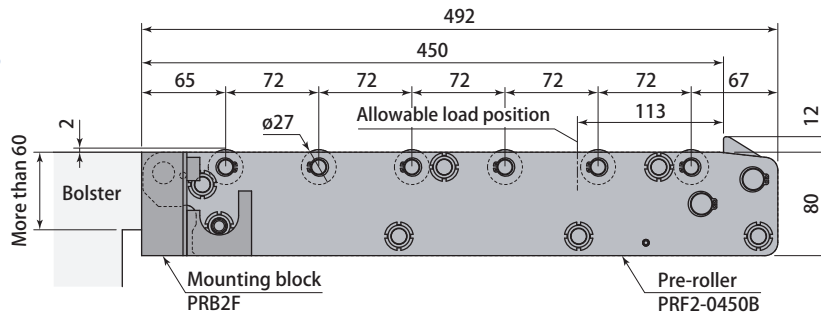

PRF2-0500B-S

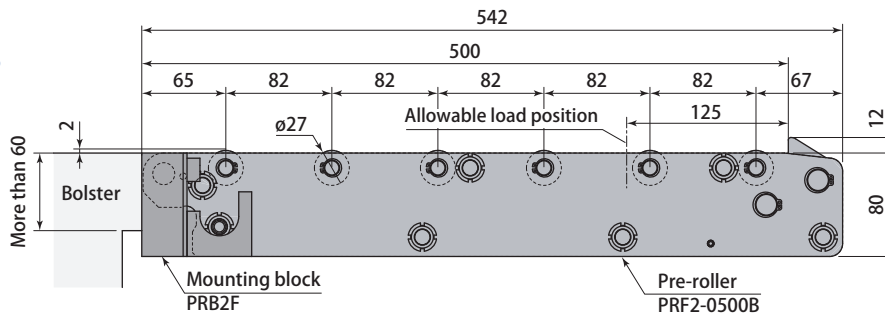

PRF2-0560B-S

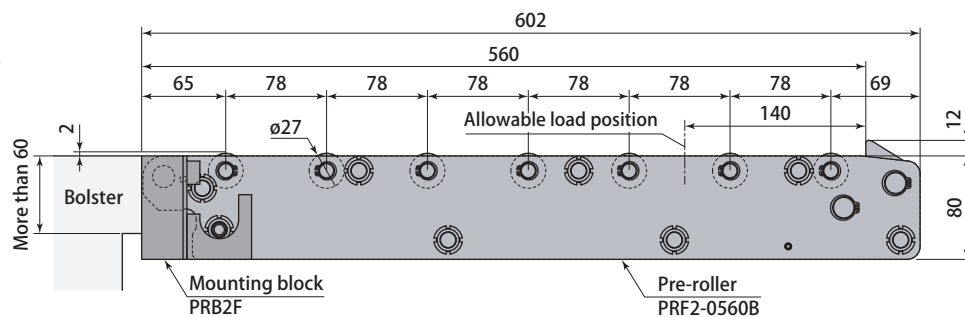

PRF2-0630B-S

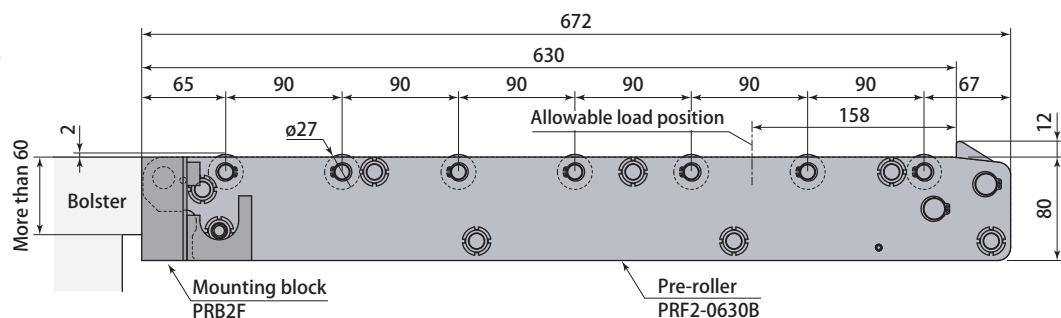

Dimensions

PRF 3 - **0315** B - S

- 1 Die travel (mm)
- * Indicated in 4 digits

PRF3-0315B-S

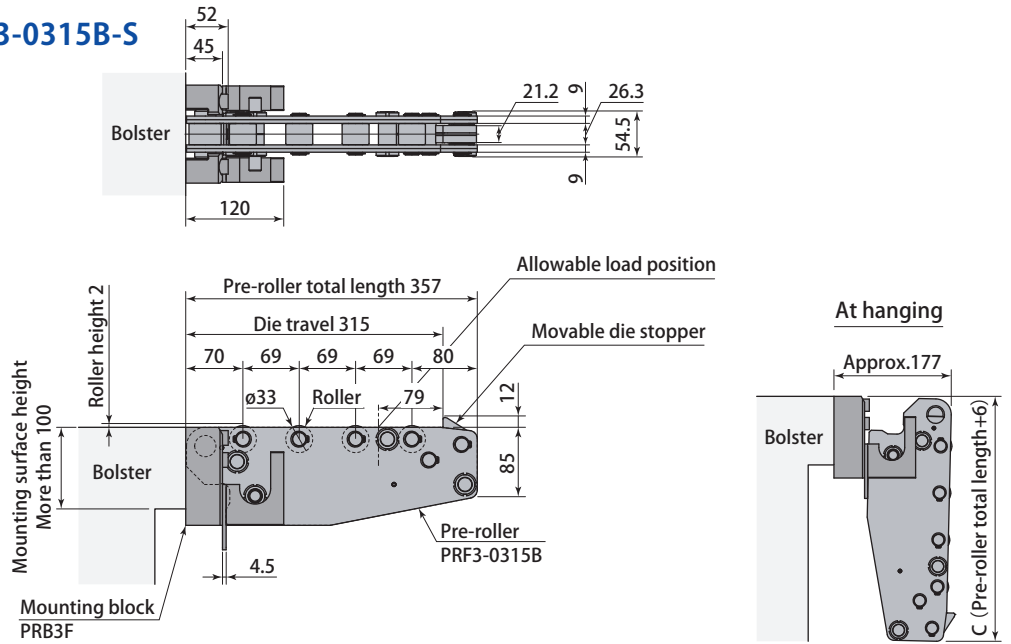

PRF3-0355B-S

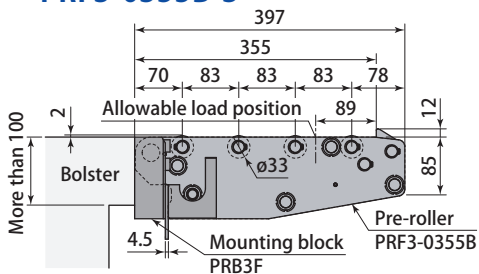

PRF3-0400B-S

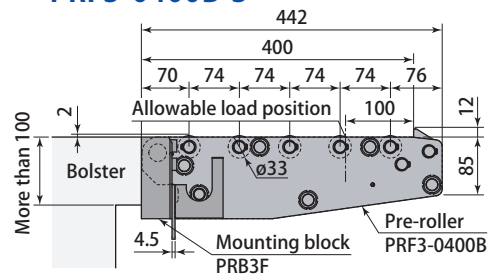

PRF3-0450B-S

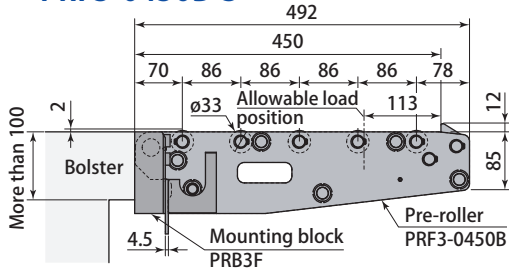

PRF3-0500B-S

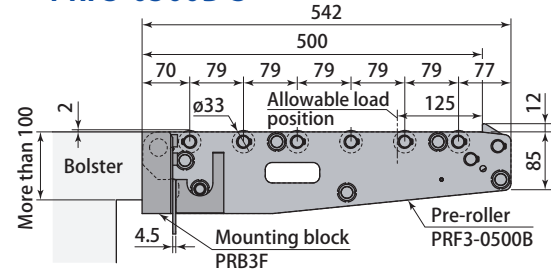

PRF3-0560B-S

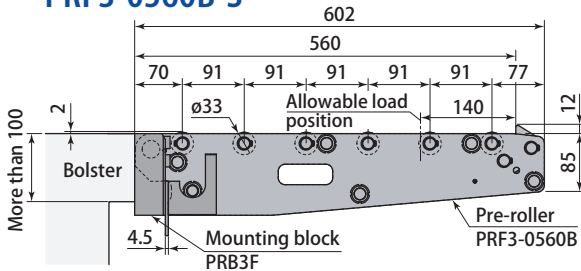

PRF3-0630B-S

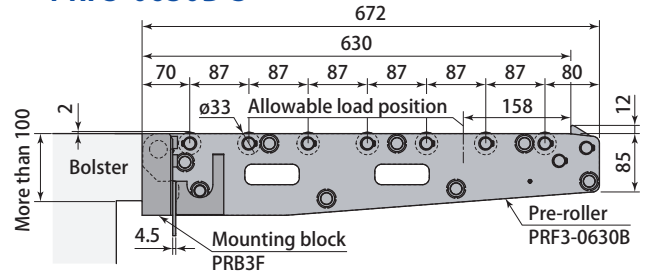

1 Die travel 315 ~ 1000 mm

Model	PRF3-0315B	PRF3-0355B	PRF3-0400B	PRF3-0450B	PRF3-0500B	PRF3-0560B	PRF3-0630B	PRF3-0710B	PRF3-0800B	PRF3-0850B	PRF3-0900B	PRF3-0950B	PRF3-1000B
Die travel mm	315	355	400	450	500	560	630	710	800	850	900	950	1000
Pre-roller total length mm	357	397	442	492	542	602	672	752	842	892	942	992	1042
C mm	363	403	448	498	548	608	678	758	848	898	948	998	1048
Weight kg	7.2	8	8.8	9.2	10.1	11	12.1	13.5	14.9	15.9	16.7	17.5	18.4

PRF3-0710B-S

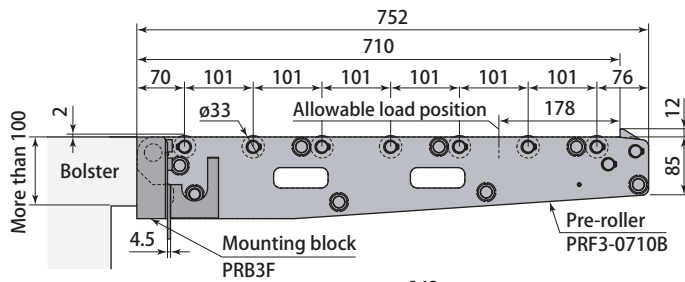

PRF3-0800B-S

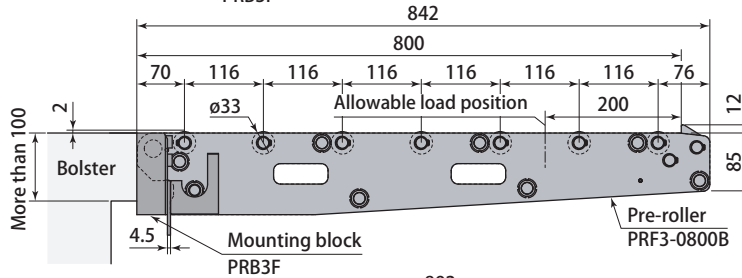

PRF3-0850B-S

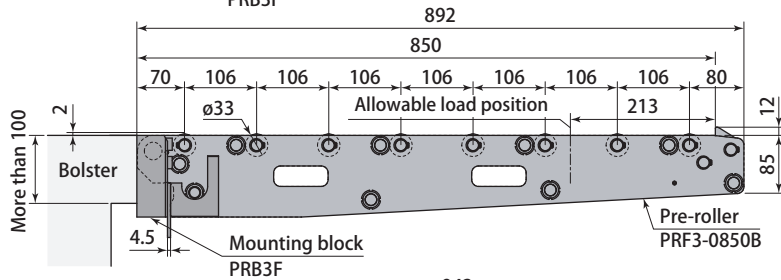

PRF3-0900B-S

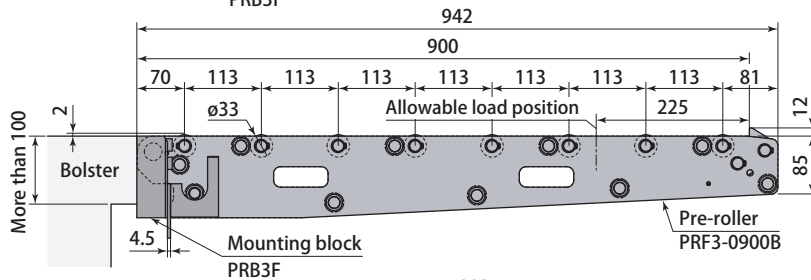

PRF3-0950B-S

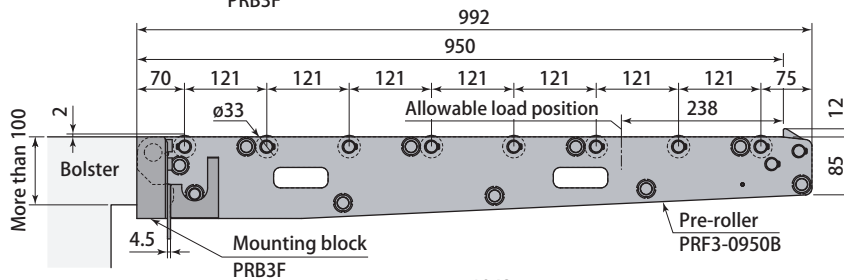

PRF3-1000B-S

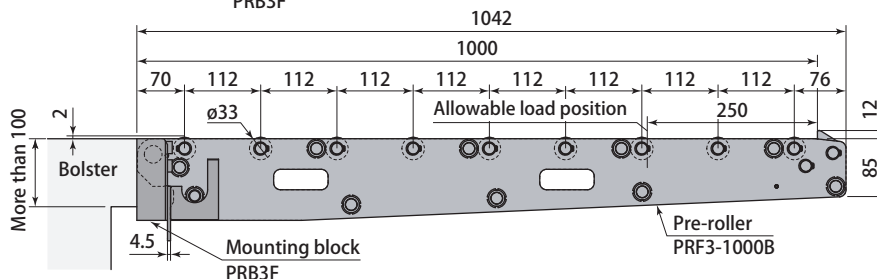

Dimensions

PRF 5 - **0400** B - S

- 1 Die travel (mm)
- * Indicated in 4 digits

PRF5-0400B-S

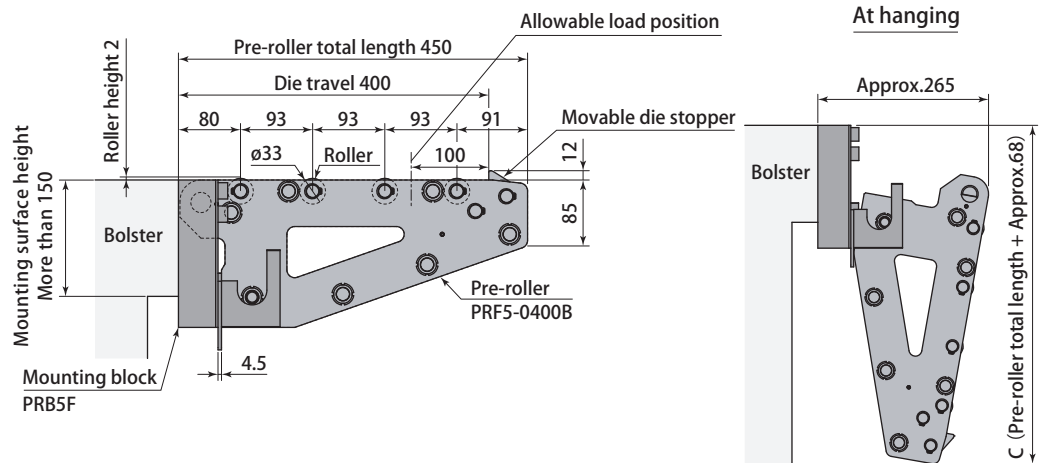
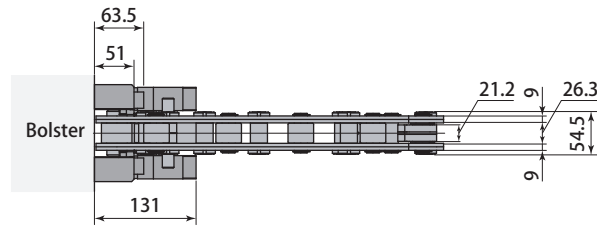

PRF5-0450B-S

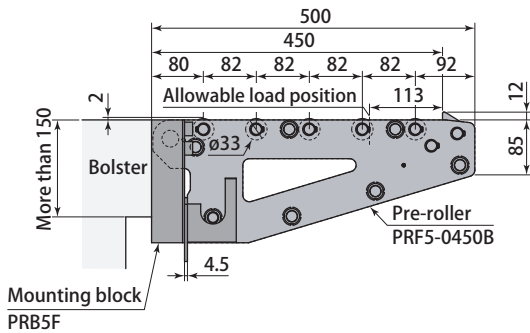

PRF5-0500B-S

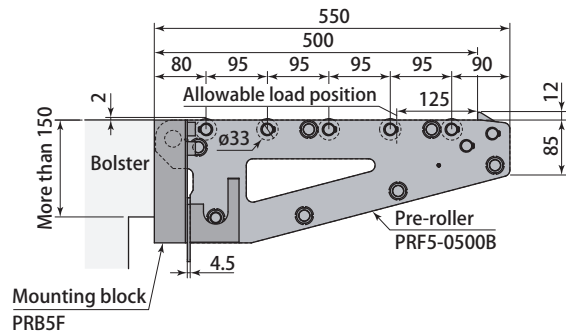

PRF5-0560B-S

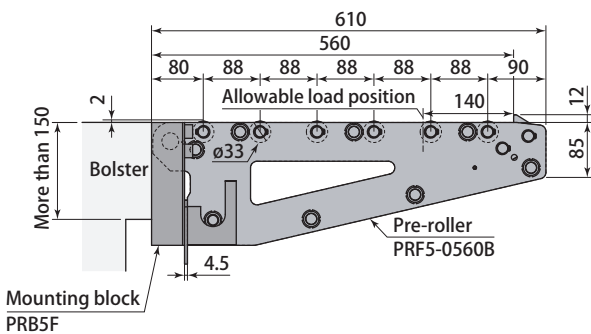

PRF5-0630B-S

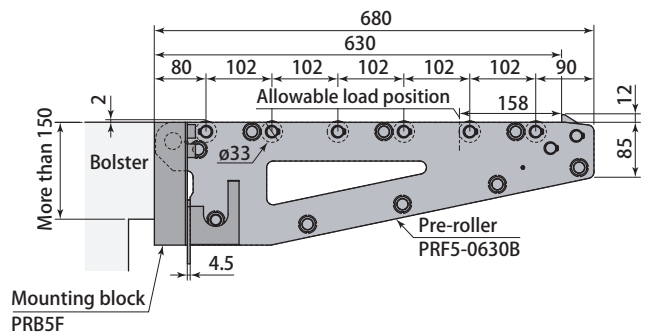

1 Die travel 400 ~ 1000 mm

Model	PRF5-0400B	PRF5-0450B	PRF5-0500B	PRF5-0560B	PRF5-0630B	PRF5-0710B	PRF5-0800B	PRF5-0850B	PRF5-0900B	PRF5-0950B	PRF5-1000B
Die travel mm	400	450	500	560	630	710	800	850	900	950	1000
Pre-roller total length mm	450	500	550	610	680	760	850	900	950	1000	1050
C (Approximately) mm	518	568	618	678	748	828	918	968	1018	1068	1118
Weight kg	10.4	11.4	12.2	13.6	15.1	16.9	18.1	19.2	20.1	21.5	22.5

PRF5-0710B-S

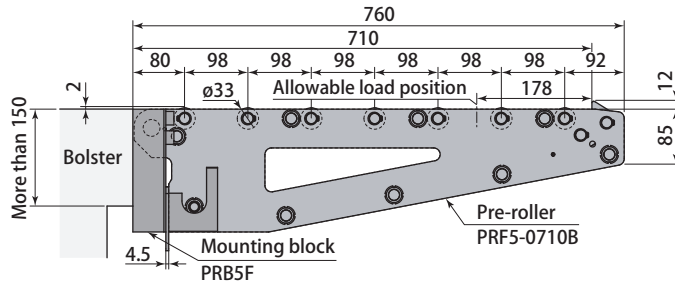

PRF5-0800B-S

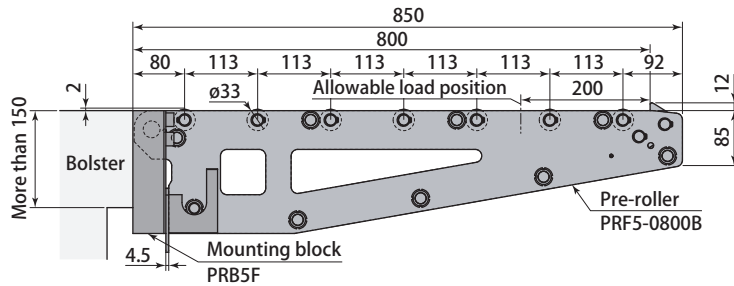

PRF5-0850B-S

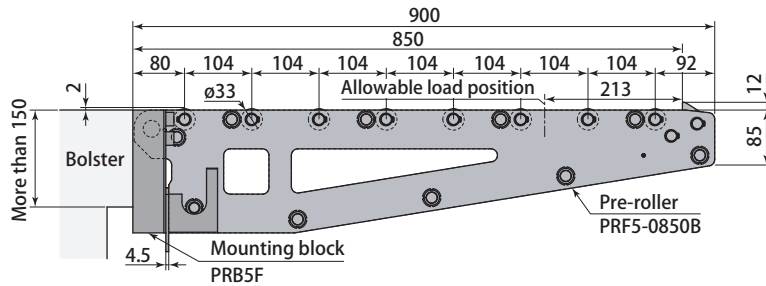

PRF5-0900B-S

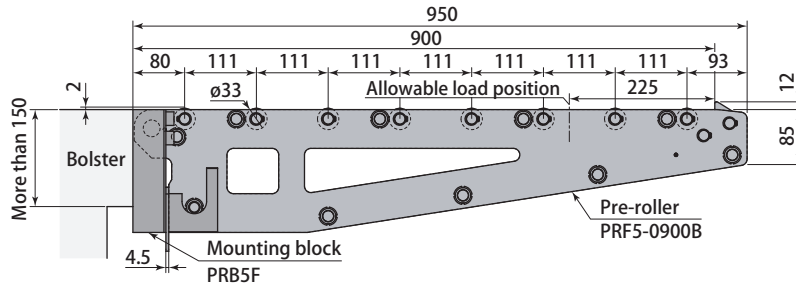

PRF5-0950B-S

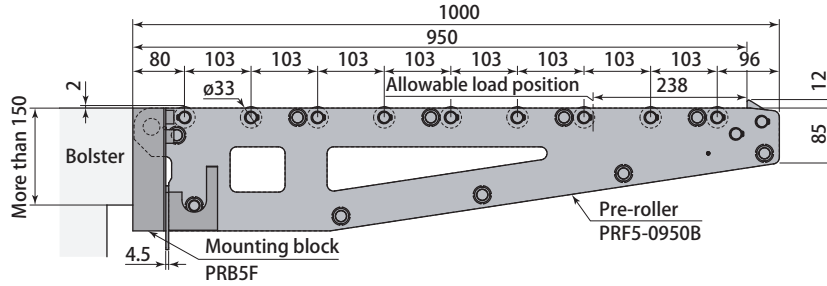

PRF5-1000B-S

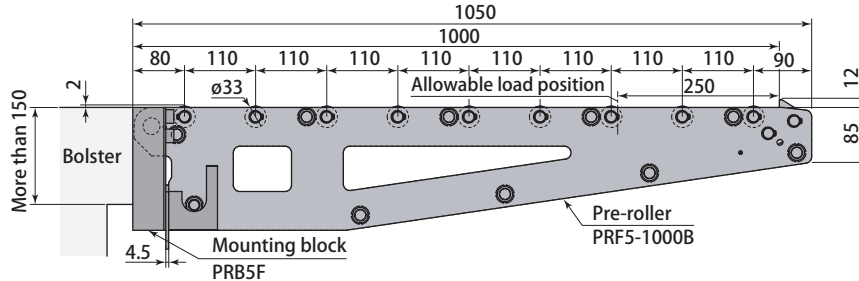

Dimensions, Mounting details

● When using the Die-lifter

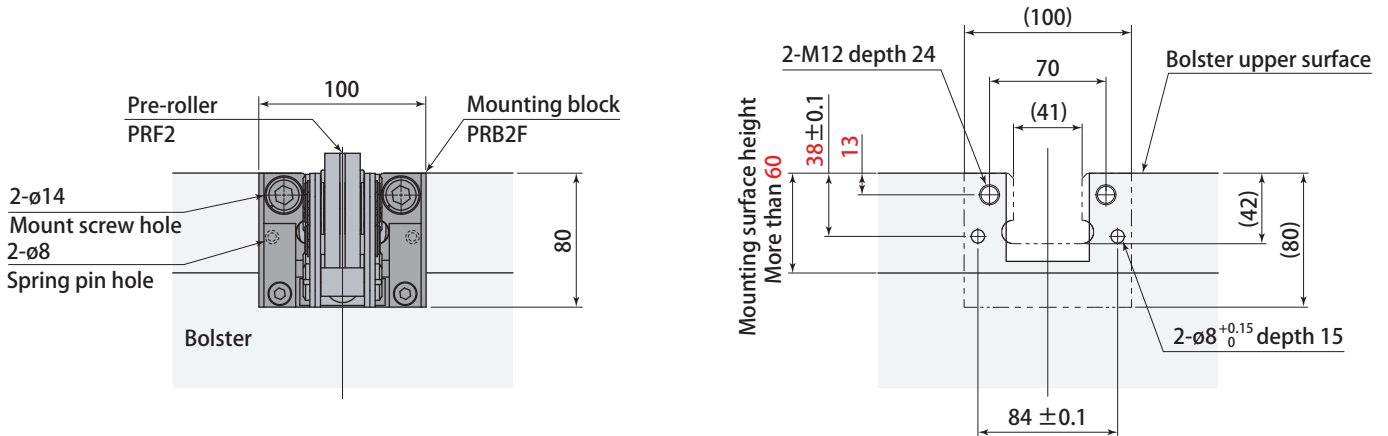

● When not using the Die-lifter

When aligning the level between roller top and bolster surface

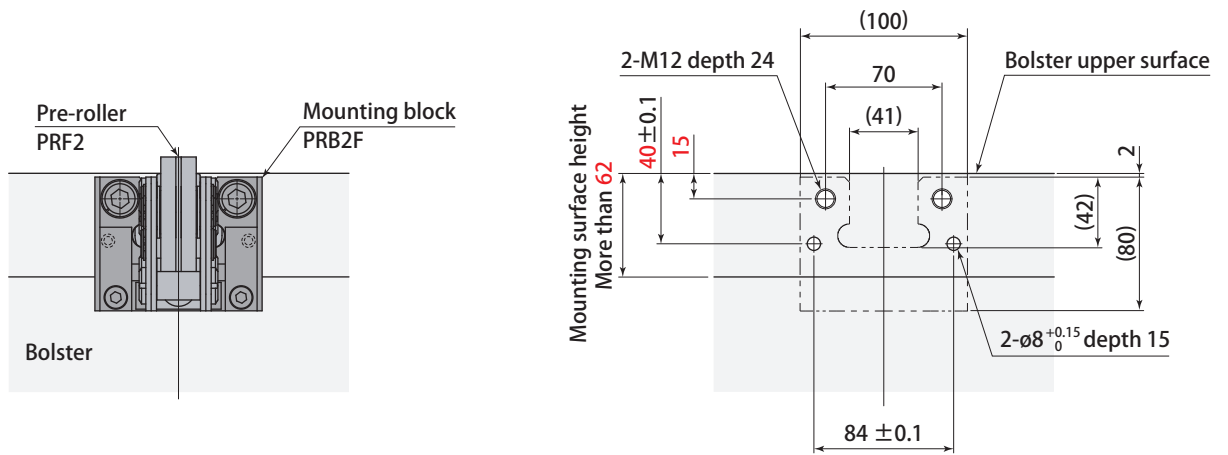

- When machining the spring pin hole, keep the tolerances shown above.
- Drill dia 8mm, 15mm deep hole for spring pin when co-machining the block with mount face.

Model	PRB2F
Weight	kg 2.1
Mount screw	2-M12 length 55
Spring washer	2-M12
Spring pin	2-ø8 length 45

- Mounting block for PRF2

Dimensions, Mounting details

● When using the Die-lifter

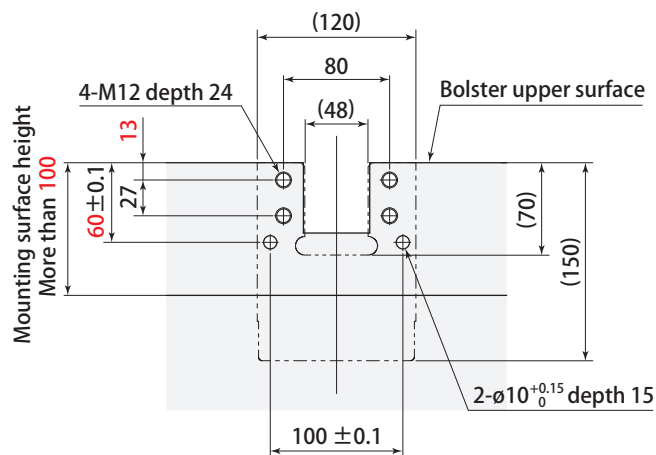
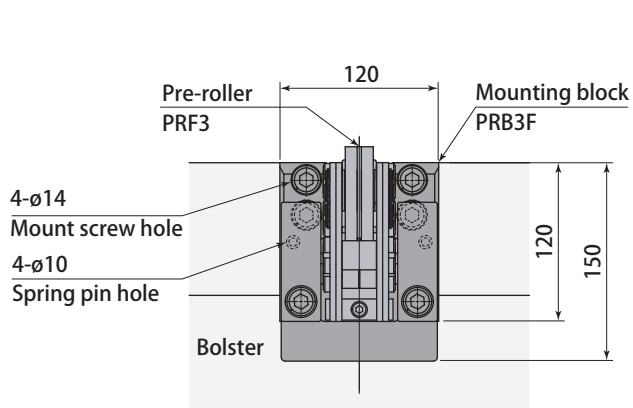

Pre-roller removable & fold
PRF Mounting block

● When not using the Die-lifter

When aligning the level between roller top and bolster surface

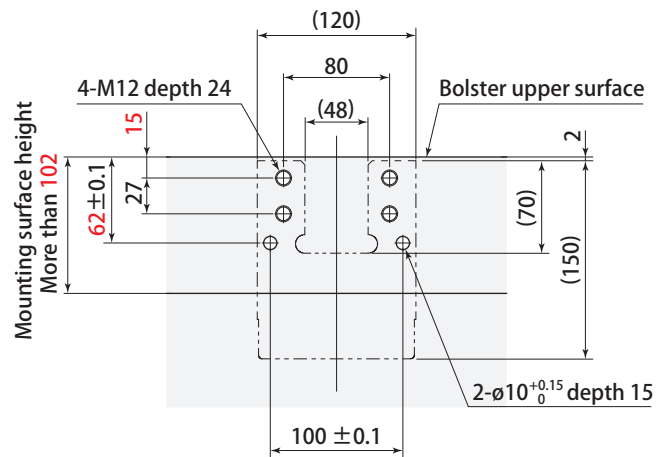
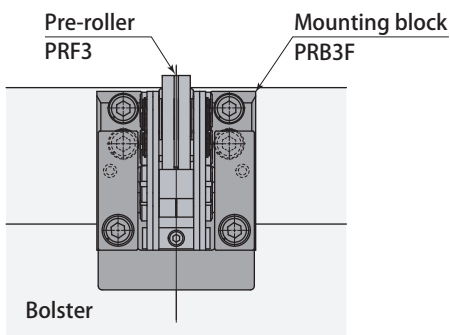

- When machining the spring pin hole, keep the tolerances shown above.
- Drill dia 10mm, 15mm deep hole for spring pin when co-machining the block with mount face.

Model	PRB3F
Weight	kg 5.8
Mount screw	4-M12 length 60
Spring washer	4-M12
Spring pin	2-ø10 length 56

● Mounting block for PRF3

Dimensions, Mounting details

● When using the Die-lifter

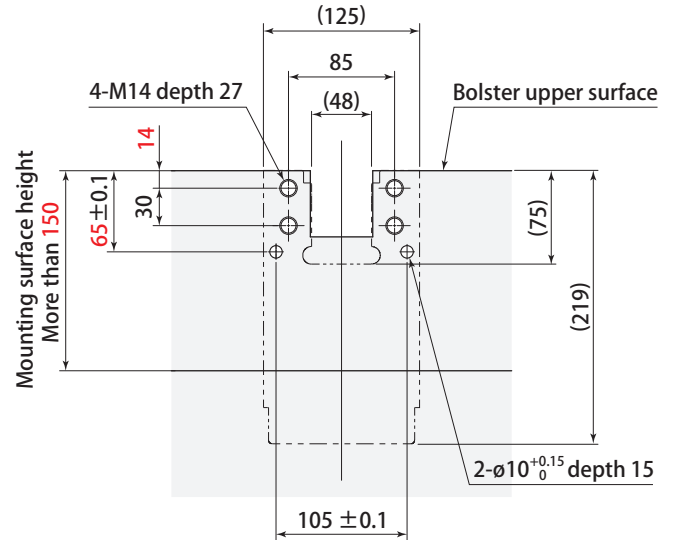
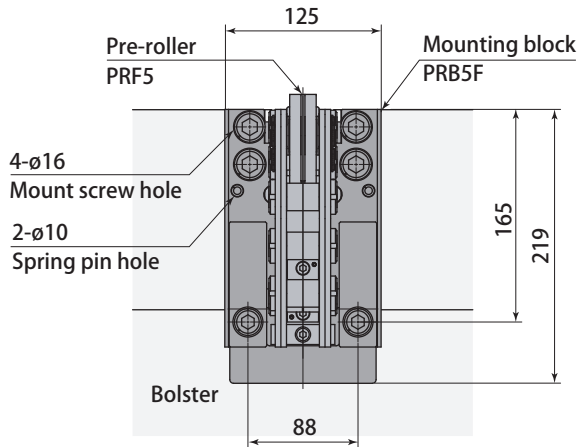

● When not using the Die-lifter

When aligning the level between roller top and bolster surface

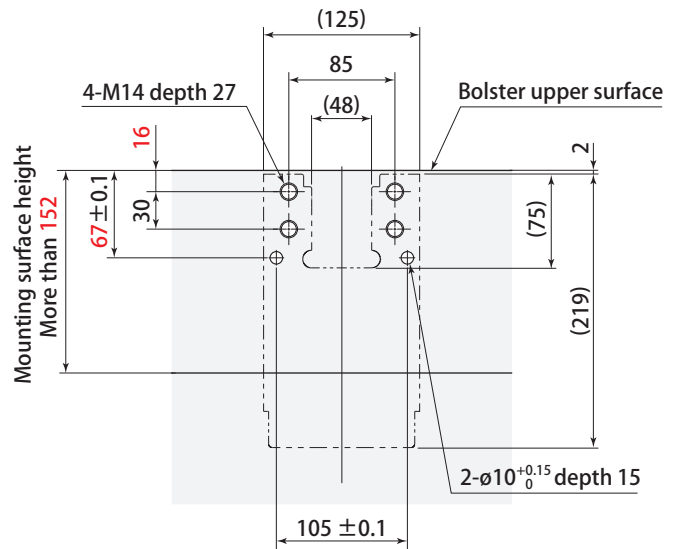
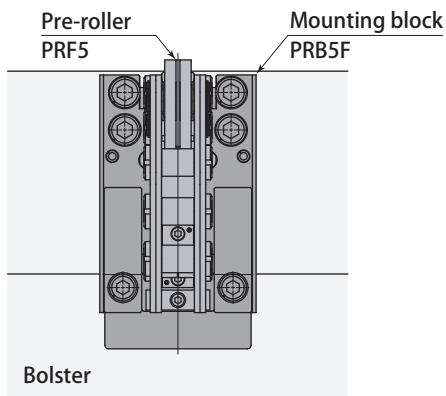

- When machining the spring pin hole, keep the tolerances shown above.
- Drill dia 10mm, 15mm deep hole for spring pin when co-machining the block with mount face.

Model	PRB5F
Weight	kg 10
Mount screw	4-M14 length 75
Spring washer	4-M14
Spring pin	2-ø10 length 63

- Mounting block for PRF5

It is a horizontally fold type of pre-roller which can be folded horizontally.



Pre-roller horizontally fold PRS/T

Folding method

Pre-roller will lock at 0°, 90°, and -90° positions.

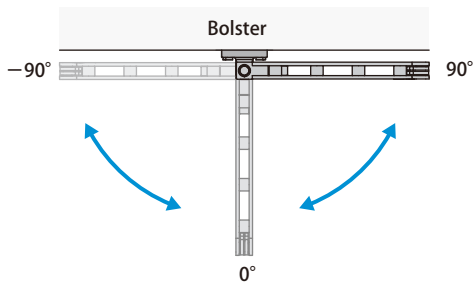

PRS3 PRT3 PRS5 PRT5

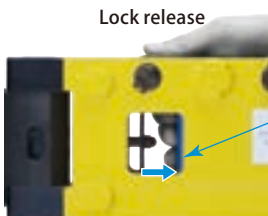
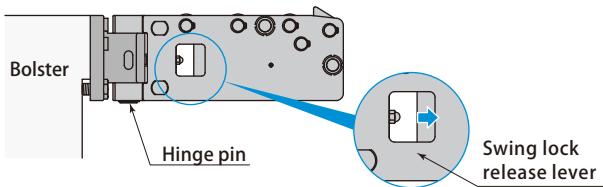

Pull the swing lock release lever to front.

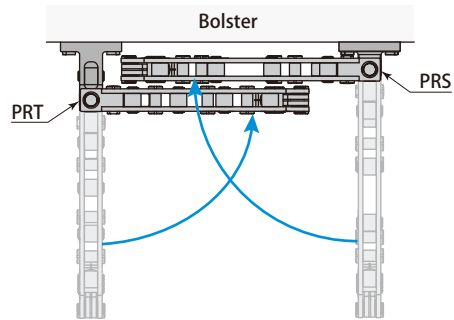

PRS8 PRT8

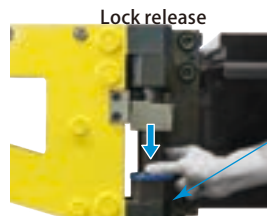
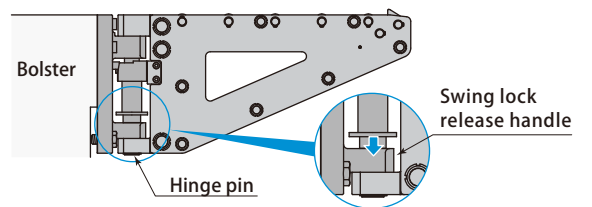

Pull down the swing lock release lever.

- Hinge pins with grease nipples are available as an option to prevent fretting corrosion. Contact Pascal for detail when installing it on high-speed presses.

Model designation

PRS Pre-roller model type

PRS **3** - **0630** B

Size ●
PRS3 PRS5 PRS8

1 Die travel (mm) * Indicated in 4 digits

PRT Pre-roller model type

PRT **3** - **0630** B

Size ●
PRT3 PRT5 PRT8

1 Die travel (mm) * Indicated in 4 digits

Difference of PRS/PRT

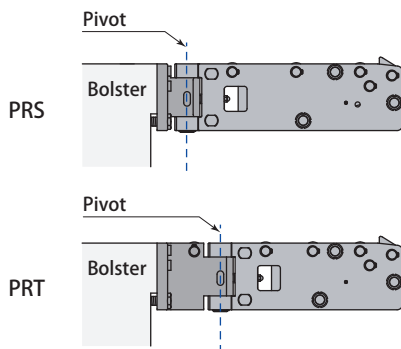

Pivot position is different.

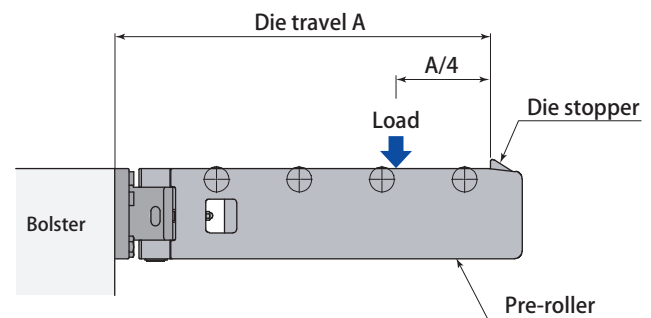

Pre-roller horizontally fold PRS/T

1 Die travel **315** ~ **1000** mm

Die travel		mm	315	355	400	450	500	560	630	710	800	850	900	950	1000
PRS3	Allowable load *	kN	16	16	13	13	10	8	8	6	—	—	—	—	—
	Number of rollers		3	3	3	4	4	5	5	6	—	—	—	—	—
	Weight	kg	11.3	12.1	12.9	14	15	16.2	17.4	19.2	—	—	—	—	—
PRT3	Allowable load	kN	16	16	13	13	10	8	8	6	—	—	—	—	—
	Number of rollers		3	4	4	4	5	6	6	7	—	—	—	—	—
	Weight	kg	12.6	13.5	14.4	15.4	16.4	17.7	18.9	20.6	—	—	—	—	—
PRS5	Allowable load	kN	—	—	—	—	16	16	16	13	10	10	8	8	6
	Number of rollers		—	—	—	—	5	5	5	6	7	7	7	8	8
	Weight	kg	—	—	—	—	24.3	26	28	30.4	33.1	34.4	35.8	37.4	38.8
PRT5	Allowable load	kN	—	—	—	—	16	16	16	13	10	10	8	8	6
	Number of rollers		—	—	—	—	5	5	5	6	7	7	7	8	8
	Weight	kg	—	—	—	—	27.3	28.9	30.8	33.3	36.1	37.5	38.9	40.4	41.5
PRS8	Allowable load	kN	—	—	—	—	—	—	25	20	16	16	16	13	13
	Number of rollers		—	—	—	—	—	—	5	6	6	7	7	8	8
	Weight	kg	—	—	—	—	—	—	44.8	47.3	49.9	51.5	52.9	54.6	56.1
PRT8	Allowable load	kN	—	—	—	—	—	—	25	20	16	16	16	13	13
	Number of rollers		—	—	—	—	—	—	5	6	7	7	8	8	8
	Weight	kg	—	—	—	—	—	—	51.1	53.5	56.5	57.9	59.5	60.9	62.3

● Die loading speed on Pre-roller : Less than 50mm/s ● Die transfer speed : Less than 100mm/s

* Allowable load is a static load measured at the position of 1/4 of the Die travel from the stopper. Select Pre-roller where allowable load (kN) multiplied by the quantity is greater than the die weight. SI conversion : Die weight (kN)=Die weight (kgf)×9.8÷1000

External dimension

PRS 5 - 0500 B

1 Die travel (mm)
* Indicated in 4 digits

PRT 5 - 0500 B

1 Die travel (mm)
* Indicated in 4 digits

PRS5-0500B

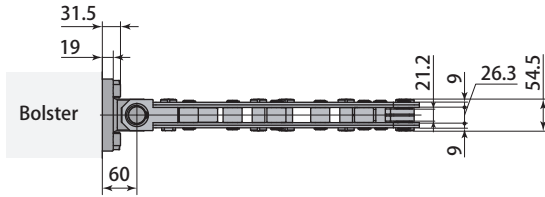

PRT5-0500B

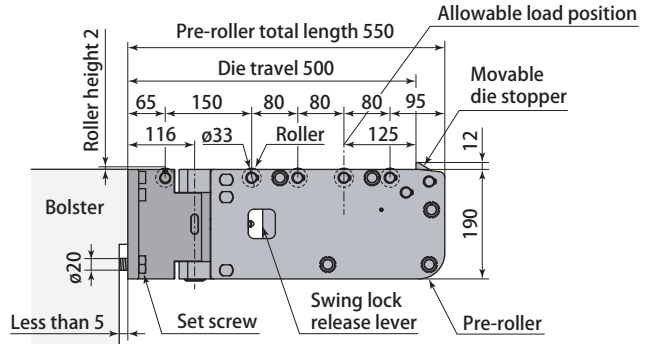
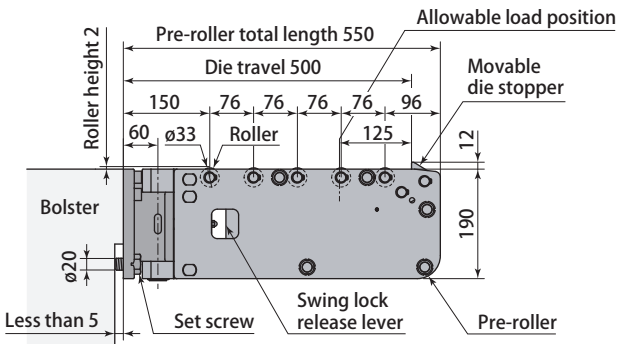
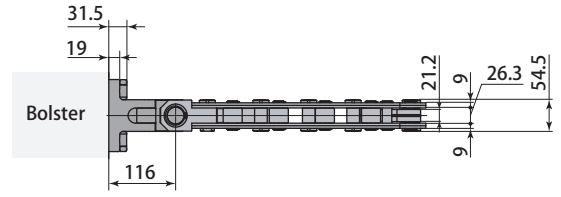

PRS5-0560B

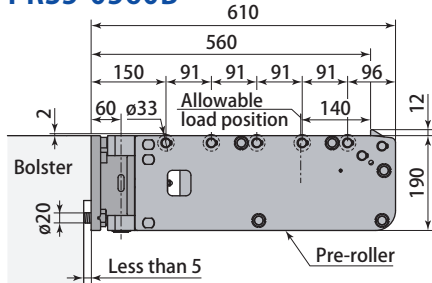

PRT5-0560B

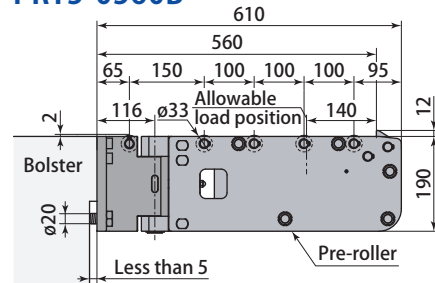

PRS5-0630B

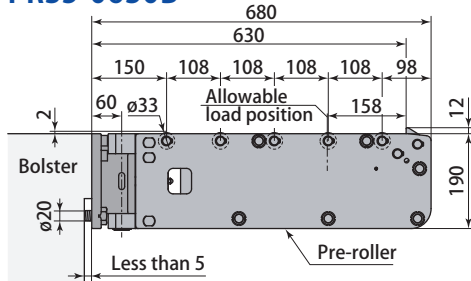

PRT5-0630B

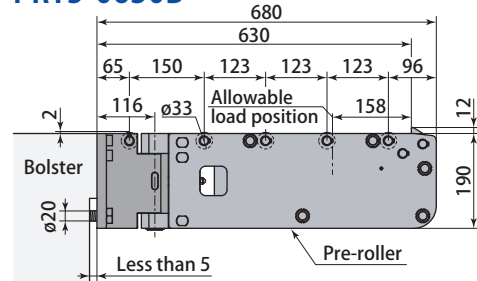

PRS5-0710B

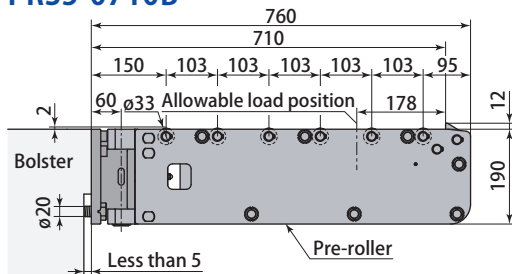

PRT5-0710B

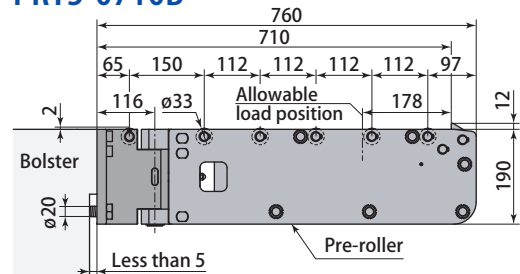

Pre-roller horizontally fold PRS/T

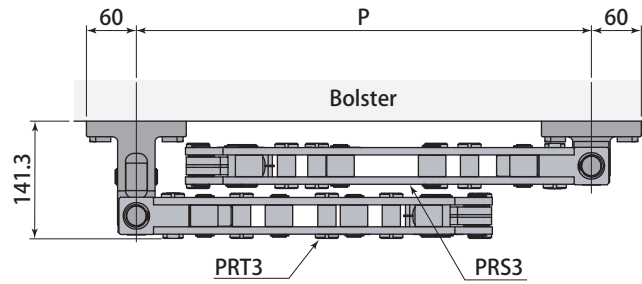

Minimum mounting pitch

mm

Model	PRS3-0315B	PRS3-0355B	PRS3-0400B	PRS3-0450B	PRS3-0500B	PRS3-0560B	PRS3-0630B	PRS3-0710B
	PRT3-0315B	PRT3-0355B	PRT3-0400B	PRT3-0450B	PRT3-0500B	PRT3-0560B	PRT3-0630B	PRT3-0710B
Minimum mounting pitch P	362	402	447	497	547	607	677	757

Mounting details

● When using the Die-lifter

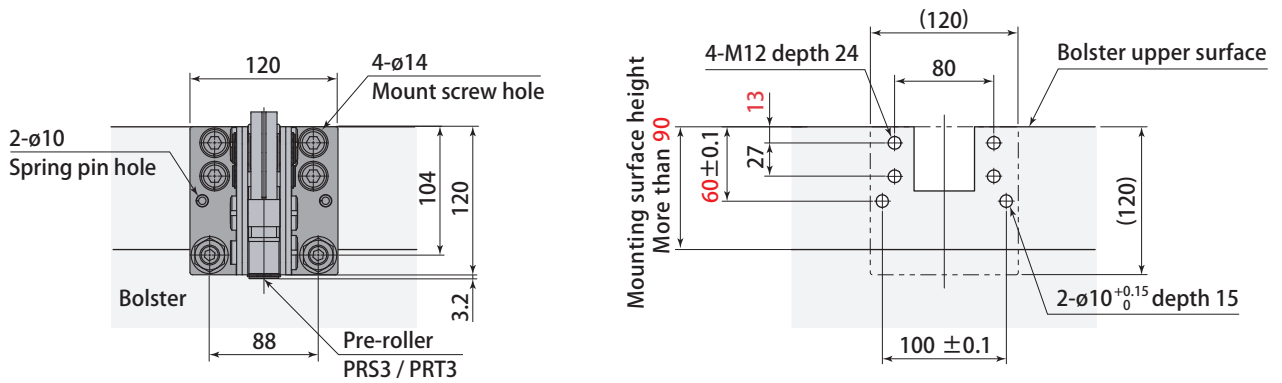

● When not using the Die-lifter

When aligning the level between roller top and bolster surface

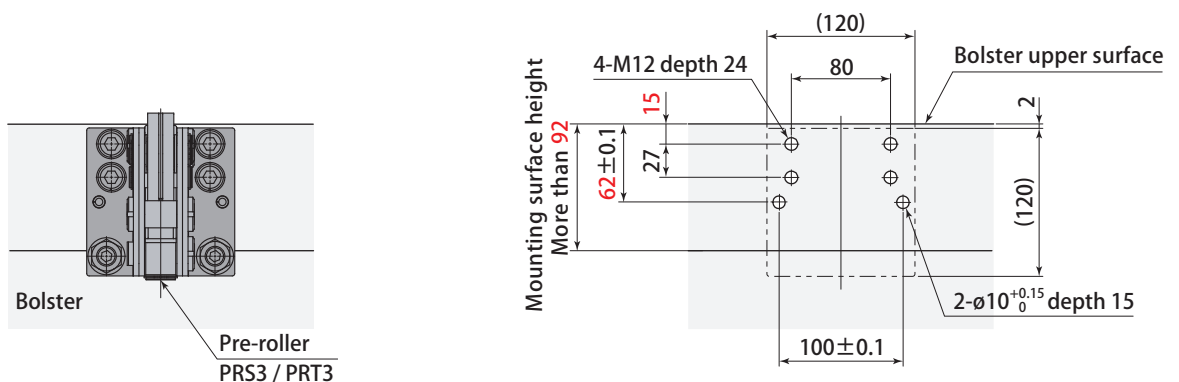

- When machining the spring pin hole, keep the tolerances shown above.
- Drill dia 10mm, 15mm deep hole for spring pin when co-machining the block with mount face.

Included

Pre-roller model type	PRS3 / PRT3
Mount screw	4-M12 length 35
Spring washer	4-M12
Spring pin	2-C10 length 32

Pre-roller horizontally fold
PRS/T Mounting details

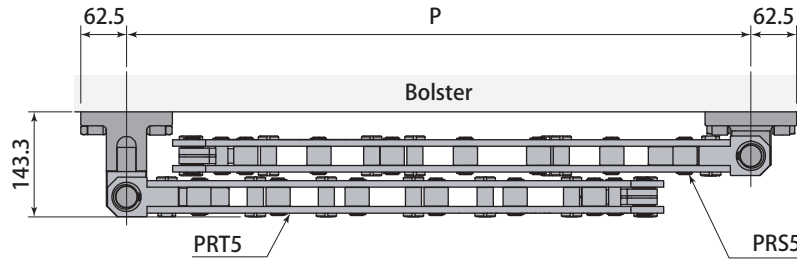

Minimum mounting pitch

mm

Model	PRS5-0500B	PRS5-0560B	PRS5-0630B	PRS5-0710B	PRS5-0800B	PRS5-0850B	PRS5-0900B	PRS5-0950B	PRS5-1000B
	PRT5-0500B	PRT5-0560B	PRT5-0630B	PRT5-0710B	PRT5-0800B	PRT5-0850B	PRT5-0900B	PRT5-0950B	PRT5-1000B
Minimum mounting pitch P	553	613	683	763	853	903	953	1003	1053

Mounting details

● When using the Die-lifter

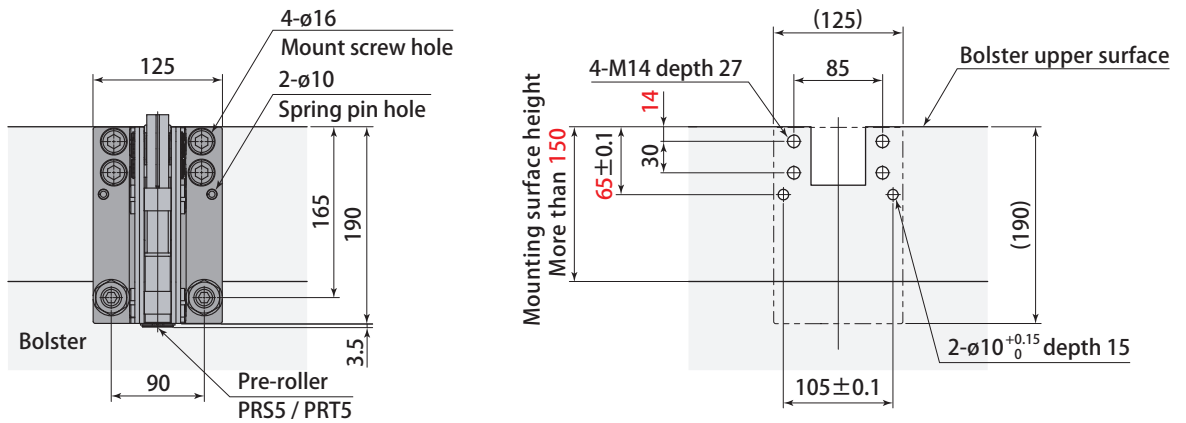

Pre-roller horizontally fold
PRS/T Mounting details

● When not using the Die-lifter

When aligning the level between roller top and bolster surface

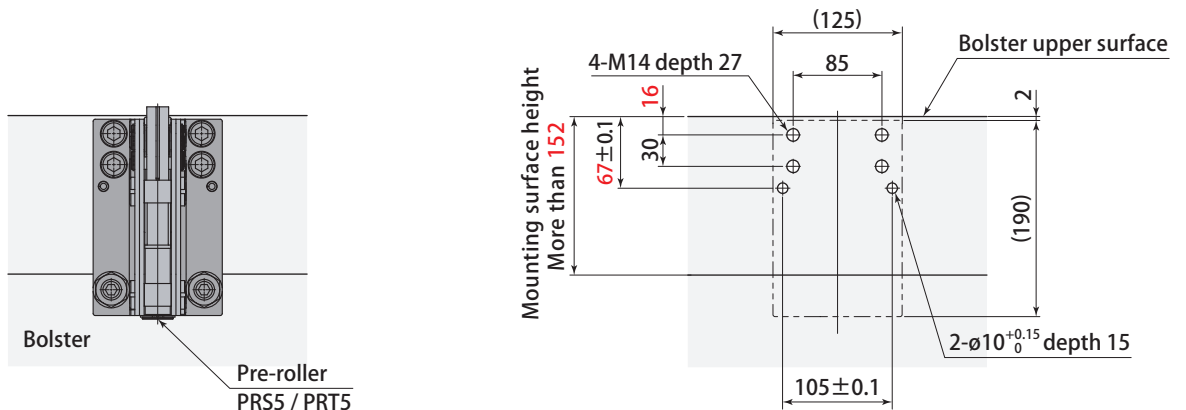

- When machining the spring pin hole, keep the tolerances shown above.
- Drill dia 10mm, 15mm deep hole for spring pin when co-machining the block with mount face.

Included

Pre-roller model type	PRS5 / PRT5
Mount screw	4-M14 length 40
Spring washer	4-M14
Spring pin	2-C10 length 32

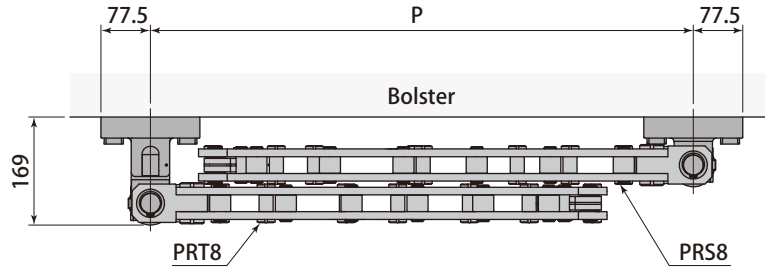

Minimum mounting pitch

Model	PRS8-0630B	PRS8-0710B	PRS8-0800B	PRS8-0850B	PRS8-0900B	PRS8-0950B	PRS8-1000B
	PRT8-0630B	PRT8-0710B	PRT8-0800B	PRT8-0850B	PRT8-0900B	PRT8-0950B	PRT8-1000B
Minimum mounting pitch P	680	760	850	900	950	1000	1050

Mounting details

● When using the Die-lifter

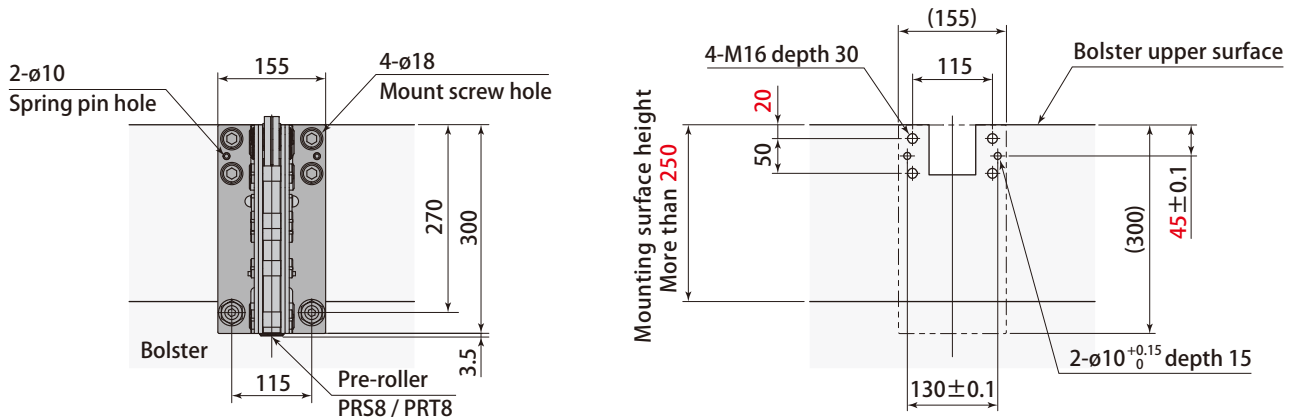

● When not using the Die-lifter

When aligning the level between roller top and bolster surface

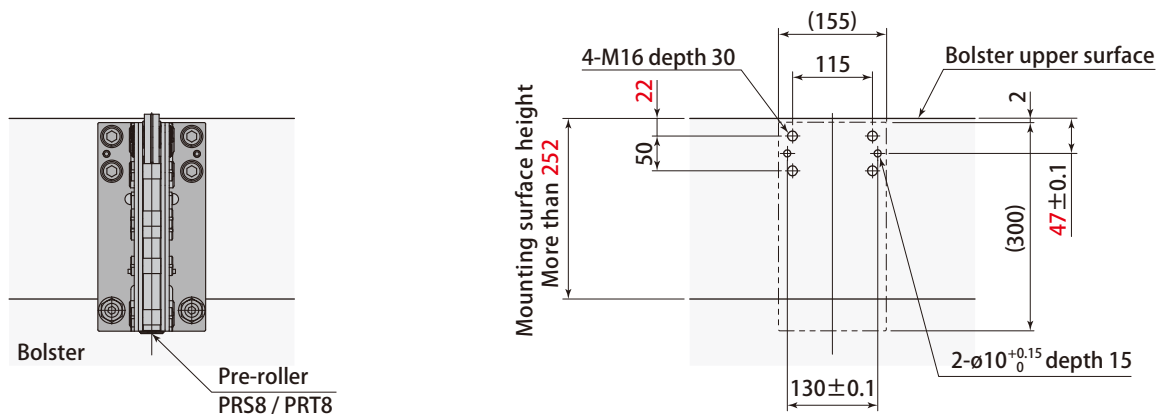

- When machining the spring pin hole, keep the tolerances shown above.
- Drill dia 10mm, 15mm deep hole for spring pin when co-machining the block with mount face.

Included

Pre-roller model type	PRS8 / PRT8
Mount screw	4-M16 length 55
Spring washer	4-M16
Spring pin	2-C10 length 45

Pre-roller horizontally fold PRS/T Mounting details

Set screw (PRS 3 / PRT3 , PRS 5 / PRT 5 , PRS 8 / PRT 8)

The set screw is included to all the models for PRS/T.

Model	PRS 3 / PRT3	
Bolster width (Mounting surface height)	70mm ~ 90mm	More than 90mm
Set screw	Required	Not required

Model	PRS 5 / PRT 5	
Bolster width (Mounting surface height)	75mm ~ 150mm	More than 150mm
Set screw	Required	Not required

Model	PRS 8 / PRT 8	
Bolster width (Mounting surface height)	85mm ~ 250mm	More than 250mm
Set screw	Required	Not required

● The set screw is used to prevent the inclination of pre-roller, in case that the mounting surface height is short.

Pre-roller horizontally fold
PRS/T
Caution in use

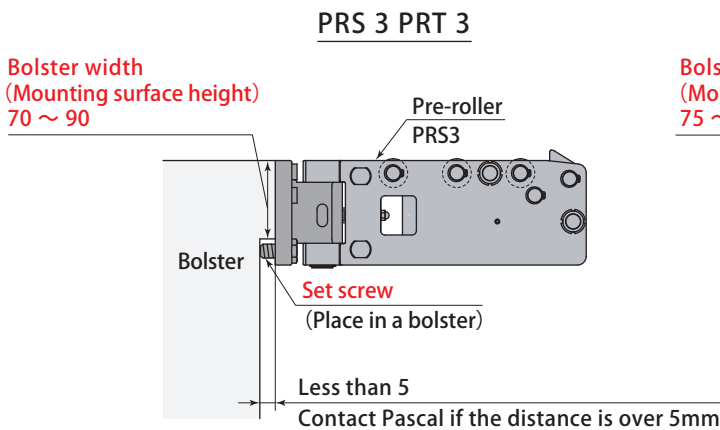

* This drawing is PRS3-0315B.

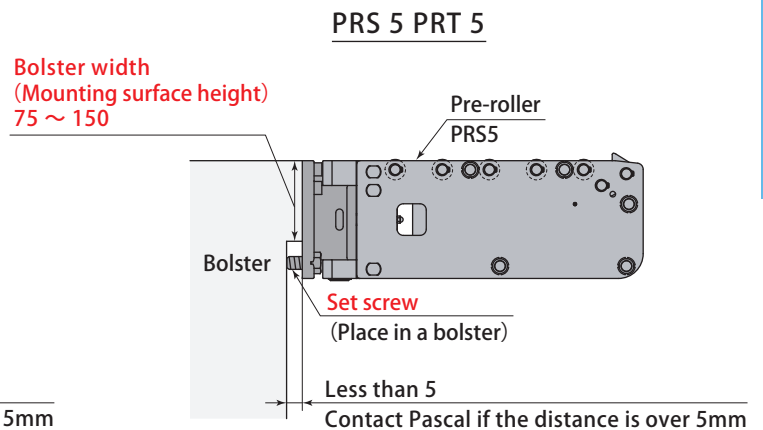

* This drawing is PRS5-0500B.

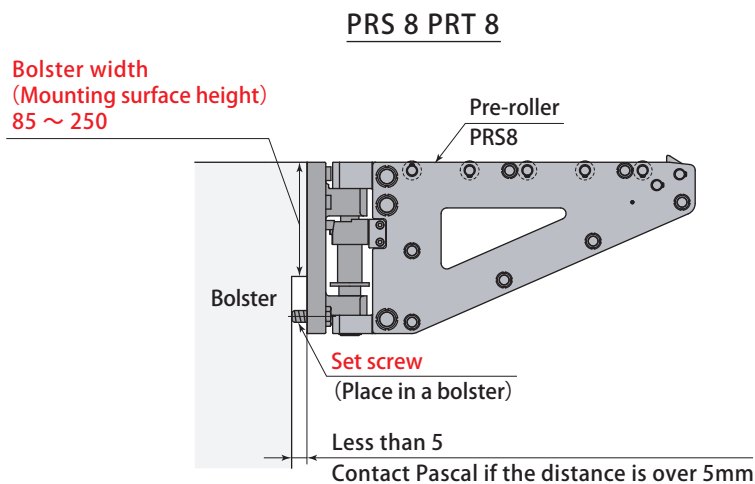

* This drawing is PRS8-0630B.

It is heavy load type of pre-roller which attaches pillar to the removal type PRA.



Pre-roller heavy load
PRC

At installation

At removal

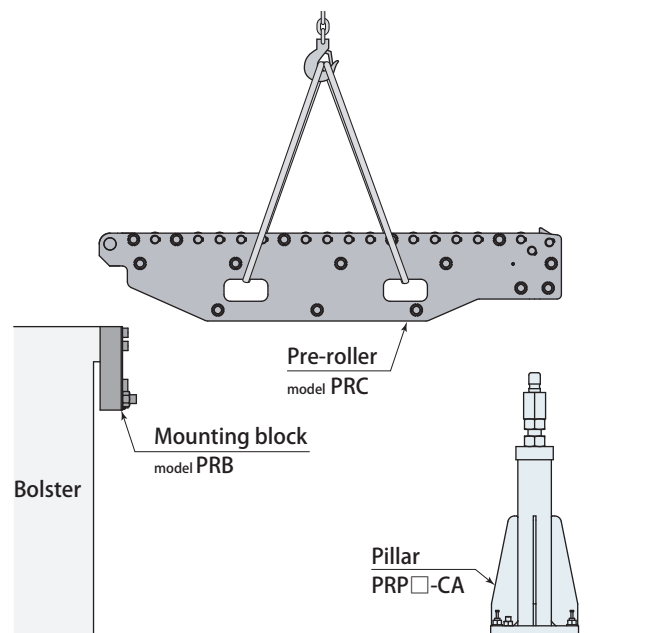
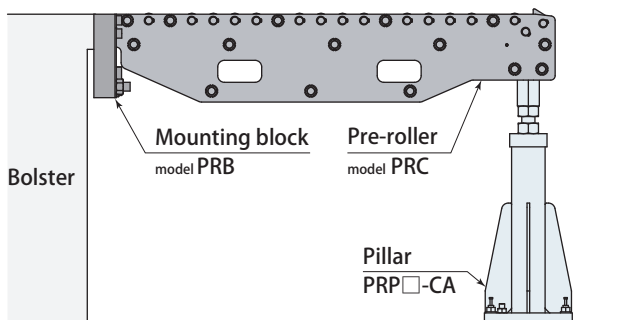

- The Pre-roller may be damaged due to the vibration through stamping operation. The removal of pre-roller during the operation is recommended.

Model designation

Set model (Pre-roller + Mounting block + Pillar)

PRC **3** - **0710** B **0300** - S

Size
PRC3 PRC5

1 Die travel (mm) * Indicated in 4 digits

Pillar size * Indicated in 4 digits
Refer to page → 187

For set model,
S is added at the end of model No.

Pre-roller model type

PRC **3** - **0710** B

Size
PRC3 PRC5

1 Die travel (mm) * Indicated in 4 digits

Mounting block model type

PRB **3**

Size
PRB3 PRB5

Pillar model type

PRP **0300** - CA

Pillar size * Indicated in 4 digits
Refer to page → 187

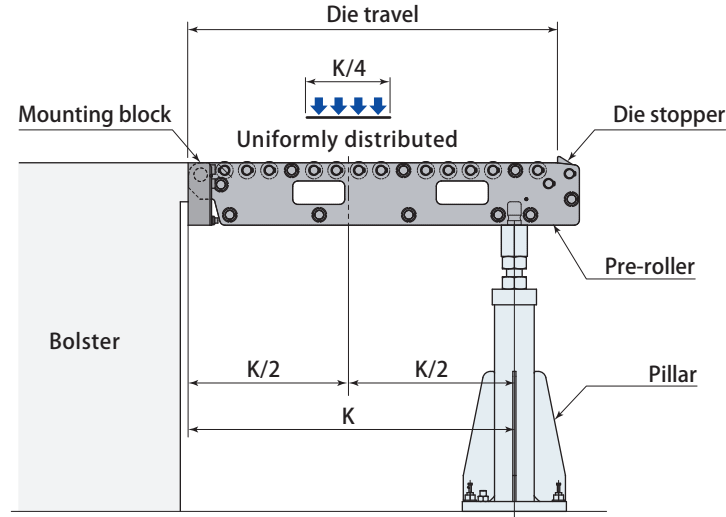

1 Die travel **710** ~ **1250** mm

Die travel		mm	710	800	850	900	950	1000	1250
PRC3	Allowable load *	kN	30	30	25	25	25	20	16
	Number of rollers		12	12	14	14	16	16	22
	Weight	kg	15.4	16.9	18.3	19.2	20.5	21.3	27.5
PRC5	Allowable load	kN	—	—	—	—	—	35	35
	Number of rollers		—	—	—	—	—	14	18
	Weight	kg	—	—	—	—	—	29.8	38

● Die loading speed on Pre-roller : Less than 50mm/s ● Die transfer speed : Less than 100mm/s

● Weight does not include mounting block and pillar.

* Allowable load is uniformly distributed and is held by the middle part of the Pre-roller. Select Pre-roller where allowable load (kN) multiplied by the quantity is greater than the die weight. SI conversion : Die weight (kN)=Die weight (kgf) × 9.8 ÷ 1000

Dimensions

PRC 3 – 0710 B 0300 – S

1 Die travel (mm) •.....
* Indicated in 4 digits

Pillar size •.....
* Indicated in 4 digits

1 Die travel 710 ~ 1250 mm

Model	PRC3-0710B	PRC3-0800B	PRC3-0850B	PRC3-0900B	PRC3-0950B	PRC3-1000B	PRC3-1250B
Die travel	mm 710	800	850	900	950	1000	1250
Pre-roller total length	mm 752	842	892	942	992	1042	1292
Weight	kg 15.4	16.9	18.3	19.2	20.5	21.3	27.5

PRC3-0710B□-S

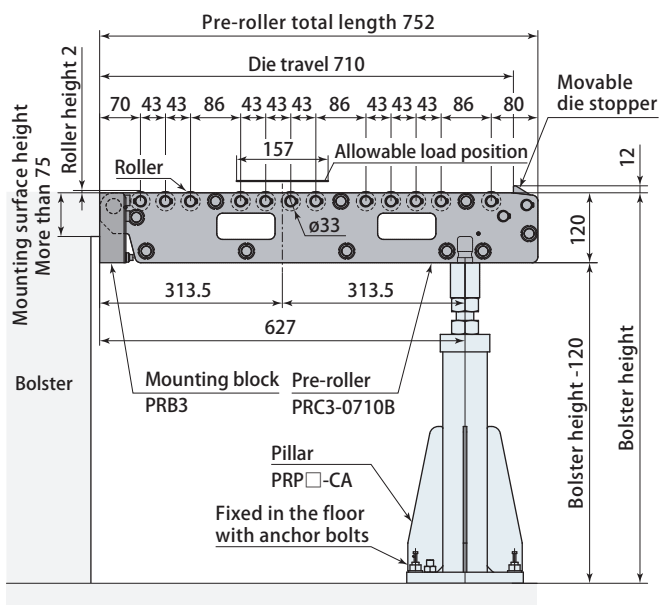
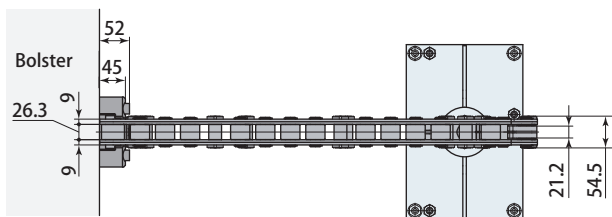

Refer to **page → 187** for Pillar.

PRC3-0800B□-S

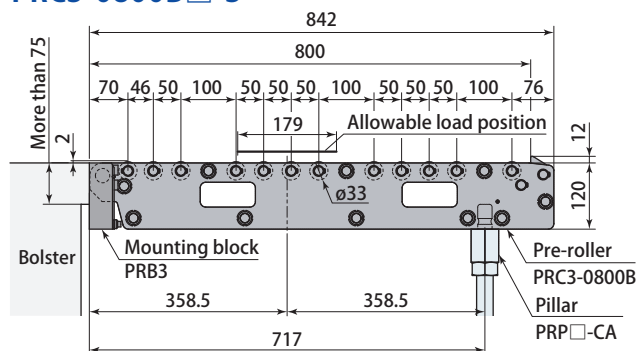

PRC3-0850B□-S

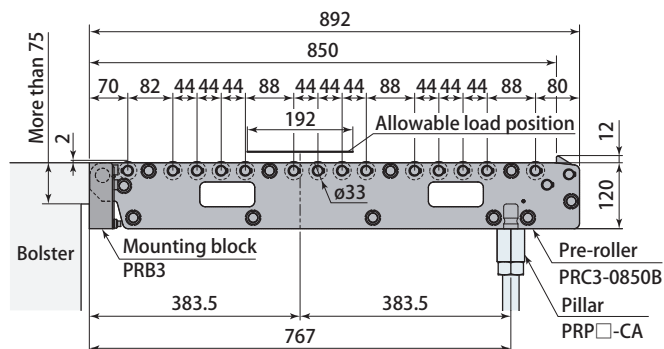

Pre-roller heavy load PRC

PRC3-0900B□-S

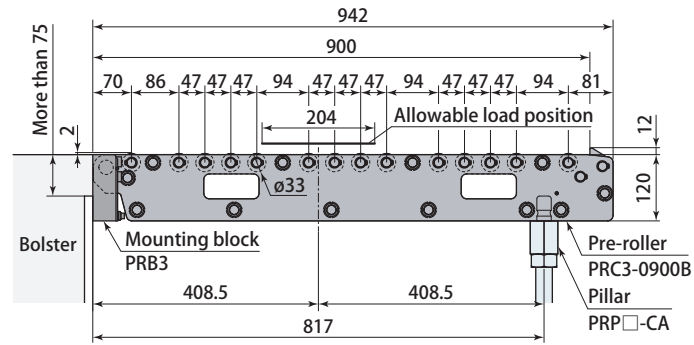

PRC3-0950B□-S

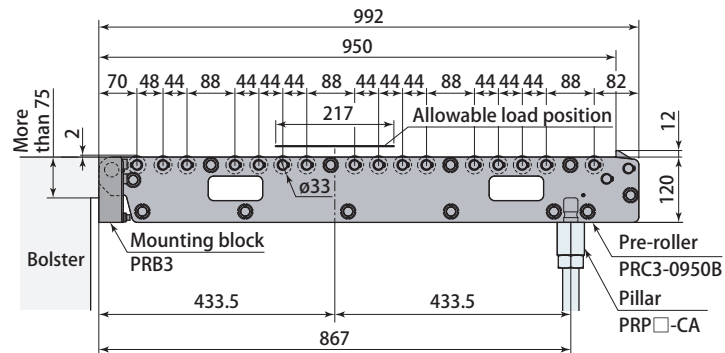

PRC3-1000B□-S

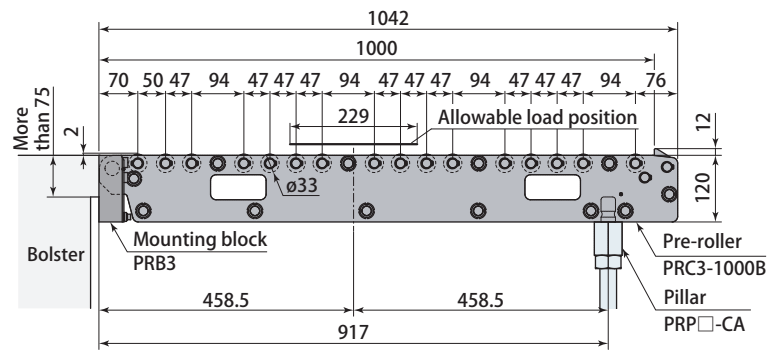

PRC3-1250B□-S

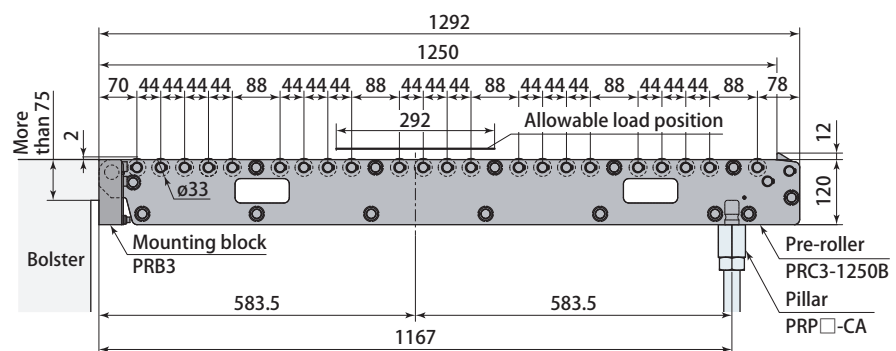

Pre-roller heavy load
PRC

Dimensions

PRC 5 – 1000 B 0300 – S

1 Die travel (mm) •.....
* Indicated in 4 digits

Pillar size •.....
* Indicated in 4 digits

1 Die travel **1000**, **1250** mm

Model		PRC5-1000B	PRC5-1250B
Die travel	mm	1000	1250
Pre-roller total length	mm	1050	1300
Weight	kg	29.8	38

PRC5-1000B□-S

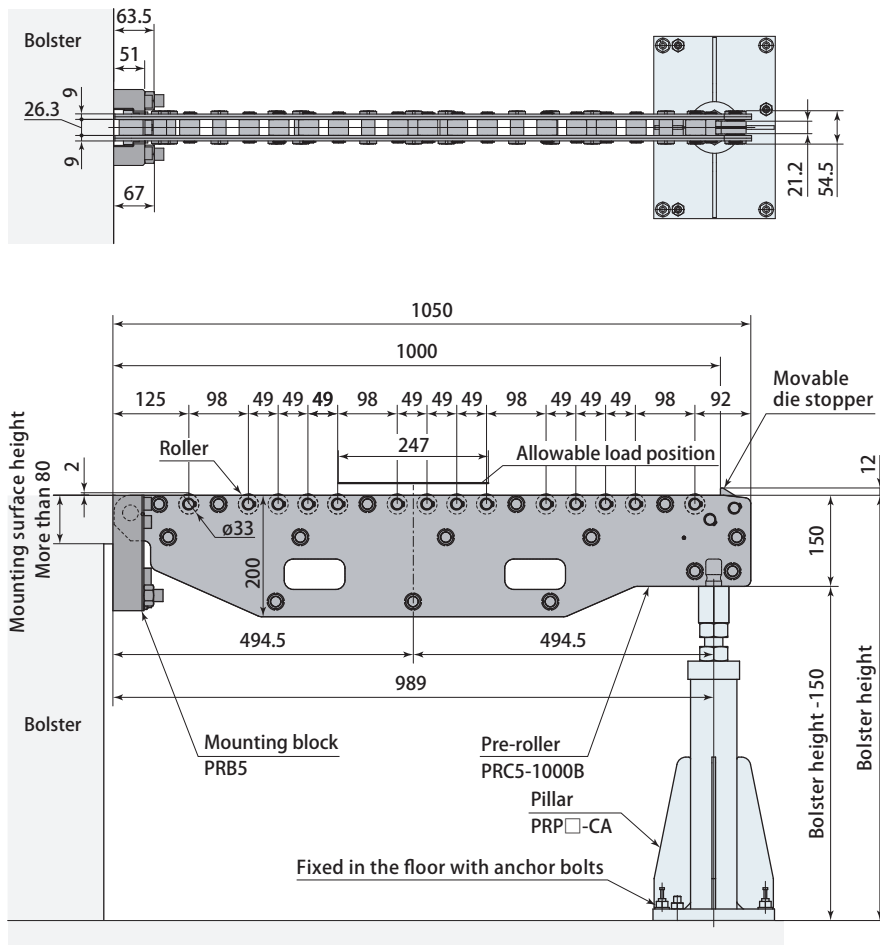

Refer to **page → 187** for Pillar.

PRC5-1250B□-S

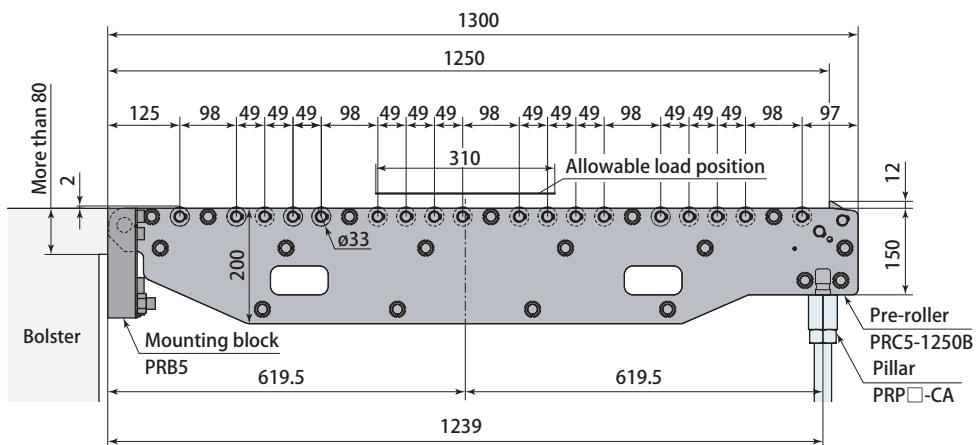

Pre-roller heavy load PRC

Dimensions, Mounting details

● When using the Die-lifter

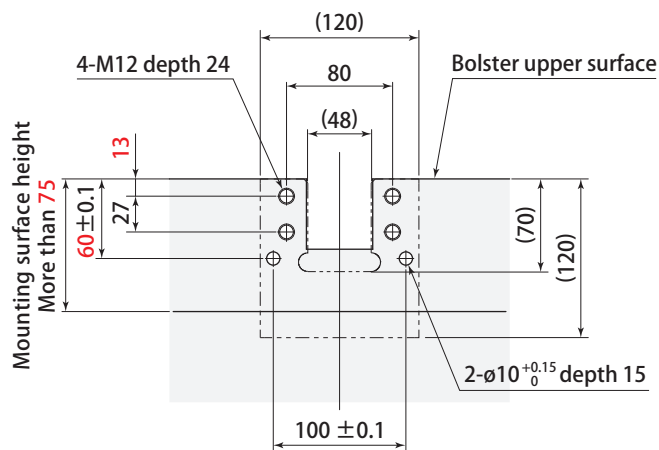
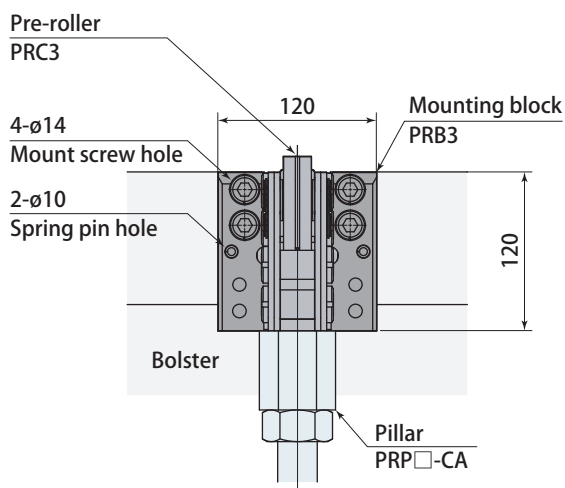

● When not using the Die-lifter

When aligning the level between roller top and bolster surface

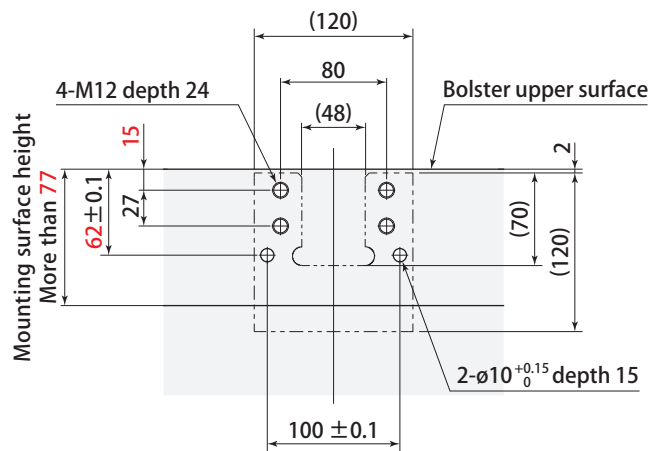
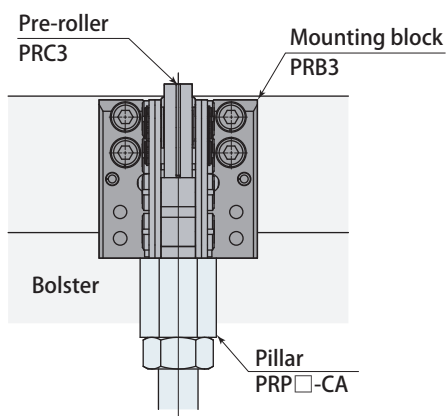

- When machining the spring pin hole, keep the tolerances shown above.
- Drill dia 10mm, 15mm deep hole for spring pin when co-machining the block with mount face.

Model	PRB3
Weight	kg 3.6
Mount screw	4-M12 length 60
Spring washer	4-M12
Spring pin	2-C10 length 56

● Mounting block for PRC3

Pre-roller heavy load
PRC Mounting details

Dimensions, Mounting details

● When using the Die-lifter

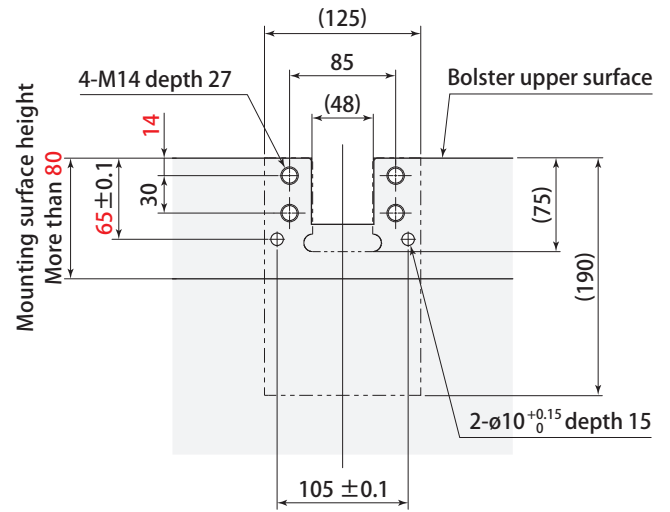
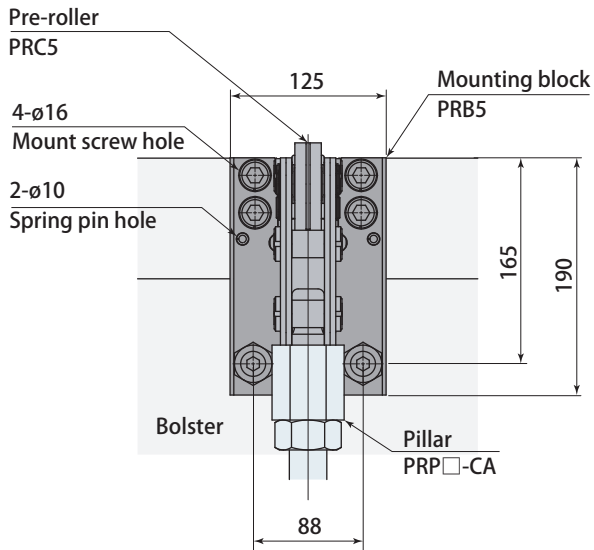

● When not using the Die-lifter

When aligning the level between roller top and bolster surface

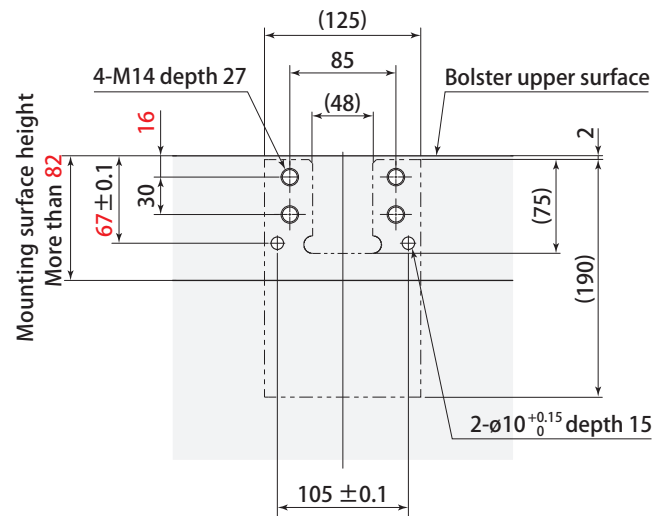
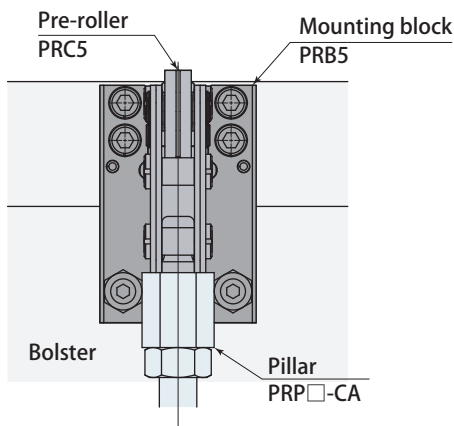

- When machining the spring pin hole, keep the tolerances shown above.
- Drill dia 10mm, 15mm deep hole for spring pin when co-machining the block with mount face.

Model	PRB5
Weight	kg 7.5
Mount screw	4-M14 length 75
Spring washer	4-M14
Spring pin	2-C10 length 63

● Mounting block for PRC5

Pillar Select Pillar for aligning the height with bolster. Pillar weight and dimension of PRC3 and PRC5 is the same.

Model designation

Pillar model type

PRP **0300** - CA

3 Pillar size
* Indicated in 4 digits

Set model

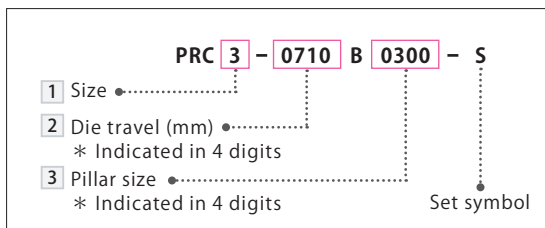

1 2
Refer to page → 180

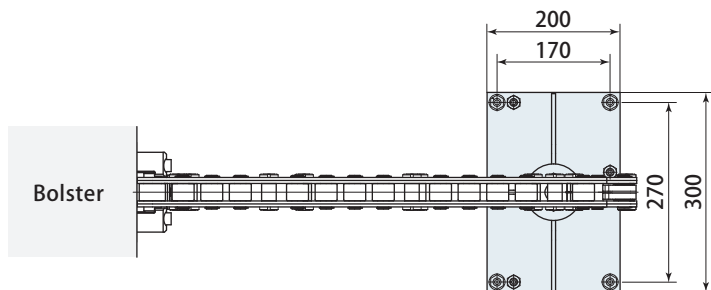

With the Adjustment bolt, Pillar height can be adjusted

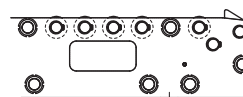
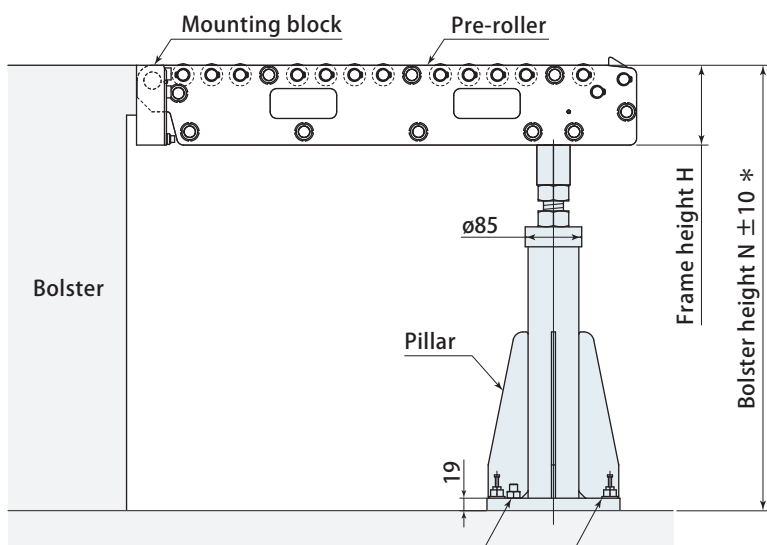

Adjustment bolt

* In order to match the difference, bolster height N can be adjusted ±10mm from the upper and lower limits.

- 3-ø10.3
- 3-M12 length 40 Level adjustment bolt
- 3-M12 Hex. Nut
- 4-ø14
- 4-C12 length 90 Strike anchor

- Adjust the Pillar horizontally using a level adjustment bolt and shim.
- The shim is not included. Order it separately.

3 Pillar size **0300** ~ **1050**

Pillar size		0300	0350	0400	0450	0500	0550	0600	0650	0700	0750	0800	0850	0900	0950	1000	1050
PRC3-0710 ~ 1250	Bolster height N mm	420 S 469	470 S 519	520 S 569	570 S 619	620 S 669	670 S 719	720 S 769	770 S 819	820 S 869	870 S 919	920 S 969	970 S 1019	1020 S 1069	1070 S 1119	1120 S 1169	1170 S 1219
	Frame height H mm	120															
PRC5-1000, 1250	Bolster height N mm	450 S 499	500 S 549	550 S 599	600 S 649	650 S 699	700 S 749	750 S 799	800 S 849	850 S 899	900 S 949	950 S 999	1000 S 1049	1050 S 1099	1100 S 1149	1150 S 1199	1200 S 1249
	Frame height H mm	150															
Weight kg		15.7	16.1	16.5	18.4	18.8	19.2	19.6	20.0	20.4	20.8	21.2	21.6	22.0	22.4	22.8	23.2

Die stopper

- When Die is pulled down on die stopper, the stopper is pushed down due to weight of die itself. When Die is pulled up, the stopper is lifted up again with spring.

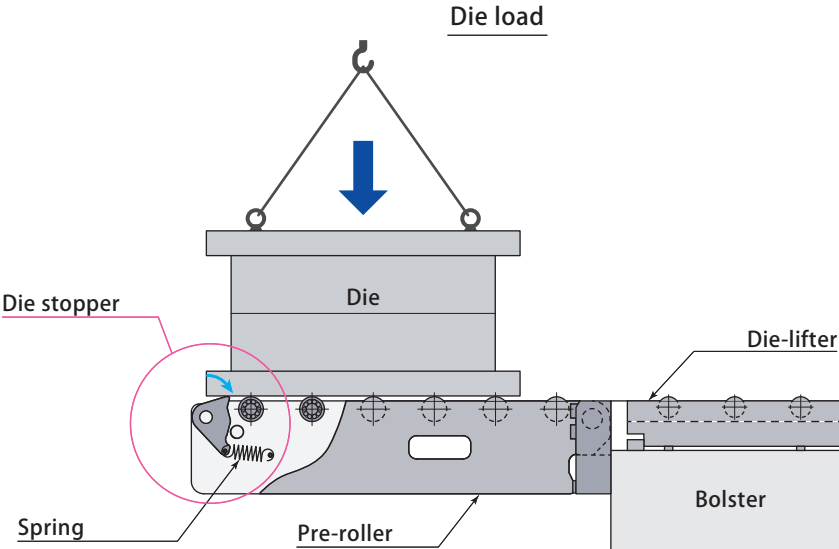

Transfer die to bolster

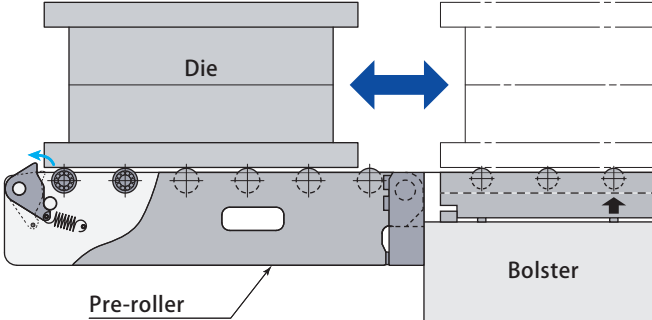

Die stopper Manual lock release lever PR□-□□BT

It is special design of pre roller due to the spring-back type of stopper as standard.

- When die is pulled up, the stopper is lifted up with spring, so select Die stopper of manual lock release lever specifications in case of unloading die by using stamping die changer.
- When changing the die with the die changer, pre-roller model PRC that contains a pillar should be selected to keep the roller level of pre-roller and the die changer the same. Model PRA, PRF and PRS/PRT are not recommended for such an application since tip of the roller arm may be sagged down due to the die weight.

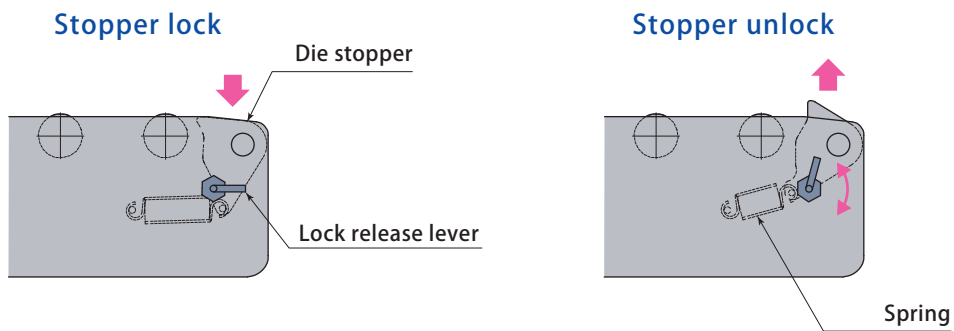
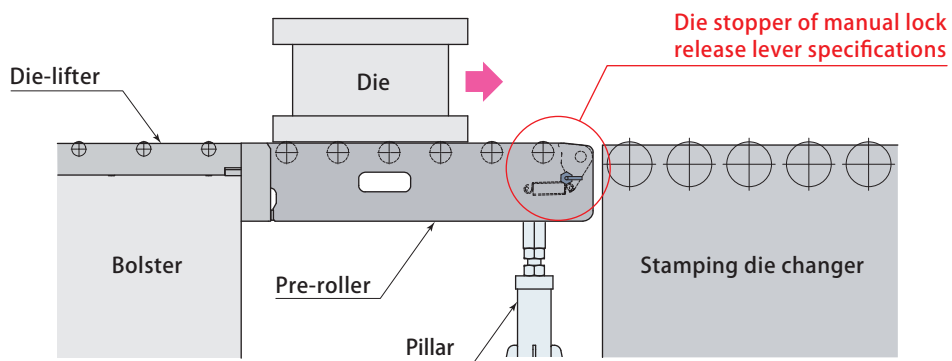

When die stopper is pushed down to the end, the pin inside lock release lever sticks out and the stopper is locked automatically.

Stopper lock is released by lifting up or down the lever.

- Contact Pascal for the details.

Mounting block

- Select mounting block for the removable type of pre-roller PRA, PRF, PRC.

Model	PRB2	PRB3	PRB5	PRB2F	PRB3F	PRB5F
Pre-roller model type	PRA2	PRA3 PRC3	PRA5 PRC5	PRF2	PRF3	PRF5

Mounting block PRB5F
(For Pre-roller PRF5)



- As the mounting block can be installed on multiple presses, a combined use on one set of Pre-rollers is possible.
- Mounting block alone can be purchased.

Caution of mounting block installation

- Make sure if the mounting block installation area is secured not to block the T-slot and die-lifter slot.
- When installation die-lifter with P or A type of stopper, be noted for the installed position so that mounting block does not interfere with T-slot and die-lifter slot.
- If the mounting block installed surface interferes with T-slot and die-lifter slot, select mounting block cut type (Refer to [page → 192](#)), or perform the additional machining on the mounting block.

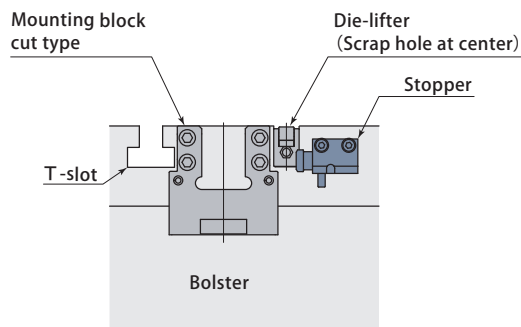

Die-lifter Scrap hole at center

It is the model that can lock or unlock the stopper and remove / insert the die-lifter.

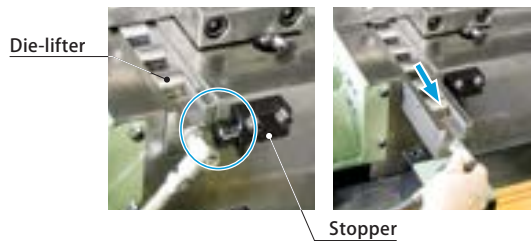

- Refer to the below specifications and mounting details of each model.

Mounting block cut type

It is applied in case that it interferes with T-slot and die-lifter slot.

Model designation

PRB 3 A

Size ●
 * Indicated in 1-2 digits
 Cut type ●

* No cut type is available for PRB2.

Mounting block cut type A

PRB3A

Pre-roller model type : PRA3

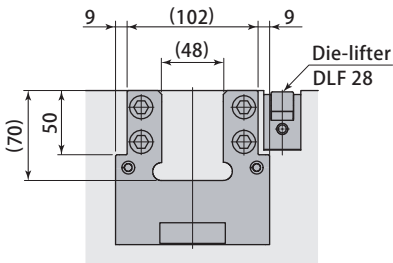

Mounting block cut type A

PRB5A

Pre-roller model type : PRA5

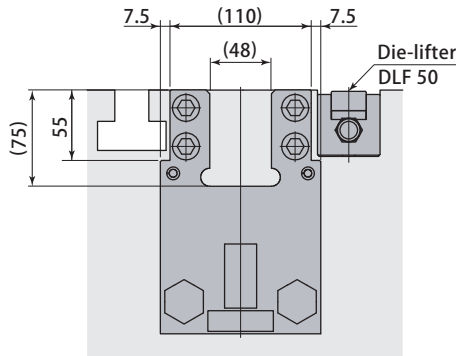

Mounting block cut type B

PRB5B

Pre-roller model type : PRA5

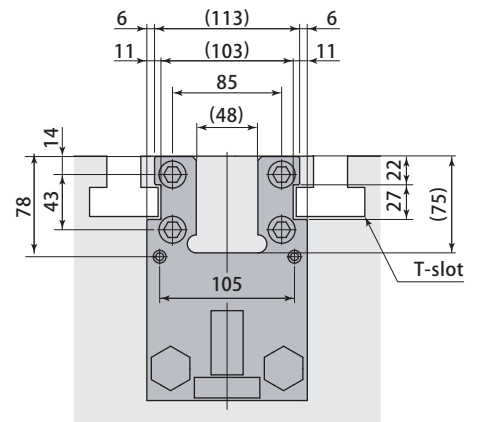

The location for mount screws and dowel pin changes.

Mounting block cut type A

PRB3FA

Pre-roller model type : PRF3

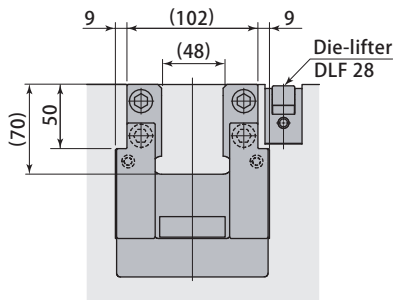

Mounting block cut type A

PRB5FA

Pre-roller model type : PRF5

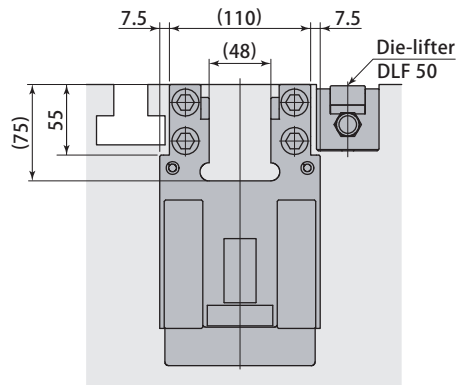

Mounting block cut type B

PRB5FB

Pre-roller model type : PRF5

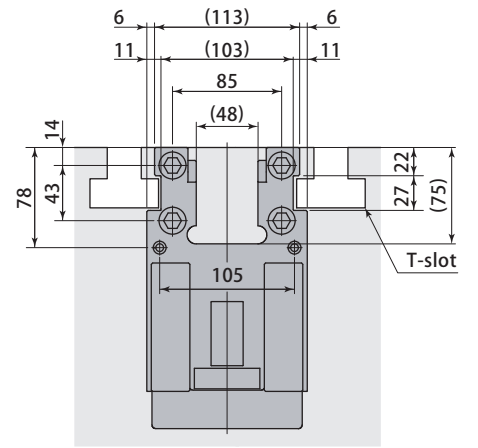

The location for mount screws and dowel pin changes.

Mounting position of Pre-roller

- Mounting position of Pre-roller varies according to the die-lifter specifications.

Die-lifter specifications	DLF28 • DLF50	When not using the Die-lifter	DLF80 • Long lifting stroke type
Mounting position of Pre-roller	Standard	Lower 2mm	Special specifications

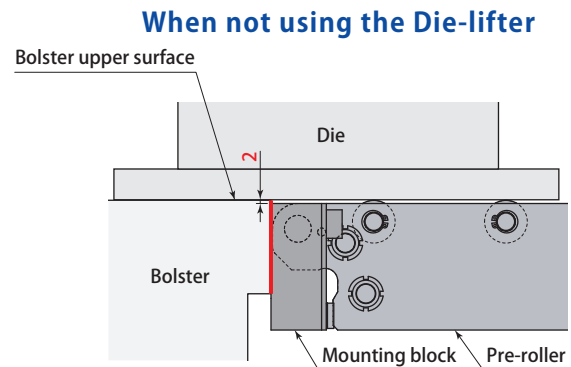
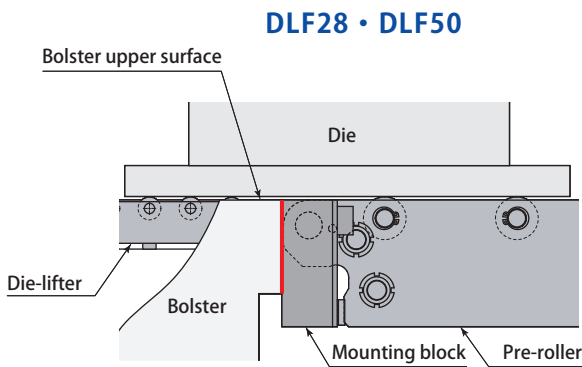

- In case no Die-lifter is used, (in case of matching the roller level and bolster), lower the mounting position 2mm.

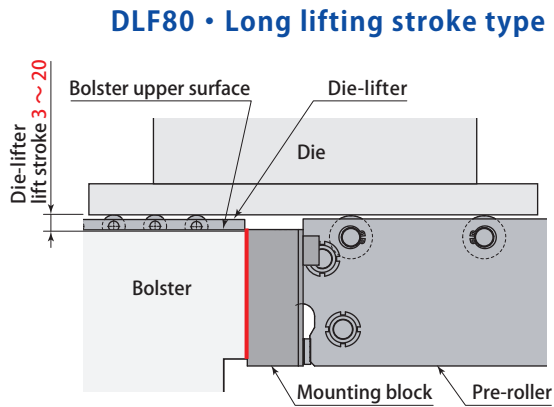

- In case that the Die-lifter is long lift stroke specifications DLF80, Pre-roller shall be a special type to match the roller level.

- Please inquire if there is a notch, hole, etc. on the underside of the die.
- Refer to the below specifications and mounting details of each model.

Die dimension

- Die dimension requires at least 3 times more than the dimension between the rollers shown below. If die dimension is small, please contact Pascal.

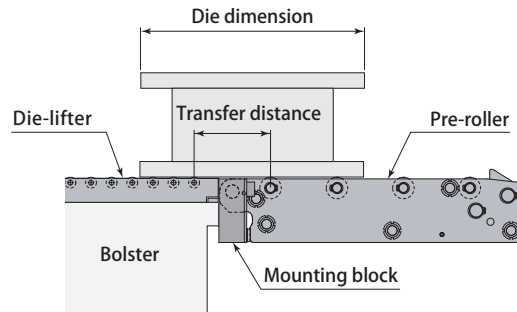

Add the extension block in the following case.

- In case that Positioning the Pre-roller and Die-lifter evenly and piping for the Die-lifter is located by the Pre-roller

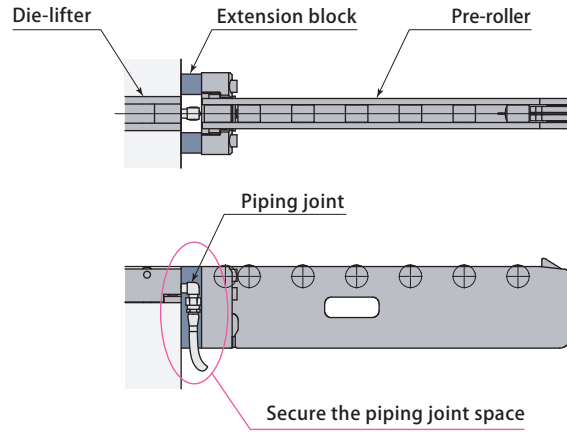

- In case that the swing type Pre-roller when folded interferes with the press machine

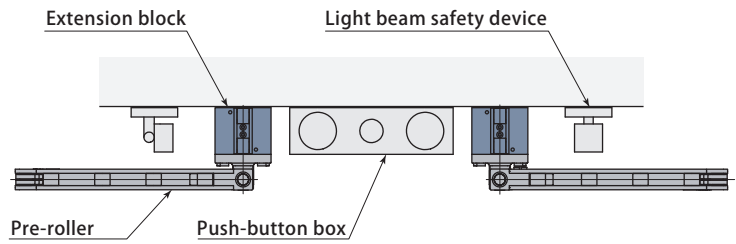

- In case that the mounting pitch can not be secured

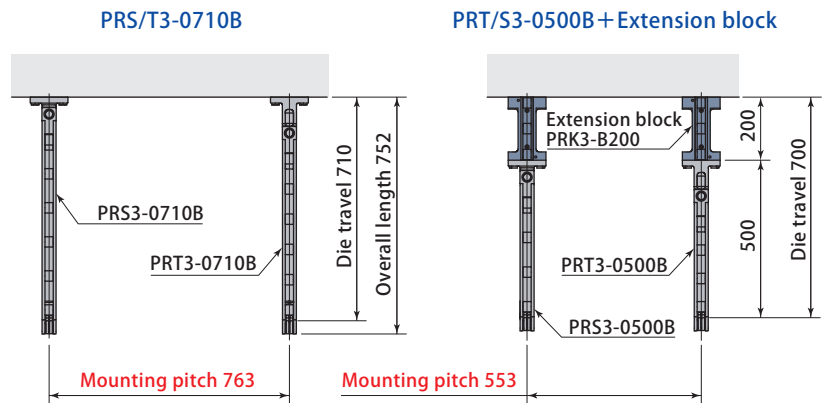

Model designation

PR J2 - A 030

- 1 Extension block model
 - 2 Die-lifter piping direction / Positioning method
 - 3 Extension block length (mm)
- * Indicated in 3 digits

1 Extension block model type

Symbol	J2	J3	J5	K3	K5	K8
Pre-roller model type	PRA 2 PRF 2	PRA 3 PRF 3 PRC 3	PRA 5 PRF 5 PRC 5	PRS3/PRT3	PRS5/PRT5	PRS 8/PRT 8

2 Die-lifter piping direction / Positioning method

Symbol	A	B	C	D
Die-lifter piping direction Positioning method	Front piping with spring pin hole	Rear piping with spring pin hole	Front piping without spring pin hole	Rear piping without spring pin hole

● There is no method for 30mm long block without spring hole.

Die-lifter: Front piping
(When piping is on the Pre-roller side)

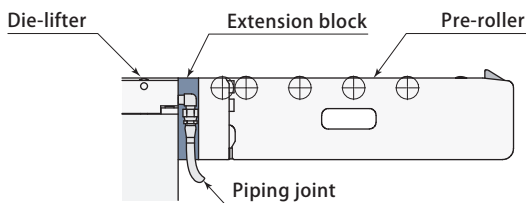

Die-lifter: Rear piping

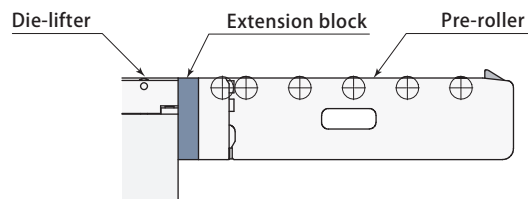

With spring pin hole

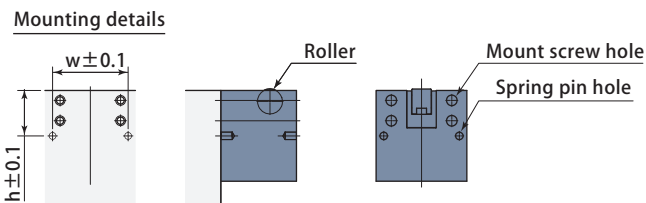

Pre-roller's mounting position cannot be adjusted.
Machine mounting surface of extension block on the press side.

Without spring pin hole

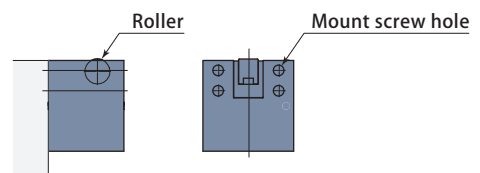

Determine the positioning for extension block and Pre-roller by co-machining one-side after installation.

3 Extension block length

Extension block length							mm
030	050	100	150	200	250	300	

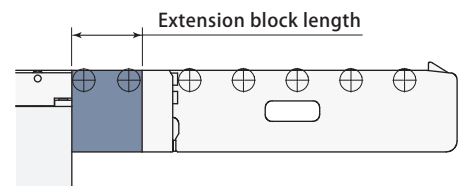

- The shape of extension block varies according to extension block model and size, Die-lifter piping direction and block length.

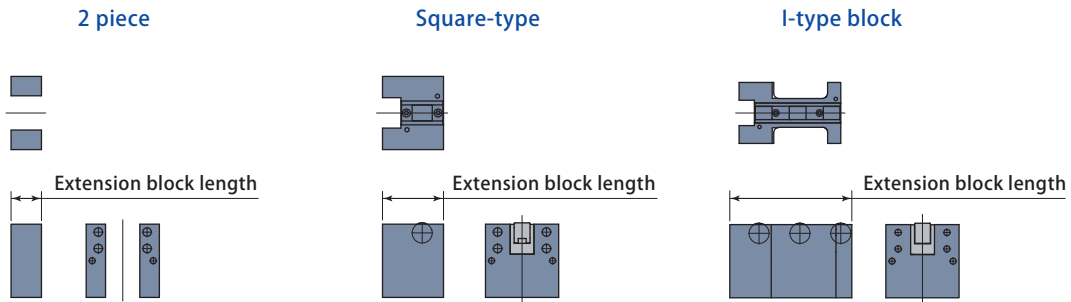

Extension block model (Model, Size)	PRJ2-A PRJ2-C	PRJ2-B PRJ2-D	PRJ 3-A PRJ 3-C PRK3-A PRK3-C	PRJ 3-B PRJ 3-D PRK3-B PRK3-D	PRJ 5-A PRJ 5-C PRK5-A PRK5-C	PRJ 5-B PRJ 5-D PRK5-B PRK5-D	PRK8-A PRK8-C	PRK8-B PRK8-D
Pre-roller model type (Model, Size)	PRA 2 PRF 2		PRA 3 PRF 3 PRC 3 PRS3/PRT3		PRA 5 PRF 5 PRC 5 PRS5/PRT5		PRS 8/PRT 8	
Die-lifter piping direction	Front piping	Rear piping	Front piping	Rear piping	Front piping	Rear piping	Front piping	Rear piping
Extension block length	030	2 piece	2 piece	2 piece	2 piece	2 piece	2 piece	2 piece
	050							
	100	Square-type block	Square-type block	Square-type block	Square-type block	Square-type block	Square-type block	
	150	Square-type block	Square-type block	Square-type block	Square-type block	Square-type block	Square-type block	
	200	I-type block	I-type block	I-type block	I-type block	I-type block	I-type block	I-type block
	250							
	300							

- Mount screw size for I-type block
PRJ2/PRJ3/PRK3:M14 PRJ5/PRK5:M16 PRK8:M20
- Allowable load changes according to the die travel dimension. Contact Pascal for the details.

Pre-roller stand

model **PRM**

It can be carried in front of the machine and be easily mount/dismount by using an overhead crane, a forklift and a hand pallet truck thereby 1 set of pre-roller stand is applicable for multiple press machines.



Realizing safer die change operation

Recommended for the die weighing over 2 tons.

In case the die weight is 8 ton

Conventional

new

Pre-roller (PRC)

Die change : 180min.
Operators : 3persons



Pre-roller stand

Die change : 45min.
Operators : 2persons

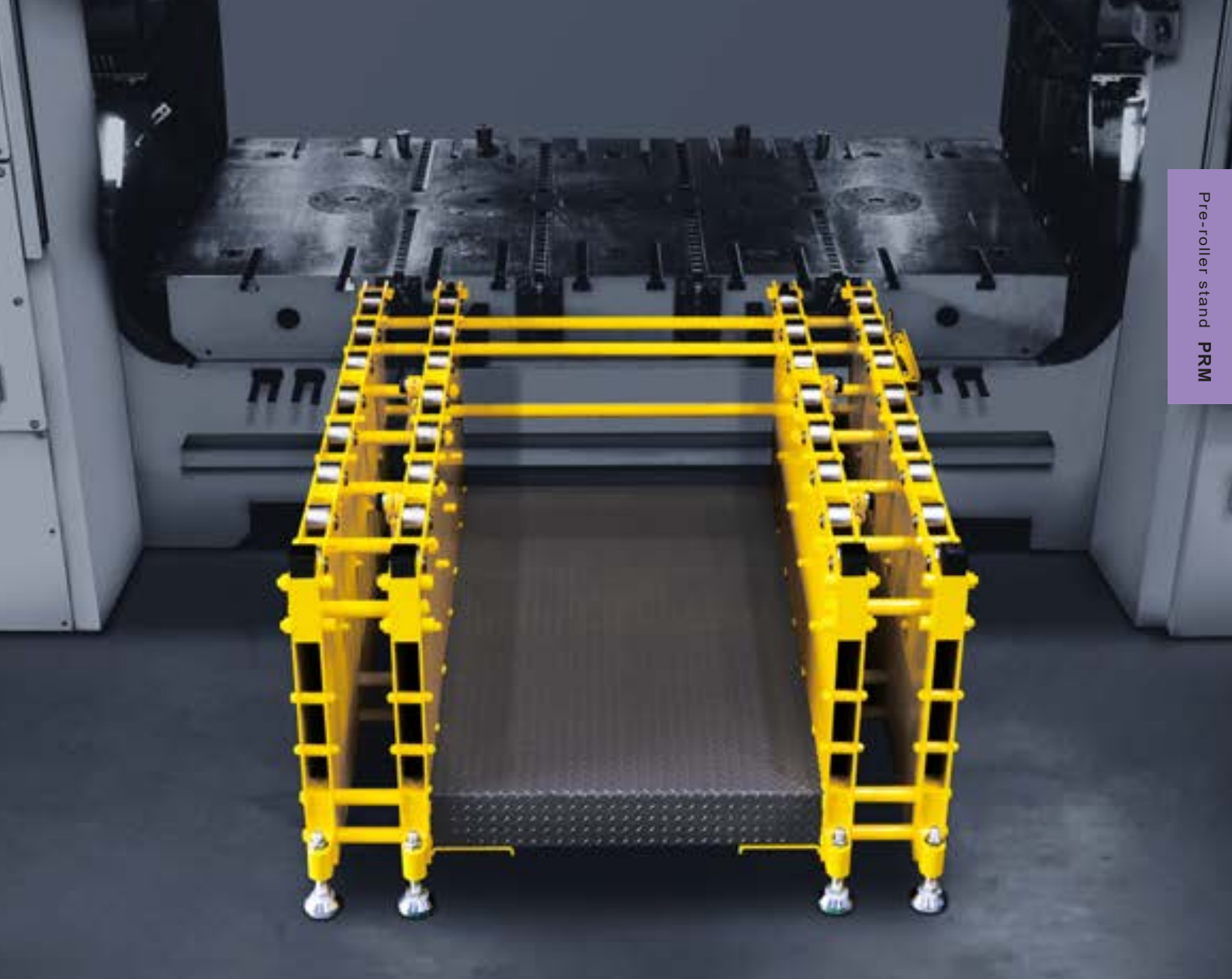

We are delivering videos on the Internet



6,000kN press machine 2ton
The loding/unloadng of die



20,000kN press machine 8ton
The loding/unloadng of die



It has more excellent rigidity compared with pre-roller and there is very little displacement under the load so that the loading/unloading the die can be smoothly performed.



Specifications

Model		PRM1-1250	PRM2-1250	PRM1-1600	PRM2-1600	PRM1-2000	PRM2-2000
Roller frame pitch	mm	600 ~ 1600		600 ~ 1600		600 ~ 1600	
Die travel	mm	1250		1600		2000	
Overall length of pre-roller stand	mm	1300		1650		2050	
Mass	kg	430 ※ 1	640 ※ 2	520 ※ 1	770 ※ 2	680 ※ 1	940 ※ 2
Max. allowable load	kN(ton)	80 (8)		80 (8)		80 (8)	
Quantity of rollers		12	24	16	32	20	40
Bolster height	mm	500 ~ 1300		500 ~ 1300		500 ~ 1300	

● Die loading speed on Pre-roller : Less than 50mm/s ● Die transfer speed : Less than 100mm/s

※1 Roller frame pitch for 1000mm, Bolster height 700mm. The mass of the bolster mounting block is not included.

※2 Roller frame pitch for 1000mm, 1400mm, Bolster height 700mm. The mass of the bolster mounting block is not included.

Model designation

PRM **1** - **1250**

1 Number of roller frames •.....

PRM **1** : 2-rows PRM **2** : 4-rows

2 Die travel (mm) * Indicated in 4 digits •.....

1250 : 1250 mm **1600** : 1600 mm **2000** : 2000 mm

● Specify bolter height and distance between the roller frame.

Selection criteria

In case the die weight is over 2ton, die width is over 1300mm and die travel is over 1250mm, pre-roller stand is recommendable.

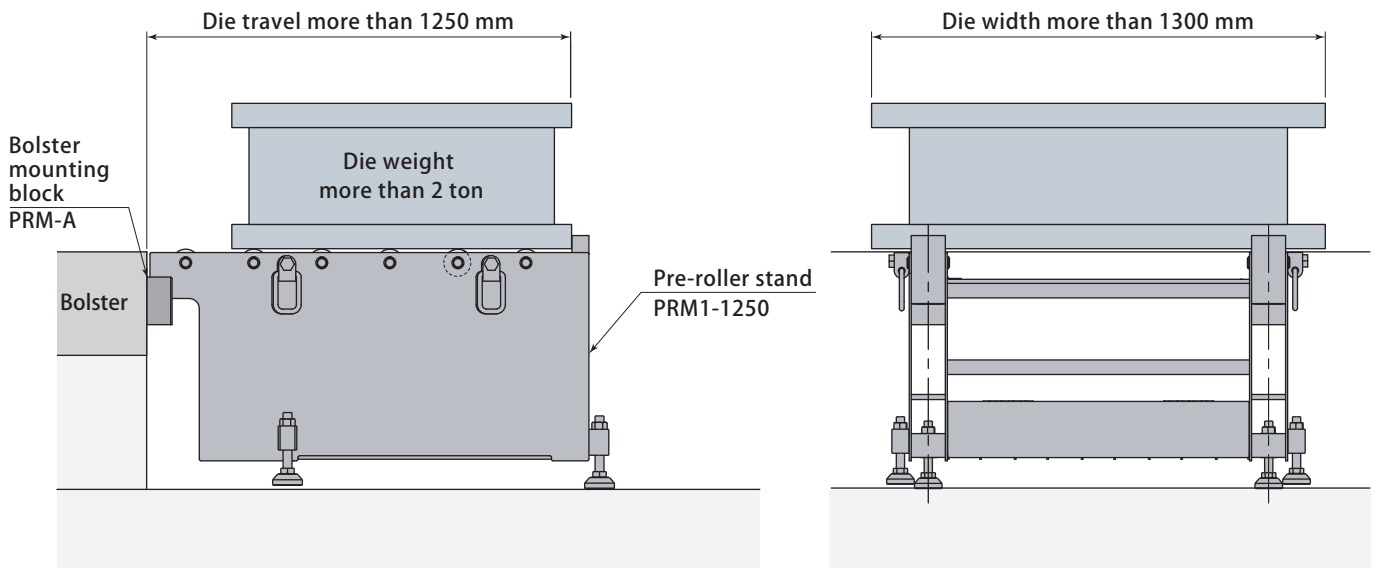

Rollers are hardly damaged when placing a die and smooth loading of die is maintainable for a long period as the durability has been enhanced by strong structures. By introducing a rigid structure with durable rollers and more resistant to impact when placing a die, smooth die transfer is maintainable for long period of time.

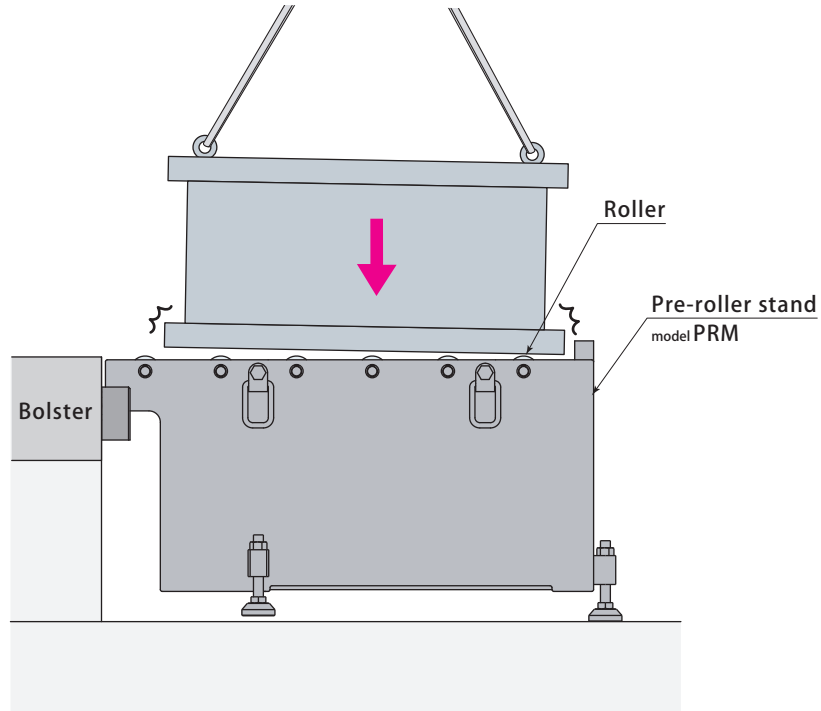

Larger diameter of rollers are adopted to load/unload a die smoothly.

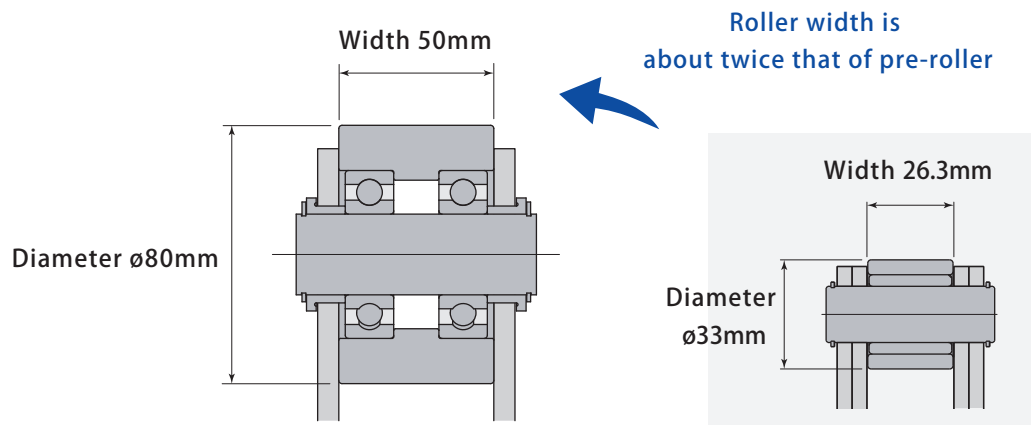

Easy to carry and mount. It takes less time to install and remove.



Die travel : less than 1250mm
Carry and mount by hand pallet truck

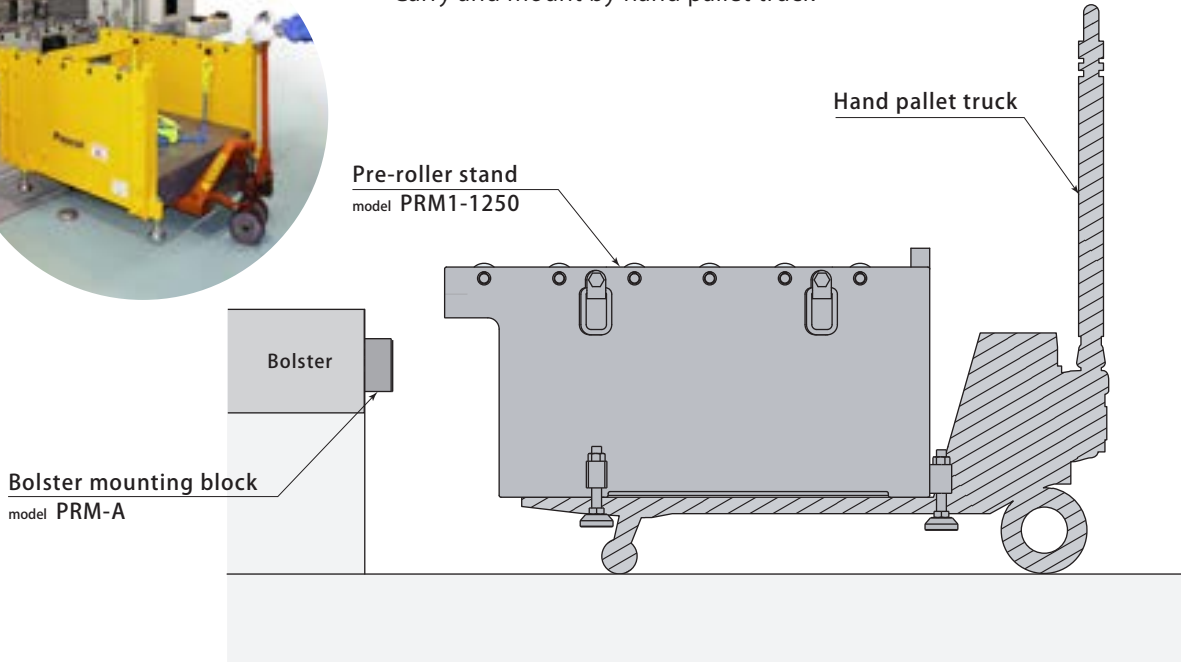

Die travel : 1600mm, 2000mm
Carry and mount by overhead crane*

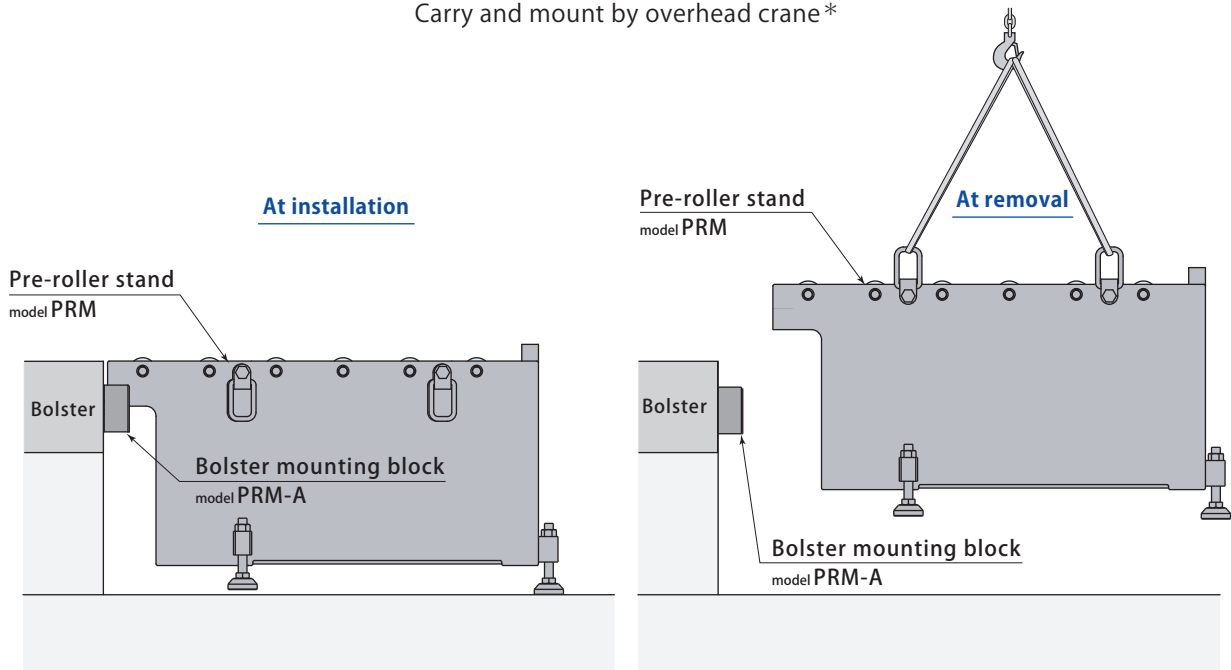

* A hand pallet truck (with 1510mm-long fork) is also useful to carry or mount.

PRM 1 - 1250

- 1 Number of roller frames
PRM1 : 2-rows PRM2 : 4-rows
- 2 Die travel (mm)
* Indicated in 4 digits

Model		PRM1-1250
Roller frame pitch	mm	600 ~ 1600
Die travel	mm	1250
Overall length of pre-roller stand	mm	1300
Mass ※1	kg	430
Max. allowable load	kN(ton)	80(8)
Quantity of rollers		12
Bolster height	mm	500 ~ 1300

※1 Roller frame pitch for 1000mm, Bolster height 700mm. The mass of the bolster mounting block is not included.

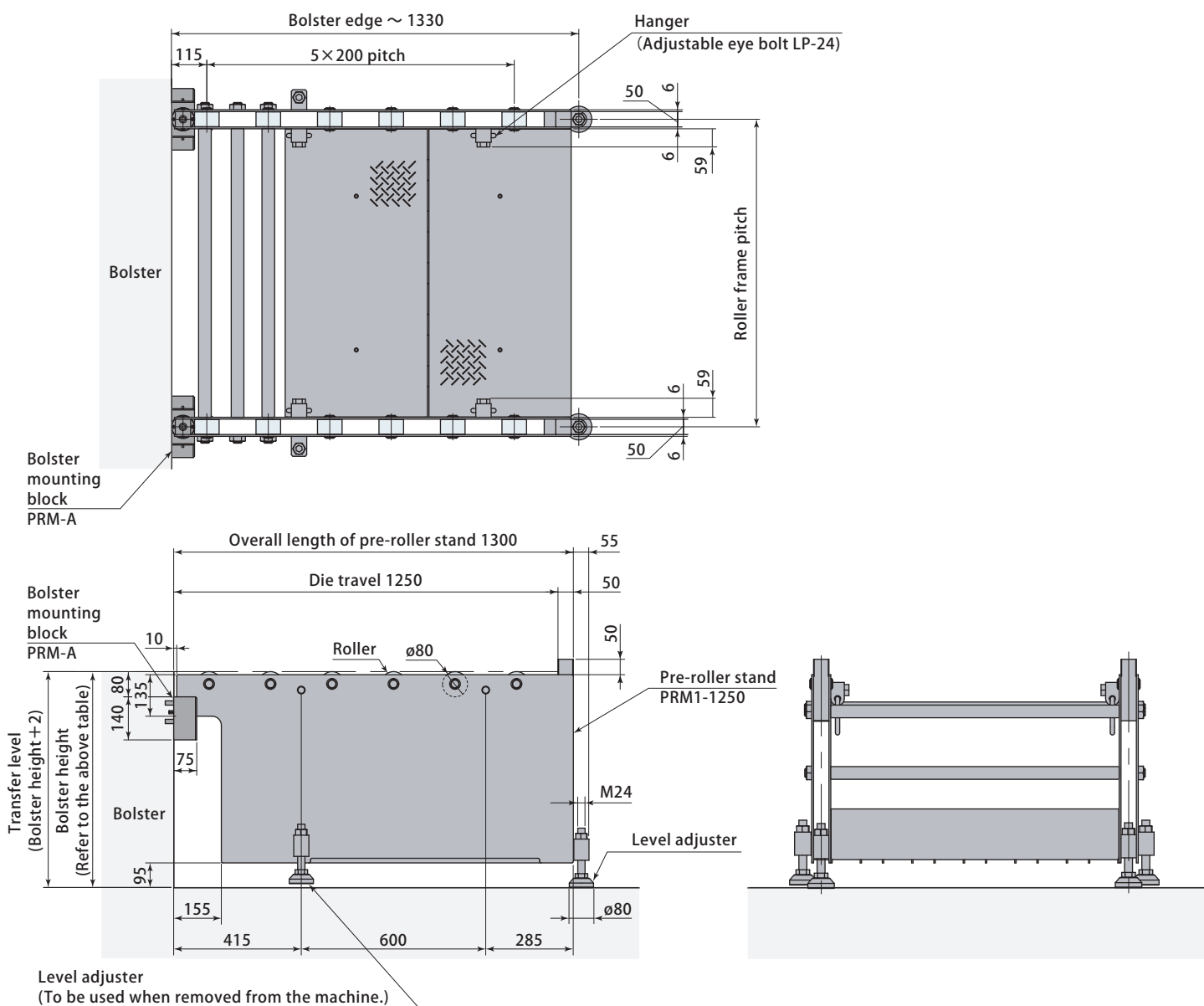

PRM 2 - 1250

- 1 Number of roller frames
PRM1 : 2-rows PRM2 : 4-rows
- 2 Die travel (mm)
* Indicated in 4 digits

Model		PRM2-1250
Roller frame pitch	mm	600 ~ 1600
Die travel	mm	1250
Overall length of pre-roller stand	mm	1300
Mass ※1	kg	640
Max. allowable load	kN(ton)	80(8)
Quantity of rollers		24
Bolster height	mm	500 ~ 1300

※1 Roller frame pitch for 1000mm, 1400mm, Bolster height 700mm. The mass of the bolster mounting block is not included.

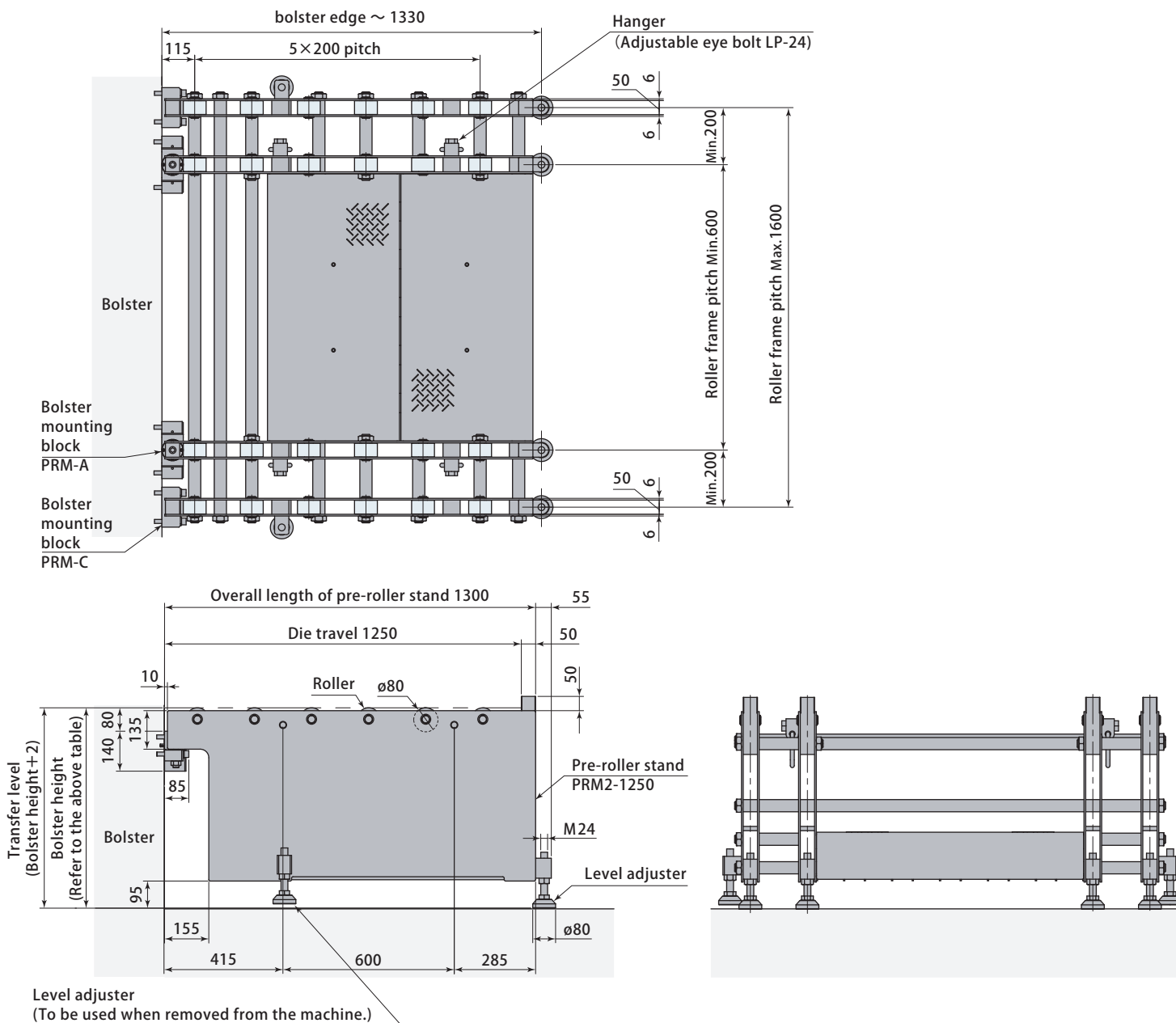

PRM 1 - 1600

- 1 Number of roller frames •.....
PRM1 : 2-rows PRM2 : 4-rows
- 2 Die travel (mm) •.....
* Indicated in 4 digits

Model		PRM1-1600
Roller frame pitch	mm	600 ~ 1600
Die travel	mm	1600
Overall length of pre-roller stand	mm	1650
Mass ※1	kg	520
Max. allowable load	kN(ton)	80(8)
Quantity of rollers		16
Bolster height	mm	500 ~ 1300

※1 Roller frame pitch for 1000mm, Bolster height 700mm. The mass of the bolster mounting block is not included.

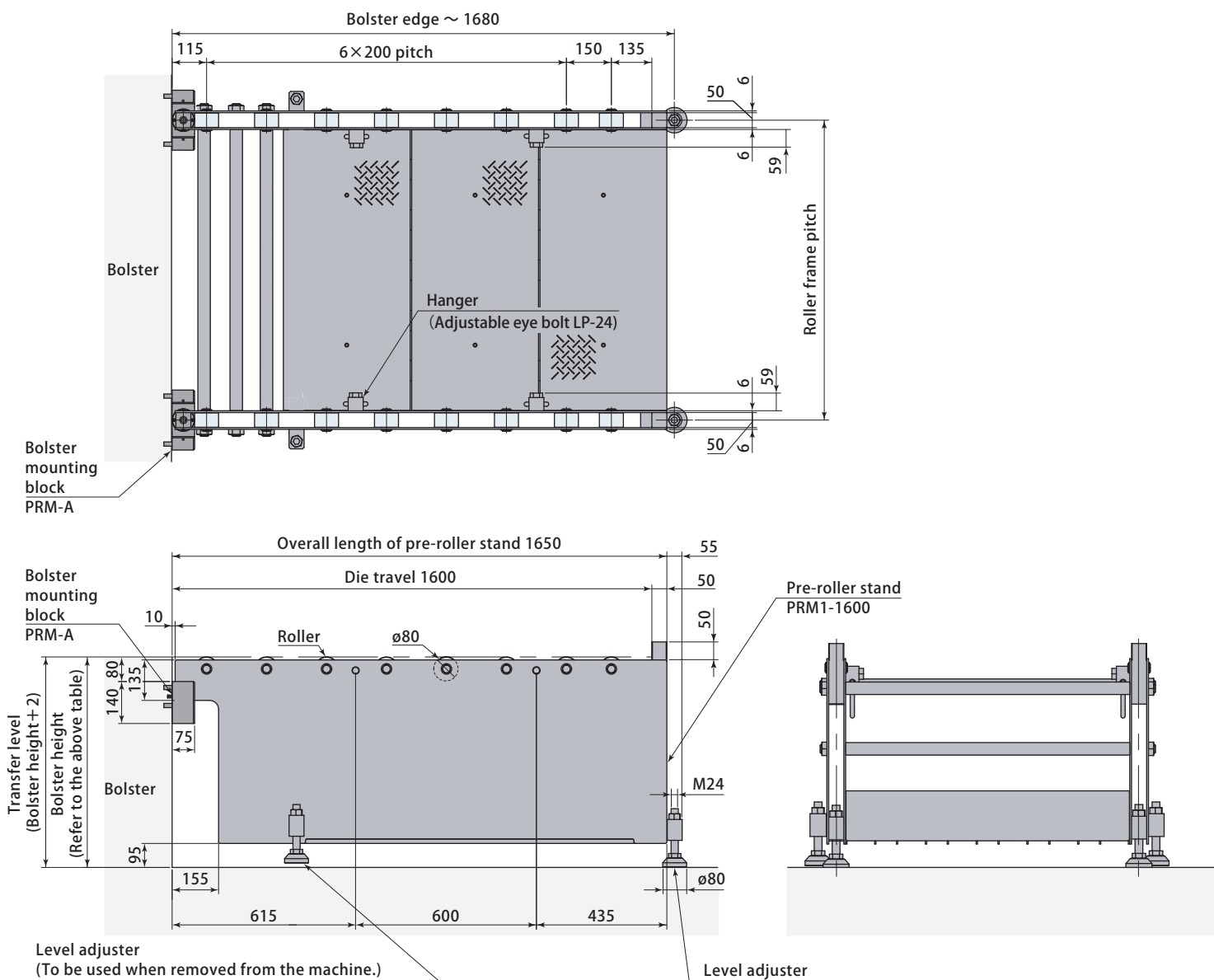

PRM 2 - 1600

- 1 Number of roller frames ●.....
PRM1 : 2-rows PRM2 : 4-rows
- 2 Die travel (mm) ●.....
* Indicated in 4 digits

Model		PRM2-1600
Roller frame pitch	mm	600 ~ 1600
Die travel	mm	1600
Overall length of pre-roller stand	mm	1650
Mass ※1	kg	770
Max. allowable load	kN(ton)	80(8)
Quantity of rollers		32
Bolster height	mm	500 ~ 1300

※1 Roller frame pitch for 1000mm, 1400mm, Bolster height 700mm. The mass of the bolster mounting block is not included.

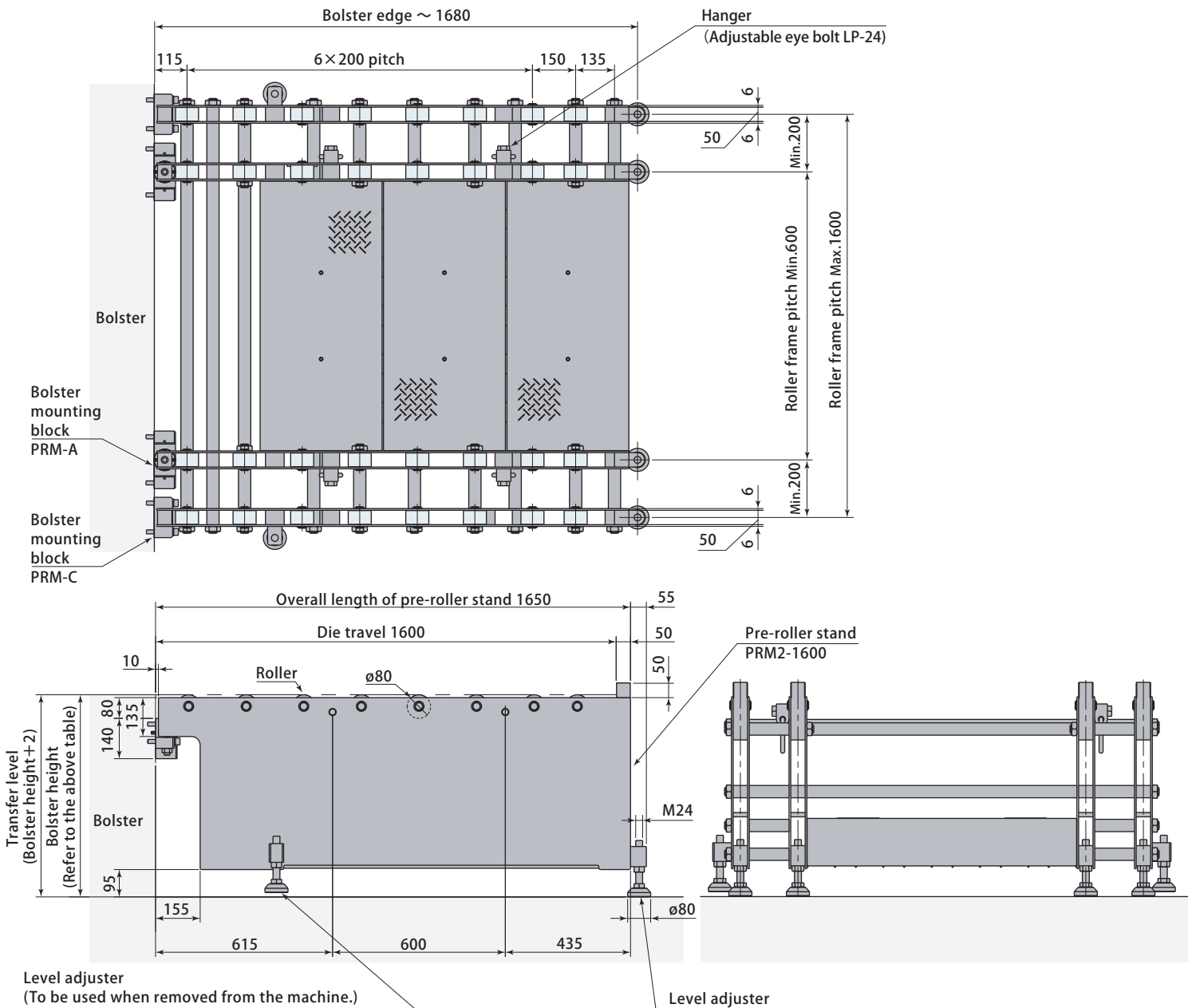

PRM 1 - 2000

- 1 Number of roller frames
PRM1 : 2-rows PRM2 : 4-rows
- 2 Die travel (mm)
* Indicated in 4 digits

Model		PRM1-2000
Roller frame pitch	mm	600 ~ 1600
Die travel	mm	2000
Overall length of pre-roller stand	mm	2050
Mass ※1	kg	680
Max. allowable load	kN(ton)	80(8)
Quantity of rollers		20
Bolster height	mm	500 ~ 1300

※1 Roller frame pitch for 1000mm, Bolster height 700mm. The mass of the bolster mounting block is not included.

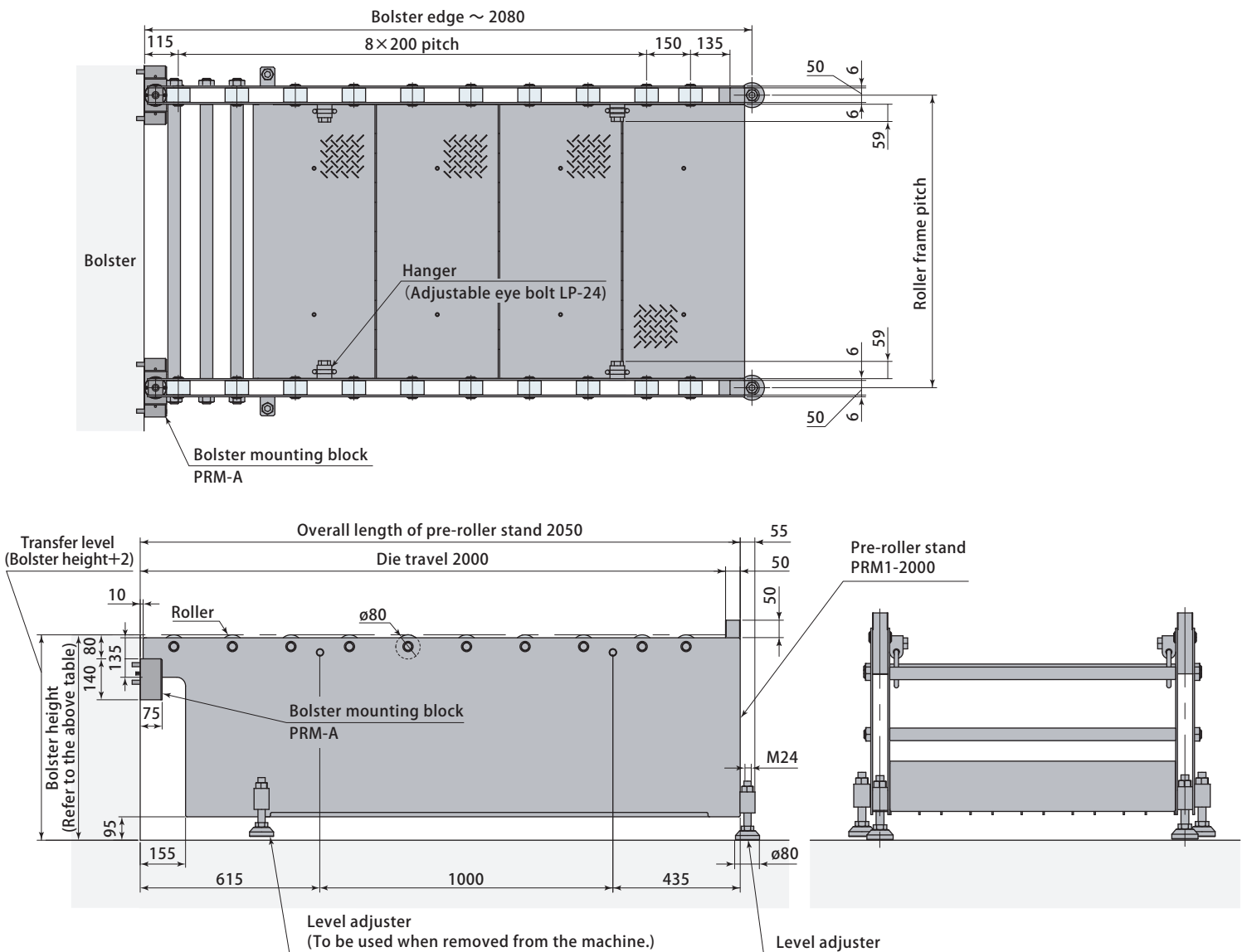

PRM 2 - 2000

- 1 Number of roller frames
 - PRM1 : 2-rows
 - PRM2 : 4-rows
- 2 Die travel (mm)
 - * Indicated in 4 digits

Model		PRM2-2000
Roller frame pitch	mm	600 ~ 1600
Die travel	mm	2000
Overall length of pre-roller stand	mm	2050
Mass ※1	kg	940
Max. allowable load	kN(ton)	80(8)
Quantity of rollers		40
Bolster height	mm	500 ~ 1300

※1 Roller frame pitch for 1000mm, 1400mm, Bolster height 700mm. The mass of the bolster mounting block is not included.

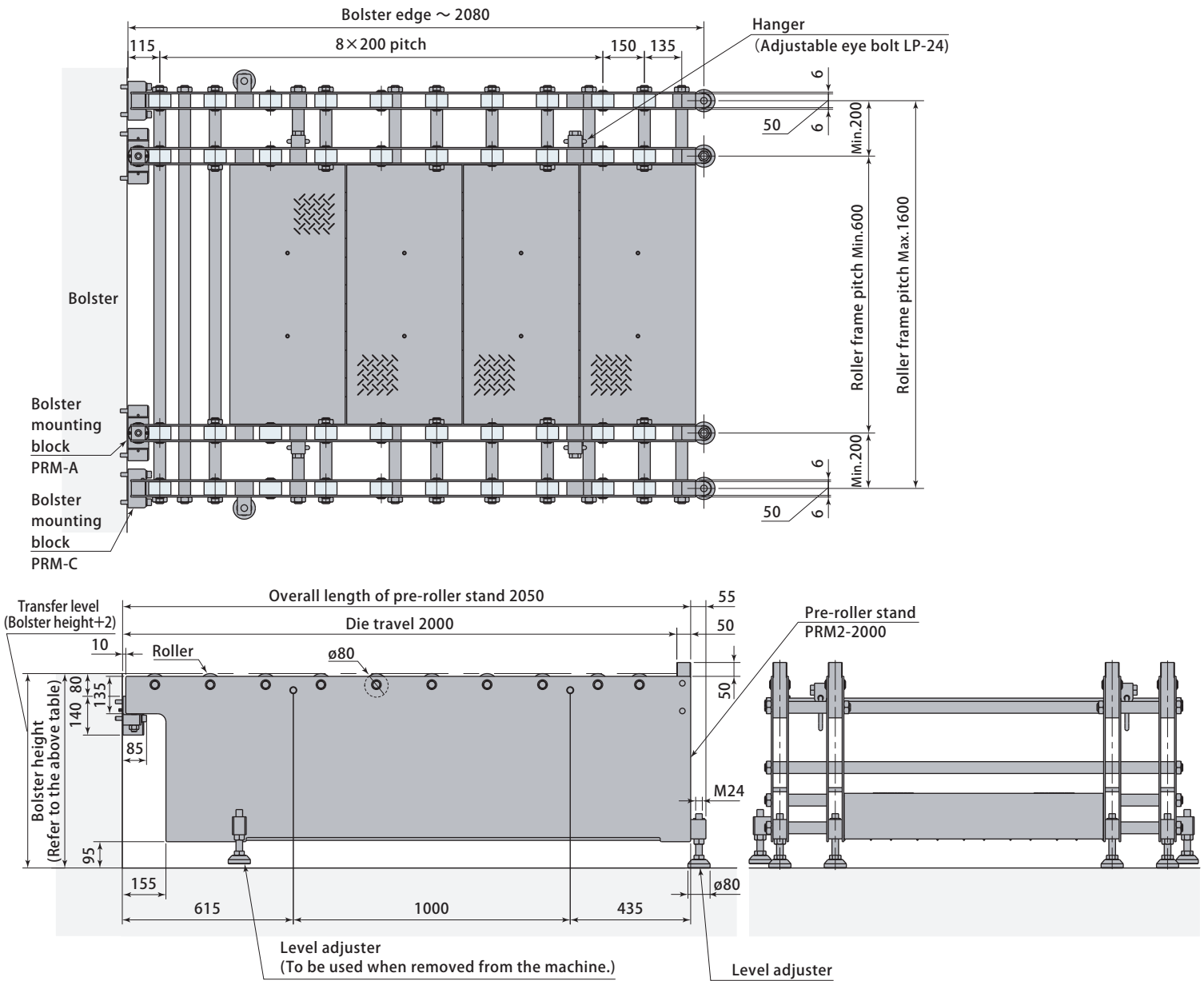

PRM-A

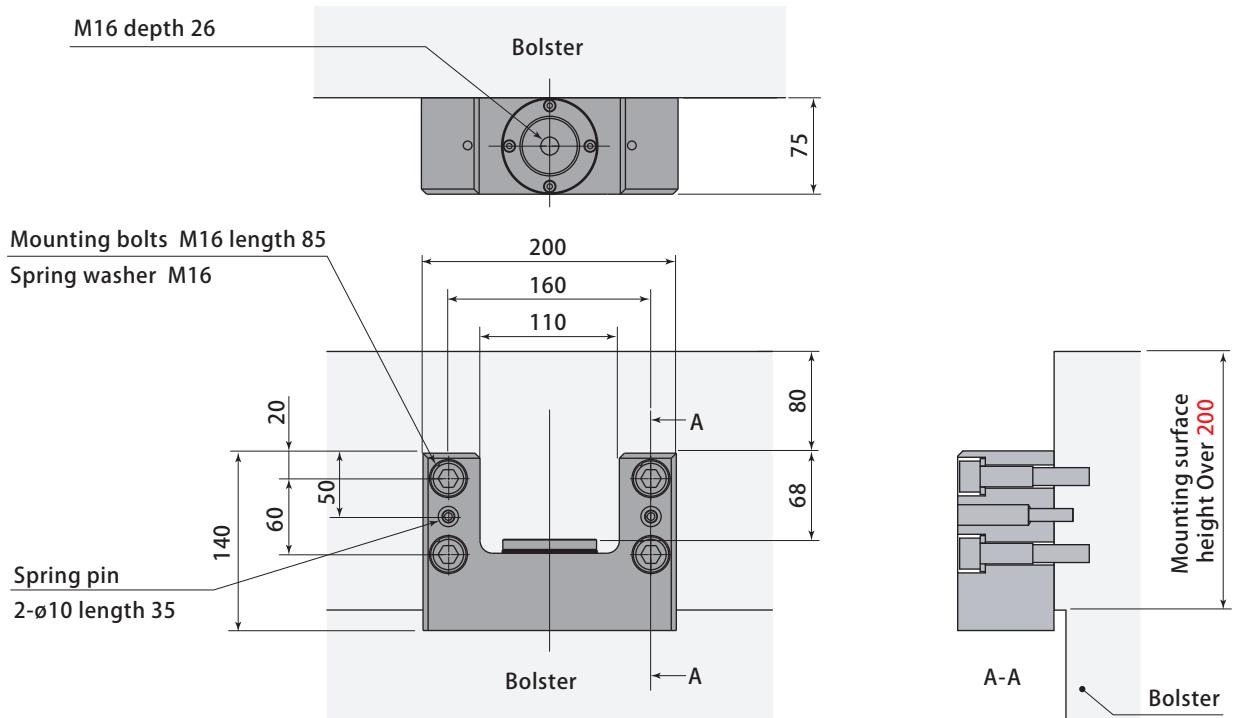

PRM-C

For 4 rows (With PRM-A)

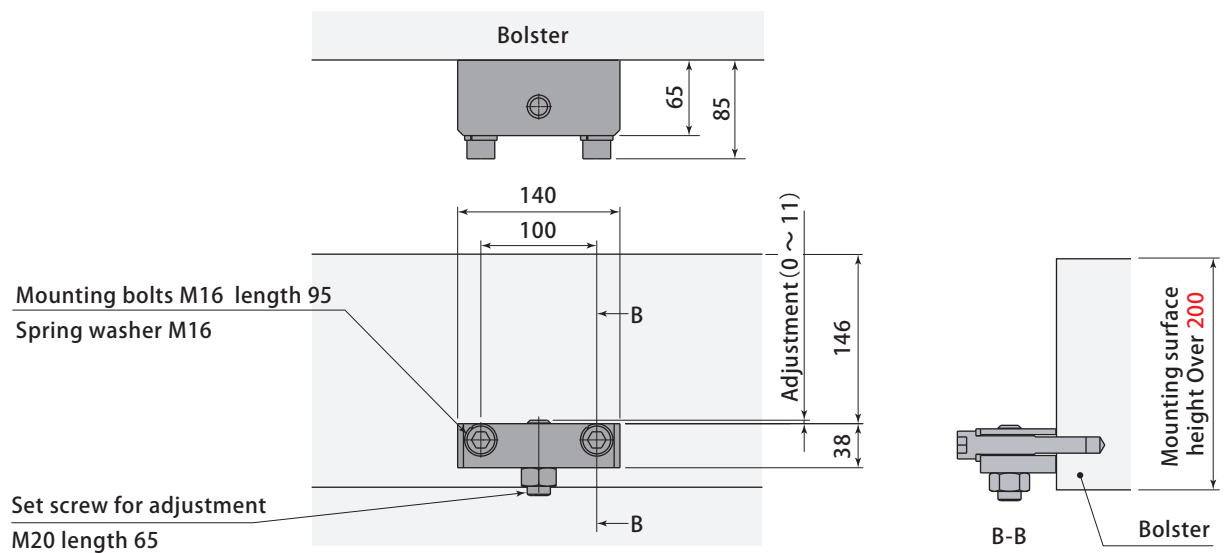

Model	PRM-A	PRM-C
Mass	13	3
Mounting bolts	4-M16 length 85	2-M16 length 95
Spring pin	2- ϕ 10 length 35	-
Set screw for adjustment	-	1-M20 length 65

Use this block when Die lifter piping runs block mounting area.

with piping pocket
PRM-A-30

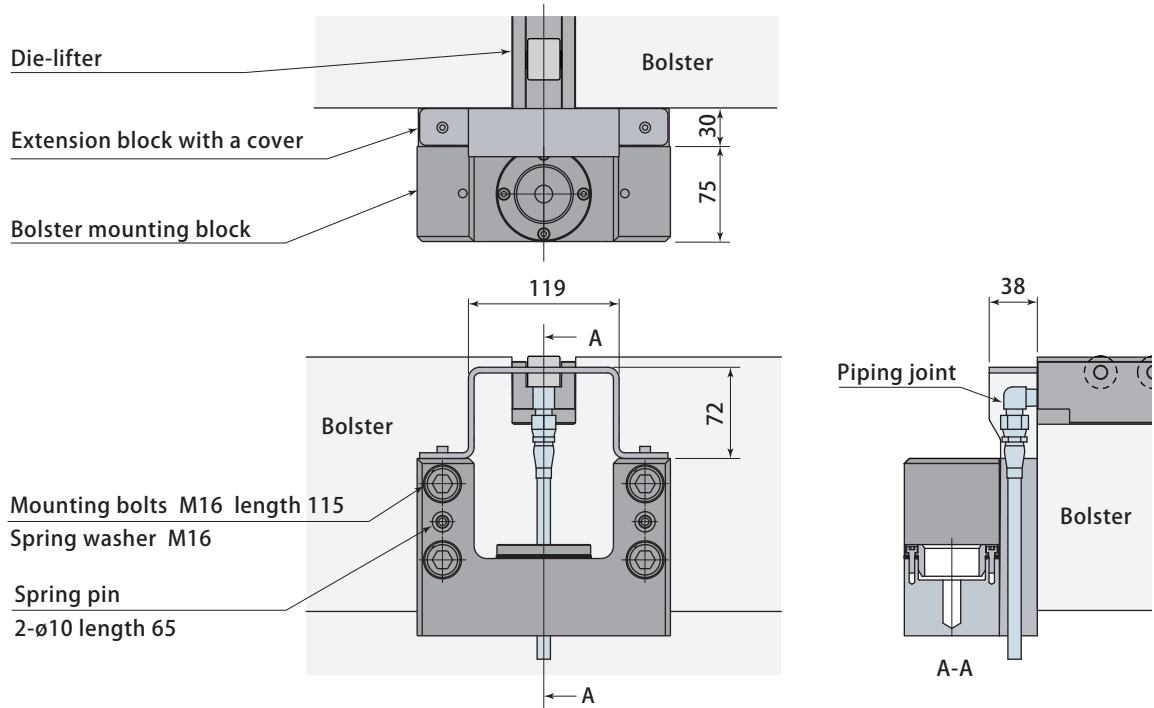

with piping pocket
PRM-C-30

For 4 rows (With PRM-A)

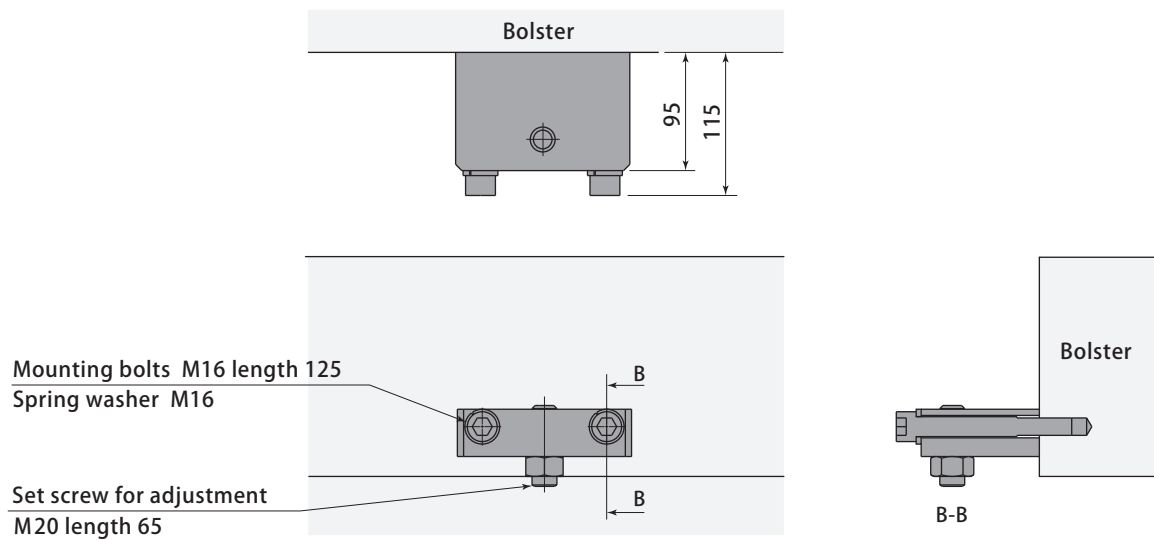

※ Refer to PRM-A, PRM-C diagram for other dimensions which are not shown.

Model	PRM-A-30	PRM-C-30
Mass	15.6	4.2
Mounting bolts	4-M16 length 115	2-M16 length 125
Spring pin	2- ϕ 10 length 65	-
Set screw for adjustment	-	1-M20 length 65

Mounting Details

PRM-A / PRM-A-30

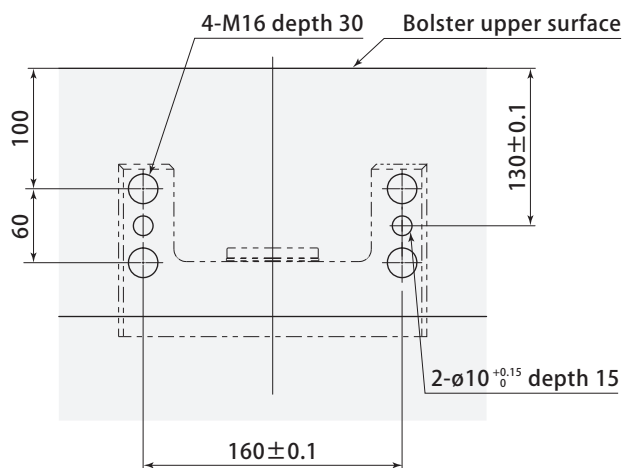

PRM-C / PRM-C-30

For 4 rows (With PRM-A)

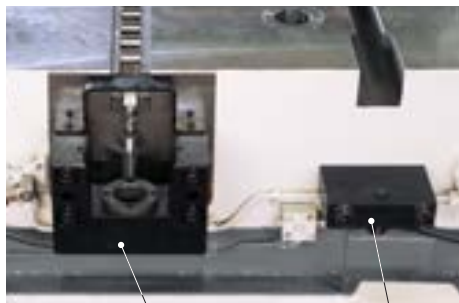

PRM-A-30

PRM-C-30

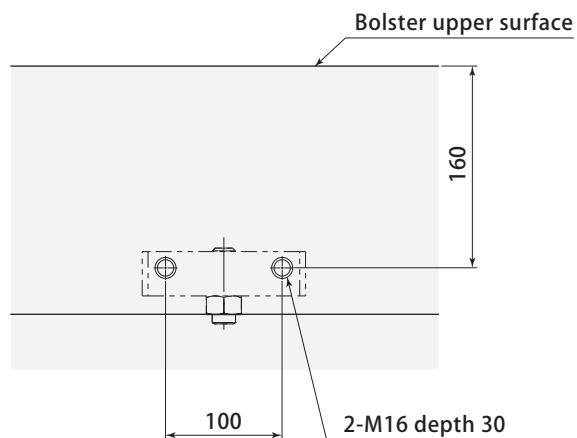

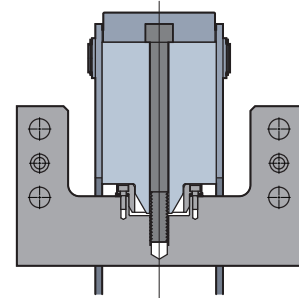
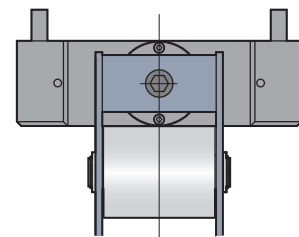
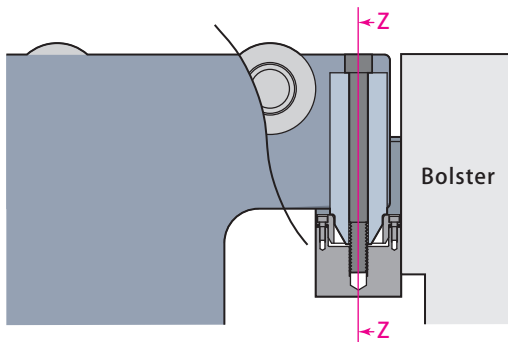
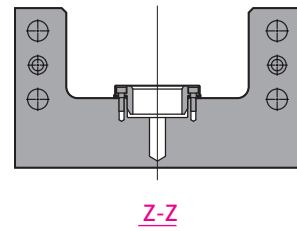
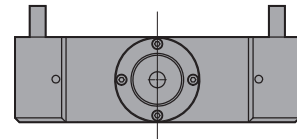
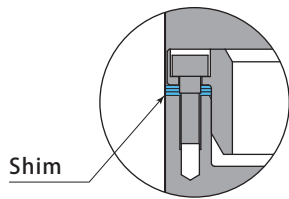
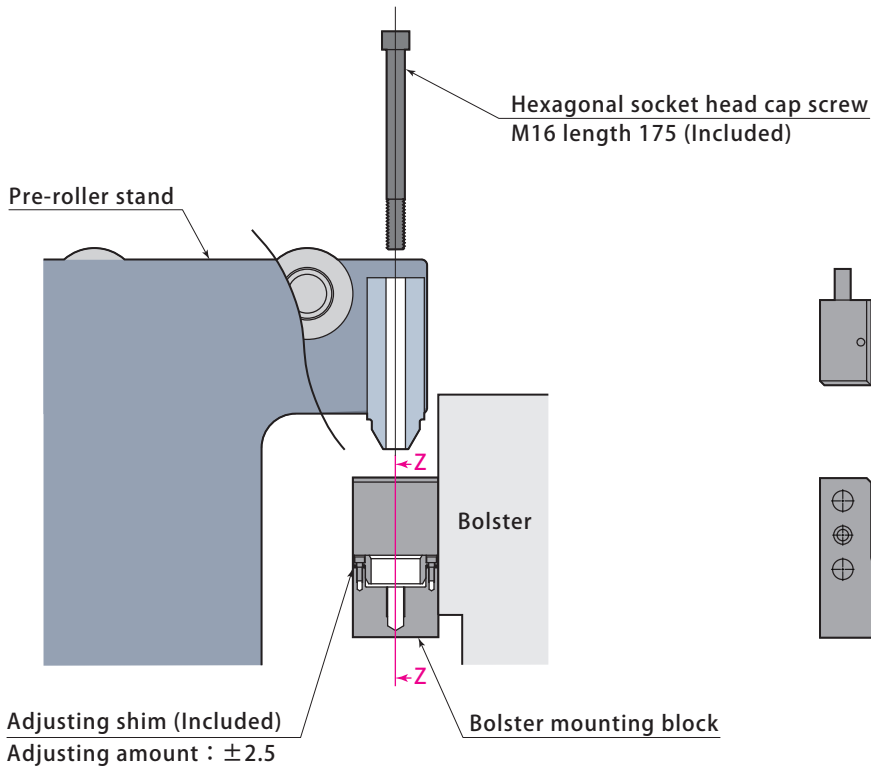

- The pre-roller stand can be shared by multiple machines.
Adjust the level by the adjuster.

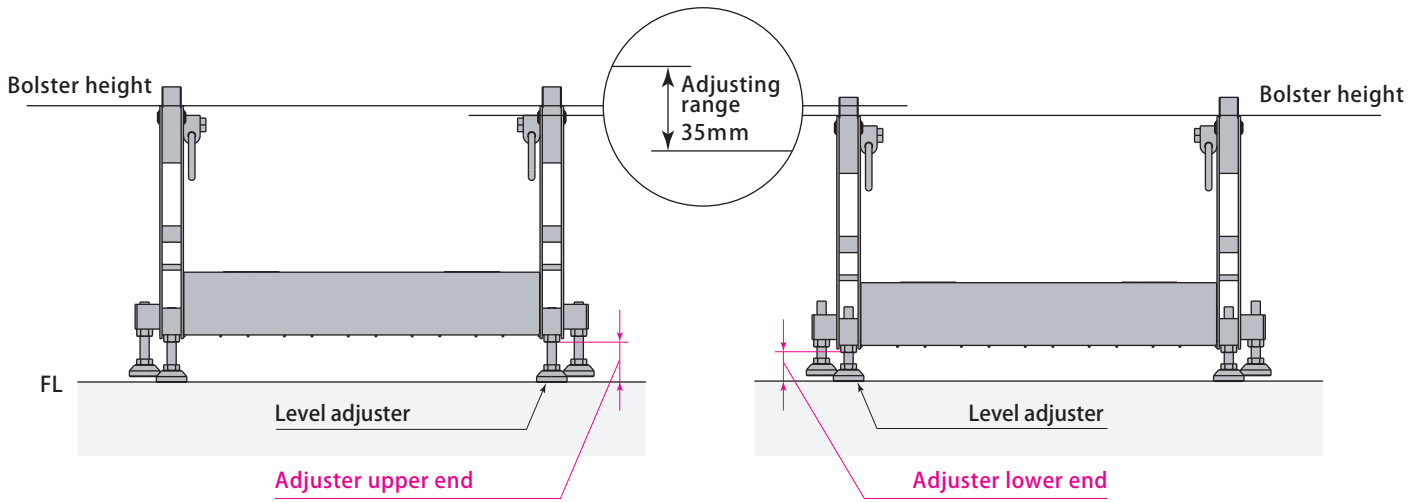

- The installation of the base (optional) enables the level adjustment work eliminate.

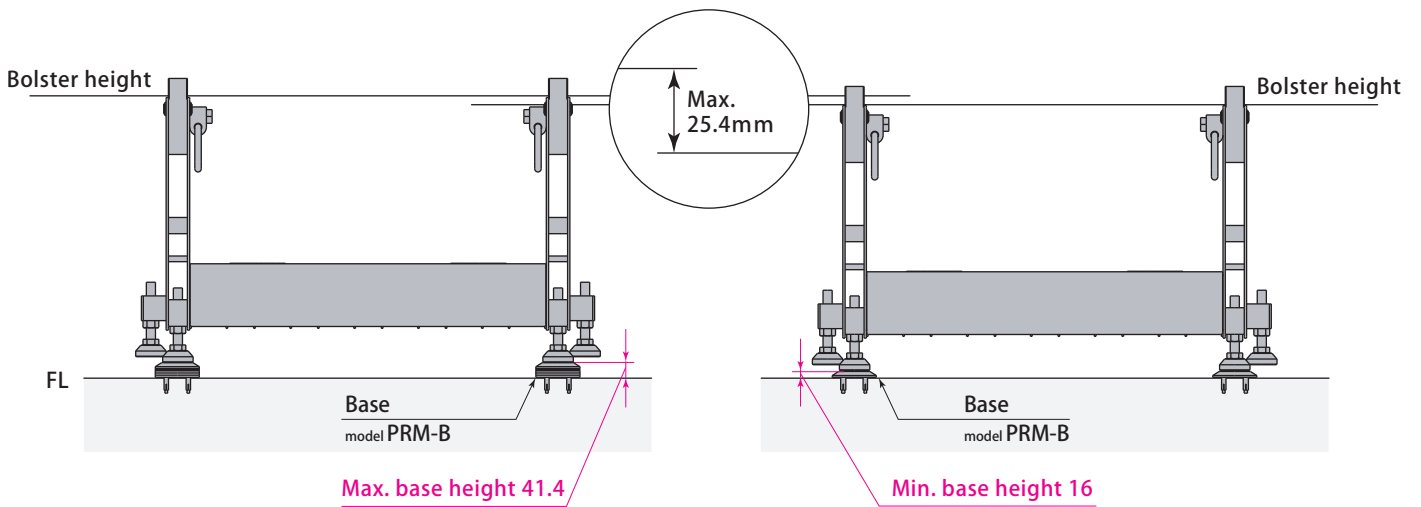

Base (Option)

Dimensions / Mounting Details

Base

PRM-B

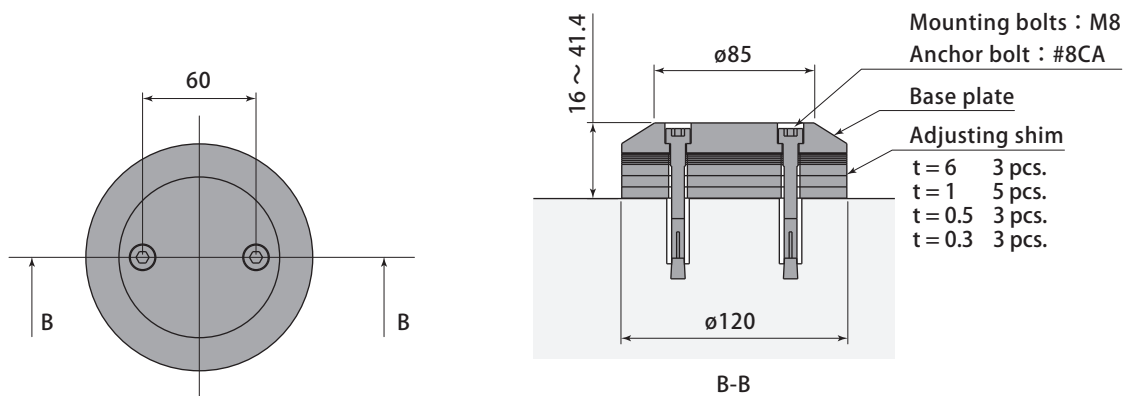

Model	PRM-B
Max.mass kg	3.4
Mounting bolts	M8 ※
Anchor bolt	#8CA

※The size varies depending on the base height.

Base height	Mounting bolts
16 ~ 20	2-M8 length 16
20.1 ~ 25	2-M8 length 20
25.1 ~ 30	2-M8 length 25
30.1 ~ 35	2-M8 length 30
35.1 ~ 40	2-M8 length 35
40.1 ~ 41.4	2-M8 length 40

Pascal control system

Pascal control system



Control system
Example of hydraulic circuit

Pascal pump

model

X63



Control system
Example of hydraulic circuit

New series of Pascal pump model X63 which pursues more reliability.

Air-driven, Compact, High performance hydraulic pump

High cycle, reliable reciprocation of air and hydraulic piston ensures a repetitive suction and discharge oil process. As discharge pressure hikes up to the circuit set pressure, reciprocation goes slow eventually. Pascal pump stops at the time the discharge pressure reaches the set pressure then keeps balancing air and oil discharge pressure.

At the balanced condition, Pascal pump never consumes air and there is no power loss or oil temperature rise unlike an ordinary electric motor pump.

In the event of pressure drop (oil leakage) in the circuit, the pump immediately reacts to start pumping for recovering the pressure loss. When leaking oil, the pump restarts pumping and the sound of pumping is like an alarm for leakage to call operator for servicing.

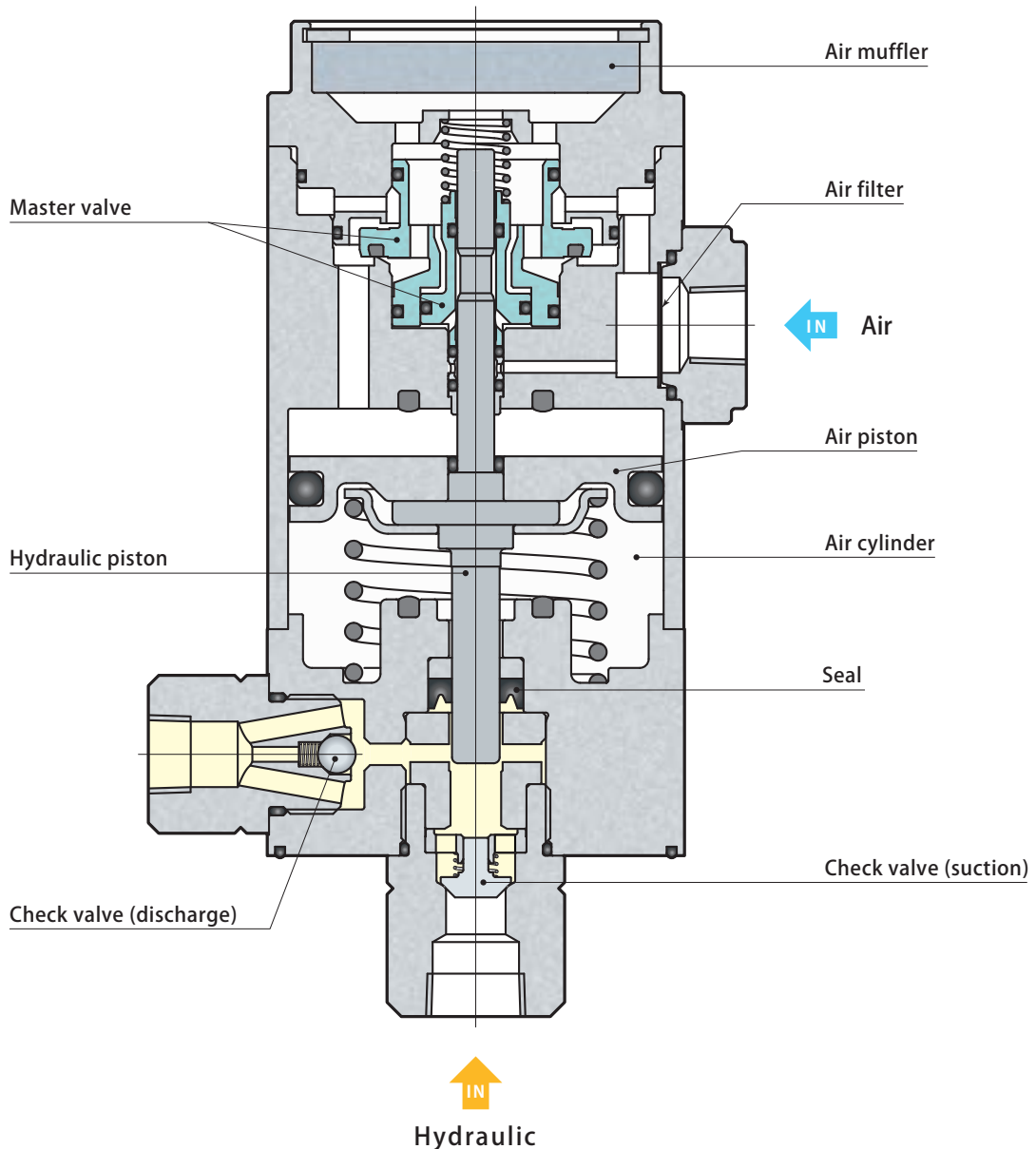

Pascal control unit

model

HCS

Control system
Example of hydraulic circuit

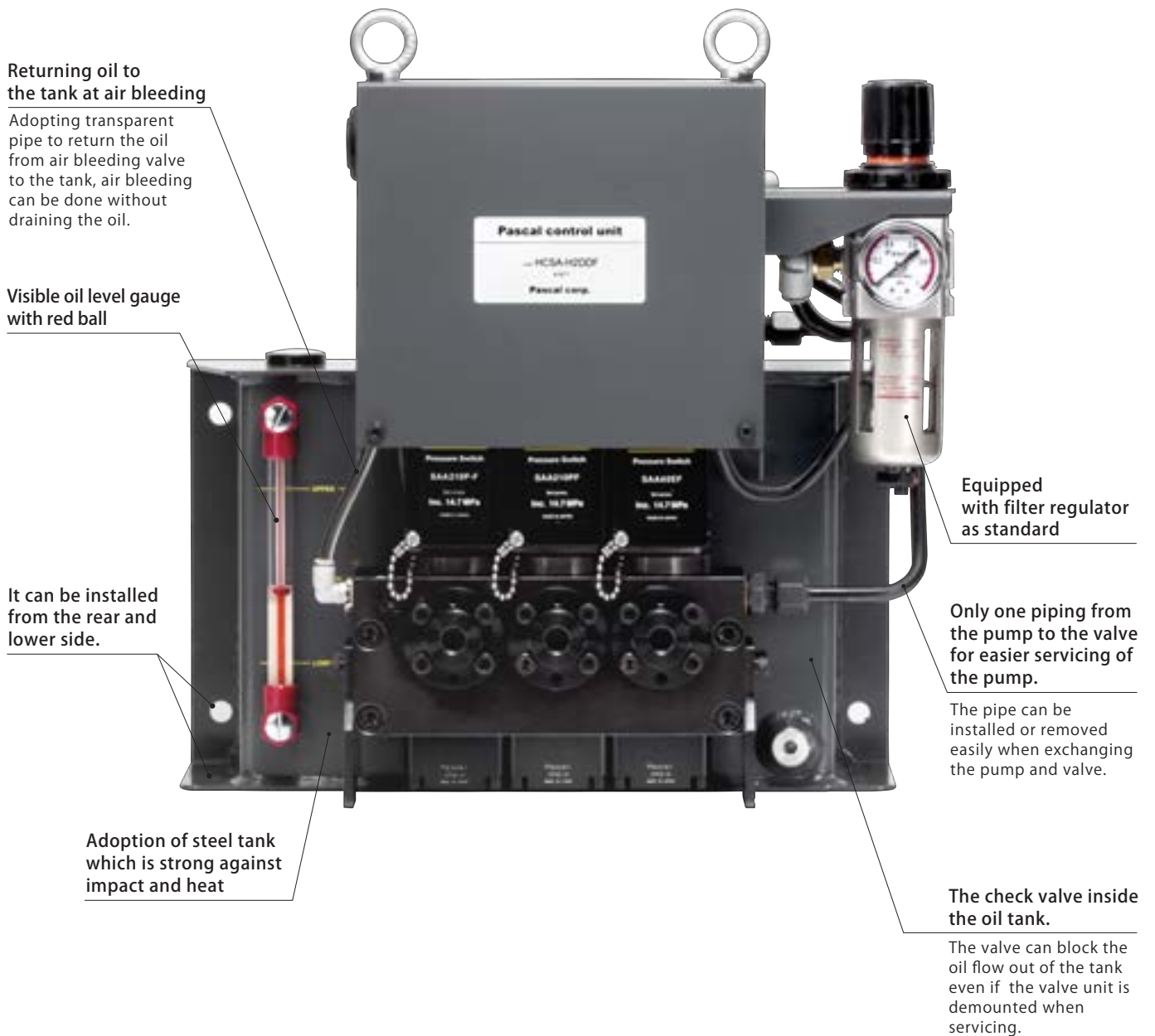

**New Control Unit model HCS
which enables a quick maintenance.**

An electric control type of hydraulic unit suitable for small and medium press machine, consisting of Pascal pump, non leak valve unit and air solenoid valve.

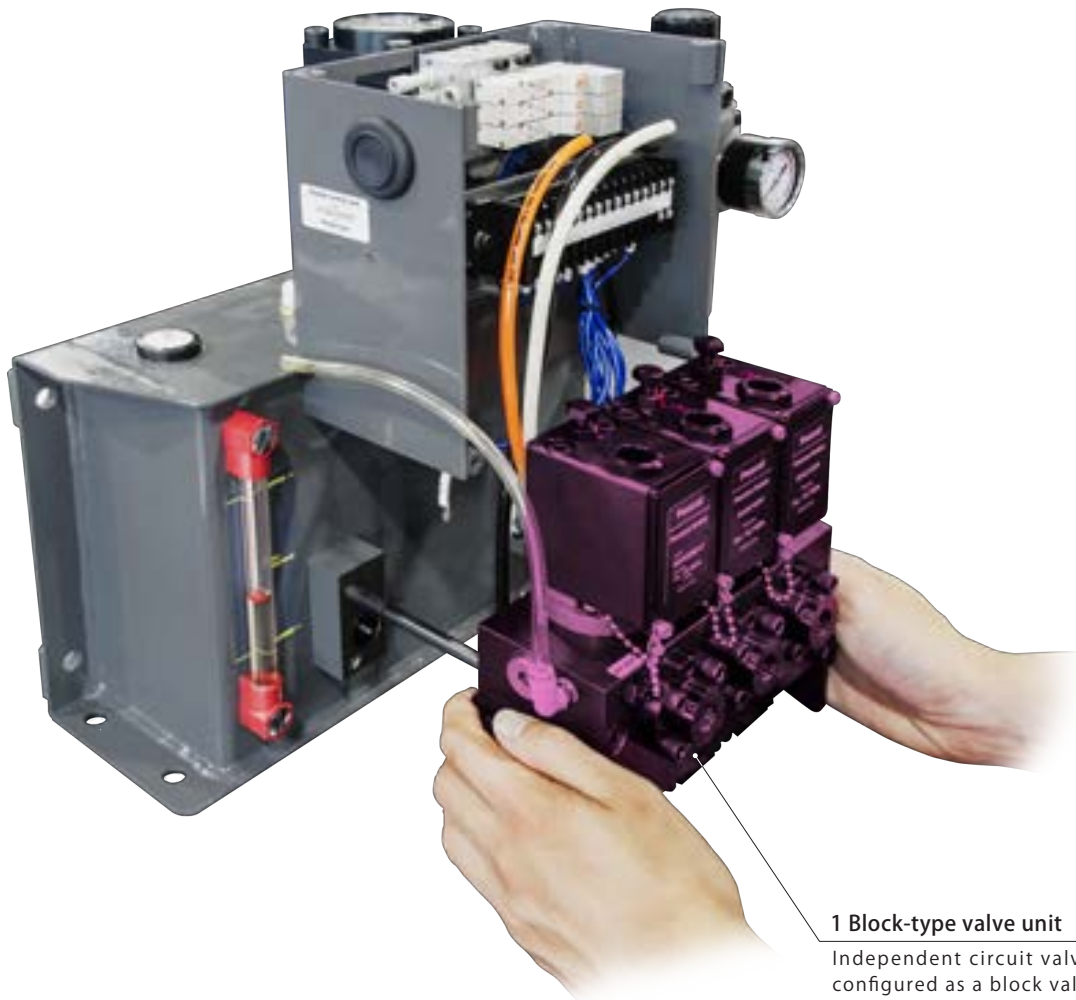

1 Block-type valve unit

Independent circuit valves have been configured as a block valve, improving maintainability.



Model designation

HCS **A** - H2 **D D F** - **U**

- 1 Control voltage
- 2 Hydraulic circuits
* Indicated in 1-4 alphabets
- 3 Oil pressure gauge for each circuit

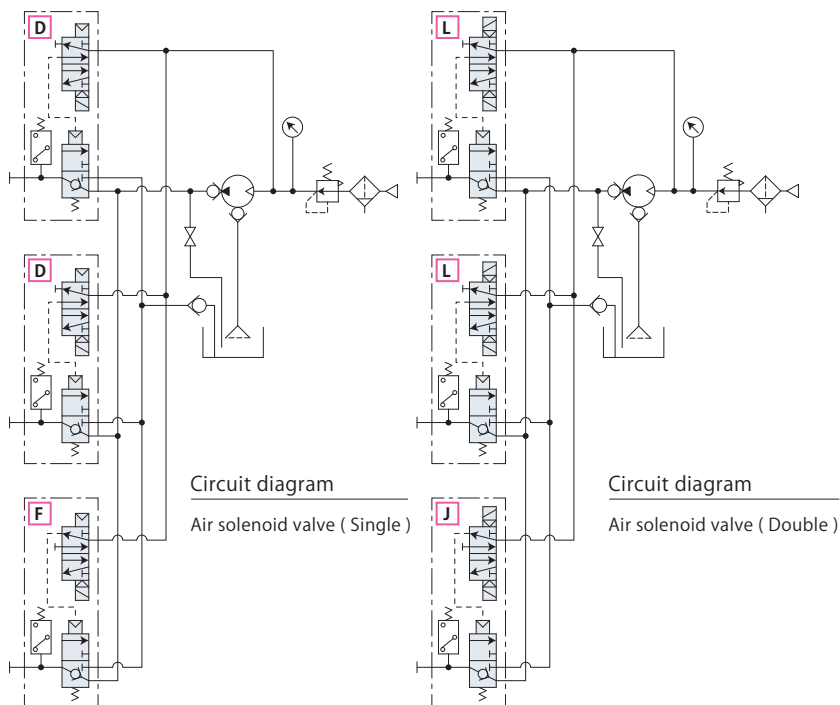

1 Control voltage

A	B	C	D	E
AC100V	AC200V	AC110V	DC24V	AC220V

2 Hydraulic circuits

Number of hydraulic circuits			Hydraulic circuits	
Upper clamp	Lower clamp	Die-lifter	Air solenoid valve (Single)	Air solenoid valve (Double)
	1	—	D	L
1	1	—	DD	LL
2	1	—	DDD	LLL
2	2	—	DDDD	LLLL
1	1	1	DDF	LLJ
2	1	1	DDDF	LLLJ

Clamp circuit Air solenoid valve (Single) : D Air solenoid valve (Double) : L
Die-lifter circuit Air solenoid valve (Single) : F Air solenoid valve (Double) : J

3 Oil pressure gauge for each circuit

- / : Without
- U : With

Specifications

Model	HCS□-H2□-□		
Number of pumps	1		
Valve switching system	Air pilot system		
Discharge pressure	MPa	24.5	
Driving air pressure	MPa	0.47	
Discharge volume (at no load)	L/min	1.3	
Oil tank capacity	L	HIGH-LEVEL : 3.5	LOW-LEVEL : 1.5
Set pressure of pressure switch	MPa	Clamp circuit : 14.7 (INC.)	Die-lifter circuit : 1.96 (DEC.)
Orifice diameter	mm ²	Discharge : 12.5	Return : 28.1
Air consumption rate	Nm ³ /min	Max. 0.4	

- Fluid used : General mineral based hydraulic oil (ISO-VG32 equivalent)
- Operating temperature : 0 ~ 50°C (No frozen)

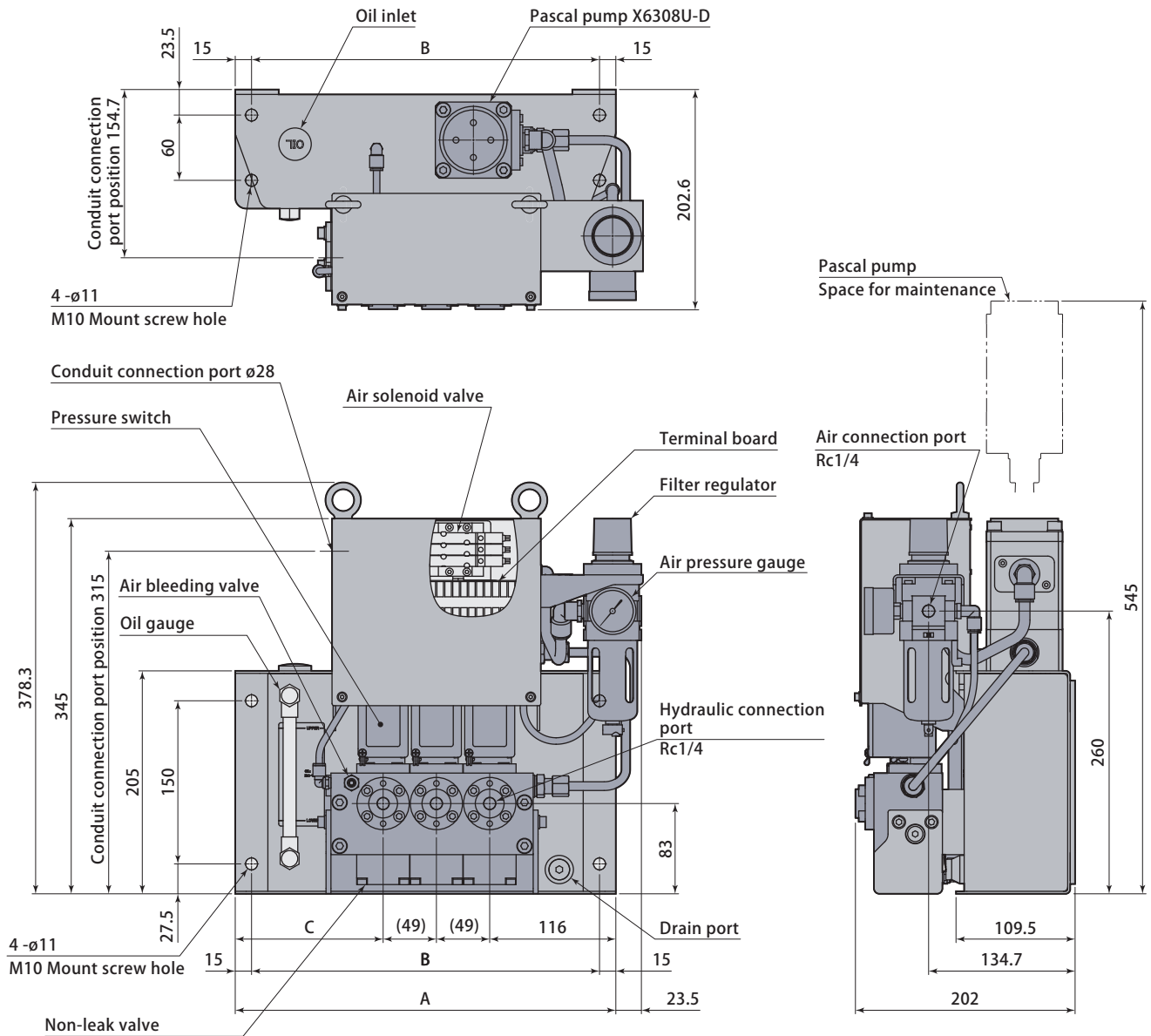

Number of hydraulic circuits		1	2	3	4
A	mm	350	350	350	400
B	mm	320	320	320	370
C	mm	234	185	136	137
Weight	kg	17	20	22	25

Orifice diameter (Option 4 pieces)

model ZPS-B5

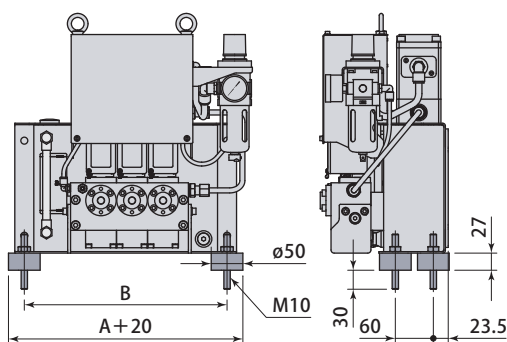

Stand (Option)

model ZPS-S0

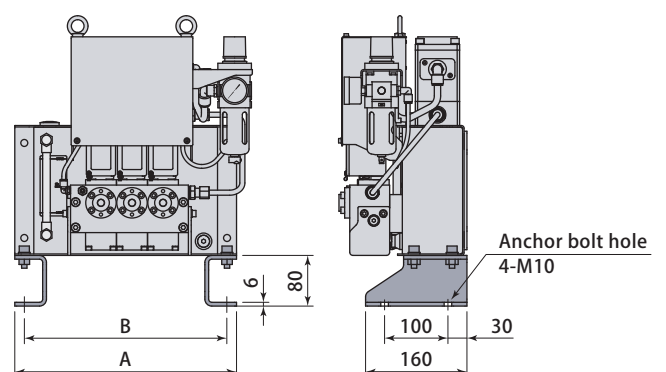



Model designation

HCP **A** - **H2** **D** **D** **F** - **U**

- 1 Control voltage
- 2 Pump quantity
- 3 Hydraulic circuits
* Indicated in 1-4 alphabets
- 4 Special specifications

1 Control voltage

A	B	C	D	E
AC100V	AC200V	AC110V	DC24V	AC220V

2 Pump quantity **H2** : 1unit **H22** : 2units

3 Hydraulic circuits

Number of hydraulic circuits			Hydraulic circuits	
Upper clamp	Lower clamp	Die-lifter	Air solenoid valve (Single)	Air solenoid valve (Double)
	1	—	D	L
1	1	—	DD	LL
2	1	—	DDD	LLL
2	2	—	DDDD	LLLL
1	1	1	DDF	LLJ
2	1	1	DDDF	LLLJ

Clamp circuit Air solenoid valve (Single) : D Air solenoid valve (Double) : L
Die-lifter circuit Air solenoid valve (Single) : F Air solenoid valve (Double) : J

Specifications

Model	HCP□-H2□-□		HCP□-H22□-□	
	1		2	
Number of pumps	1		2	
Valve switching system	Air pilot system			
Discharge pressure	MPa	24.5		
Driving air pressure	MPa	0.47		
Maximum working pressure	MPa	30.8		
Discharge volume (at no load)	L/min	1.3	2.6	
Oil tank capacity	L	HIGH-LEVEL : 5.4	/	LOW-LEVEL : 2.2
Set pressure of pressure switch	MPa	Clamp circuit : 14.7 (INC.)	/	Die-lifter circuit : 1.96 (DEC.)
Orifice diameter	mm ²	Discharge : 12.5	/	Return : 28.1
Air consumption rate	Nm ³ /min	Max. 0.4	Max. 0.8	

- Fluid used : General mineral based hydraulic oil (ISO-VG32 equivalent)
- Operating temperature : 0 ~ 50°C (No frozen)
- Standard working pressure : 24.5MPa
- For 5 or more circuits application, contact Pascal for the details.

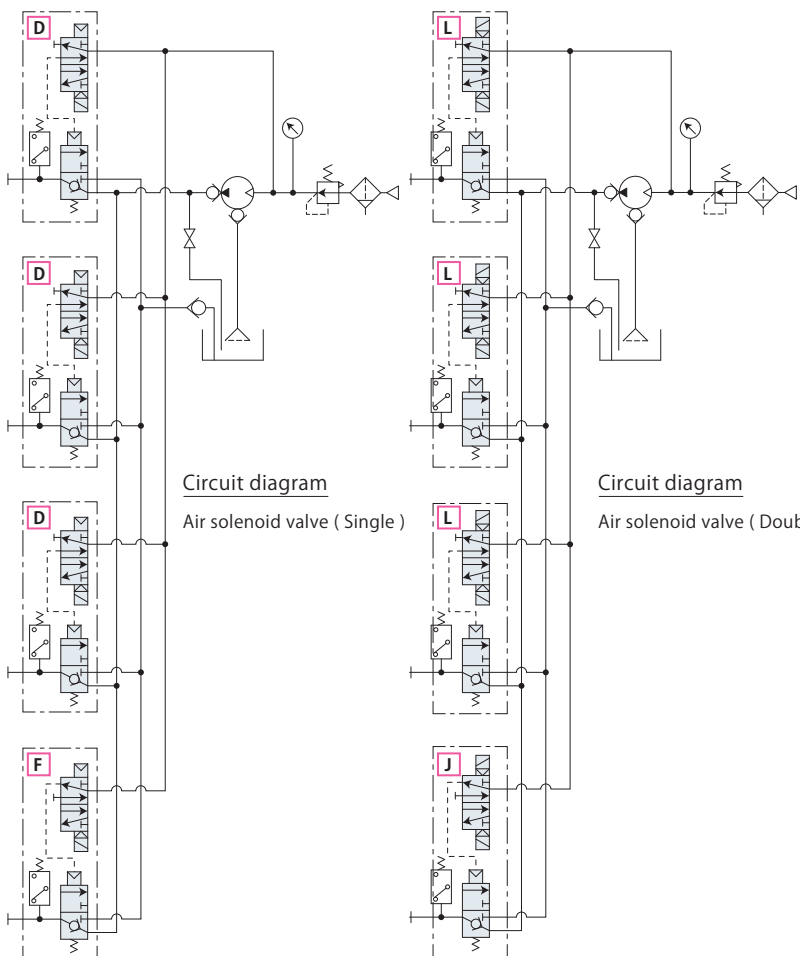

4 Special specifications

- : Without
- L : Low oil level detection switch
- T2 : For auto slider 2-position double air solenoid valve equipped
- T3 : For auto slider 3-position center exhaust air solenoid valve equipped
- U : Oil pressure gauge for each circuit

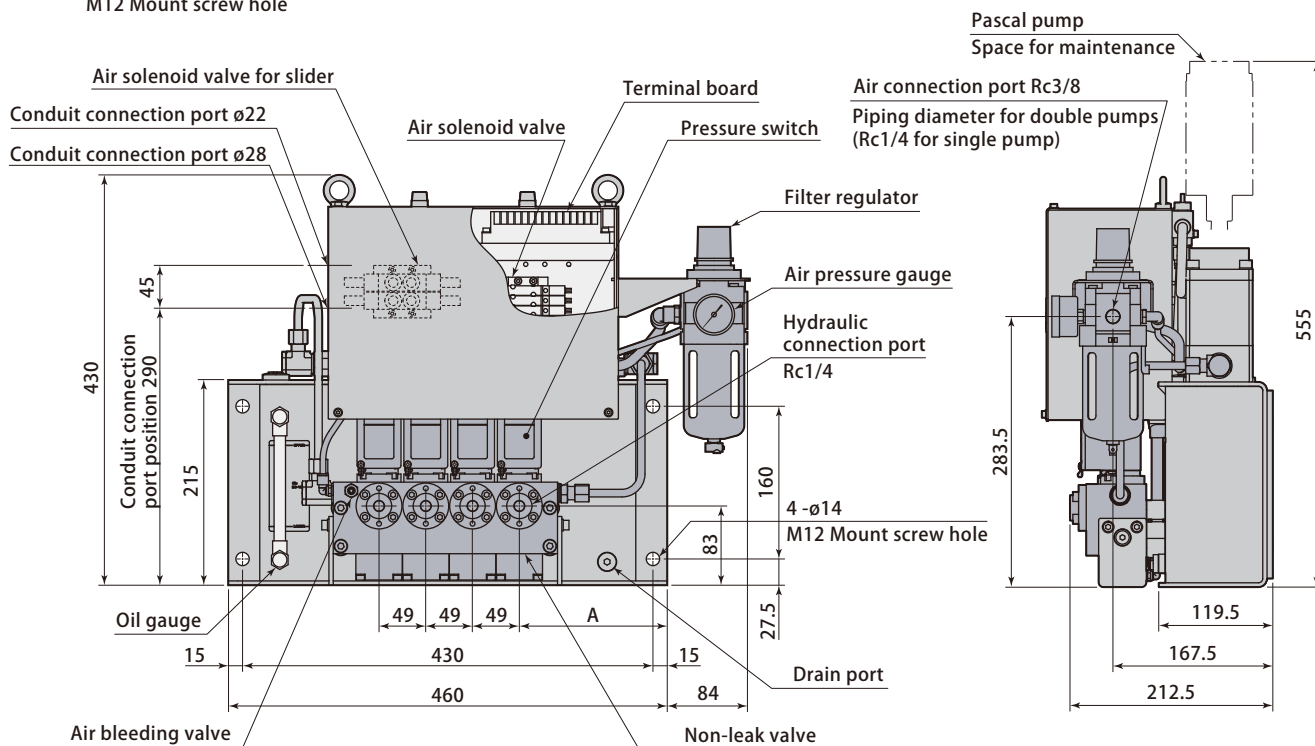
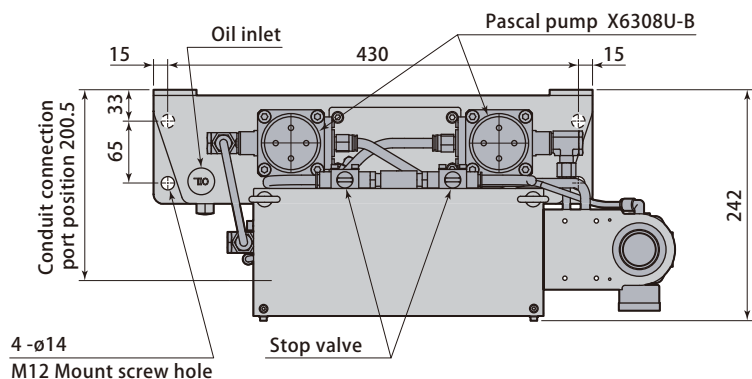

Number of hydraulic circuits	1	2	3	4	
A	mm	204	179.5	155	155
Weight	kg	28	30	32	35

● For the case of double pumps. 3kg to be decreased in case of single pump.

Orifice diameter (Option 4 pieces)

model ZPS-B6

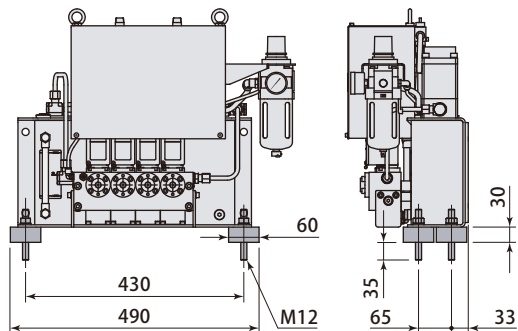

Stand (Option)

model ZPS-S1

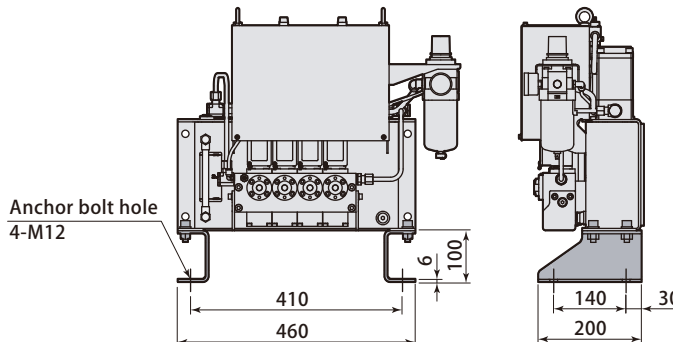



Model designation

VHA - A A C

1 Hydraulic circuits ●.....
* Indicated in 1-3 alphabets

1 Hydraulic circuits

Number of hydraulic circuits			Hydraulic circuits *	Weight kg
Upper clamp	Lower clamp	Die-lifter		
	1	—	A	4.2
—	—	1	B	4.2
1	1	—	AA	6.8
	1	1	C	6.8
2	1	—	AAA	9.0
1	1	1	AC	9.0
2	1	1	AAC	11.1

* C=A+B

Specifications

Model		VHA-□	
Standard working pressure	MPa	24.5	
Maximum working pressure	MPa	30.8	
Set pressure of pressure switch	Clamp circuit	MPa	14.7 (INC.)
	Die-lifter circuit	MPa	1.96 (DEC.)
Orifice diameter	mm ²	Discharge : 14.2 / Return : 14.2	

- Fluid used : General mineral based hydraulic oil (ISO-VG32 equivalent)
- Operating temperature : 0 ~ 70°C (No frozen)

VHA-A
VHA-B

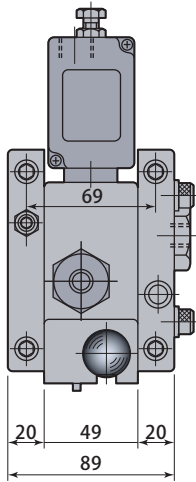

VHA-AA
VHA-C

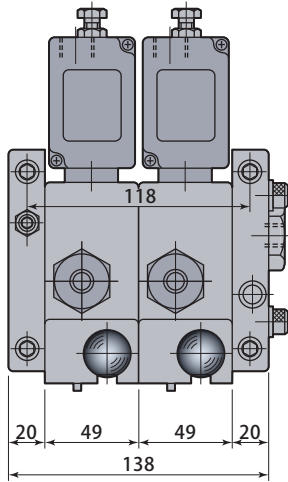

VHA-AAA
VHA-AC

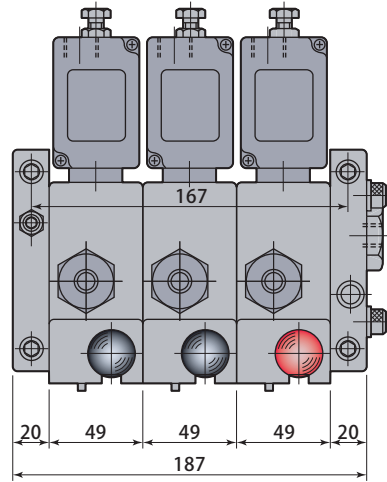

VHA-AAC

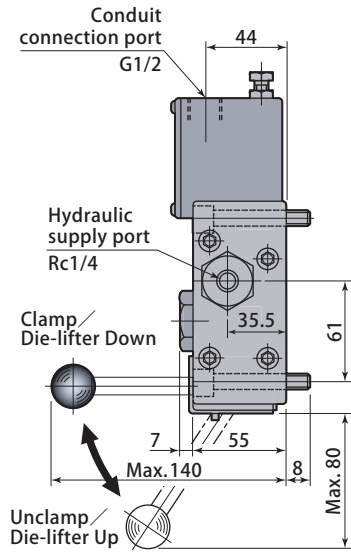
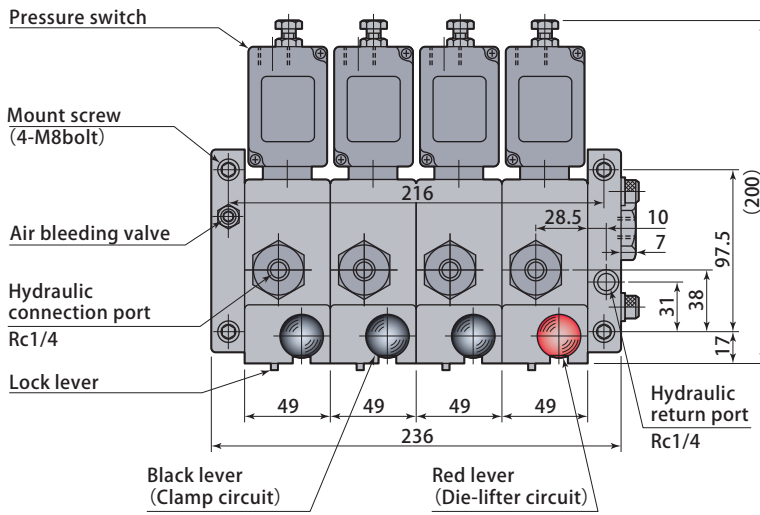

Orifice diameter (Option)
model ZPS-B3-HVSB1420

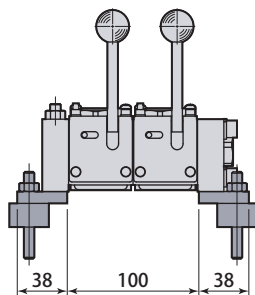
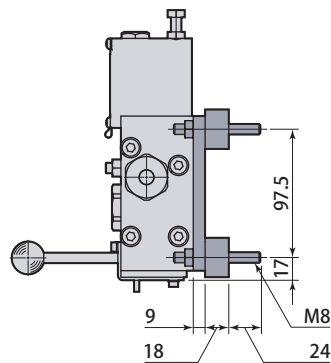
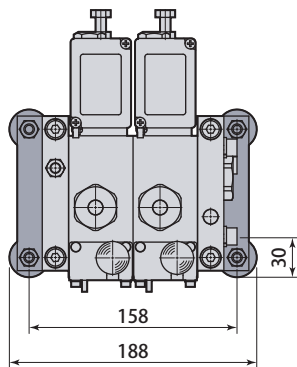



Model designation

HUT – 2

Specifications

Model		HUT-2
Number of pumps		1
Discharge pressure	MPa	24.5
Driving air pressure	MPa	0.47
Discharge volume (at no load)	L/min	1.3
Oil tank capacity	L	HIGH-LEVEL : 1.5 / LOW-LEVEL : 0.6
Air consumption rate	Nm ³ /min	Max. 0.4
Weight (without oil)	kg	8.3

- Fluid used : General mineral based hydraulic oil (ISO-VG32 equivalent)
- Operating temperature : 0 ~ 60°C (No frozen)

Circuit diagram

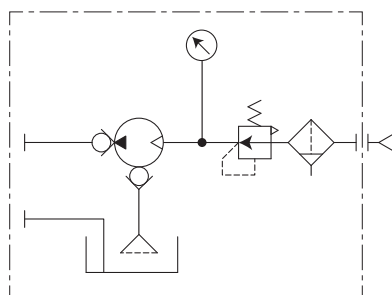

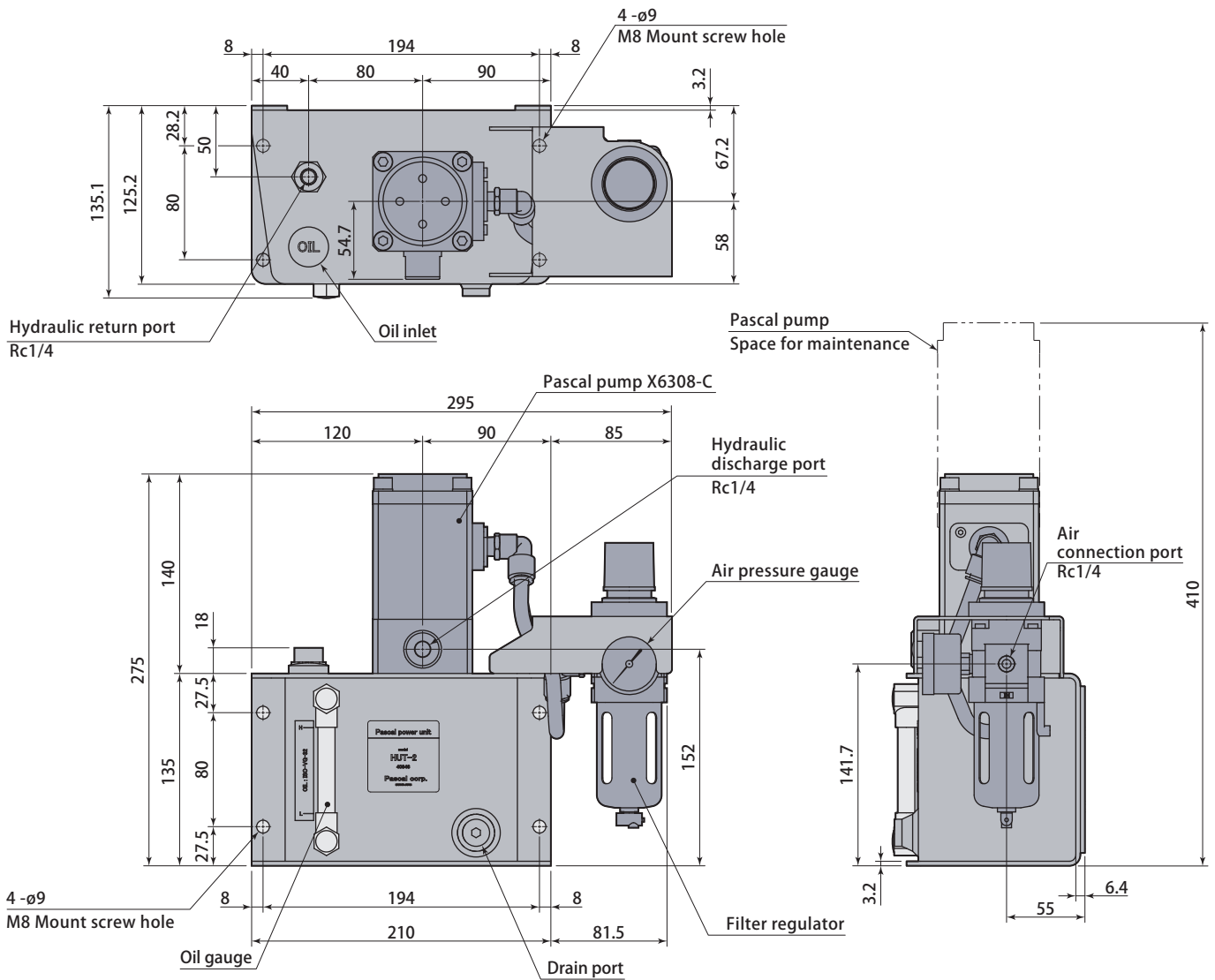

Orifice diameter (Option 4 pieces)
model ZPS-B3

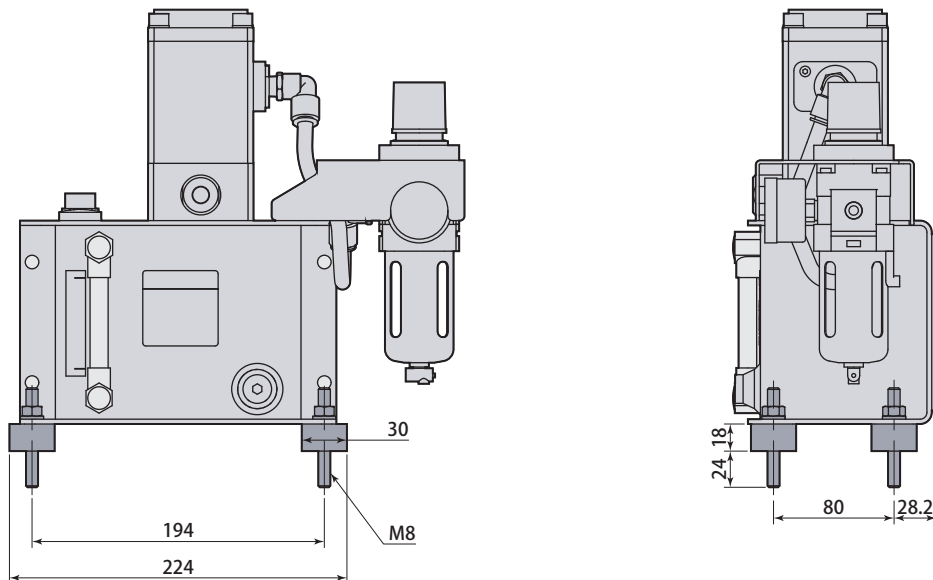



Model designation

VSB **A** - H2 **D D F**

- 1 Control voltage
- 2 Hydraulic circuits
* Indicated in 1-4 alphabets

1 Control voltage

A	B	C	D	E
AC100V	AC200V	AC110V	DC24V	AC220V

2 Hydraulic circuits

Number of hydraulic circuits			Hydraulic circuits	
Upper clamp	Lower clamp	Die-lifter	Air solenoid valve (Single)	Air solenoid valve (Double)
1		—	D	L
1	1	—	DD	LL
2	1	—	DDD	LLL
2	2	—	DDDD	LLLL
1	1	1	DDF	LLJ
2	1	1	DDDF	LLLJ

Clamp circuit Air solenoid valve (Single) : D Air solenoid valve (Double) : L
 Die-lifter circuit Air solenoid valve (Single) : F Air solenoid valve (Double) : J

Specifications

Model		VSB□-H2□
Standard working pressure	MPa	24.5
Maximum working pressure	MPa	30.8
Supply air pressure	MPa	0.4 ~ 0.7
Set pressure of pressure switch	Clamp circuit	14.7 (INC.)
	Die-lifter circuit	1.96 (DEC.)
Orifice diameter	mm ²	Discharge : 12.5 / Return : 28.1

- Fluid used : General mineral based hydraulic oil (ISO-VG32 equivalent)
- Operating temperature : 0 ~ 50°C (No frozen)

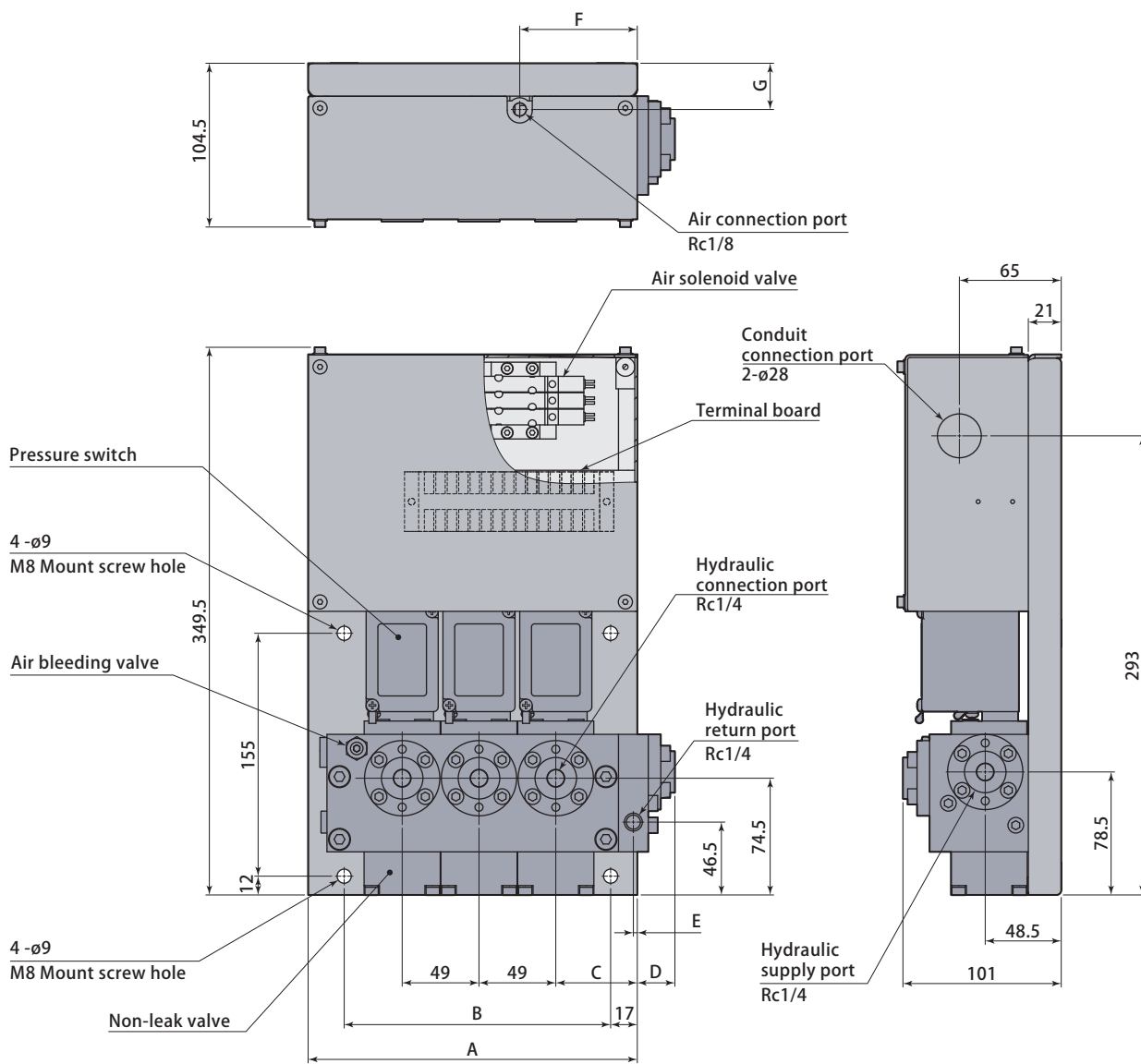

Non-leak valve unit VSB

Number of hydraulic circuits		1	2	3	4
A	mm	115	160	210	260
B	mm	80	120	170	220
C	mm	54	52	52	52
D	mm	22	24	24	24
E	mm	4.5	2.5	2.5	2.5
F	mm	57.5	55	75	75
G	mm	37.5	29.5	29.5	29.5
Weight	kg	8	10	13.5	16



Model designation

Circuit diagram

GSA 1 A

- 1 Number of circuits
- 2 Control voltage

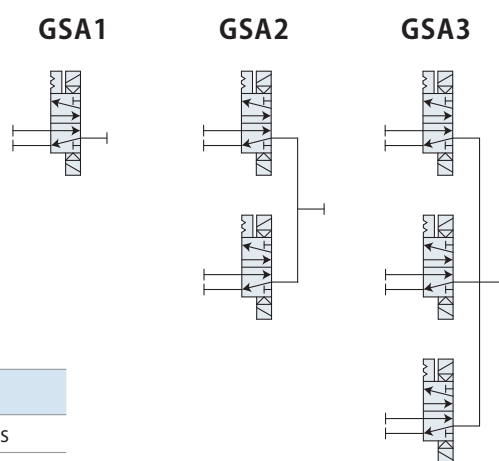

1 Number of circuits

1	2	3
1 circuit	2 circuits	3 circuits

2 Control voltage

A	B	C	D	E
AC100V	AC200V	AC110V	DC24V	AC220V

Specifications

Model		GSA1□	GSA2□	GSA3□
Number of circuits		1	2	3
Working air pressure	MPa	0.1 ~ 1		
Weight	kg	3.3	3.8	4.6

● Operating temperature : -10 ~ 60°C (No frozen)

GSA1

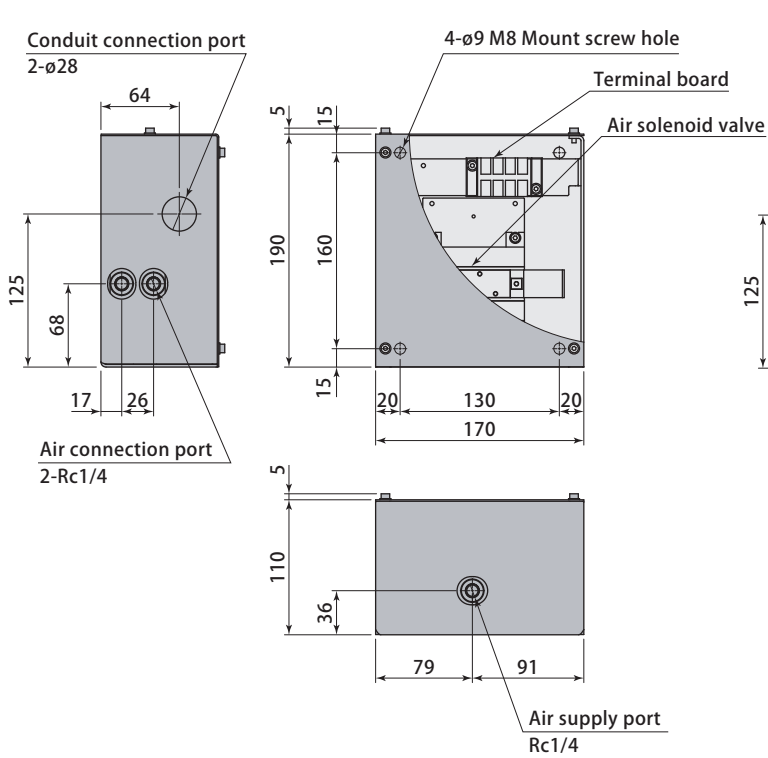

GSA2

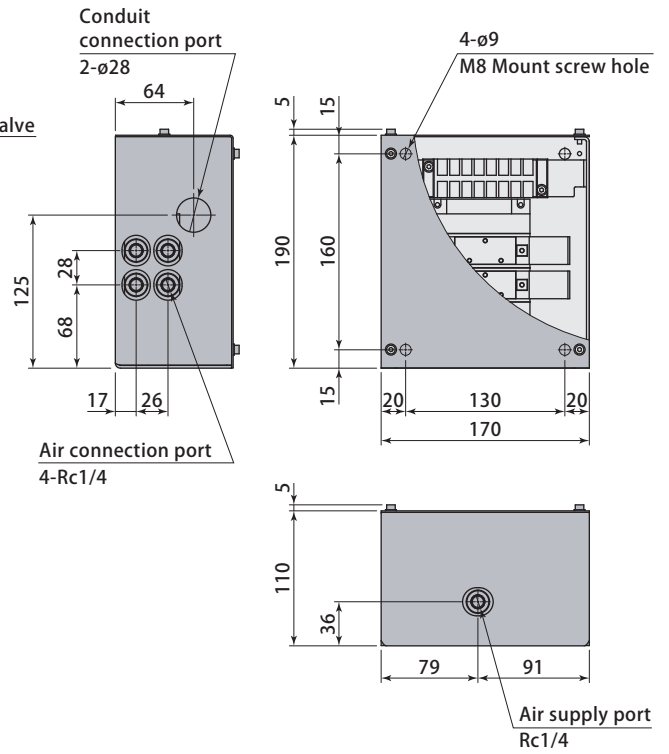

GSA3

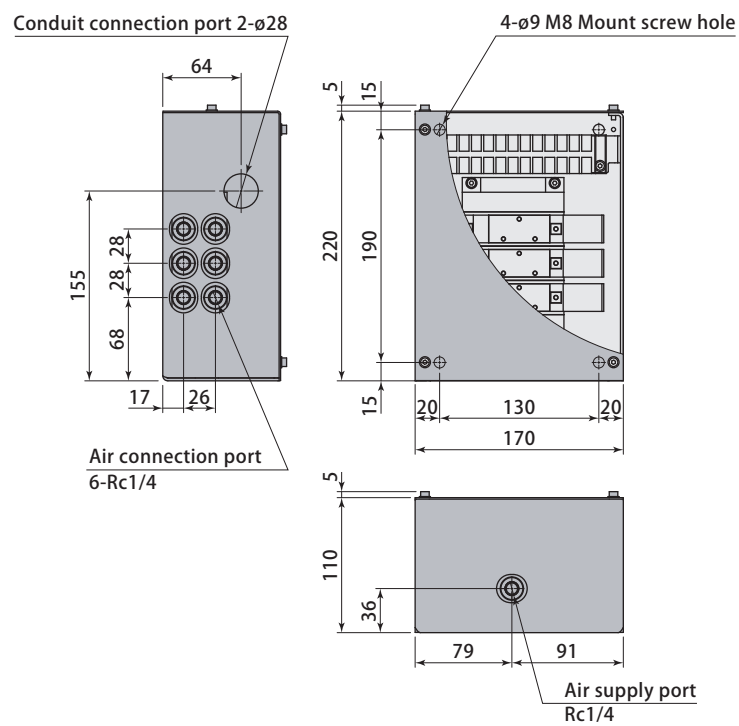

D Circuit

Number of hydraulic circuits		
Upper clamp	Lower clamp	Die-lifter
1		—

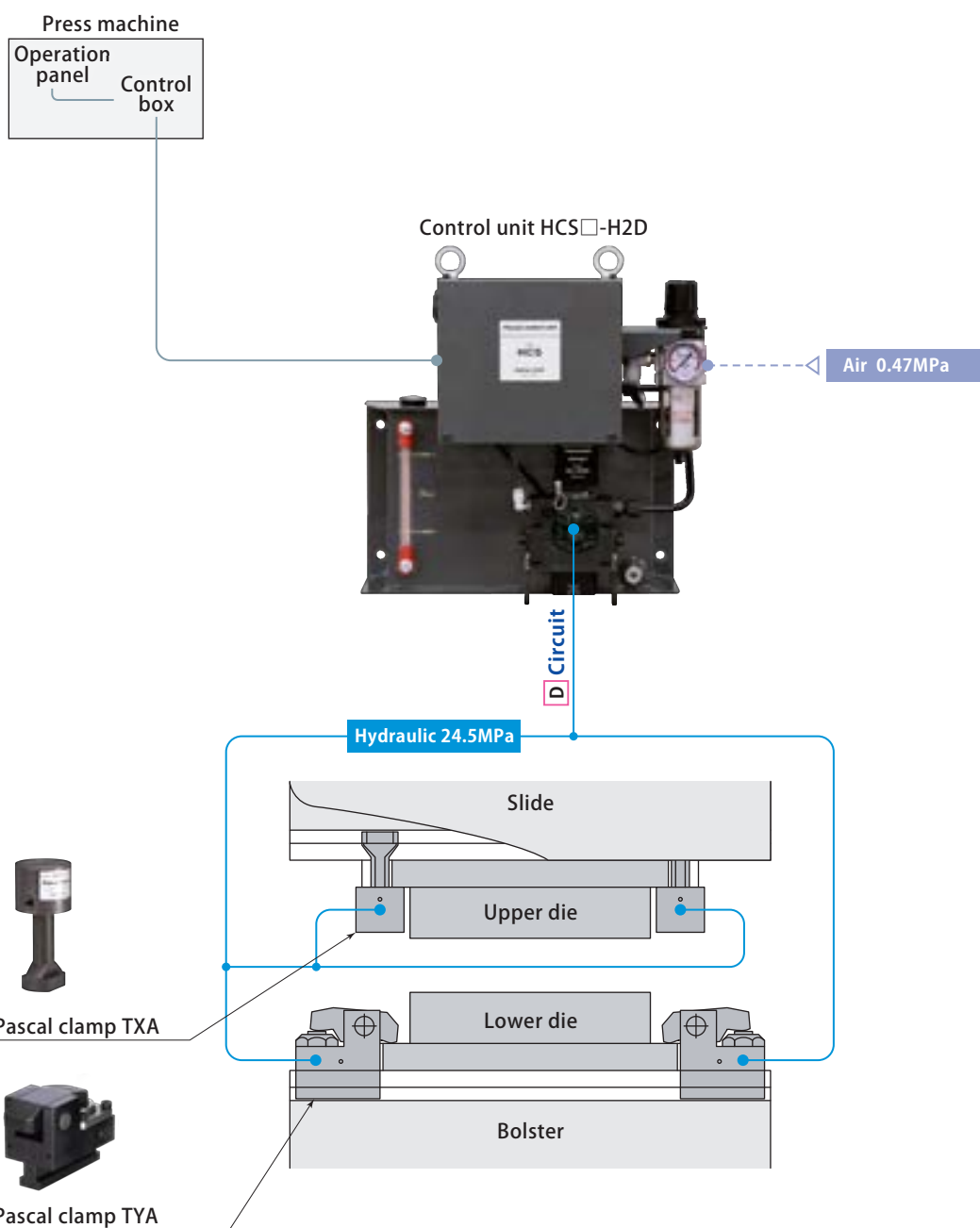

Control system
Example of hydraulic circuit

DD Circuits

Number of hydraulic circuits		
Upper clamp	Lower clamp	Die-lifter
1	1	—

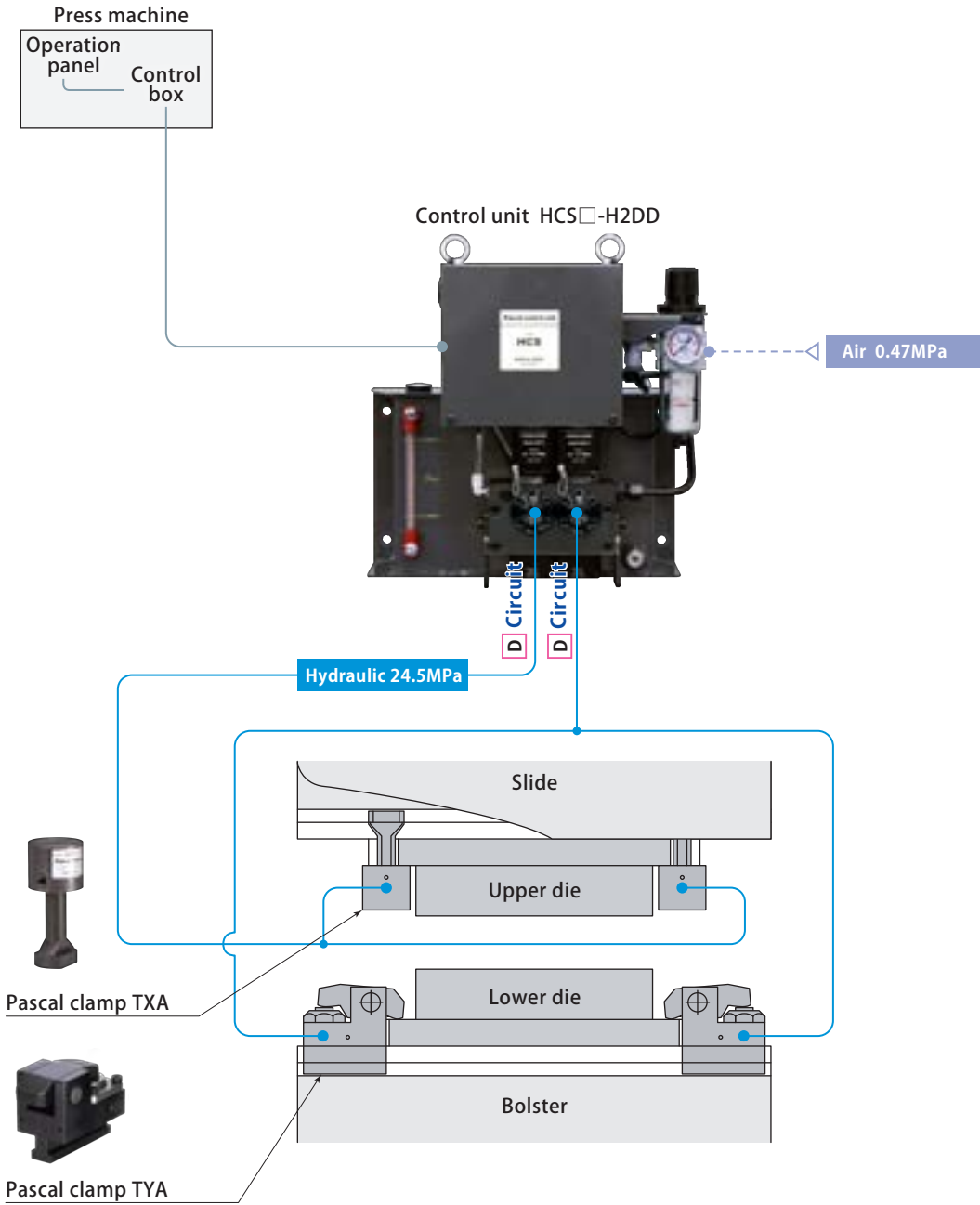

Control system
Example of hydraulic circuit

D D F Circuits

Number of hydraulic circuits		
Upper clamp	Lower clamp	Die-lifter
1	1	1

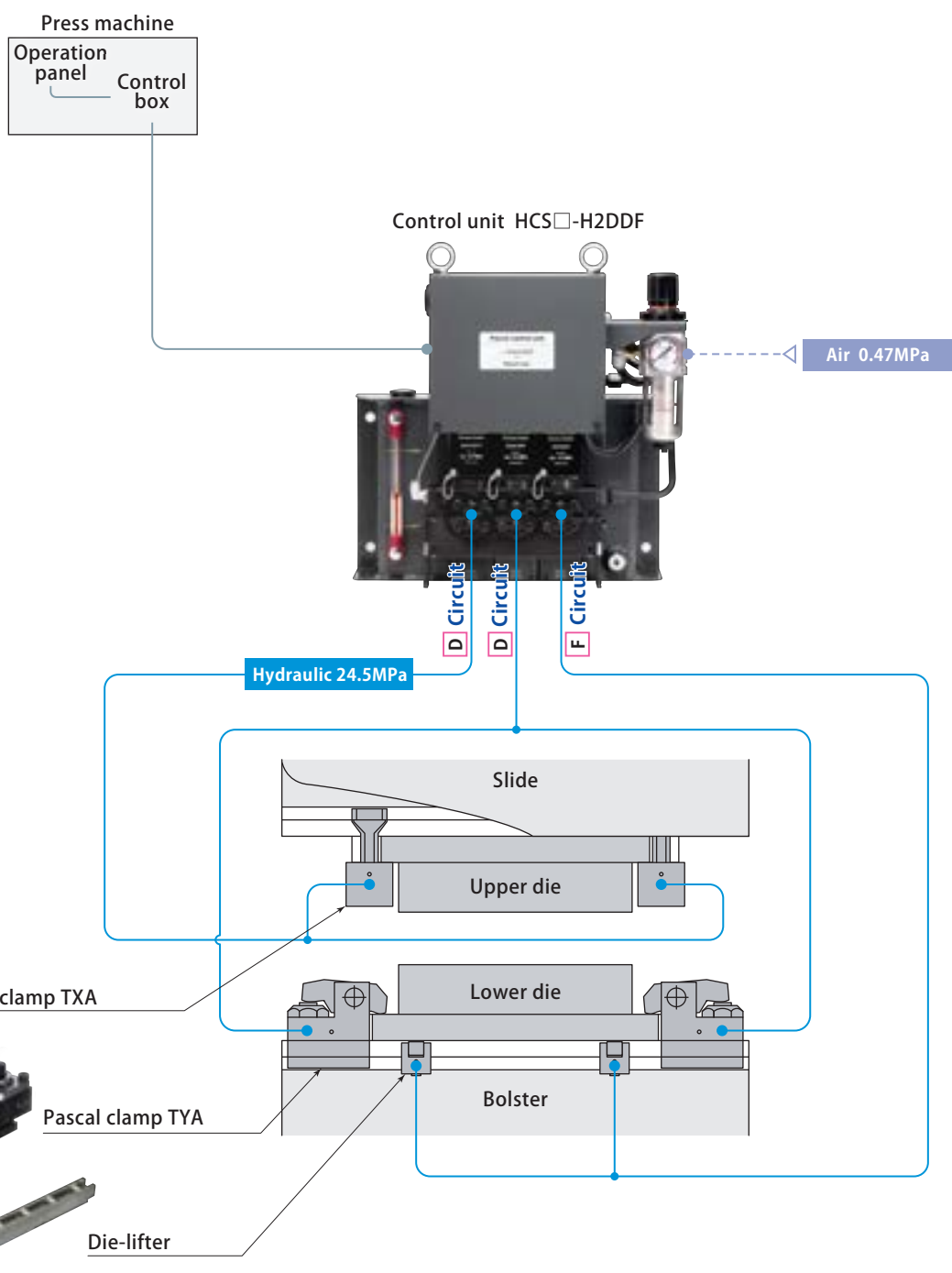

Control system
Example of hydraulic circuit

DDF Circuits

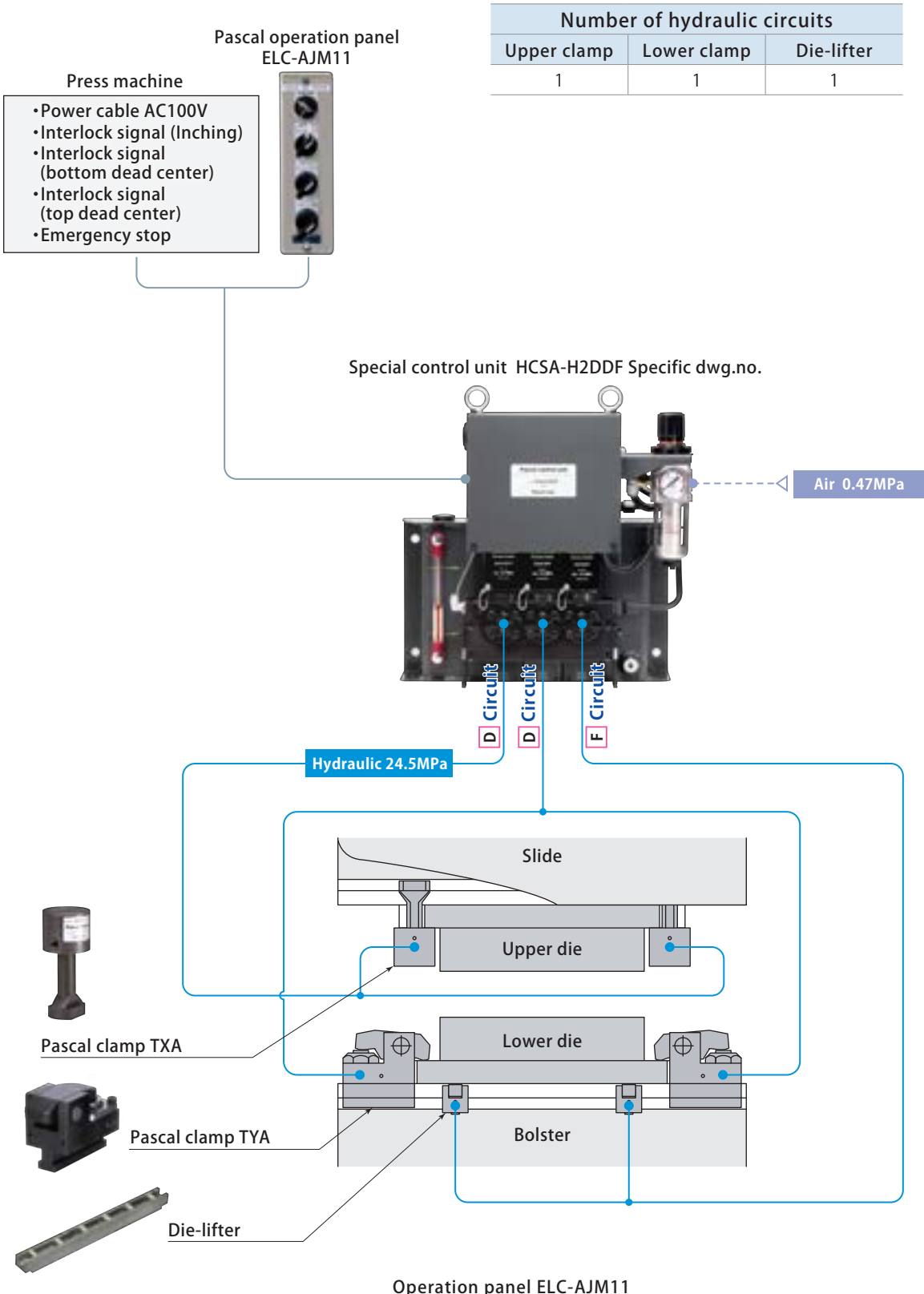

- It is a made-to-order product.
- It is designed for Japan domestic market. (Not complied with overseas standard)
- Model ELC-AJM10, which is applicable for DD circuit of control unit, is also available as an option.
- The control unit need a modification to combine to use with the operation panel. (The terminal block is added.)

A Circuit

Number of hydraulic circuits		
Upper clamp	Lower clamp	Die-lifter
	1	—

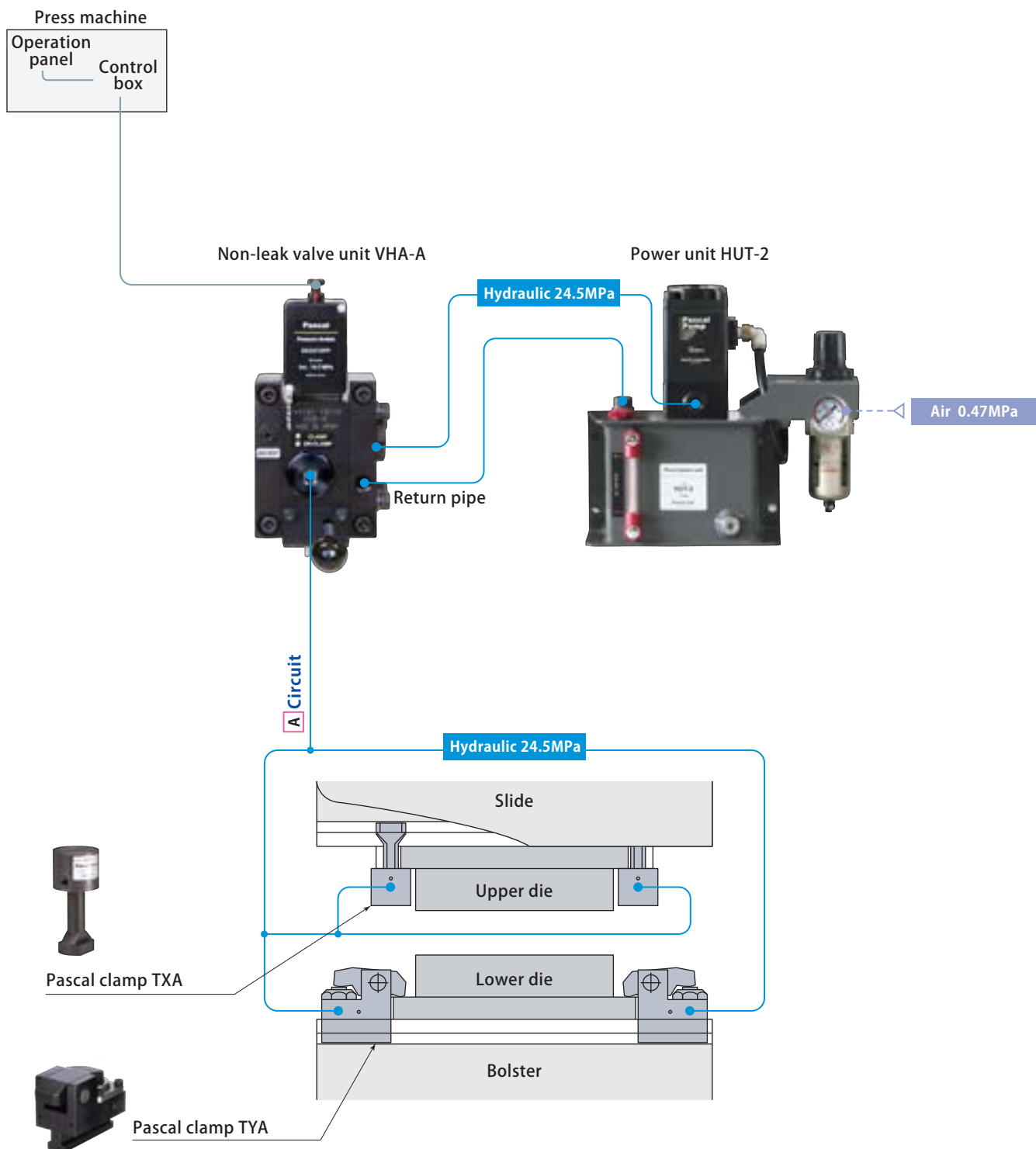

Control system
Example of hydraulic circuit

B Circuit

Number of hydraulic circuits		
Upper clamp	Lower clamp	Die-lifter
-	-	1

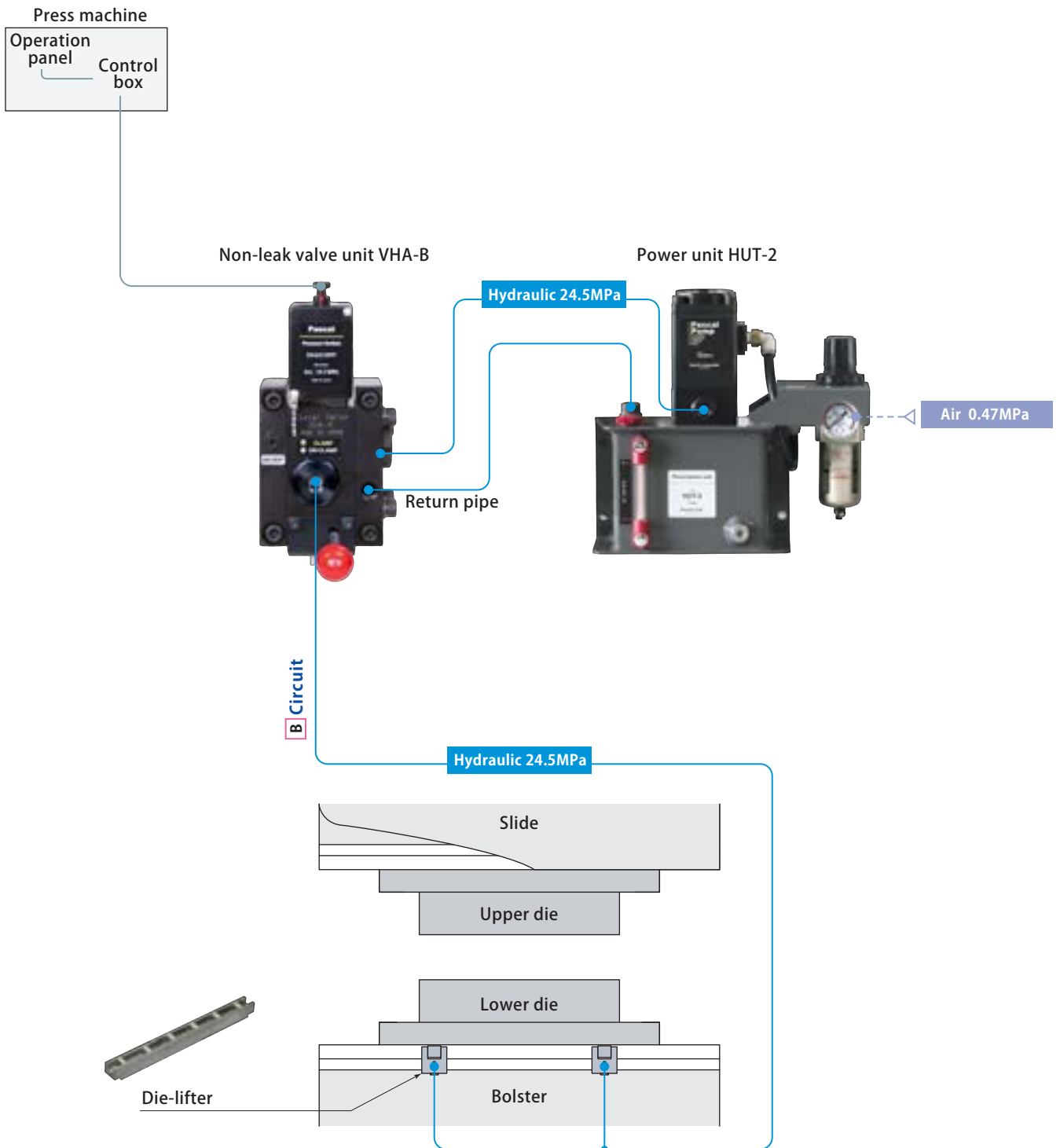

A C Circuits
 (**C = A + B Circuits**)

Number of hydraulic circuits		
Upper clamp	Lower clamp	Die-lifter
1	1	1

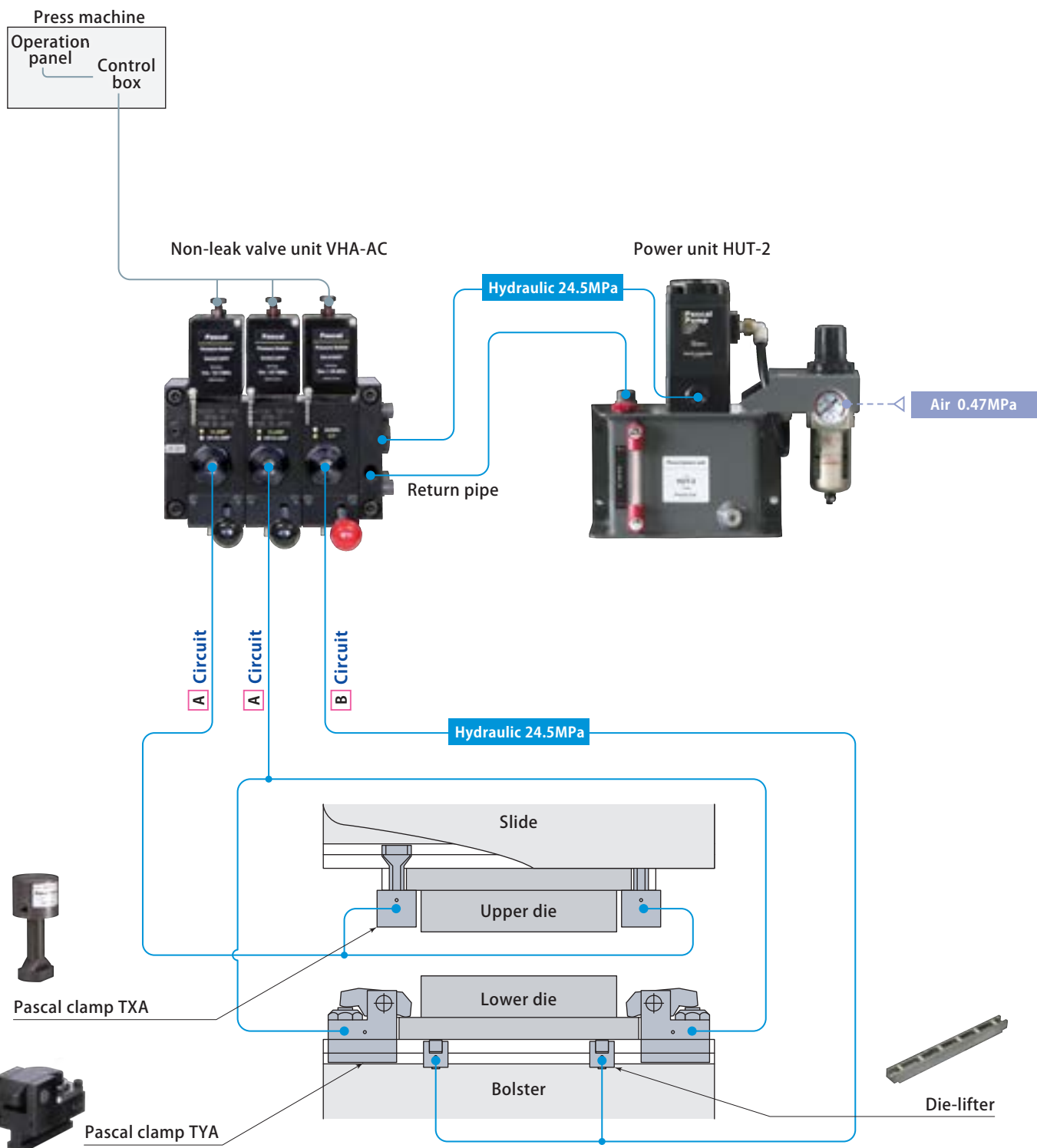

Control system
 Example of hydraulic circuit

DDF Circuits

Number of hydraulic circuits		
Upper clamp	Lower clamp	Die-lifter
1	1	—

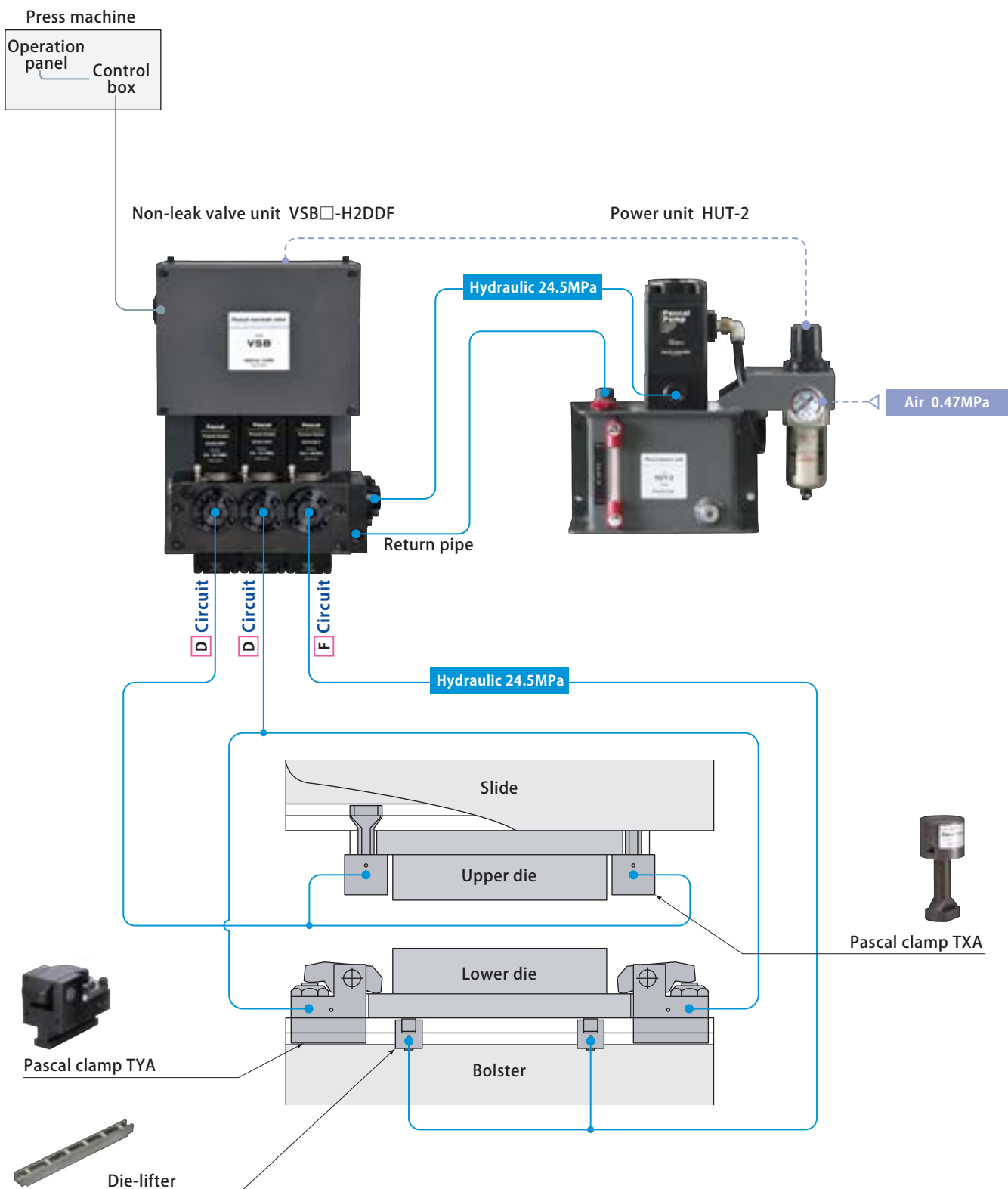

Control system
Example of hydraulic circuit

DD Circuits

Number of hydraulic and air circuits				
Upper clamp		Lower clamp		Die-lifter
Hydraulic pressure	Air	Hydraulic pressure	Air	Hydraulic pressure
1	1	1	1	—

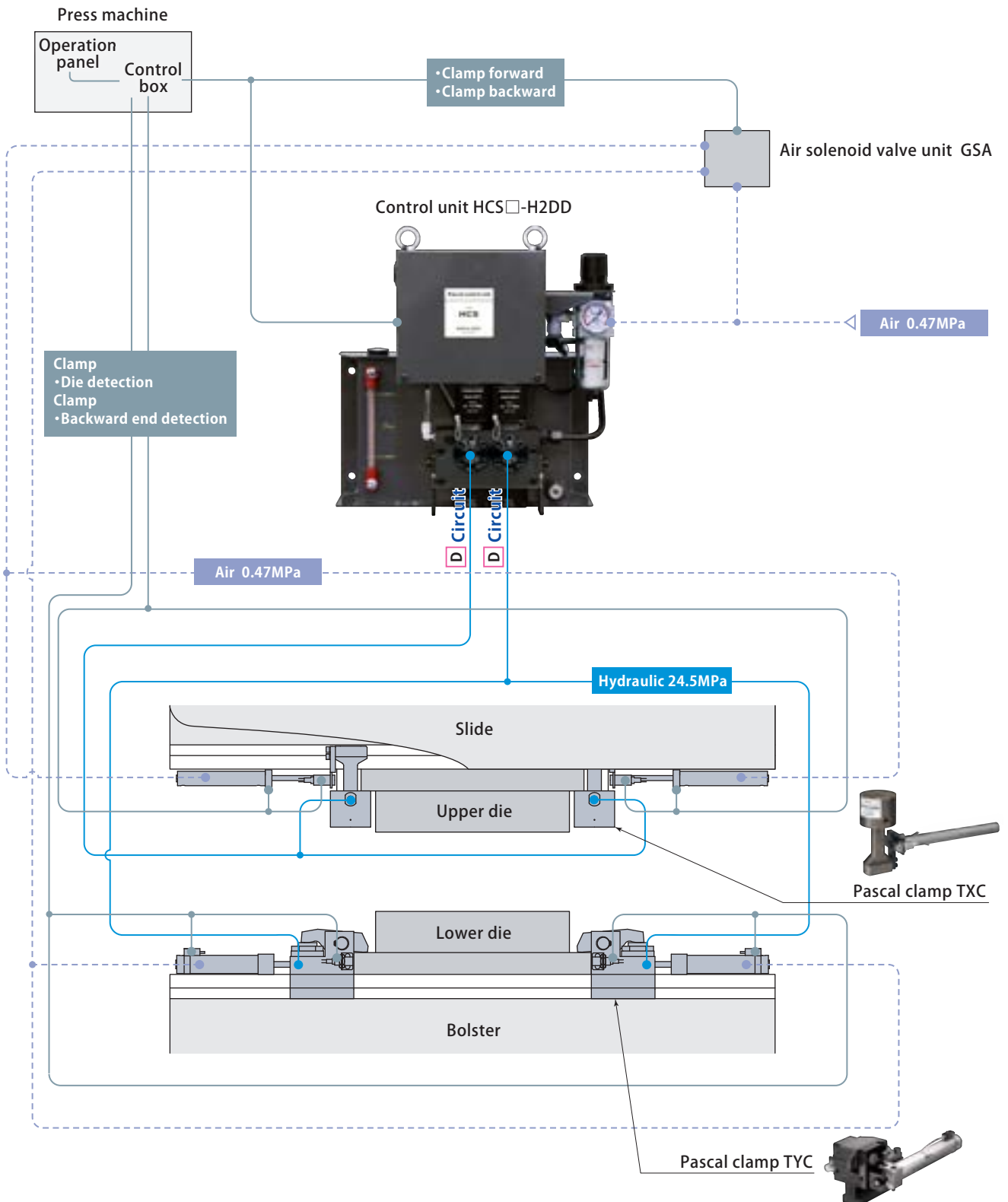

Control system
Example of hydraulic circuit

D D F Circuits

Number of hydraulic and air circuits				
Upper clamp		Lower clamp		Die-lifter
Hydraulic pressure	Air	Hydraulic pressure	Air	Hydraulic pressure
1	1	1	1	1

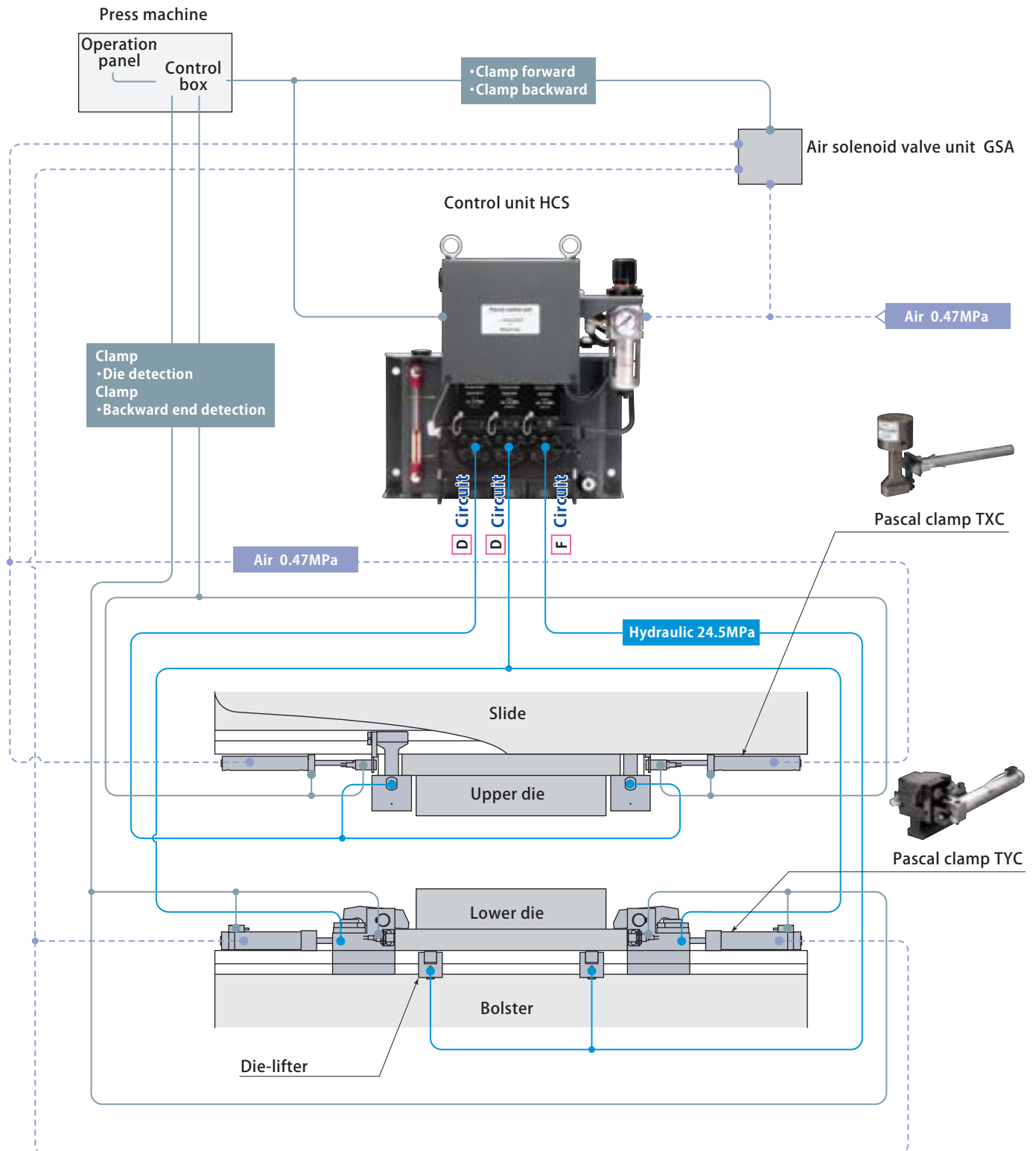

Control system
Example of hydraulic circuit

Traveling clamp

model **TRA**

Pascal traveling clamp series TR is an innovative stamping die clamping system, i.e, the clamp travels along T-slot and moves automatically to the die. By the introduction of TR series, the common plate is not required and it can reduce the die cost considerably. Compared with the conventional type of clamp which clamps edge of common plate, it can clamp strongly the die loading center and machines the press stably and with a high degree of accuracy. It has many delivery records for the automaker represented of Japan, and nowadays over 40,000 TR series are operating in the press line all over the world.

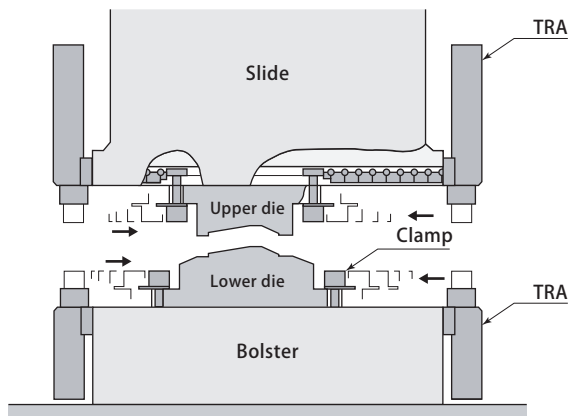

Control system

For middle or large press machine

It is powerful control unit for middle or large press machine.

* HUC and HUD are not mentioned in this catalogue. Contact Pascal for details.

Pascal control unit (Solenoid operated)



model **HCP**
(For medium and large press machine)

Pascal power unit

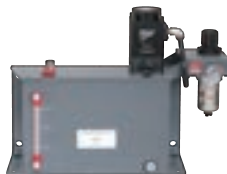

model **HUC**
(For medium and large press machine)

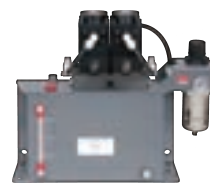

model **HUD**
(For medium and large press machine)

Swing clamp

model **THB**

It is most relevant clamp for introduction of the stamping die changer. It swings at right angle in the mounting position, so it does not interfere with the clamp at die loading.

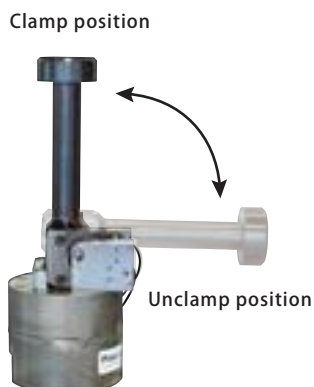

Die changer

model **MZ**

Pascal die changer is an automatic die changing system suitable for medium and large sized press, which can shorten the die change time a great deal, compared with the conventional type of die change such as forklift and overhead crane. For our example, 30-60 minutes (2-4persons) was required for die changing before, however only 3-5 minutes (1person) is required thanks to the die changer, so it can save time and energy and improves the productivity. In the press line, the high-mix low-volume/stockless/short delivery time production by minimum manpower can be realized and it has a significant effect in terms of the safety operation. Compared to the conventional moving bolster, Pascal die changer being specialized to exchange the die itself can reduce the equipment cost remarkably.

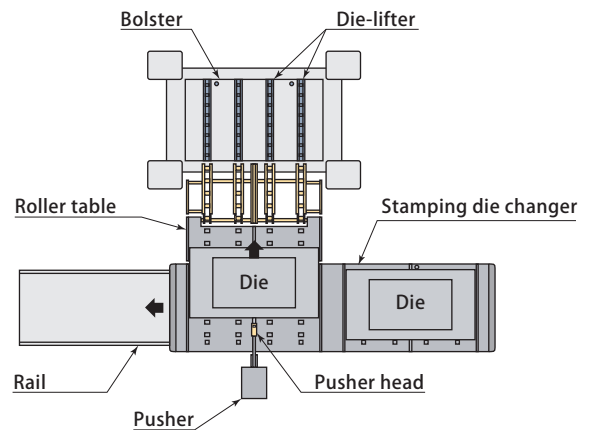

Auto coupler



1200ton hot press

By introduction of auto coupler, coupler and electrical connector such as hydraulic, cooling water and air etc can be engaged and de-engaged automatically at one touch of operation at the same time.

In addition to it, not only work efficiency during die change operation is improved but also human error such as connection mistake can be minimized.

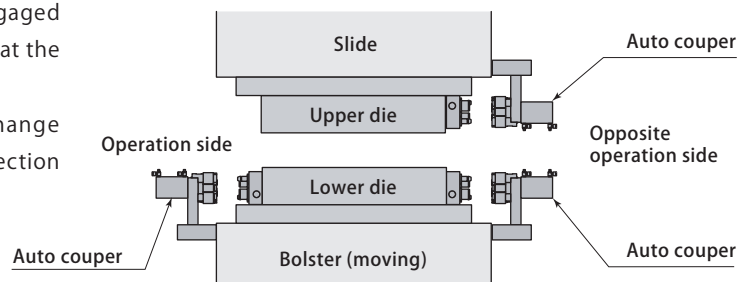

Mini gas spring

model **DSA**

Compact and durable N2 mini gas spring



4,000kN (400tonf) Progressive press mini gas spring model DSA Adopted example (photo left : upper, right : lower)

Operation panel

model **ELC-AJM11**

The upper/lower clamp and die-lifter can be operated by simple selector switch operation. Its control unit shall be installed inside the machine control panel.



Control panel
ELC-AJM11

Press mag clamp

Pascal mag clamp is a die clamping system which absorbs and fixes the die with strong everlasting magnets (Neodymium magnet Alnico magnet). It is unnecessary to unify the die size and it can clamp the die instantly at one touch operation. The electric power is required only when magnetizing and demagnetizing the clamp and the die will not be fall down due to the power failure. The clamping force works against the entire die surface, which prevents the deflection and improves the quality of pressed parts.



2,000kN (200tonf) High velocity press machine press mag clamp

Pascal all products

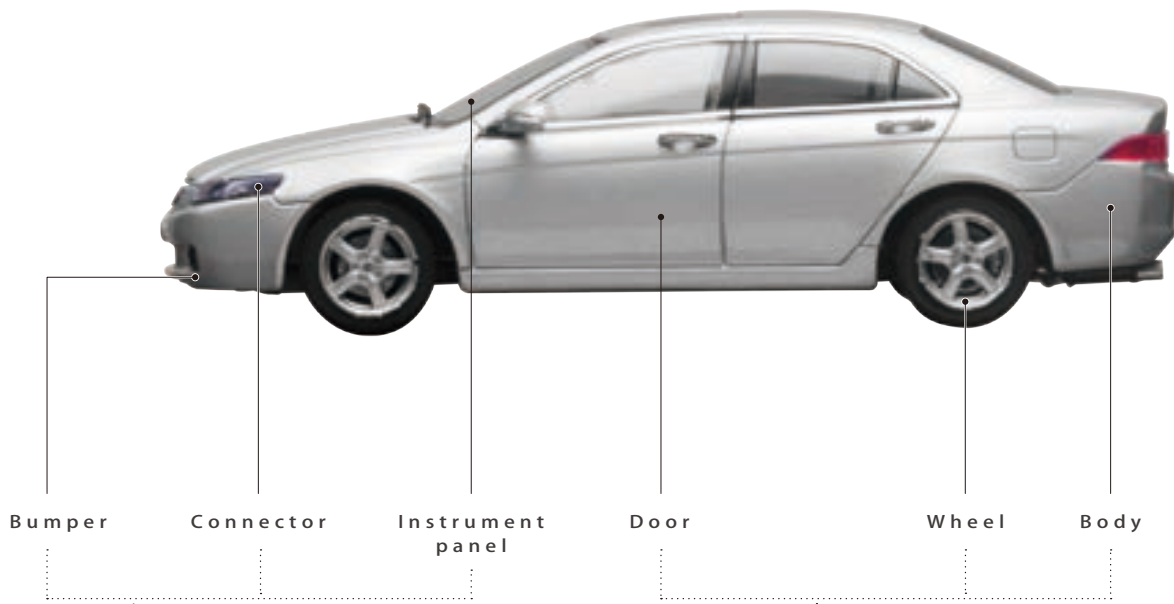

For plastic molding



Mag clamp



Mold die clamping system

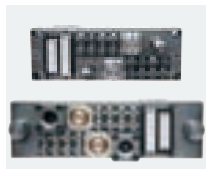

Auto coupler

For sheetmetal stamping



Traveling clamp



Stamping die clamp

For automotive parts die & mold



N2 gas springs

Press machine :
Body , Roof , Door
etc...

Molding machine :
Bumper ,
Instrument panel
etc...

Pascal products support automotive production lines globally.

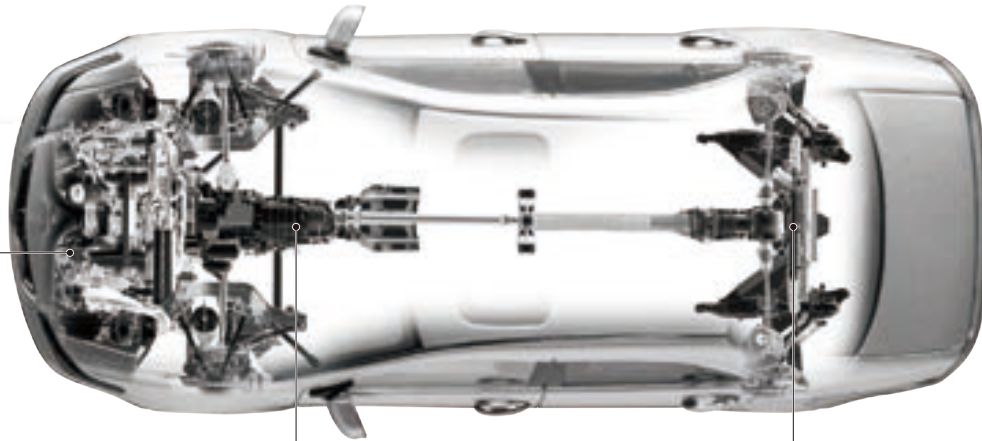

Engine

Transmission

Axle

For die cast machine



Die-clamping system



C-plate mag clamp

For metal cutting work



Work clamp



Pallet clamp



Index table



N2 gas balancer

DOMESTIC LOCATIONS

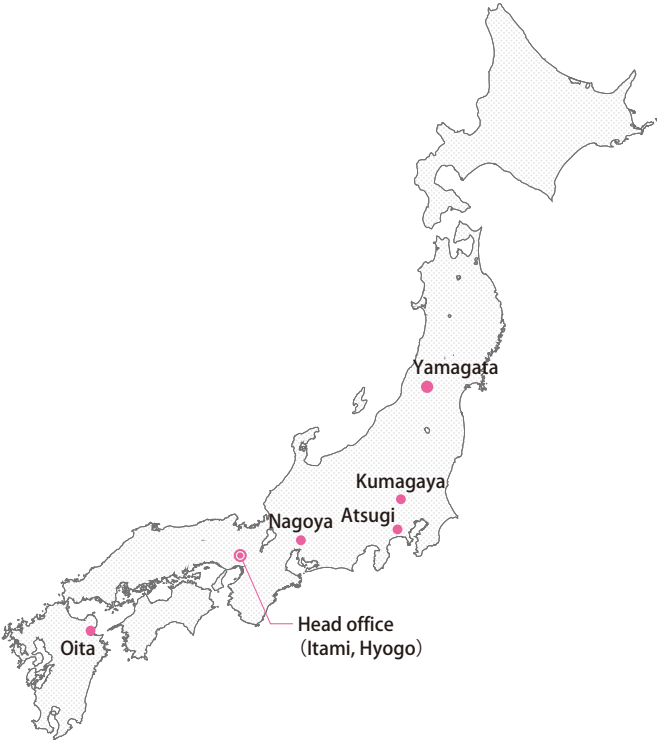

JAPAN

Head office / R & D center ● Itami, Hyogo

Sales office ● Osaka, Hyogo
 ● Kumagaya, Saitama,
 ● Atsugi, Kanagawa
 ● Nagoya, Aichi
 ● Yamagata

Plant ● Oita
 ● Yamagata



Head office / R & D center



Oita plant



Yamagata plant

GLOBAL NETWORK

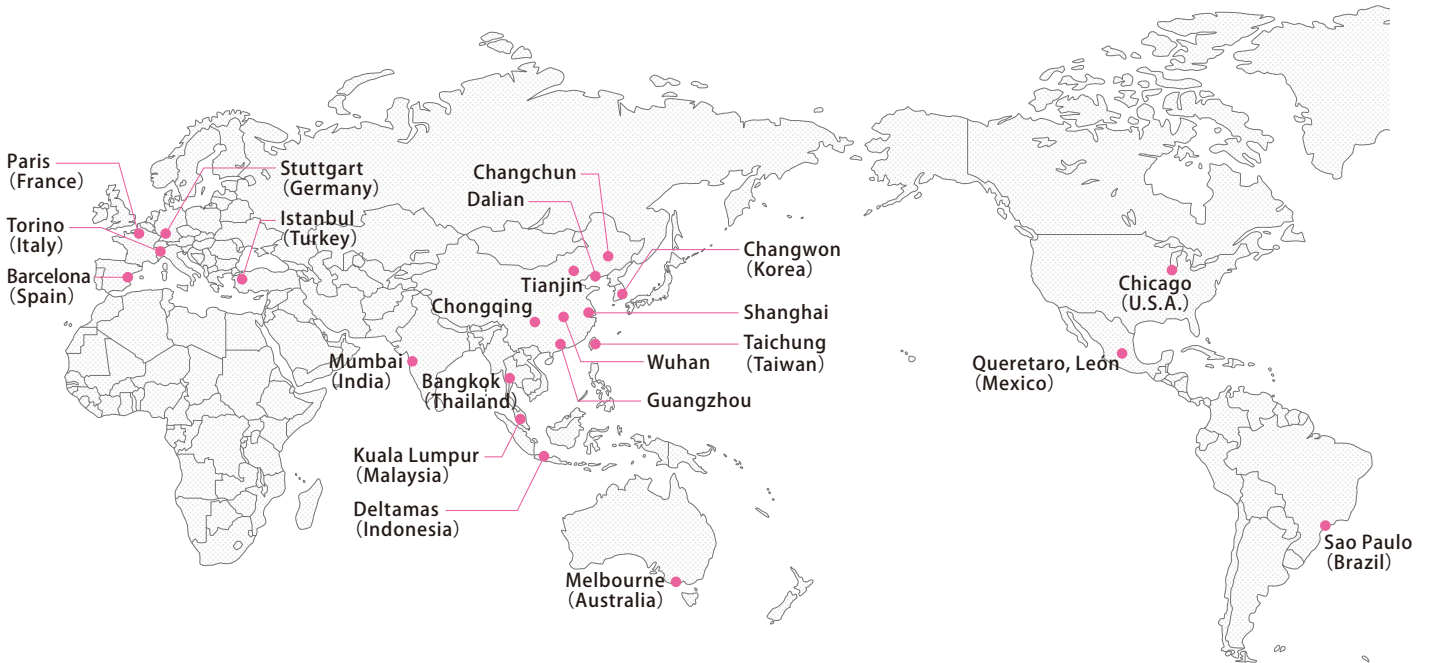

ASIA

- | | |
|------------------------|------------------------------|
| Dalian [China]
● | Taichung [Taiwan]
● |
| Shanghai [China]
● | Bangkok [Thailand]
● |
| Changchun [China]
● | Changwon [Korea]
● |
| Tianjin [China]
● | Deltamas [Indonesia]
○ |
| Wuhan [China]
● | Kuala Lumpur [Malaysia]
○ |
| Chongqing [China]
● | Mumbai [India]
○ |
| Guangzhou [China]
● | Melbourne [Australia]
○ |

● Plant ● Subsidiary ● Sales office ● Liaison office ○ Agent

AMERICA

- | |
|--------------------------------|
| Chicago [U.S.A.]
● |
| Queretaro , León [Mexico]
○ |
| Sao Paulo [Brazil]
○ |

EUROPE

- | |
|--------------------------|
| Stuttgart [Germany]
● |
| Torino [Italy]
○ |
| Paris [France]
○ |
| Barcelona [Spain]
○ |
| Istanbul [Turkey]
○ |

Pascal

corporation

Itami, Hyogo, Japan 664-8502
TEL. +81-72-777-3333 FAX. +81-72-777-3520

Chicago, U.S.A.	TEL. +1-847-427-1234
Stuttgart, Germany	TEL. +49-711-782-850-0
Dalian, China	TEL. +86-411-8732-2988
Shanghai, China	TEL. +86-21-5263-4122
Changwon, Korea	TEL. +82-55-274-0971
Bangkok, Thailand	TEL. +66-2173-5855

