

Pascal

**Stamping die changer
&
Mold die changer**

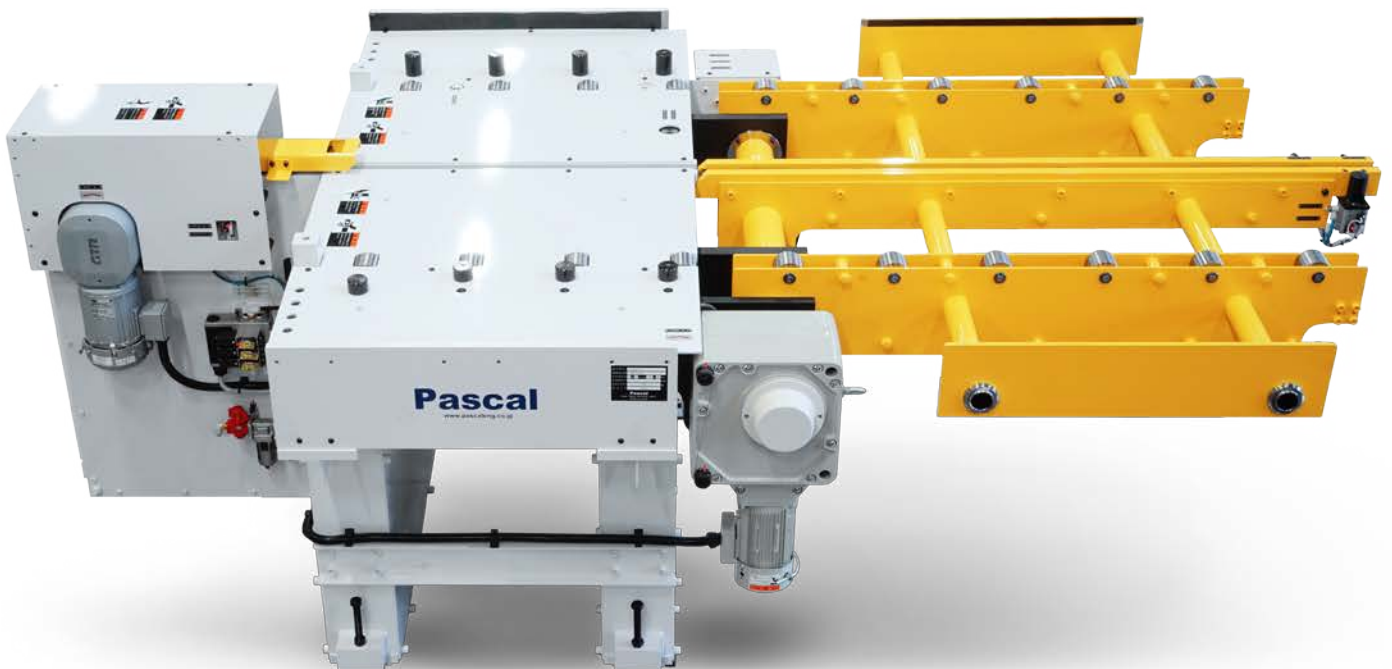

Stamping

2,000 kN press



die changer

Die 3 ton ×1 die

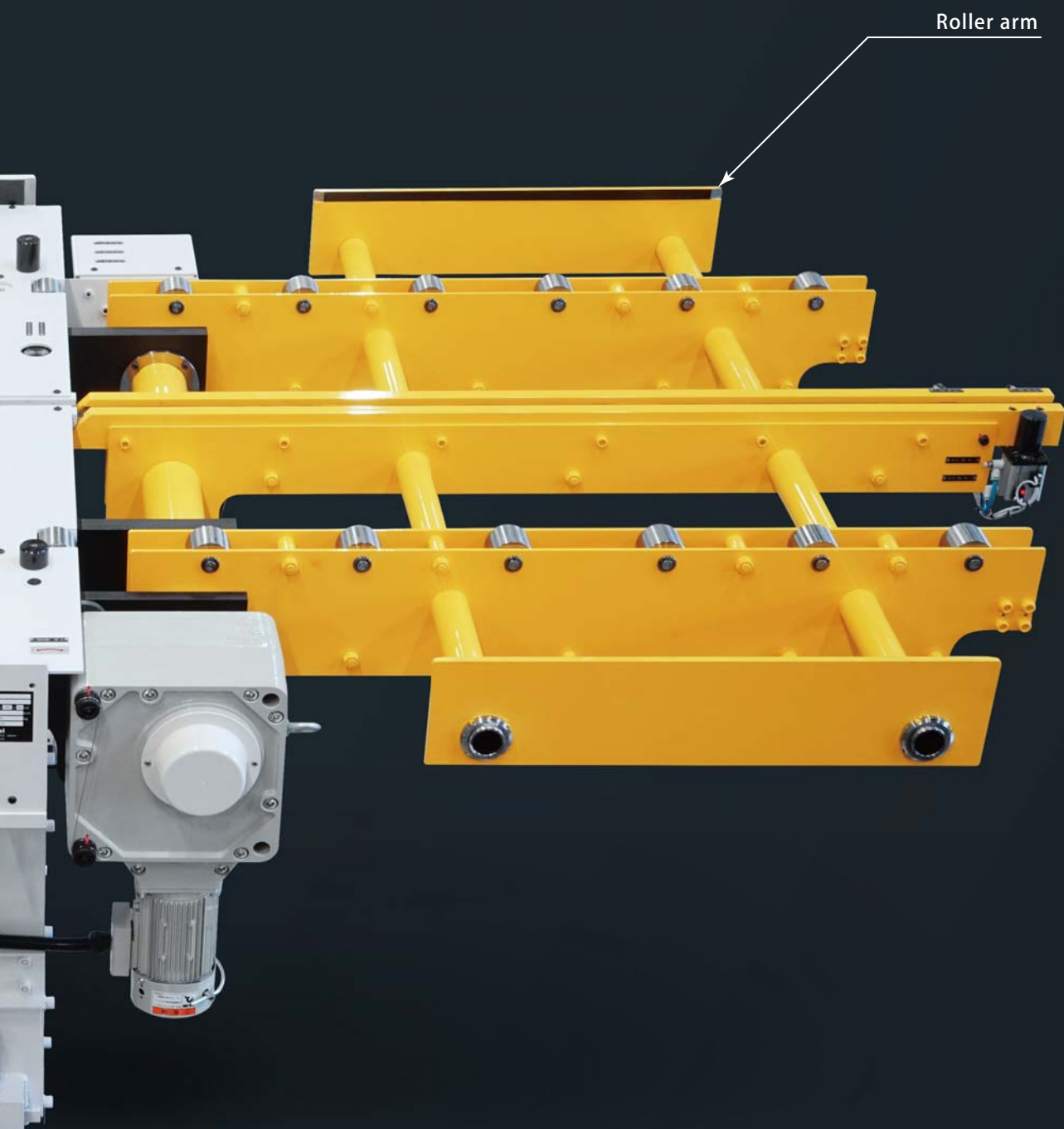

12,000kN press Die 12 ton × 2 dies

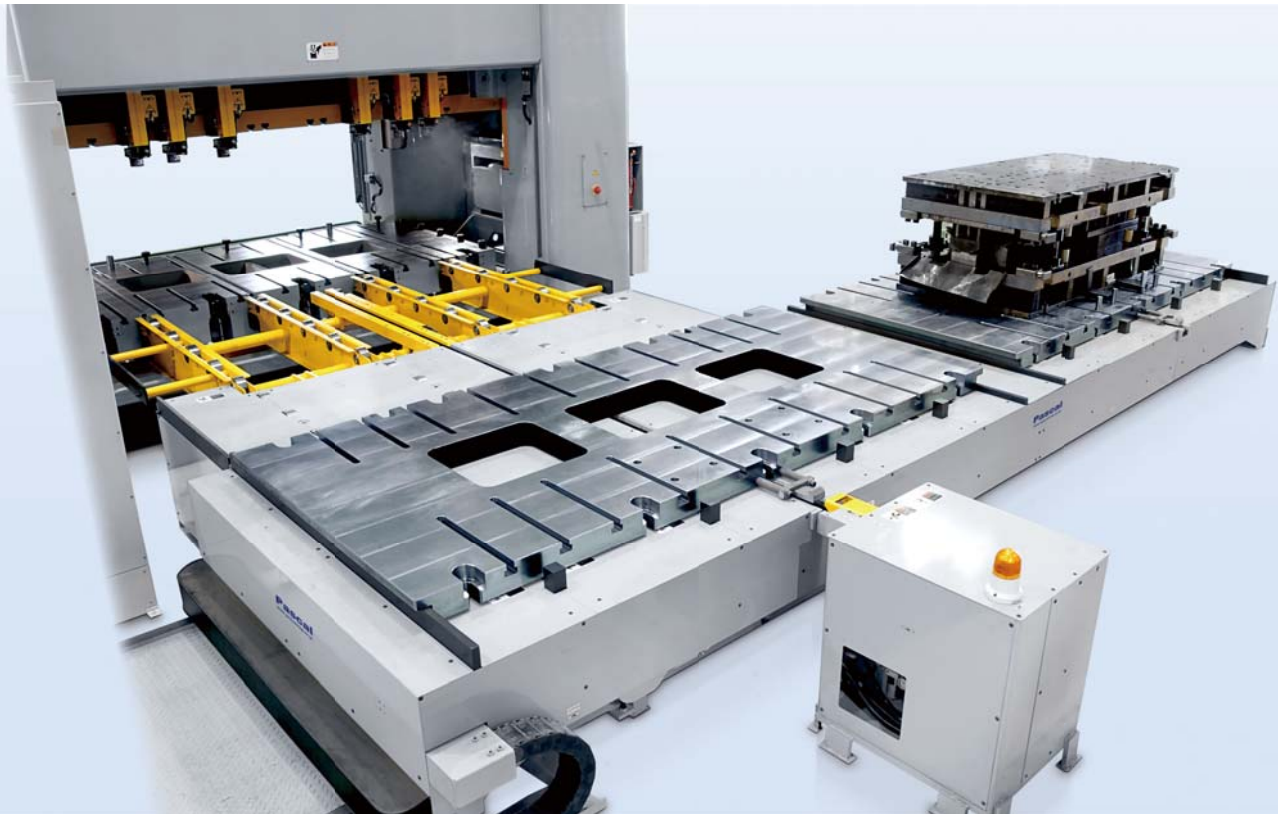

System configuration		Roller table+Swing roller Changer
Die loading		Pusher type
Capacity of press machine		12000 kN (1200 tonf)
Max. die weight		12 ton × 2 dies
Max. die size	mm	depth : 1400 × width : 3000
Changer traveling distance	m	3.3

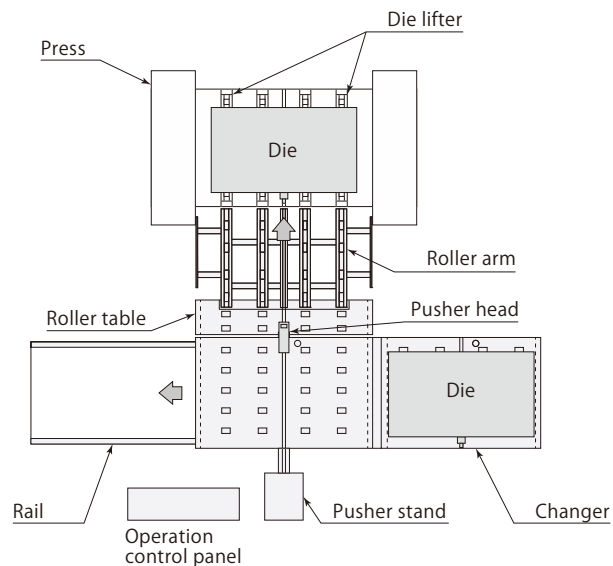

8,000kN press Die 2.8 ton × 2 dies



System configuration		Changer+Swing roller (no roller table)
Die loading		Pusher type
Capacity of press machine		8000 kN (800 tonf)
Max. die weight		2.8 ton × 2 dies
Max. die size	mm	depth : 1100 × width : 1700
Changer traveling distance	m	Overall length 4.6 (Pitch 2.3)

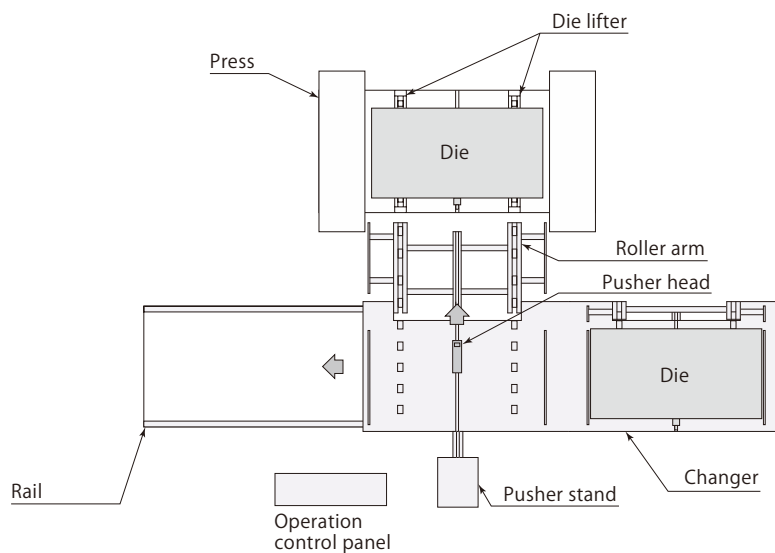

8,000kN press Die 20 ton × 1 die

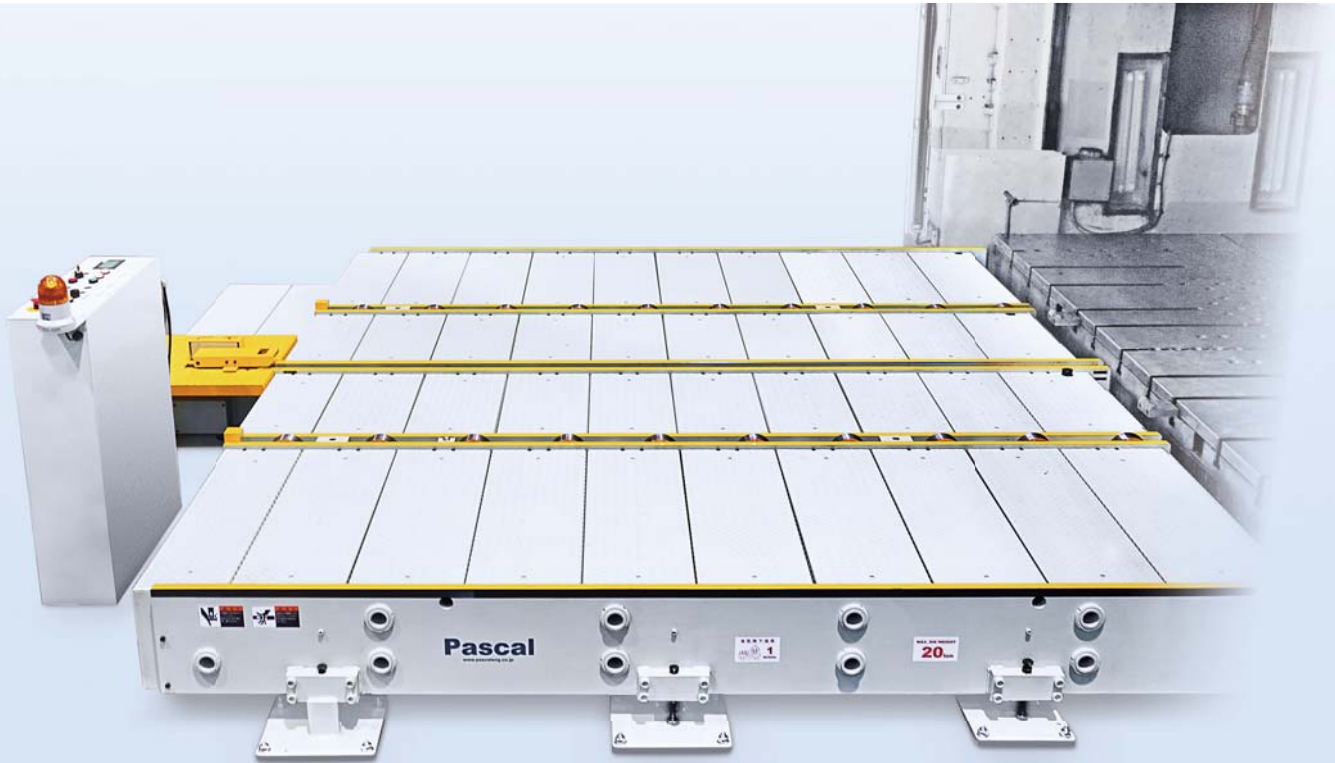

System configuration		Die stage
Die loading		Pusher type
Capacity of press machine		8000 kN (800 tonf)
Max. die weight		20 ton × 1 die
Max. die size	mm	depth : 2200 × width : 3700

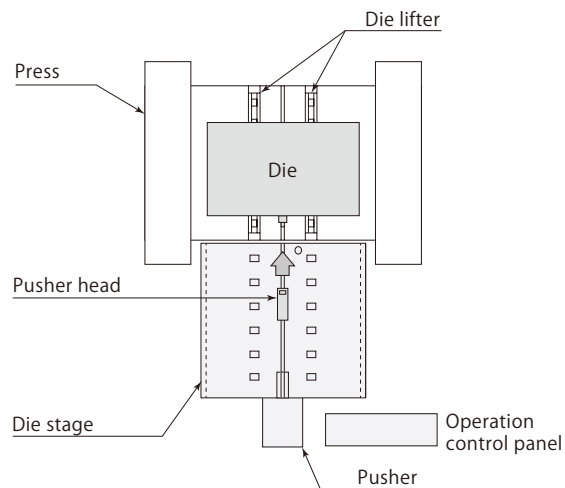

6,300kN press Die 10 ton × 1 die

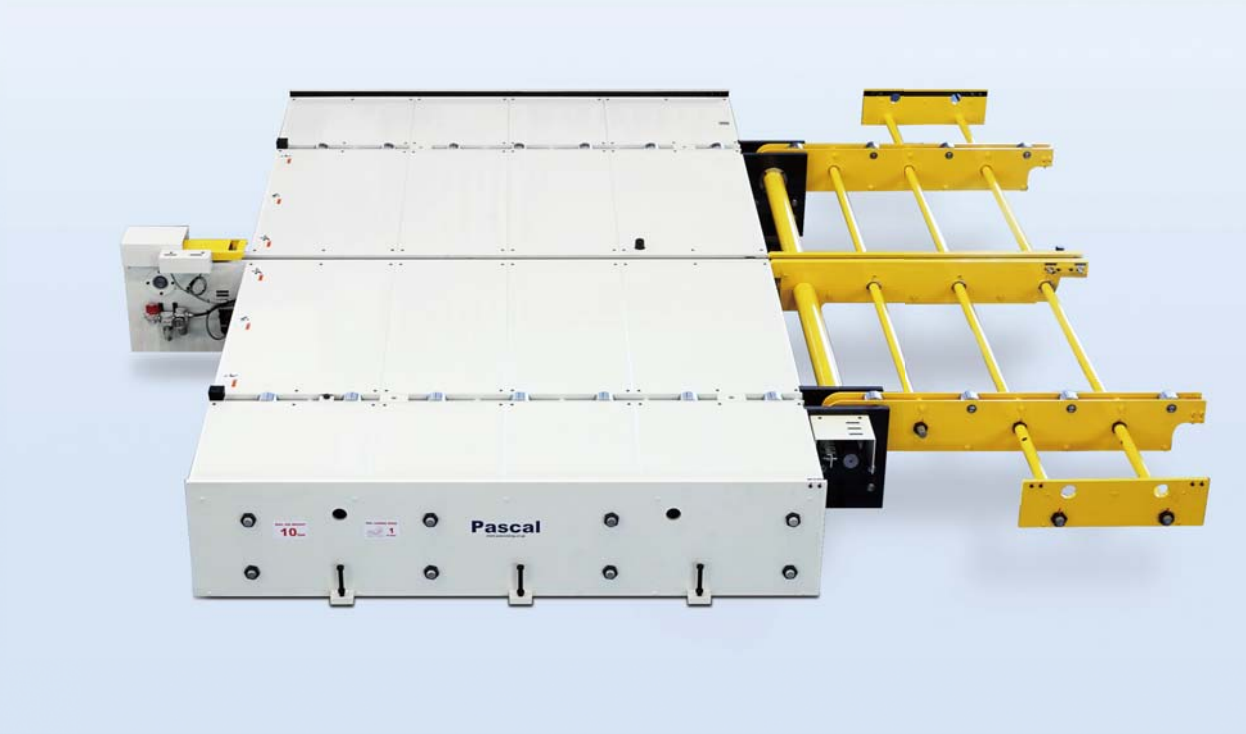

System configuration		Die stage+Swing roller
Die loading		Pusher type
Capacity of press machine		6300 kN (630 tonf)
Max. die weight		10 ton × 1 die
Max. die size	mm	depth : 1500 × width : 3650

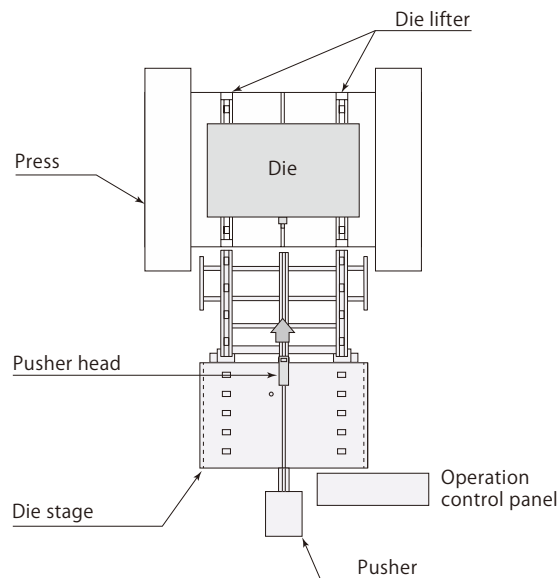

5,000kN press Die 6 ton × 1 die



System configuration		Roller table+Swing roller Changer
Die loading		Pusher type
Capacity of press machine		5000 kN (500 tonf)
Max. die weight		6 ton × 1 die
Max. die size	mm	depth : 900 × width : 2800
Changer traveling distance	m	Overall length 4.5

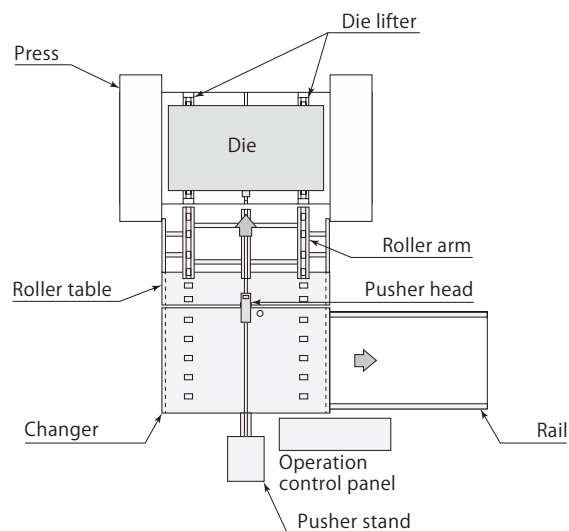

3,000kN press Die 4 ton × 2 dies



System configuration		Roller table Changer
Die loading		Pusher type
Capacity of press machine		3000 kN (300 tonf)
Max. die weight		4 ton × 2 dies
Max. die size	mm	depth : 800 × width : 2100
Changer traveling distance	m	2.3

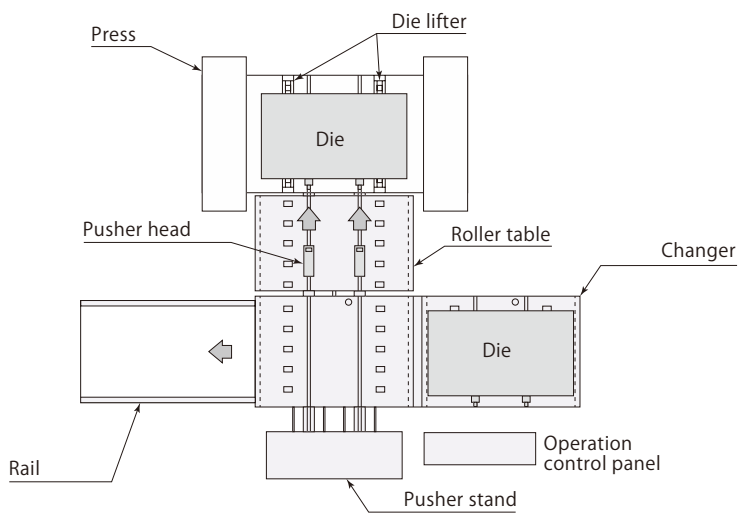

3,000kN press Die 4 ton × 2 dies



System configuration		Roller table Changer
Die loading		Pusher type
Capacity of press machine		3000 kN (300 tonf)
Max. die weight		4 ton × 2 dies
Max. die size	mm	depth : 800 × width : 2100
Changer traveling distance	m	2.3

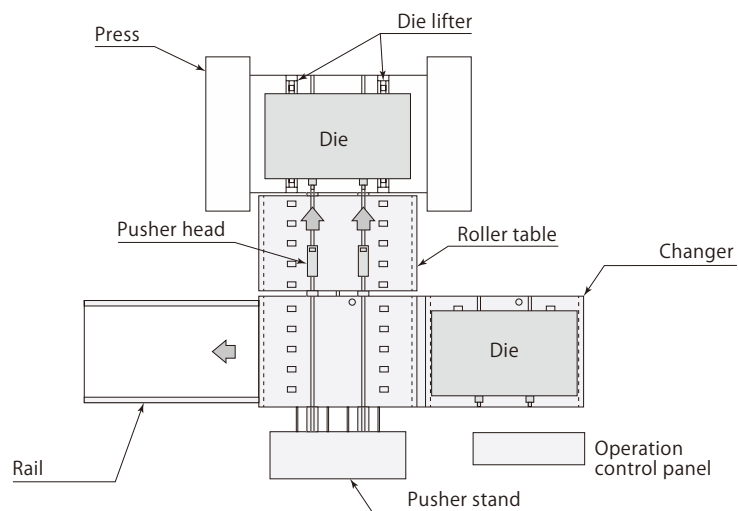

3,000kN press Die 2.5 ton × 2 dies



System configuration		Roller table Changer
Die loading		Pusher type
Capacity of press machine		3000 kN (300 tonf)
Max. die weight		2.5 ton × 2 dies
Max. die size	mm	depth : 700 × width : 1700
Changer traveling distance	m	1.9

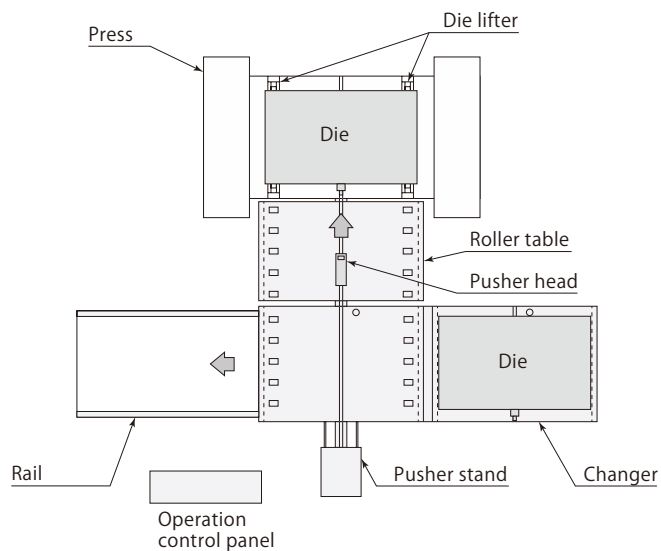

3,000kN press Die 0.5 ton × 12 dies



System configuration		Roller table Changer
Die loading		Pusher type
Capacity of press machine		3000 kN (300 tonf)
Max. die weight		0.5 ton × 12 dies
Max. die size	mm	depth : 700 × width : 800
Changer traveling distance	m	0.11

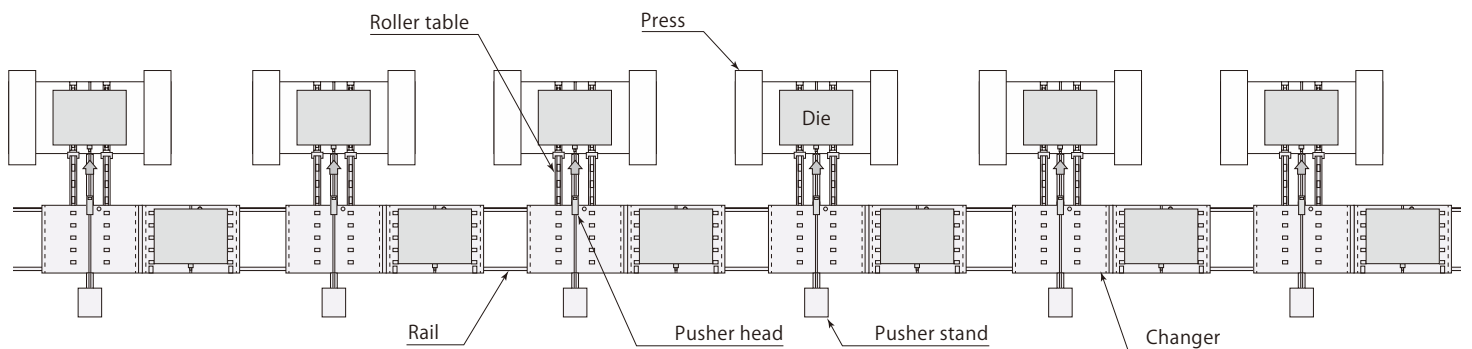

3,000kN press Die 5 ton × 2 dies

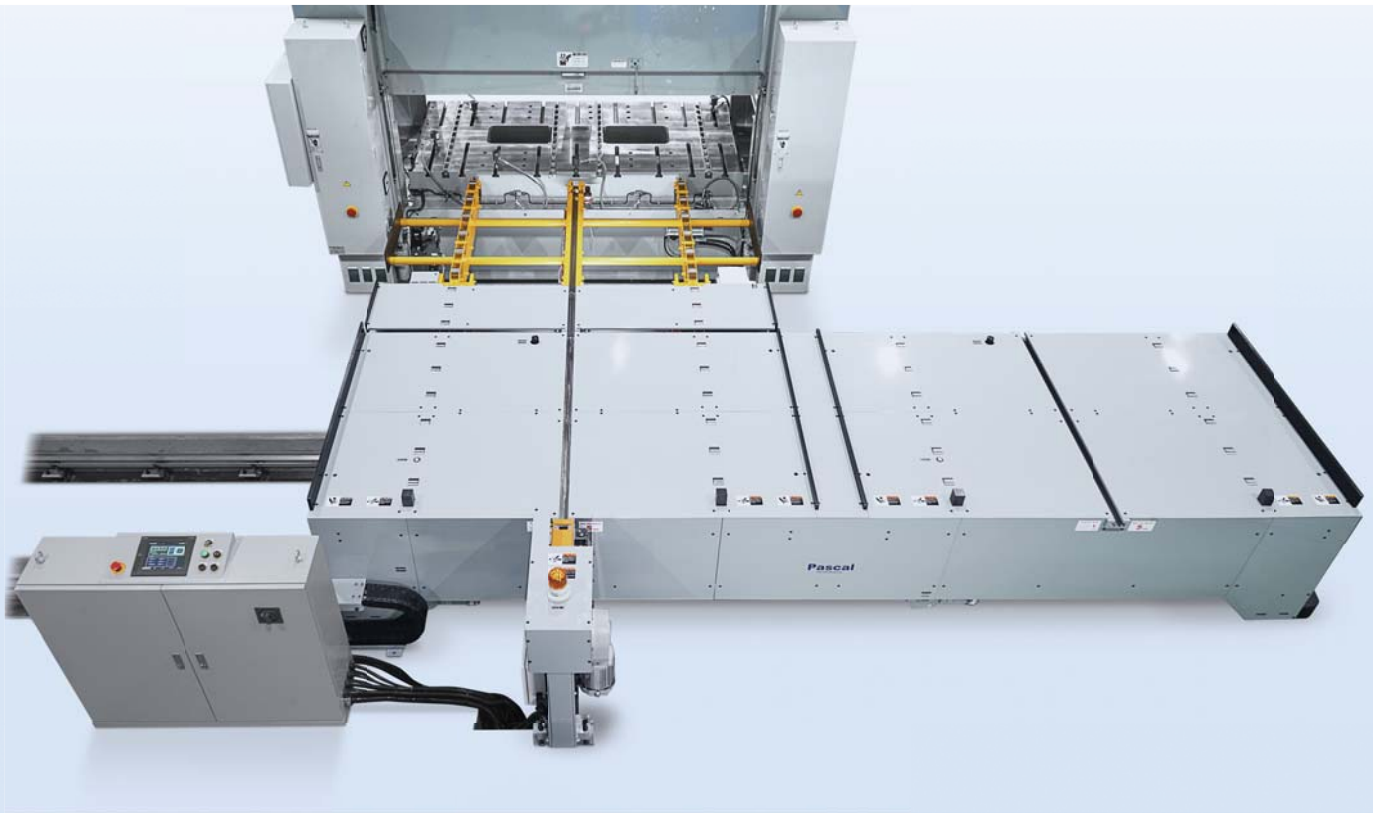

System configuration		Roller table+Swing roller Changer
Die loading		Pusher type
Capacity of press machine		3000 kN (300 tonf)
Max. die weight		5 ton × 2 dies
Max. die size	mm	depth : 1200 × width : 2450
Changer traveling distance	m	2.65

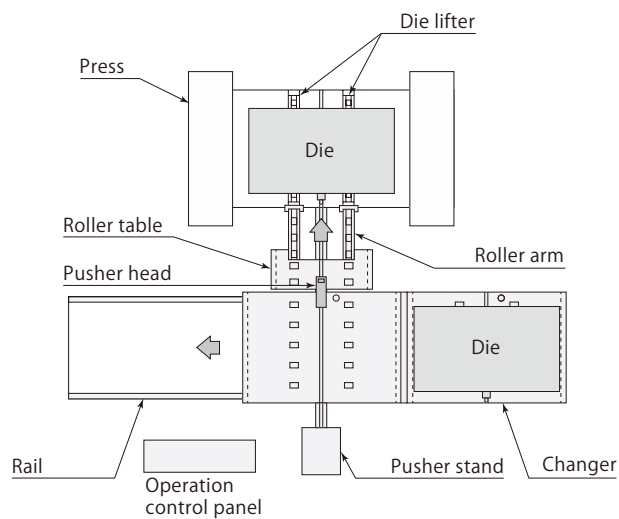

2,500kN press Die 3 ton × 2 dies

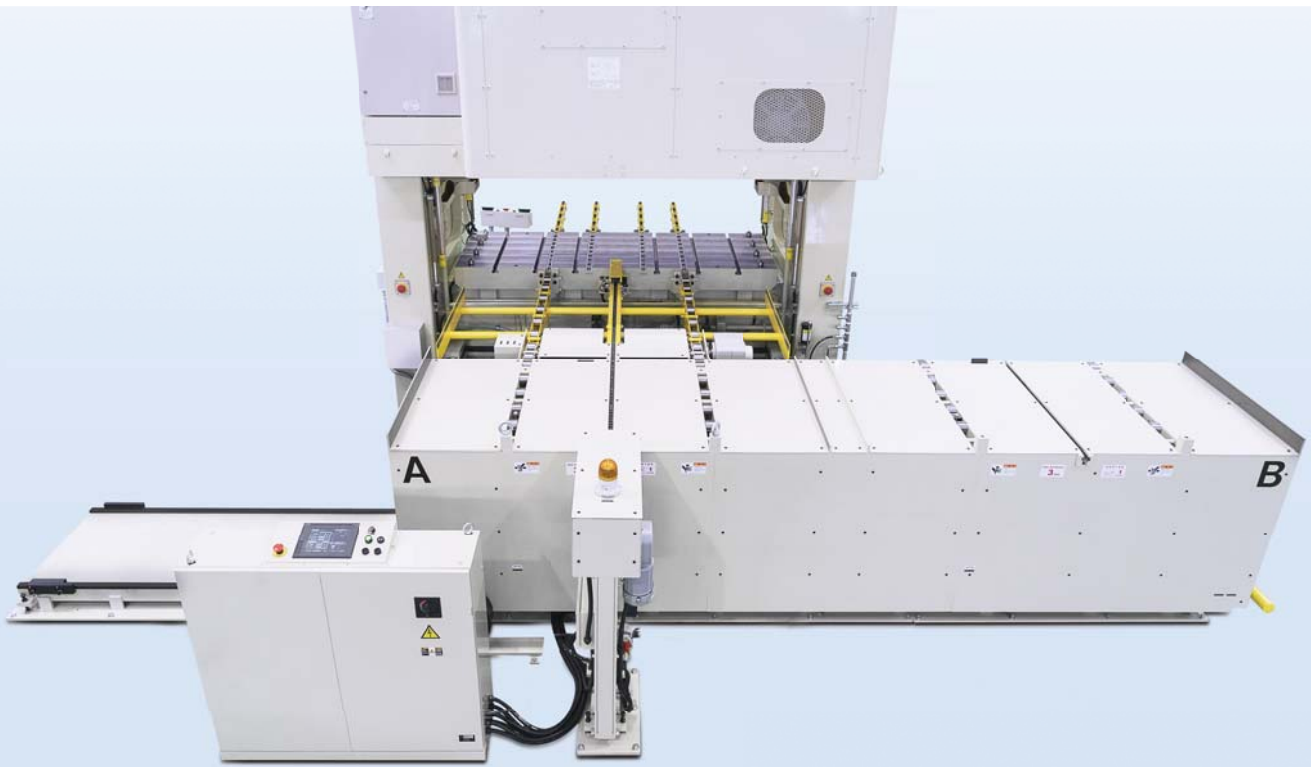

System configuration		Roller table+Swing roller Changer
Die loading		Pusher type
Capacity of press machine		2500 kN (250 tonf)
Max. die weight		3 ton × 2 dies
Max. die size	mm	depth : 910 × width : 2100
Changer traveling distance	m	2.3

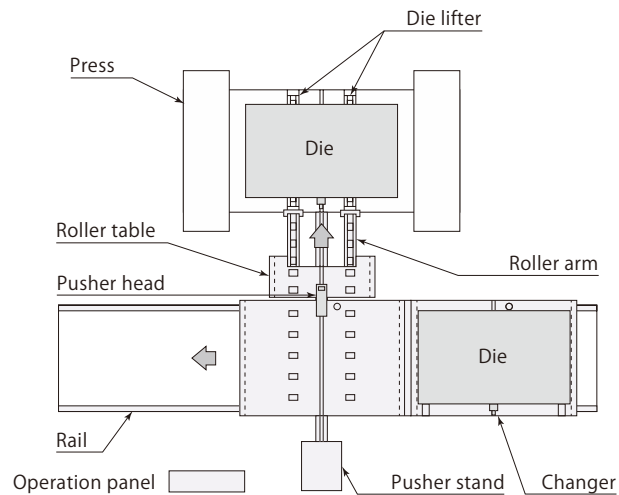

2,500kN press Die 2.5 ton × 2 dies



System configuration		Roller table+Swing roller Changer
Die loading		Pusher type
Capacity of press machine		2500 kN (250 tonf)
Max. die weight		2.5 ton × 2 dies
Max. die size	mm	depth : 800 × width : 2400
Changer traveling distance	m	2.6

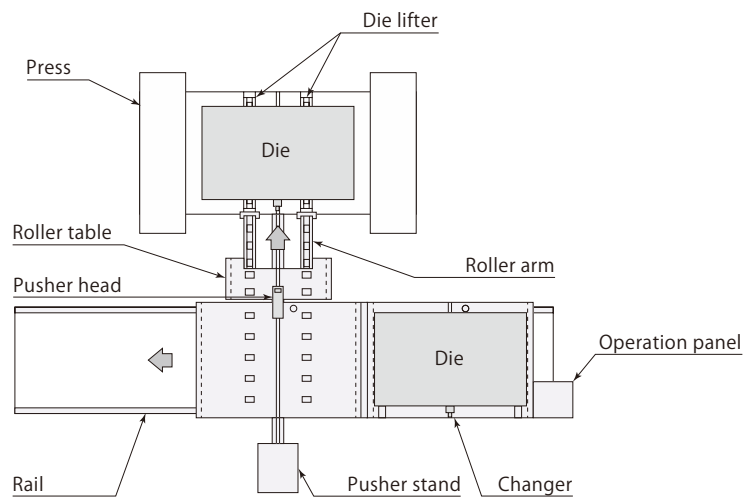

2,000kN press Die 3 ton × 1 die



System configuration		Die stage+Swing roller
Die loading		Pusher type
Capacity of press machine		2000 kN (200 tonf)
Max. die weight		3 ton × 1 die
Max. die size	mm	depth : 650 × width : 1540

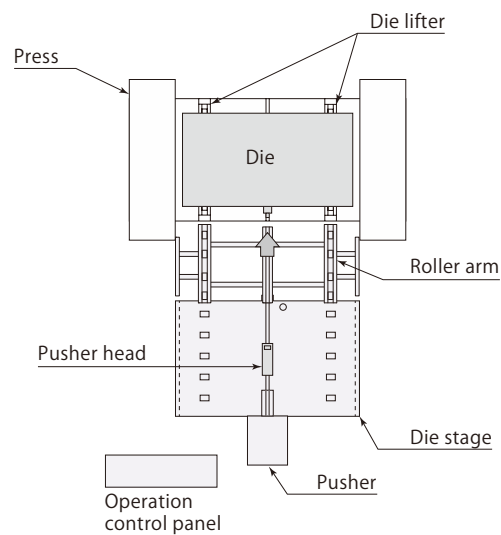

● Fill out the following table for a quotation.

Press machine	
Model of press machine	
Capacity of press machine	
New	Existing

Die	
Max. die weight	
Max. die size	

● Select among layout 1 to 3 when 2-station shuttle type of changer is required.

1 Roller table Changer

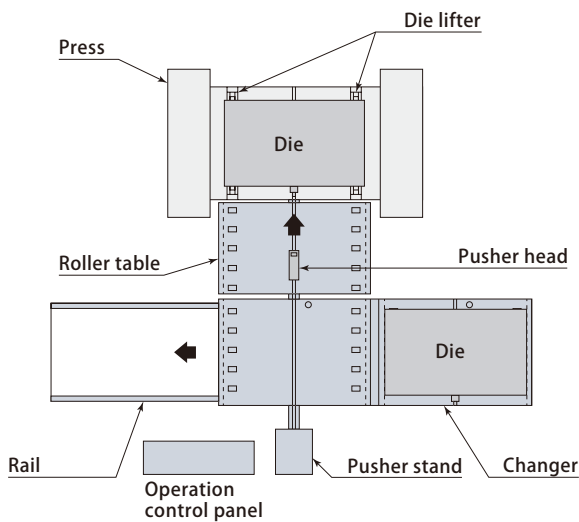

2 Roller table+Swing roller Changer

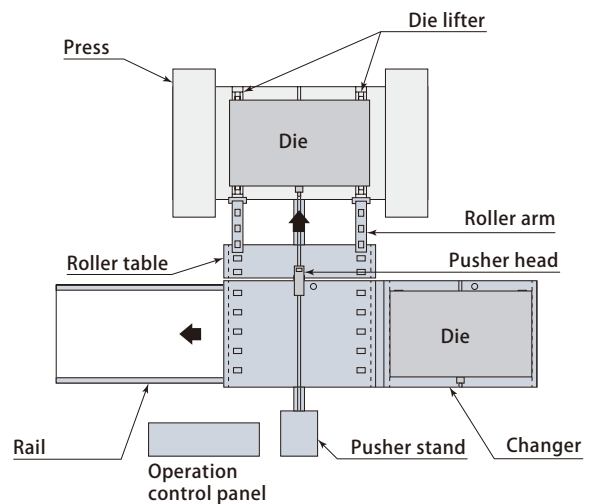

3 Changer+Swing roller (no roller table)

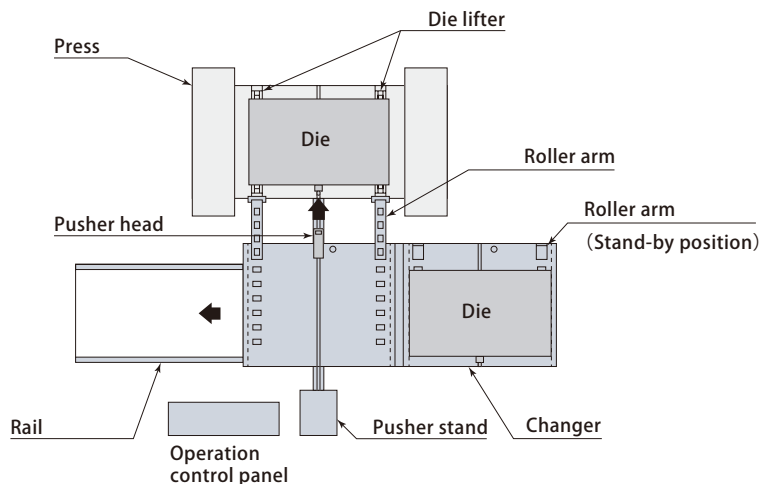

Mold changer & Mag clamp

30,000 kN IMM Mold 30 ton × 2 molds

Mold changer

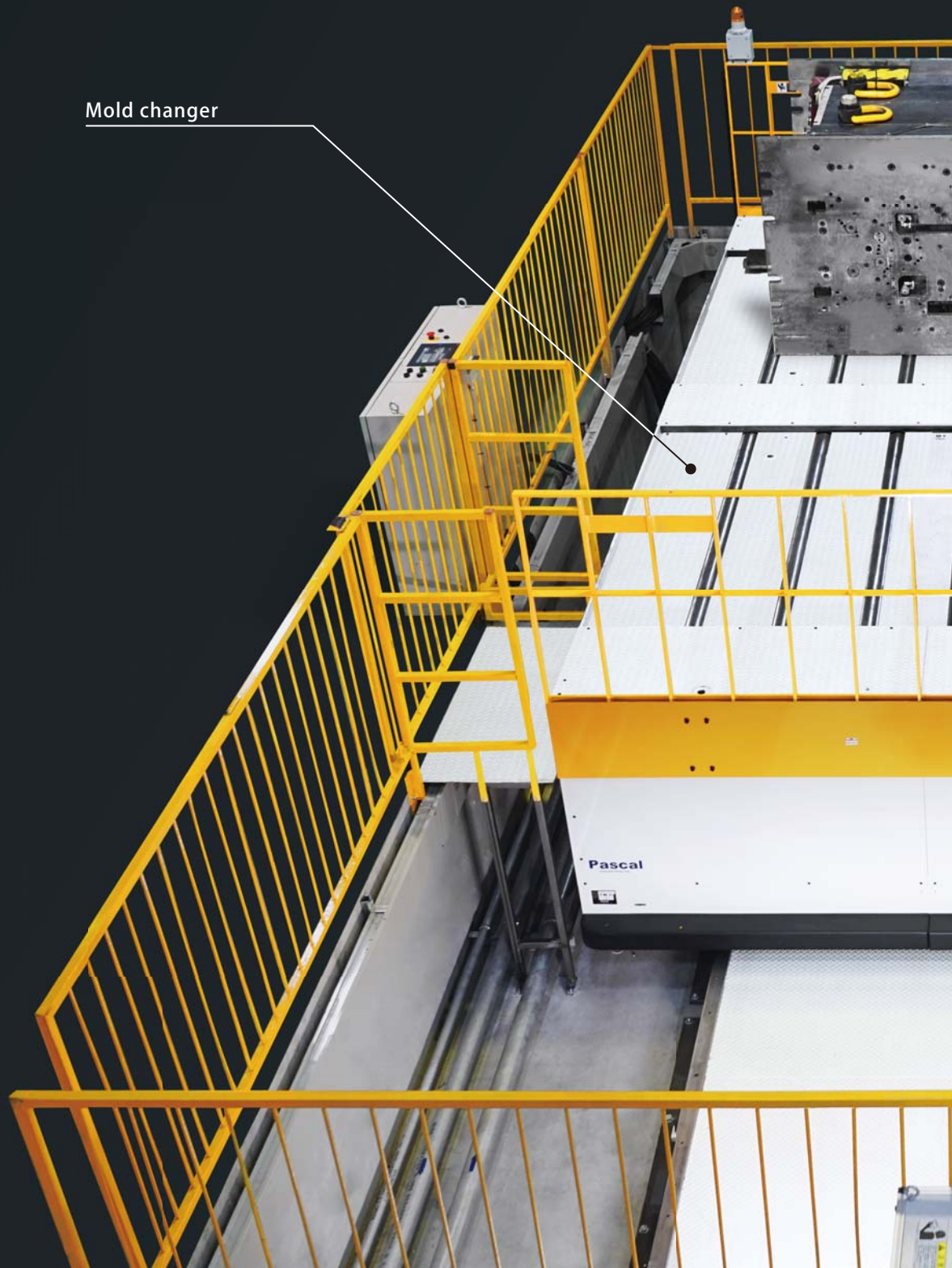

Mag clamp

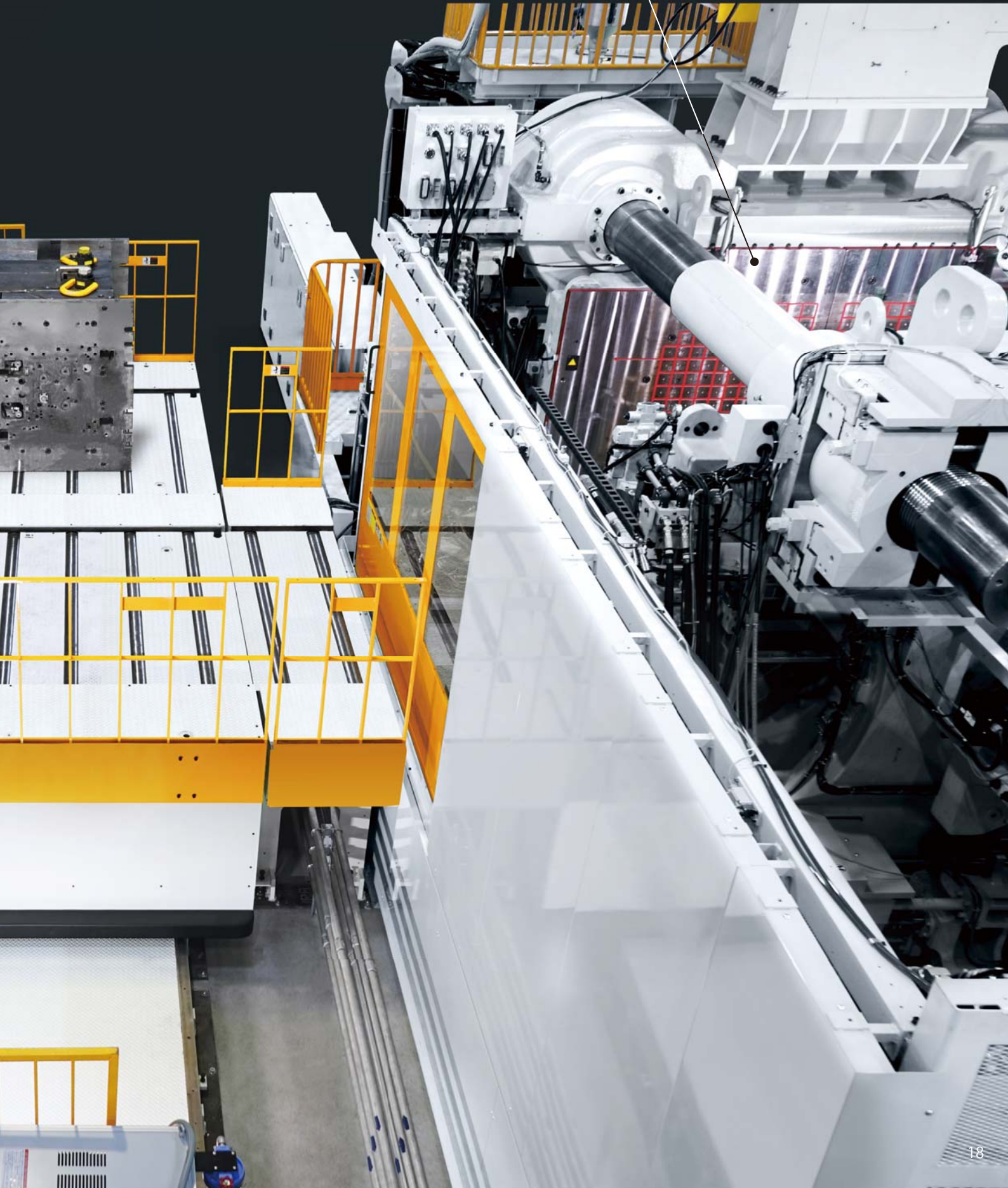

30,000kN IMM Mold 30 ton × 2 molds



Changer travel		Powered, On the rail
Mold loading		Drive rollers type
Clamping force of IMM		30000 kN (3000 tonf)
Max. mold weight		30 ton × 2 molds
Max. mold size	mm	depth : 1900 × height : 1560 × width : 2800
Changer traveling distance	m	3.105

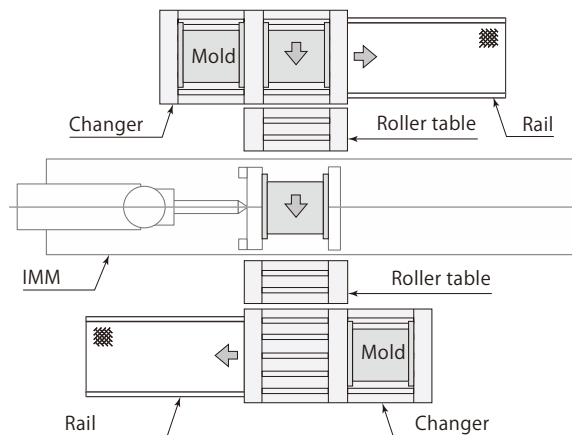

30,000kN IMM Mold 30 ton × 2 molds

Mold changer

Mag clamp

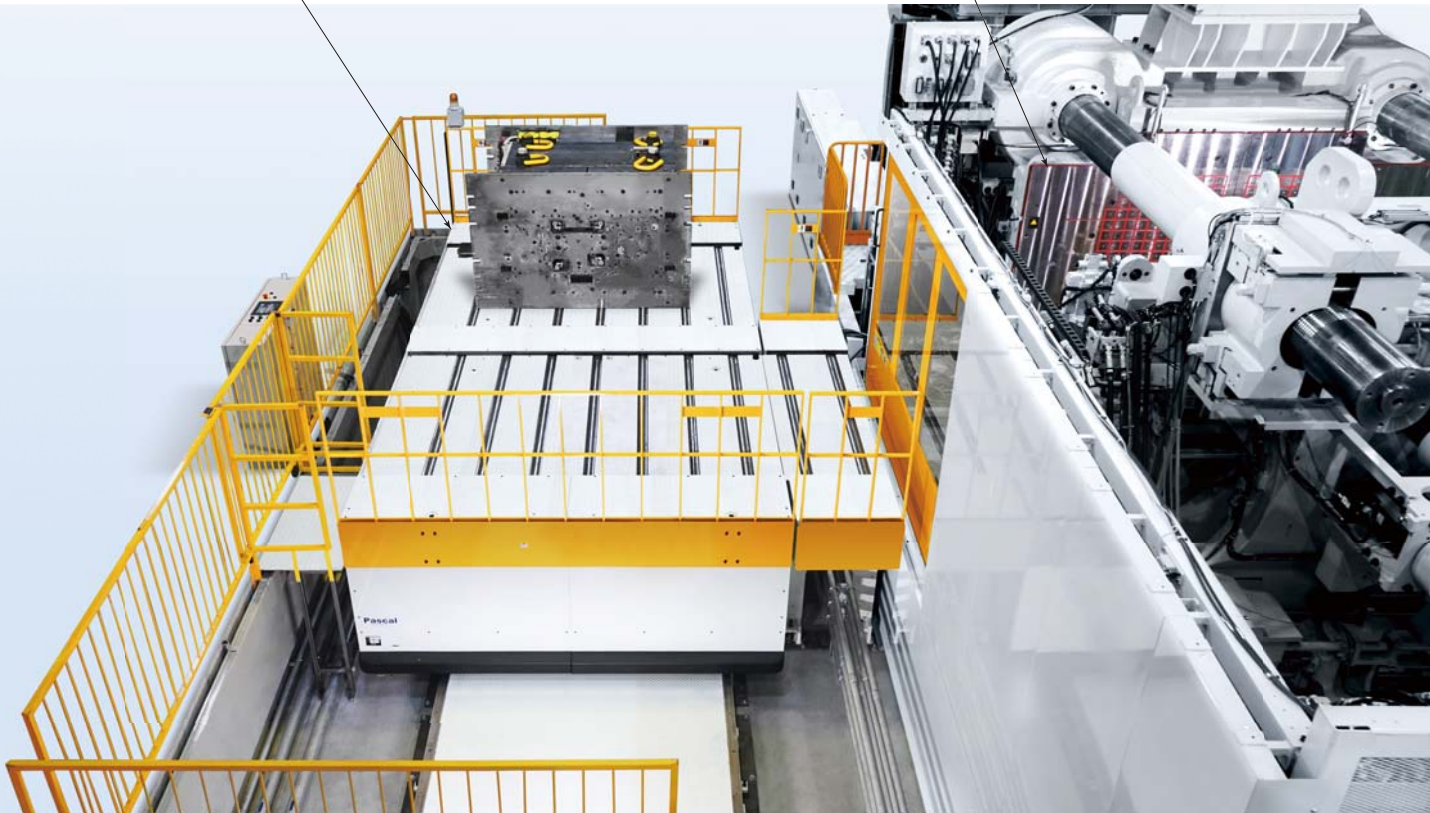

Changer travel		Powered, On the rail
Mold loading		Drive rollers type
Clamping force of IMM		30000 kN (3000 tonf)
Max. mold weight		30 ton × 2 molds
Max. mold size	mm	depth : 2800 × height : 1600 × width : 1900
Changer traveling distance	m	2.4

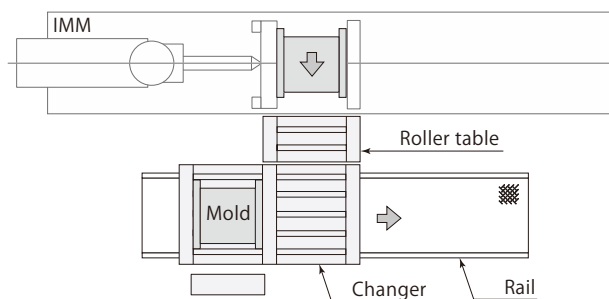

Operation control panel

13,000kN IMM Mold 15 ton × 2 molds

Mold changer

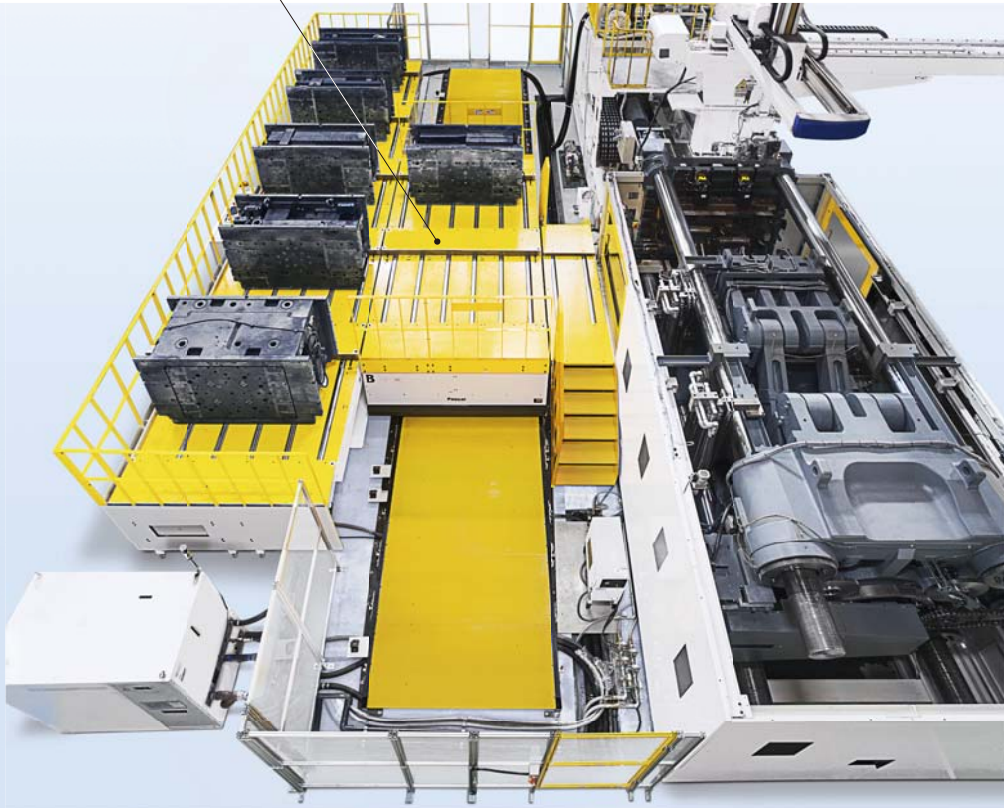

Changer travel		Powered, On the rail
Mold loading		Drive rollers type
Clamping force of IMM		13000 kN (1300 tonf)
Max. mold weight		15 ton × 2 molds
Max. mold size	mm	depth : 1300 × height : 1095 × width : 2000
Changer traveling distance	m	1.9

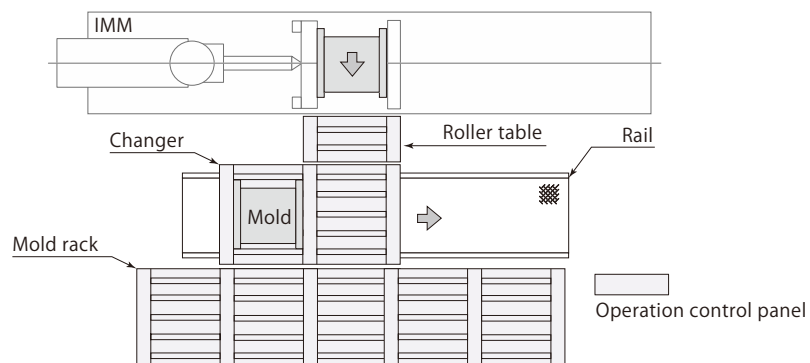

6,500kN IMM Mold 8 ton × 1 mold

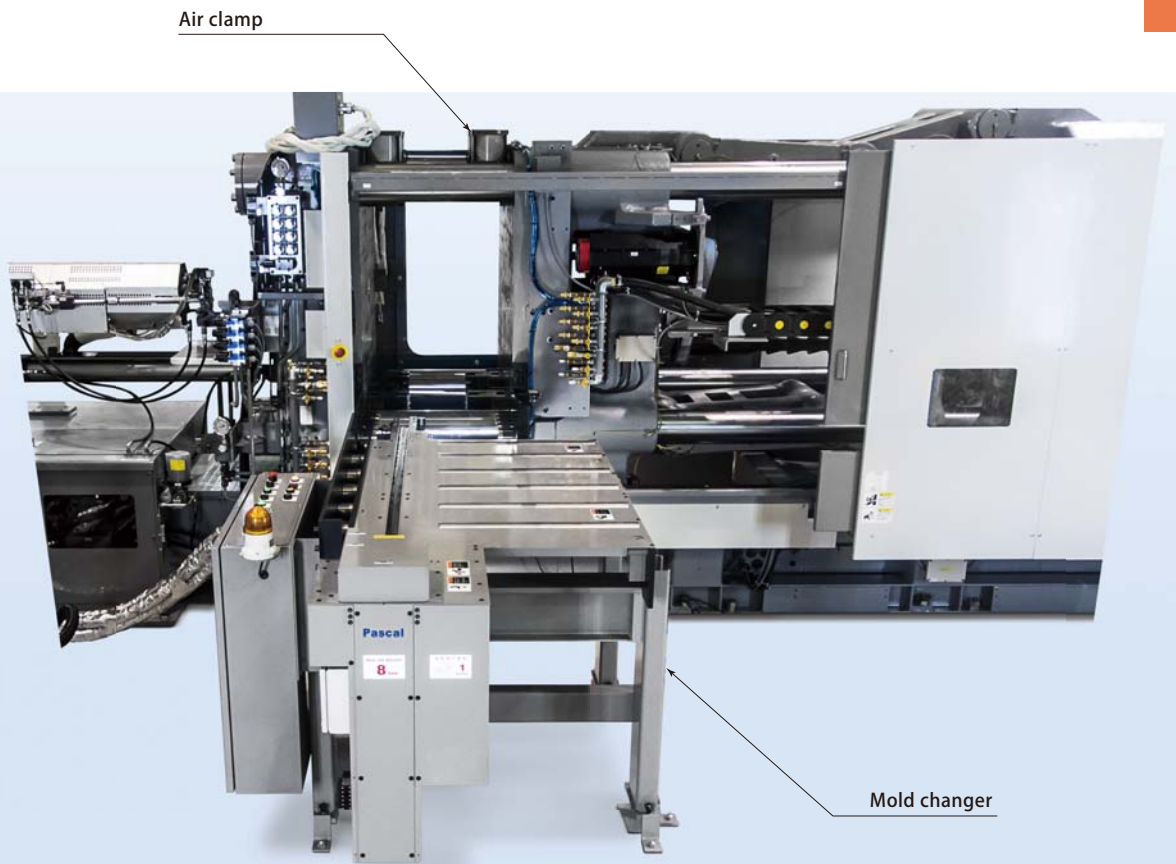

Die stage	
Mold loading	Pusher type
Clamping force of IMM	6500 kN (650 tonf)
Max. mold weight	8 ton × 1 mold
Max. mold size	mm depth : 1300 × height : 900 × width : 1000

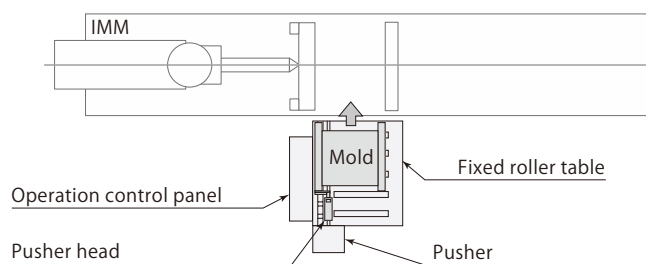

6,500kN IMM Mold 5 ton × 2 molds



Changer travel		Powered, On the rail
Mold loading		Drive rollers type
Clamping force of IMM		6500 kN (650 tonf)
Max. mold weight		5 ton × 2 molds
Max. mold size	mm	depth : 950 × height : 1080 × width : 1540
Changer traveling distance	m	1.25

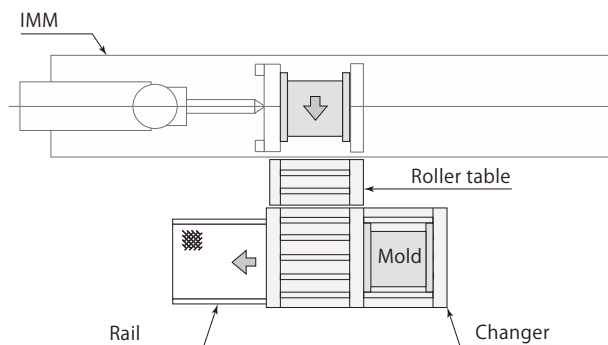



Changer travel		Powered, On the rail
Mold loading		Drive rollers type
Clamping force of IMM		4500 kN (450 tonf)
Max. mold weight		4 ton × 2 molds
Max. mold size	mm	depth : 900 × height : 700 × width : 800
Changer traveling distance	m	1.1

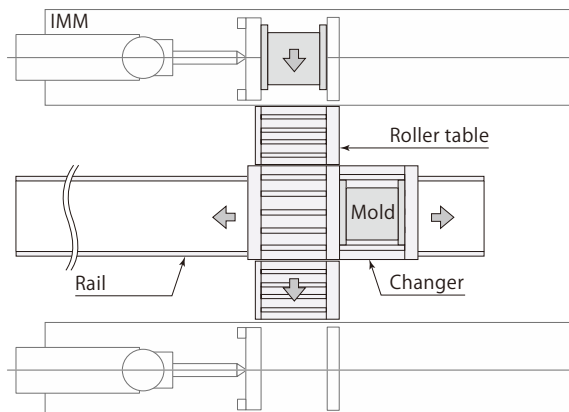

4,500kN IMM Mold 4 ton × 2 molds

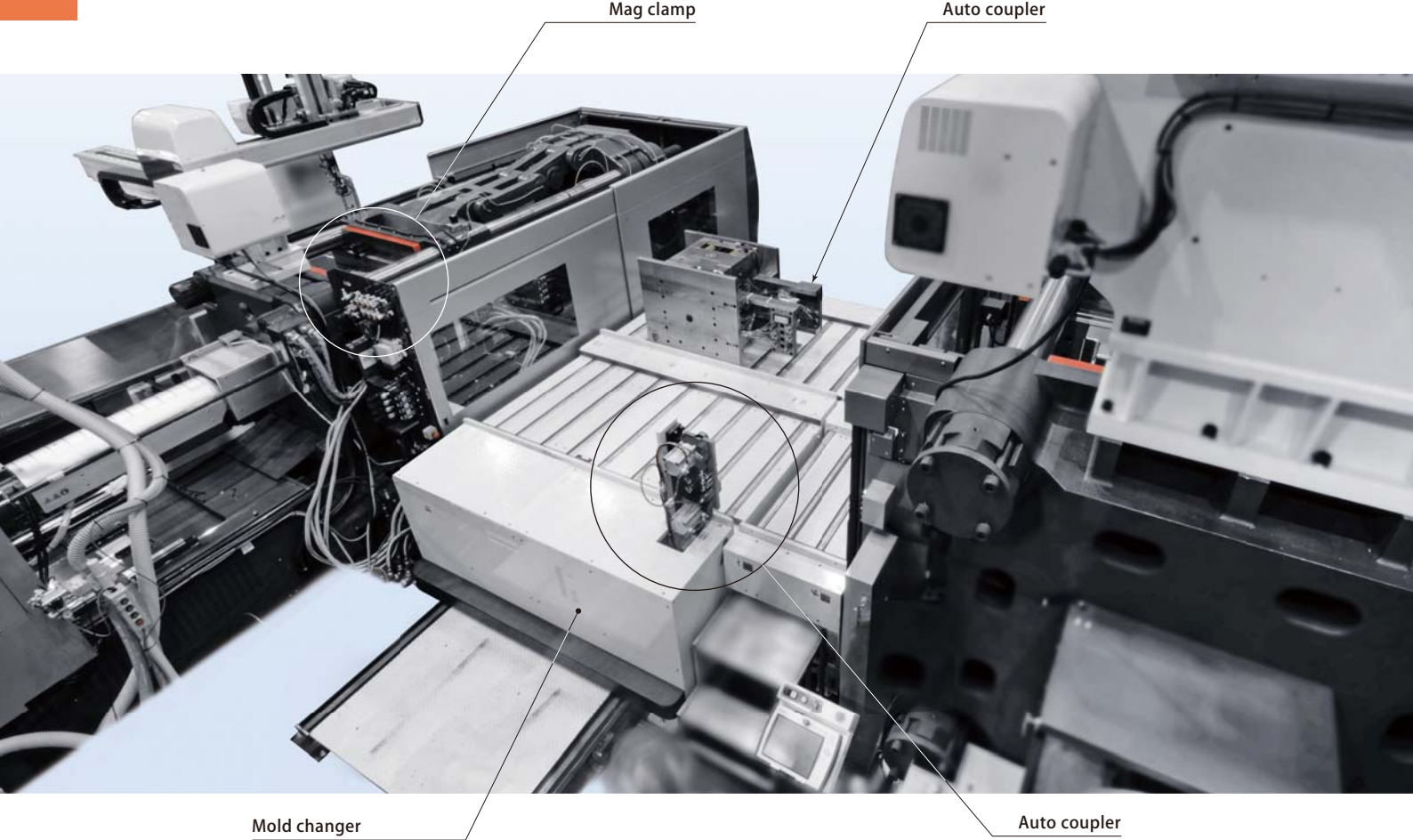

Changer travel		Powered, On the rail
Mold loading		Drive rollers type
Clamping force of IMM		4500 kN (450 tonf)
Max. mold weight		4 ton × 2 molds
Max. mold size	mm	depth : 1180 × height : 810 × width : 800
Changer traveling distance	m	1.4

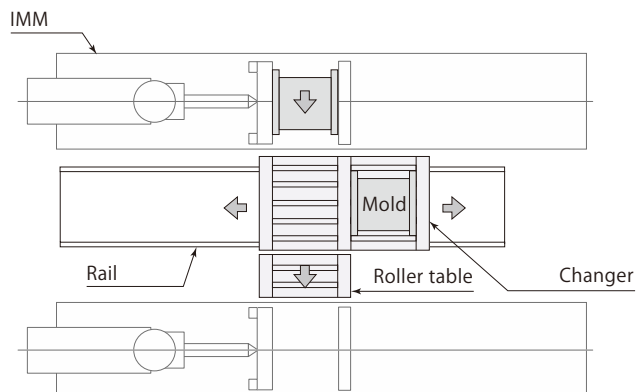



Changer travel		Powered, On the rail
Mold loading		Drive rollers type
Clamping force of IMM		3,850 kN (385 tonf)
Max. mold weight		2.2 ton × 2 molds
Max. mold size	mm	depth : 670 × height : 810 × width : 255

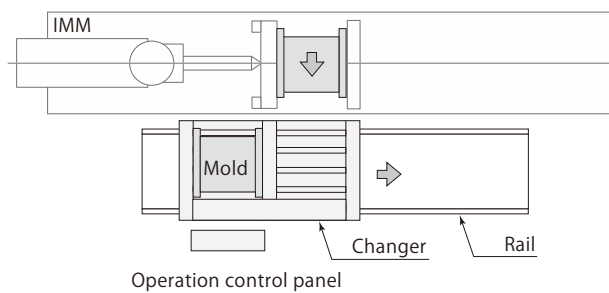

3,000kN IMM Mold 1500 kg × 2 molds

model **QME**

Mag clamp

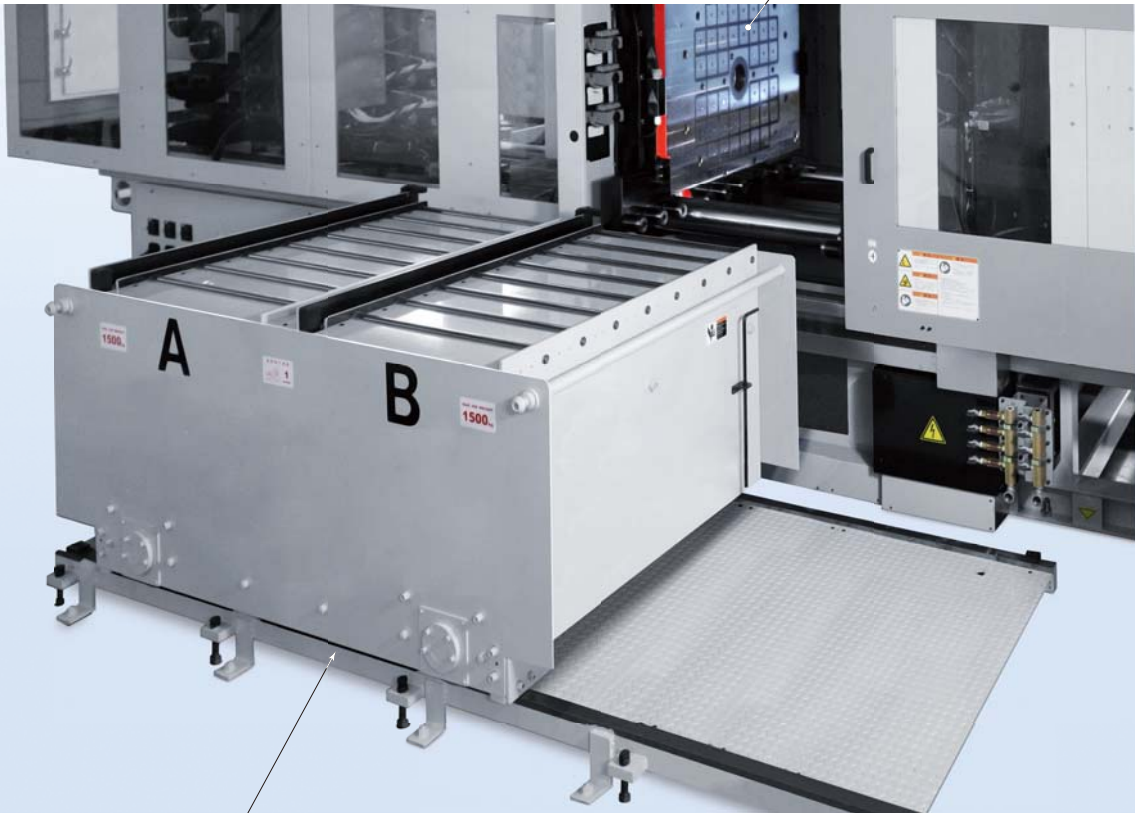

Mold changer

Changer travel		Manual, On the rail
Mold loading		Manual loading
Clamping force of IMM		3000 kN (300 tonf)
Max. mold weight		1500 kg × 2 molds
Max. mold size	mm	depth : 650 × height : 700 × width : 1130
Changer traveling distance	m	0.85

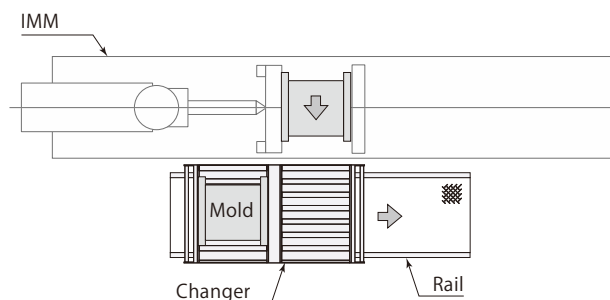

2,500kN IMM Mold 600 kg × 2 molds

model **QME**

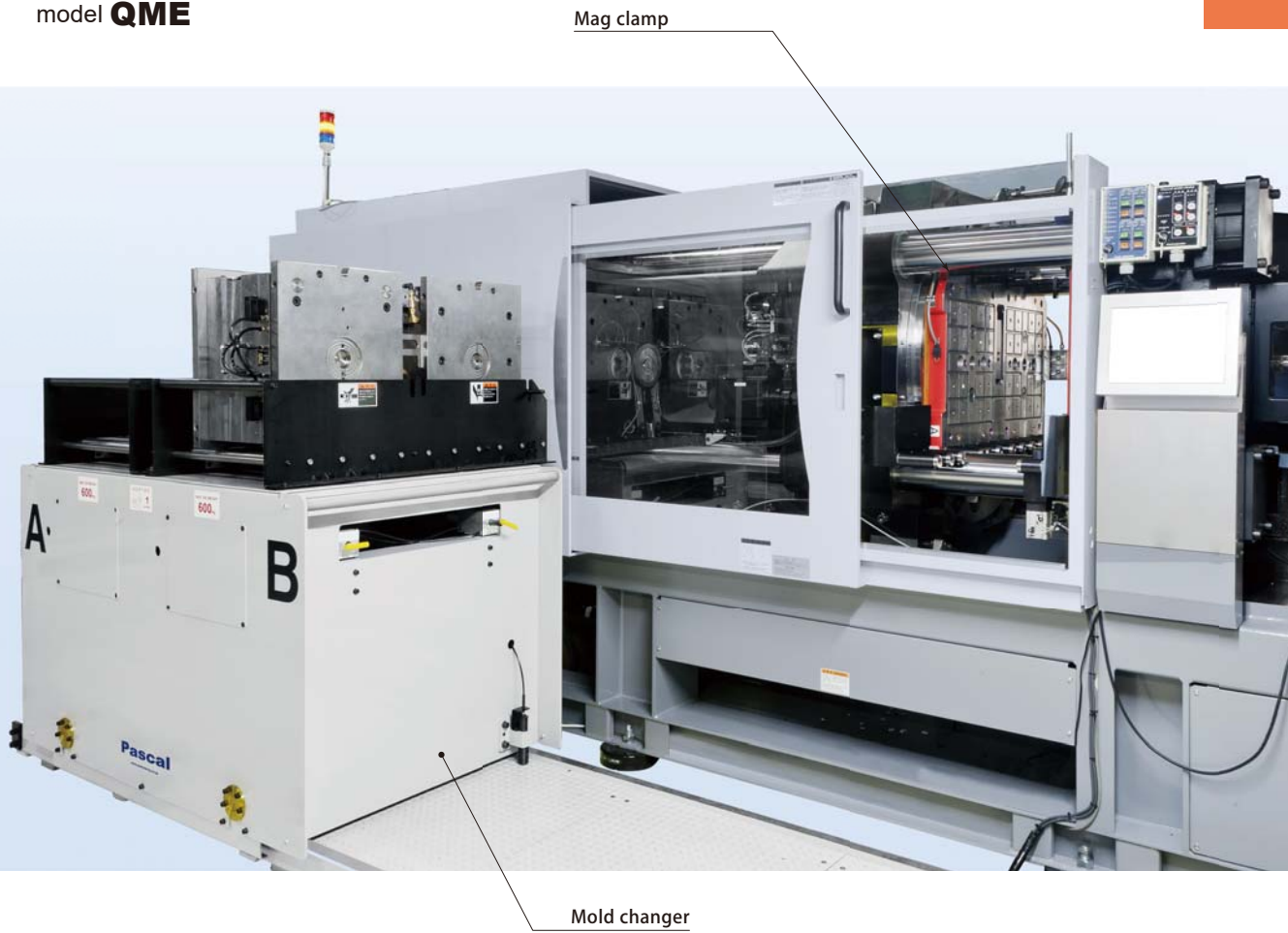

Changer travel		Manual, On the rail
Mold loading		Manual loading
Clamping force of IMM		2500 kN (250 tonf)
Max. mold weight		600 kg × 2 molds
Max. mold size	mm	depth : 400 × height : 500 × width : 500
Changer traveling distance	m	4.3

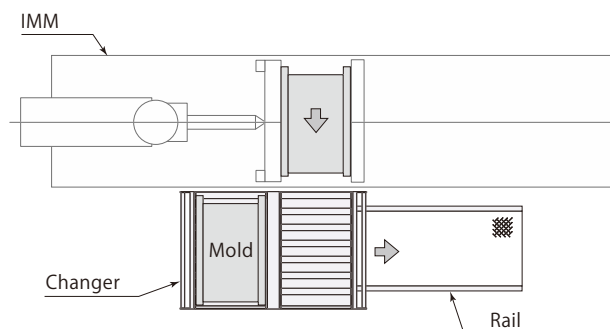

1,750kN IMM Mold 600 kg × 2 molds

Mag clamp

model **QME**

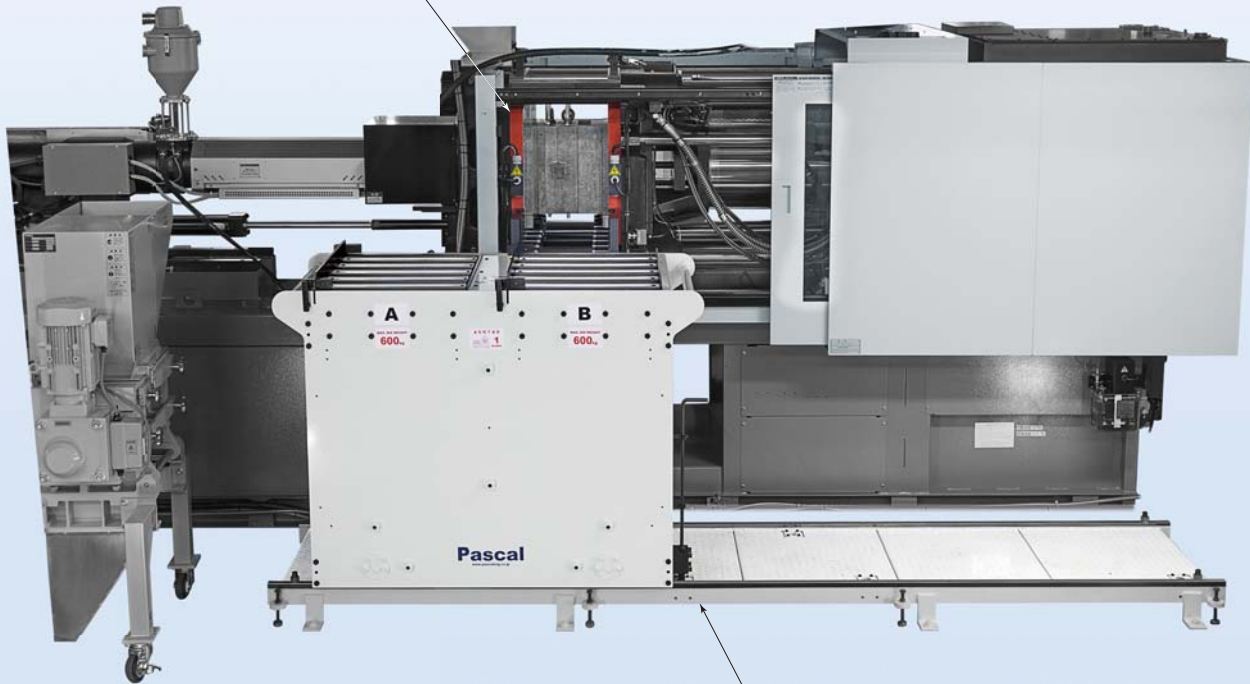

Mold changer

Changer travel		Manual, On the rail
Mold loading		Manual loading
Clamping force of IMM		1750 kN (175 tonf)
Max. mold weight		600 kg × 2 molds
Max. mold size	mm	depth : 500 × height : 480 × width : 500
Changer traveling distance	m	0.65 (Max. 1.75)

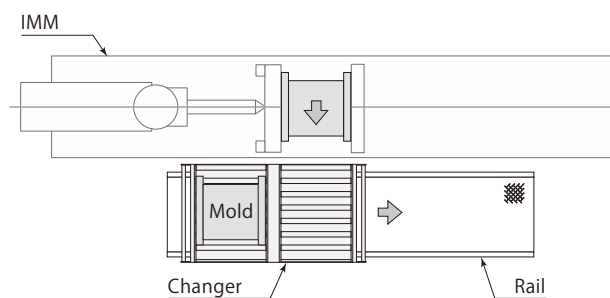

1,600kN IMM Mold 25 ton × 1 mold



Die stage	
Mold loading	Pin gear type
Clamping force of IMM	1600 kN (160 tonf)
Max. mold weight	25 ton × 1 mold
Max. mold size	mm depth : 2800 × height : 1560 × width : 1500

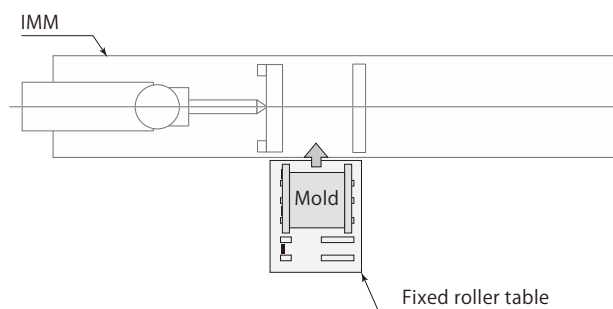

500kN IMM Mold 800 kg × 2 molds



Changer travel		Manual, Non track
Mold loading		Manual loading
Clamping force of IMM		1500 kN (150 tonf)
Max. mold weight		800 kg × 2 molds
Max. mold size	mm	depth : 500 × width : 520
Changer traveling distance	m	0.63

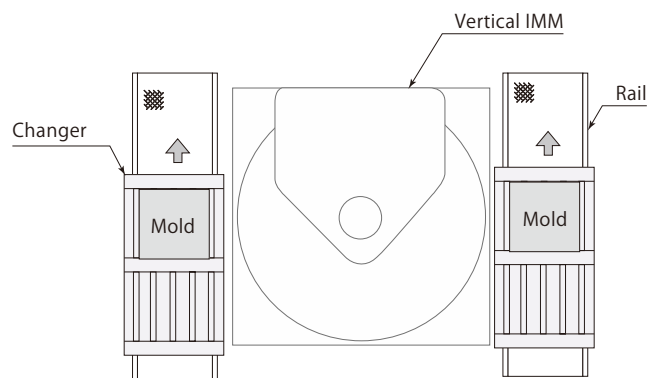

1,500kN IMM Mold 700 kg × 2 molds

Mag clamp model **QME**

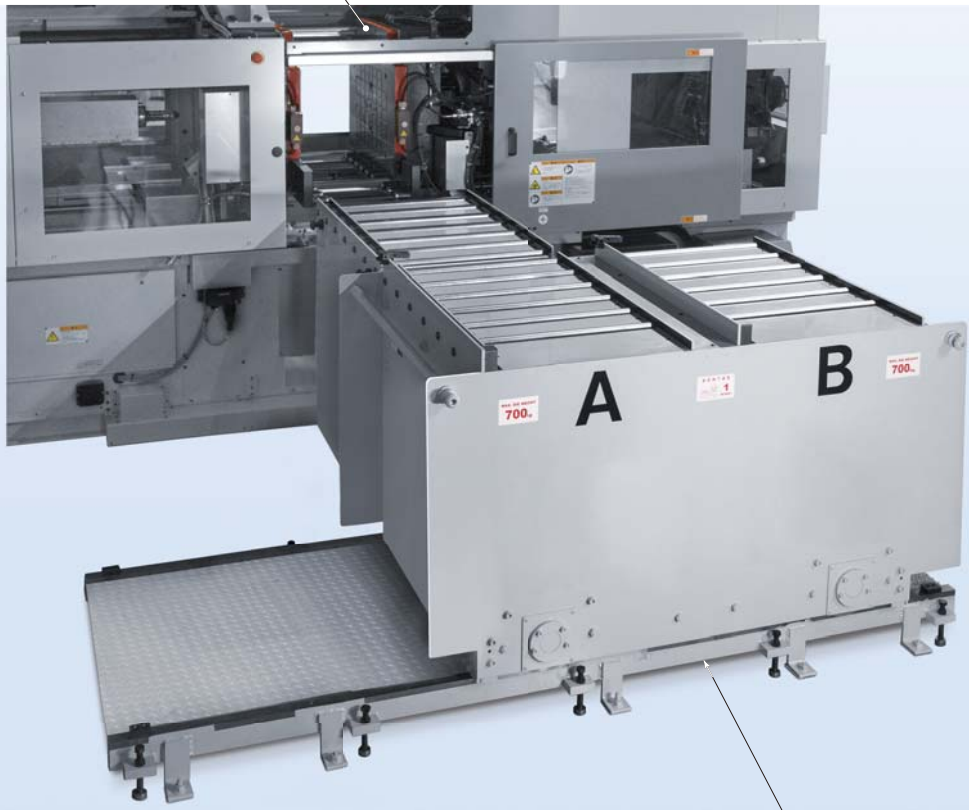

Mold changer

Changer travel		Manual, On the rail
Mold loading		Manual loading
Clamping force of IMM		1500 kN (150 tonf)
Max. mold weight		700 kg × 2 molds
Max. mold size	mm	depth : 575 × height : 500 × width : 800
Changer traveling distance	m	0.75

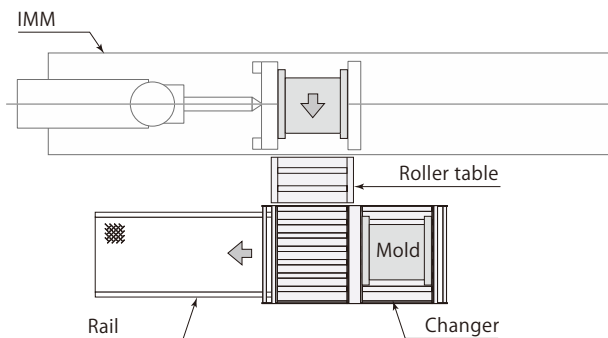

1,000kN IMM Mold 600 kg × 2 molds

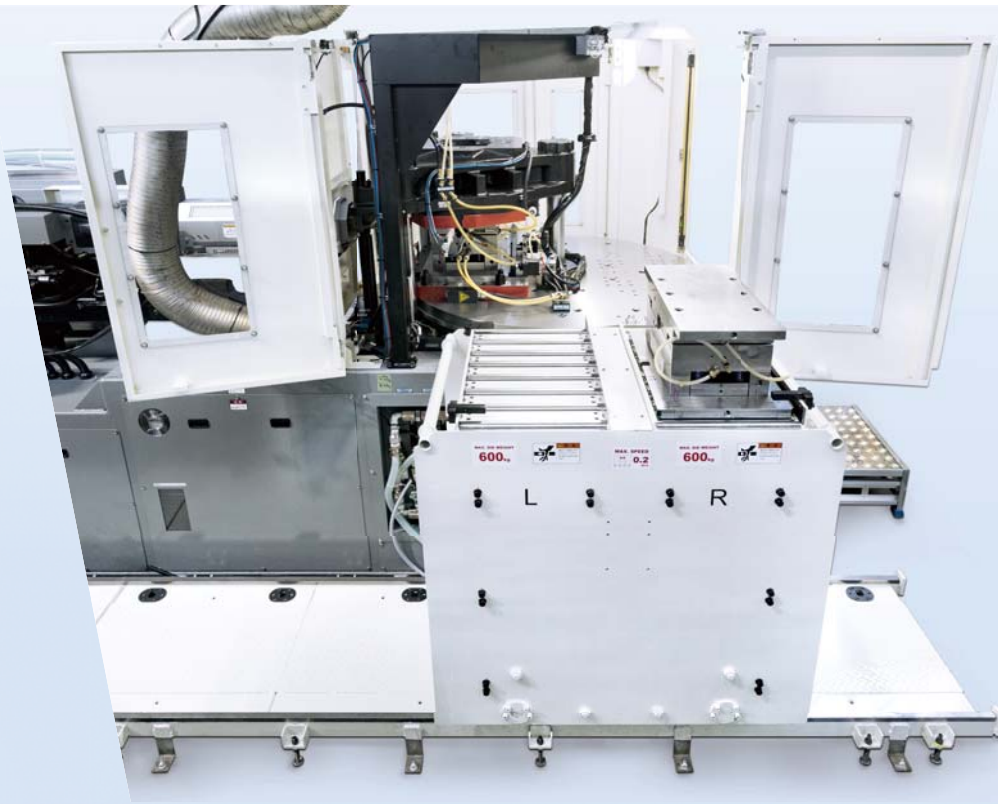

Changer travel		Manual, On the rail
Mold loading		Manual loading
Clamping force of IMM		1000 kN (100 tonf)
Max. mold weight		600 kg × 2 molds
Max. mold size	mm	depth : 280~550 × width : 360
Changer traveling distance	m	0.5

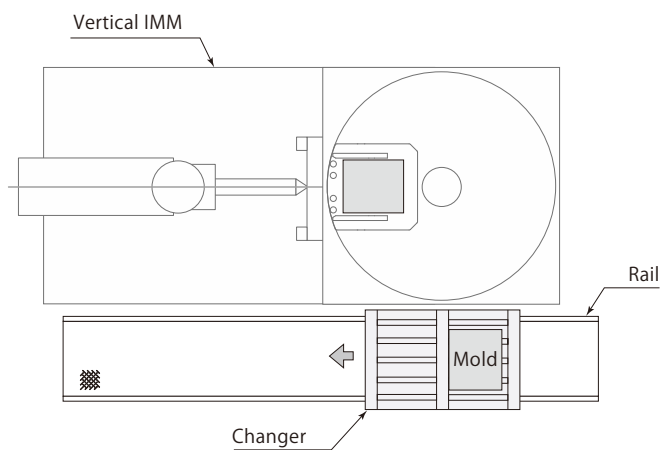

1,000kN IMM Mold 600 kg × 1 mold

model **QMA**



Changer travel		Manual, Non track
Mold loading		Manual loading
Table		Elevation type
Clamping force of IMM		1000 kN (100 tonf)
Max. mold weight		600 kg × 1 mold
Max. mold size	mm	depth : 400 × height : 400 × width : 400

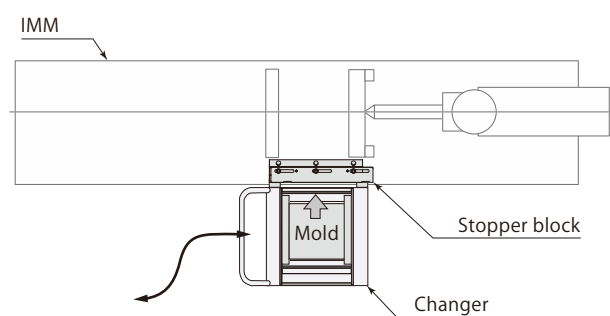

500kN IMM Mold 300 kg × 2 molds

Air clamp model **QME**



Changer travel		Manual, On the rail
Mold loading		Manual loading
Clamping force of IMM		500 kN (50 tonf)
Max. mold weight		300 kg × 2 molds
Max. mold size	mm	depth : 350 × height : 350 × width : 350
Changer traveling distance	m	0.55 (Max. 1.1)

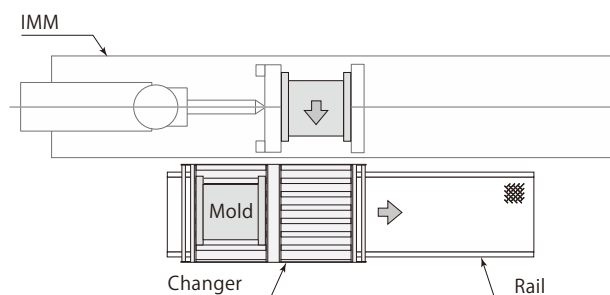

500kN IMM Mold 300 kg × 1 mold

model **QMA**



Changer travel		Manual, Non track
Mold loading		Manual loading
Table		Elevation type
Clamping force of IMM		500 kN (50 tonf)
Max. mold weight		300 kg × 1 mold
Max. mold size	mm	depth : 340 × height : 340 × width : 280

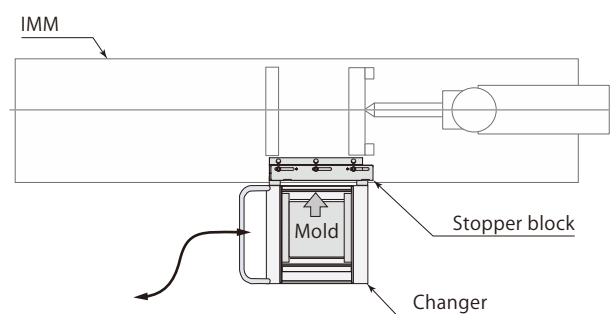

490kN IMM Mold 600 kg × 1 mold

model **QMA**



Changer travel		Manual, Non track
Mold loading		Manual loading
Table		Elevation type
Clamping force of IMM		490 kN (49 tonf)
Max. mold weight		600 kg × 1 mold
Max. mold size	mm	depth : 300 × height : 270 × width : 255

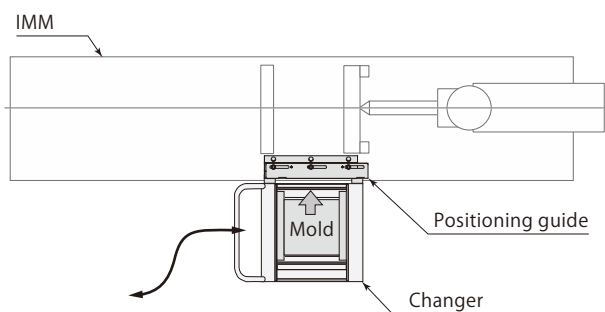

Clamping force of IMM		30000 kN (3000 tonf)
Max. mold weight	kg	30000
Number of mold		2
Changer traveling		Powered / On the rail
Mold loading		Drive rollers type

● Technical specifications differ on each order. Contact Pascal for the details.

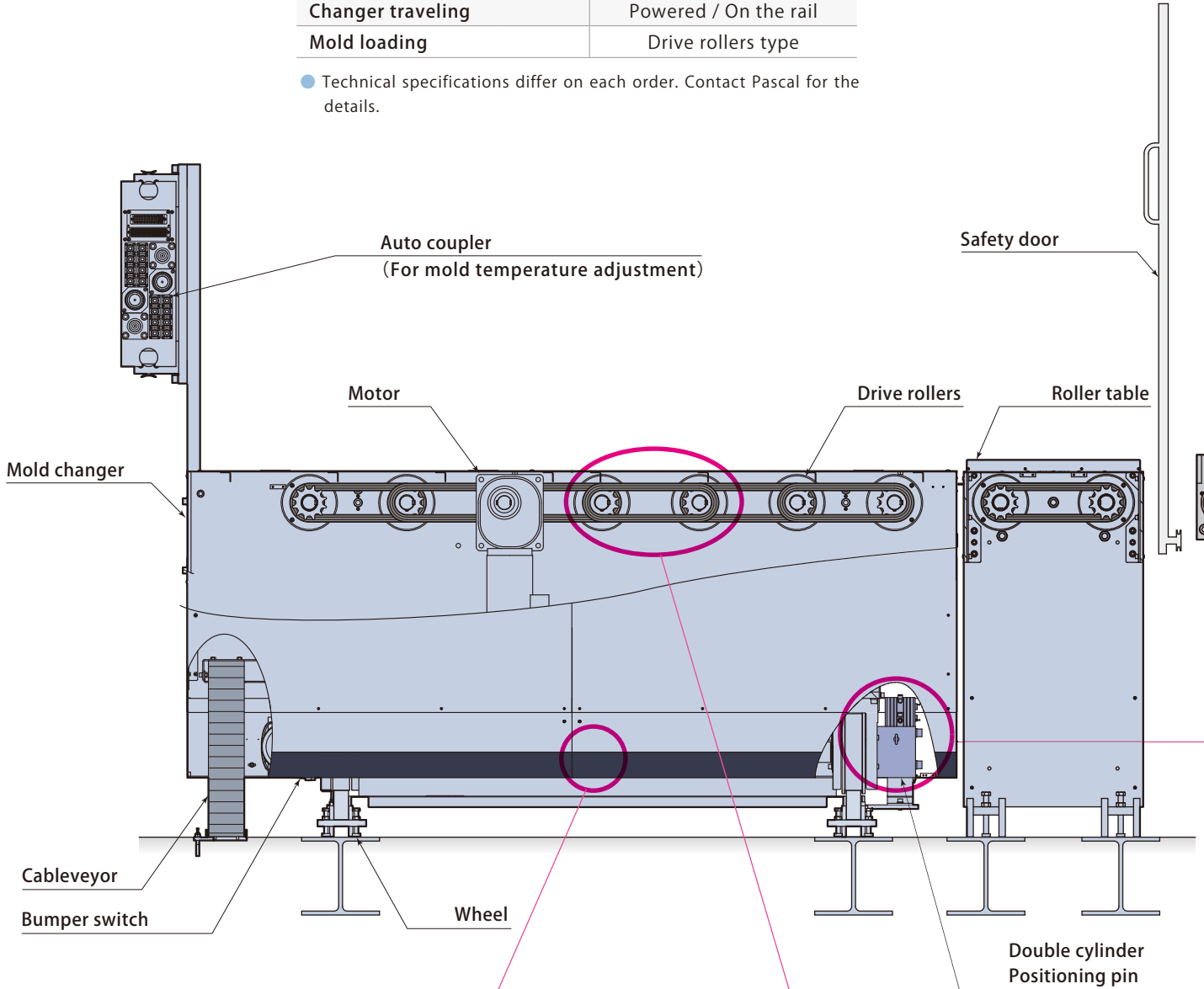

Bumper switch with function of cushion
It is a safety switch which alleviates the shock or impact when the bumper makes contact.



Highly rigid rollers
The rollers are cut out from a block of material and have excellence for high rigidity and durability.

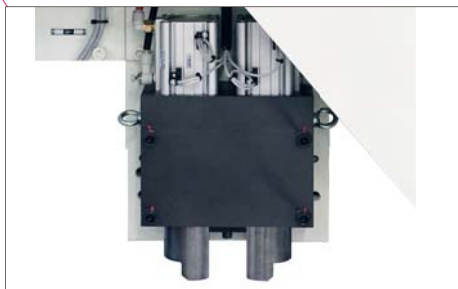
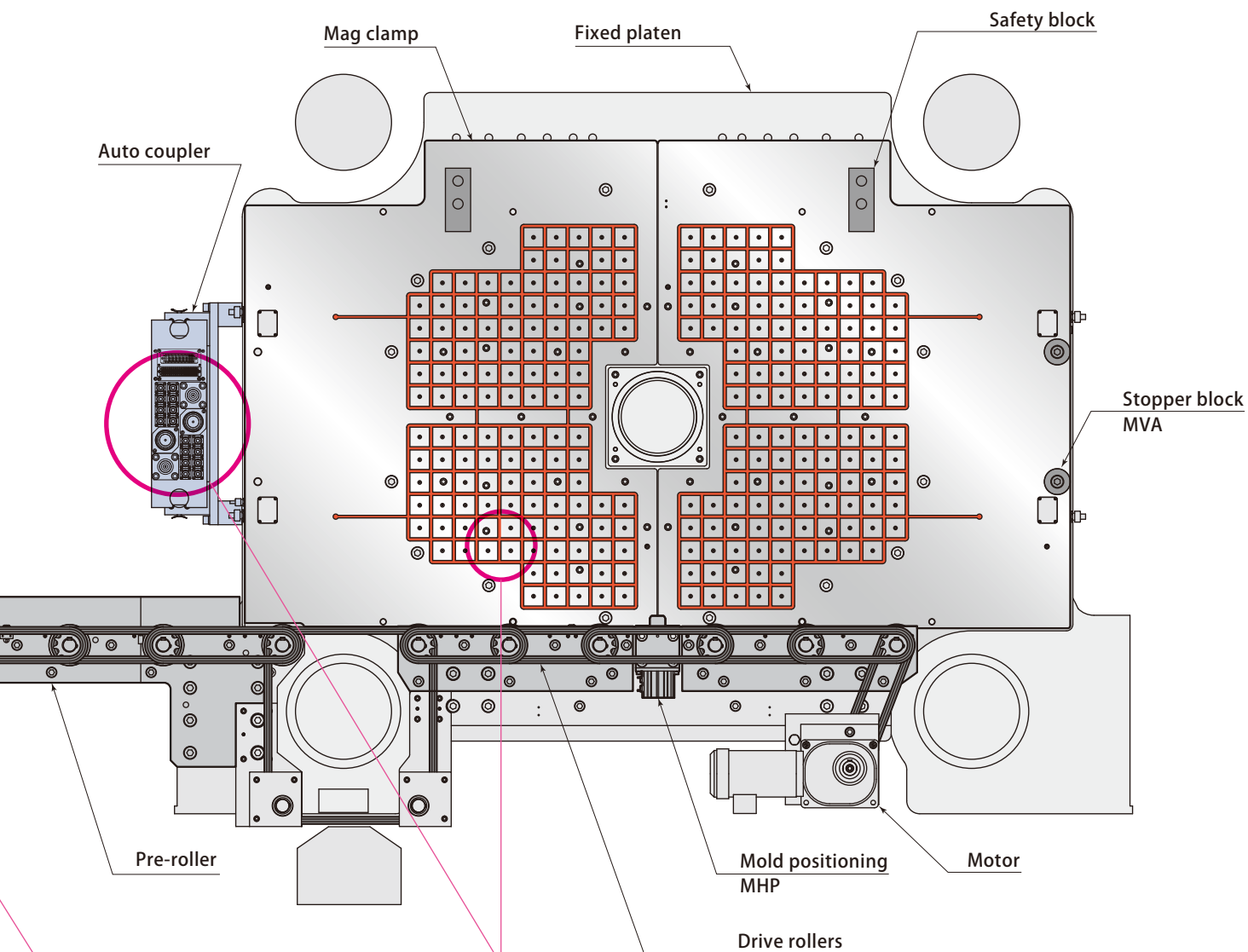

Double cylinder Positioning pin

Mold changer is positioned by the double cylinder positioning pin. 2 pins pinch the block rigidly and the changer can be positioned accurately.

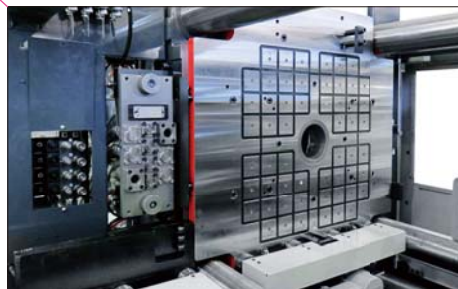

Mag clamp & Auto coupler

Introduction of mold changer, mag clamp and auto coupler makes the total automation of the mold change operation realized.

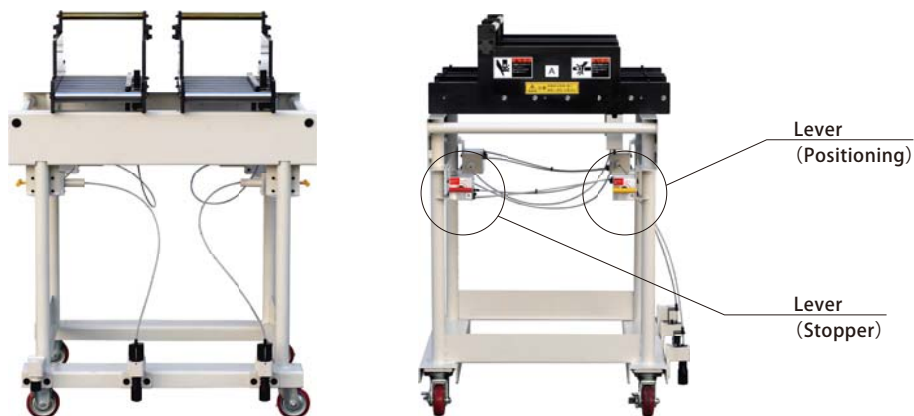

- Safety Interlock : While the mold is traveling(the positioning pin of mold changer is unlocked), the mold fall protection pin can not be released. While the mold is loaded/unloaded(the mold fall protection pin is unlocked), the positioning pin of mold changer can not be released.

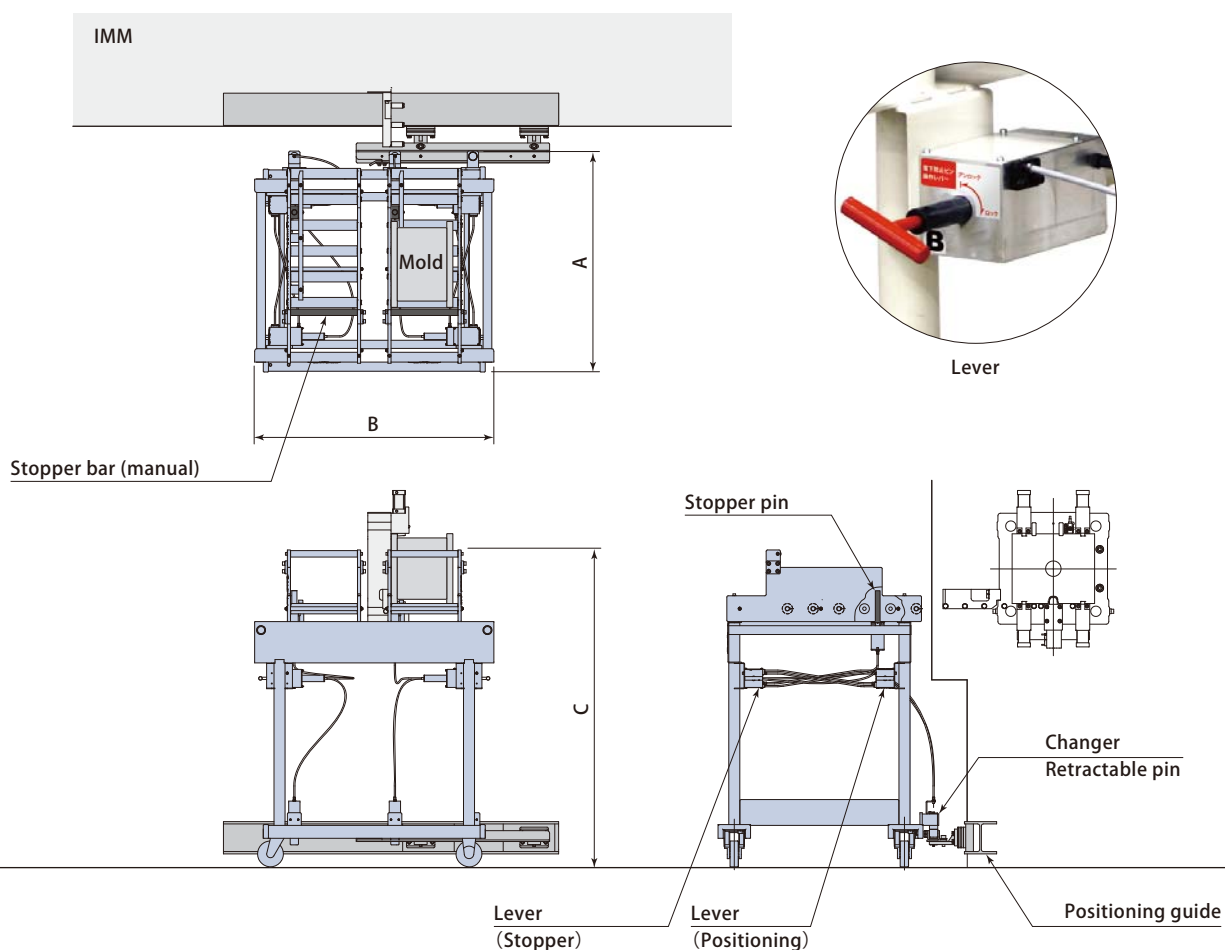

Model		QMF1	QMF2
Clamping force of IMM		400 ~ 1000 kN (40 ~ 100 tonf)	400 ~ 600 kN (40 ~ 60 tonf)
Max. mold weight	kg	600	300
Number of load		1 mold	2 molds
A	mm	525.5	594
B	mm	636.5	1065
C	mm	1131	1069

- The table is not elevated.
- For the positioning method of mold changer, there are stopper type and pin type. Refer to the **page →45** for the details.
- The dimension C varies according to the machine level. Contact Pascal for the details.

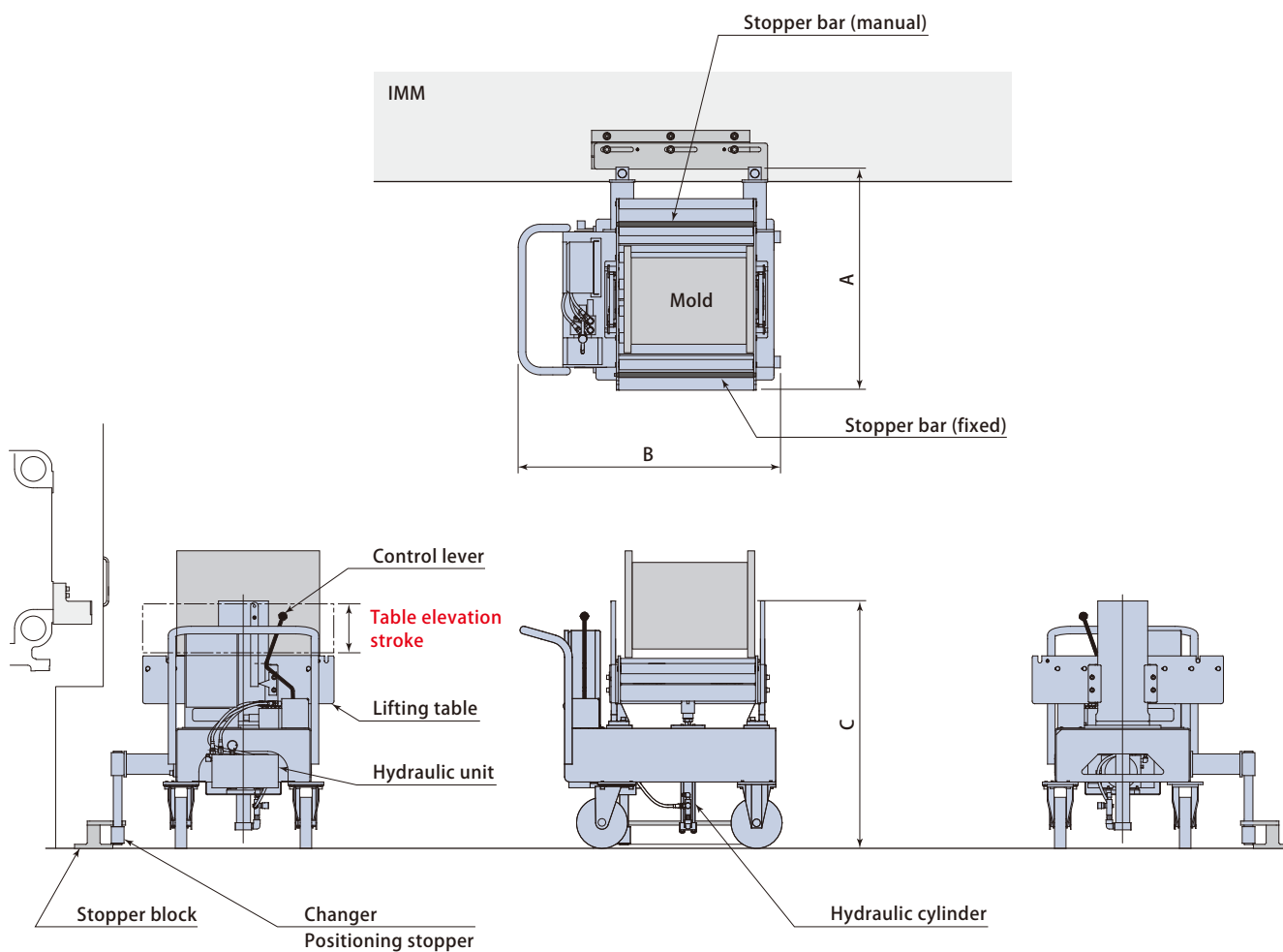

Model	QMA1	
Clamping force of IMM	400 ~ 1000 kN (40 ~ 100 tonf)	
Max. mold weight	kg	600
Number of load	1 mold	
A	mm	765
B	mm	1250
C	mm	1190
Max. table lifting stroke	mm	350

● For the positioning method of mold changer, there are stopper type and pin type. Refer to the **page →45** for the details.



Table lift up

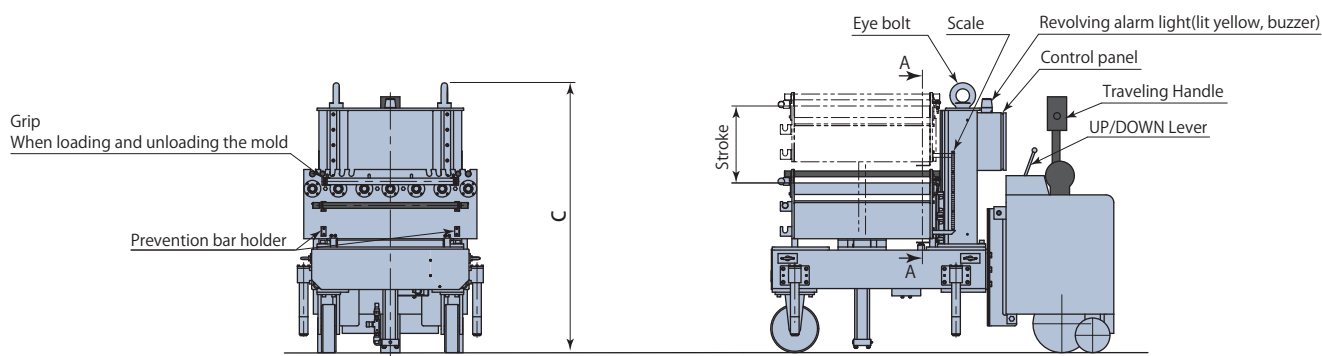
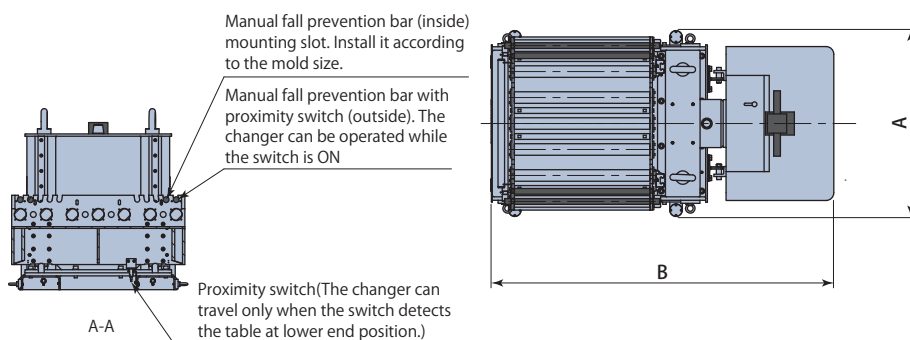
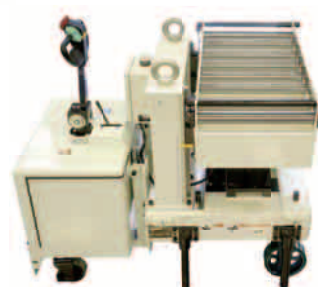

Model	QMB1		
Clamping force of IMM	400 ~ 4500 kN (40 ~ 450 tonf)		
Max. mold weight	kg	1500	2500
Number of load	1 mold		
A	mm	938	1120
B	mm	1755	2164
C	mm	1330	1400
Max. table lifting stroke	mm	400	250

● For the positioning method of mold changer, there are stopper type and pin type. Refer to the **page →45** for the details.



Table lift up

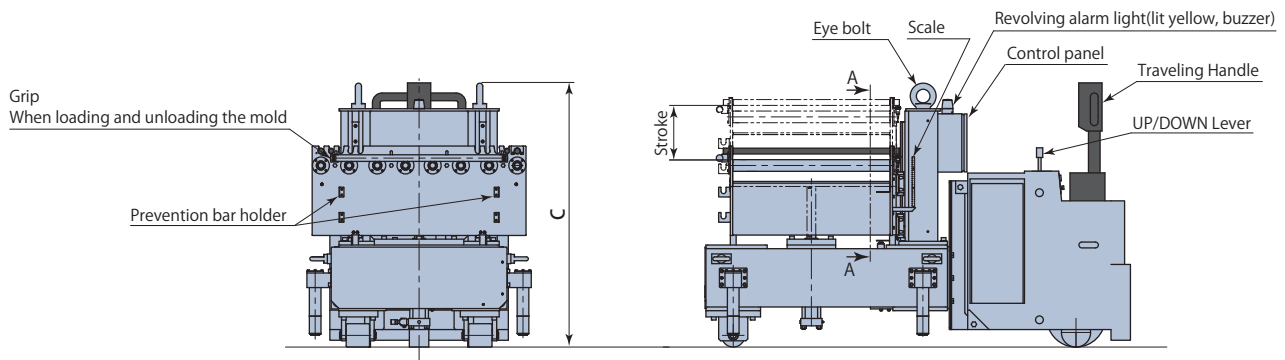
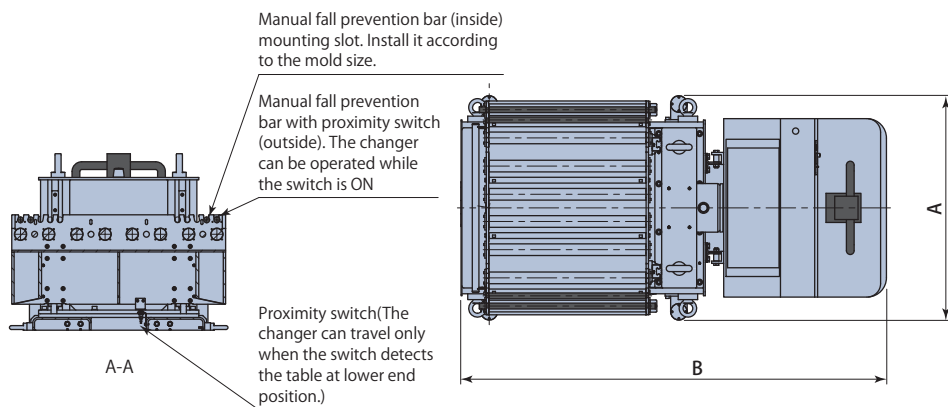
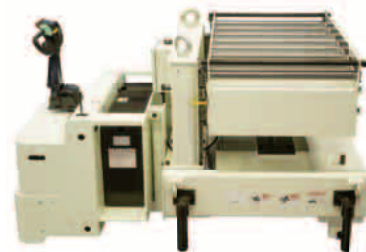

Model	QMB1-2500	
Clamping force of IMM	400 ~ 4500 kN (40 ~ 450 tonf)	
Max. mold weight	kg	2500
Number of load	1 mold	
A	mm	1153
B	mm	2188
C	mm	1400
Max. table lifting stroke	mm	250

● For the positioning method of mold changer, there are stopper type and pin type. Refer to the **page →45** for the details.

Stopper type

- The changer is positioned by means of the fixed pin (stopper) and the key plate as shown in the sketch below.

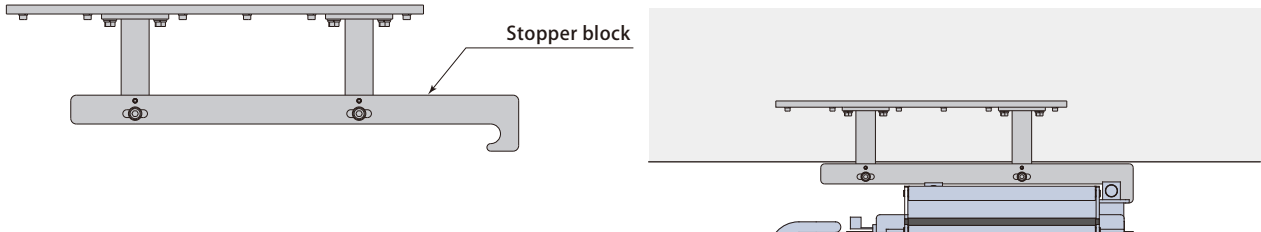

Mount details

On the wall of the machine

On the floor (to be anchored)

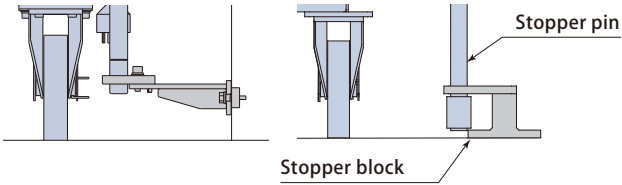

Positioning pin type

- The changer is positioned by a retractable dowel pin

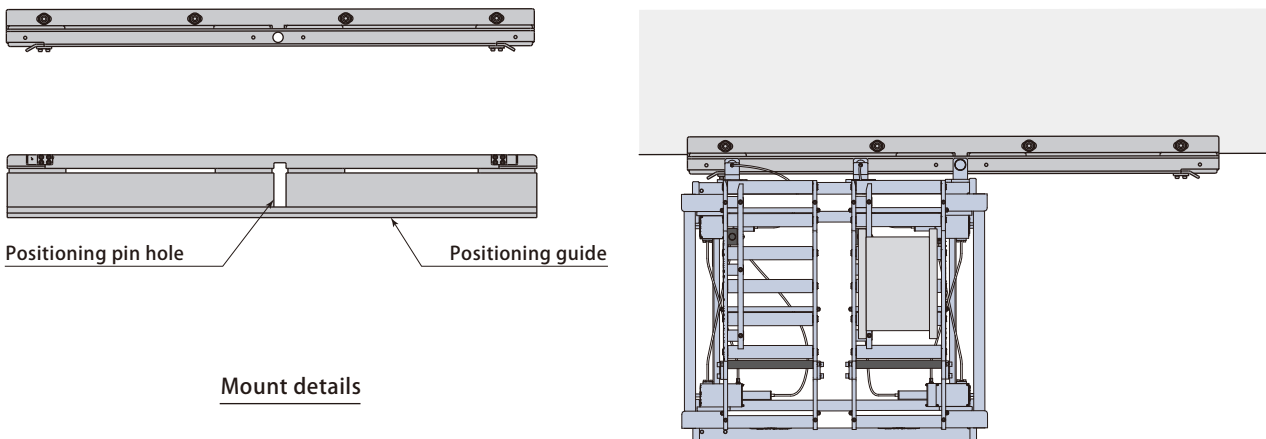

Mount details

On the wall of the machine

On the floor (to be anchored)

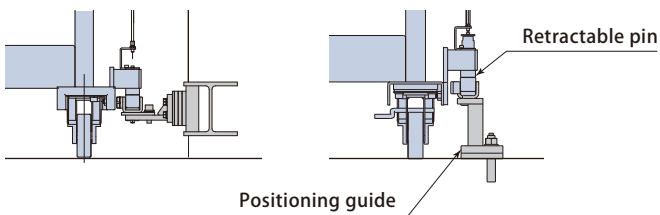

Level Scale

- Adjust the roller level checking visually with the scale on the changer.

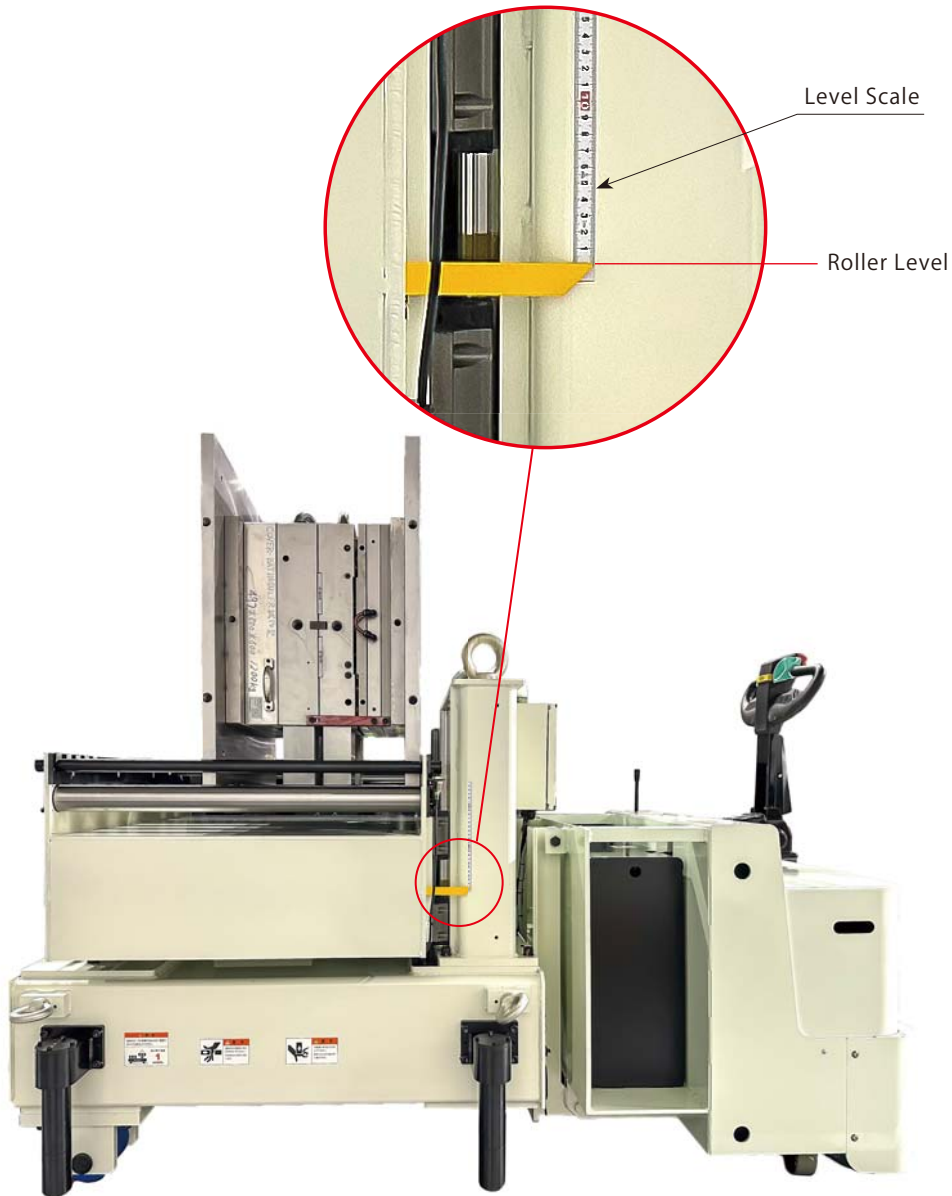

<p>Roller Level</p> <p style="text-align: right; margin-right: 20px;">mm</p> <hr style="width: 80%; margin: 0 auto;"/> <p style="text-align: center;">Pascal</p>
--

Write the level in the label when mold changing and stick it at a readily visible place.

Label sticker (included) Size: 70 x 140

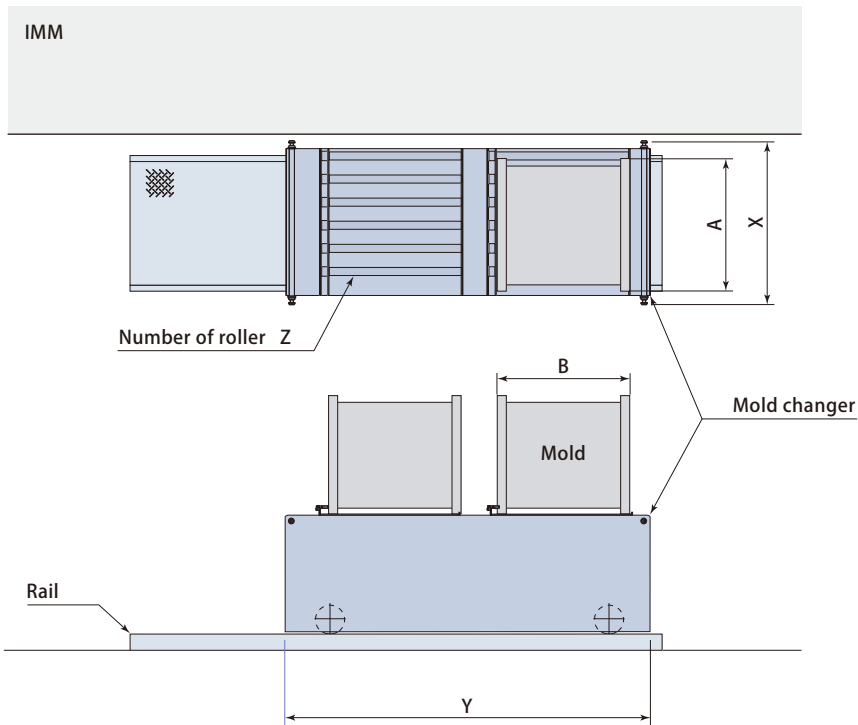

Model			QME						
Clamping force of IMM			500 kN (50 tonf)	800 kN (80 tonf)	1000 kN (100 tonf)	1300 kN (130 tonf)	1500 kN (150 tonf)	2000 kN (200 tonf)	2500 kN (250 tonf)
Max. mold weight	kg		300	400	400	600	800	1000	2000
Number of load			2 molds						
Mold width	A	mm	400	400	400	600	600	800	800
Mold thickness	B	mm	400	400	400	500	500	650	650
Mold changer width	X	mm	500	500	500	700	700	900	900
Mold changer length	Y	mm	1250	1250	1250	1450	1450	1750	1750
Number of rollers	Z		4	4	4	5	5	6	6

Manual loading

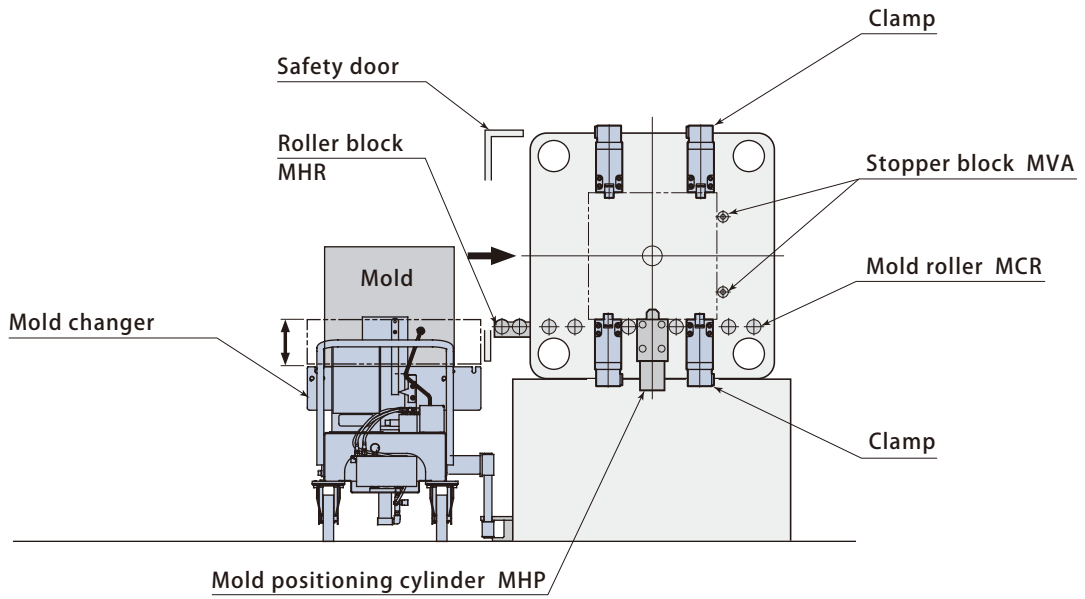

Pusher type

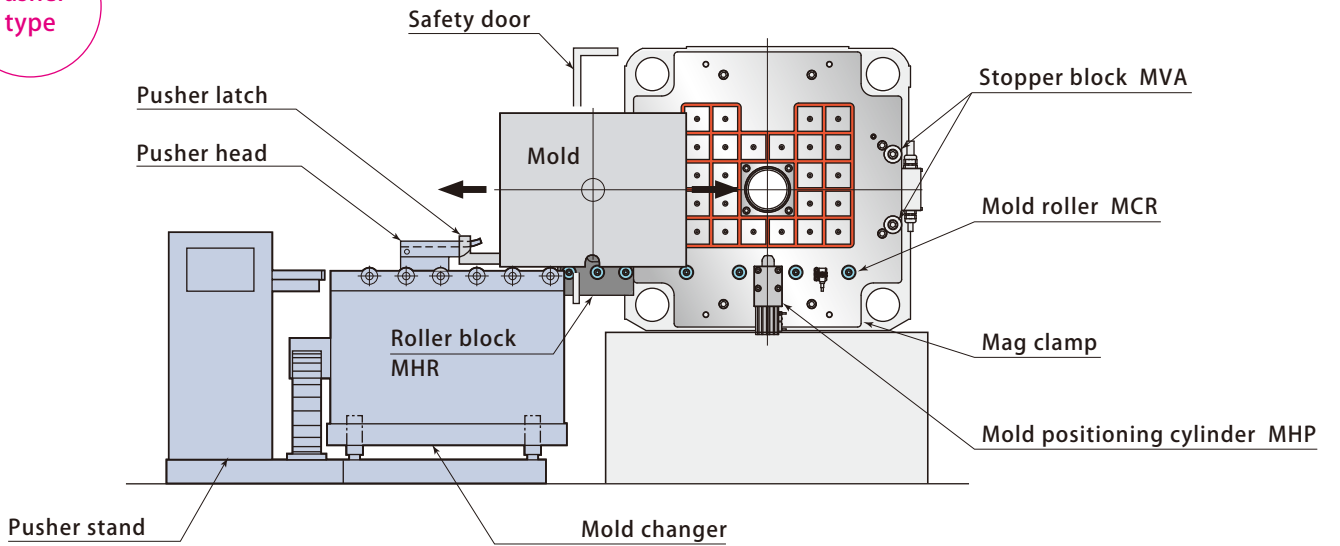

* For the installation of pusher, there are stand type (installed separately) and incorporated type in Mold changer.

Drive roller type

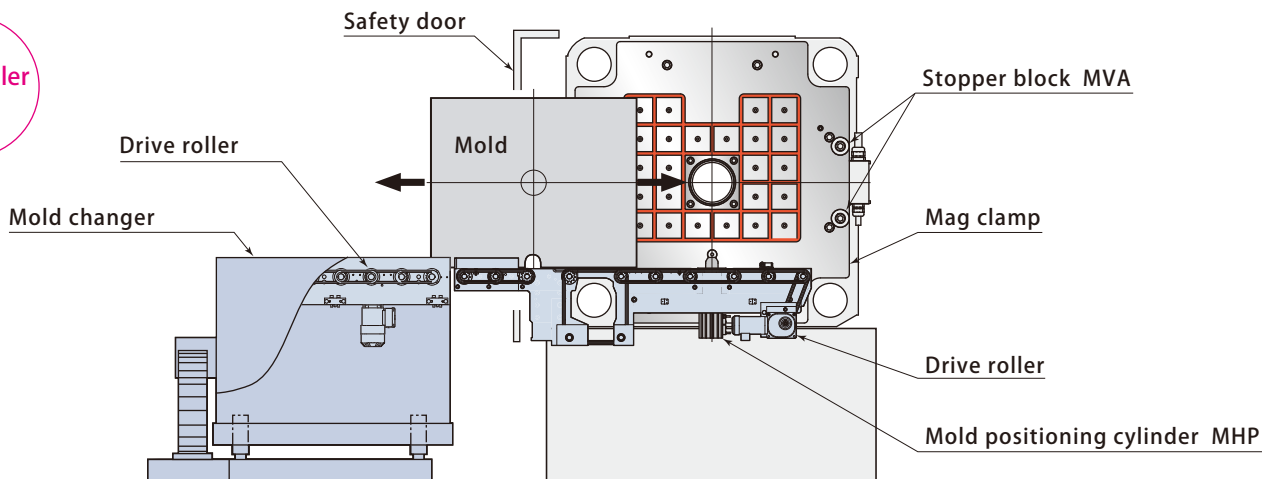

Difference between drive roller type and Pusher type

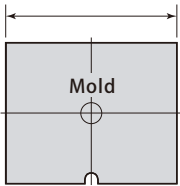
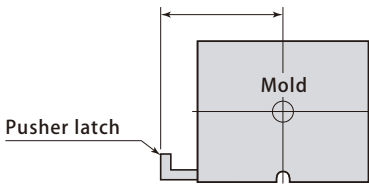
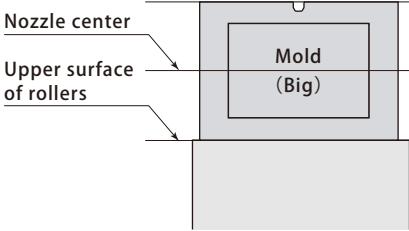
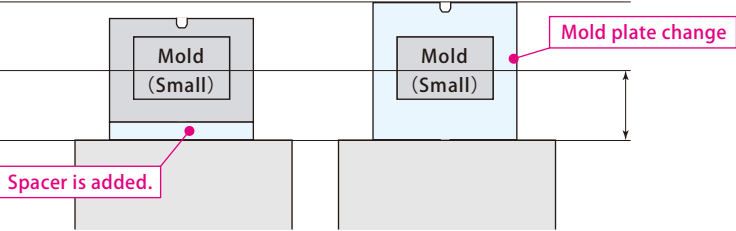
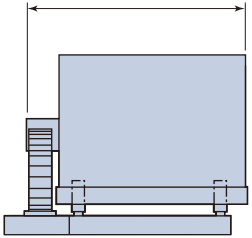
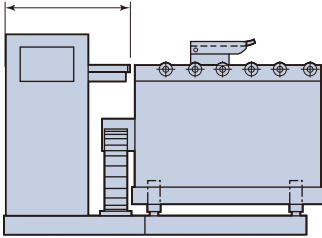
Type	Drive roller type	Pusher type	
Addition of hook	—	Add the pusher latch to the mold	
Mold width	<p>No need to unify</p> 	<p>Need to unify</p> 	
Mold height	<p>Unify the distance (loading level) from the roller top to the nozzle center.</p>		
		<p>In case of the Mag clamp</p> 	<p>In case of the hydraulic / air clamp</p> 
Mold changer size	<p>Takes up minimum space</p> 	<p>Needs extra space for a push / pull device</p> 	



Mold changer Layout example

Manual Non track

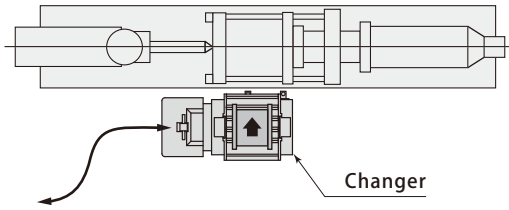

Manual On the rail

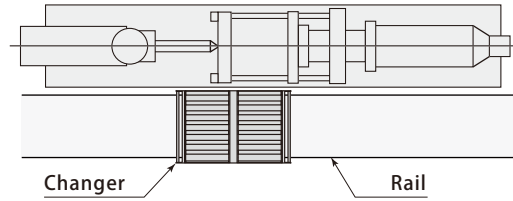

Pusher 1 pitch traveling with roller table 2 molds

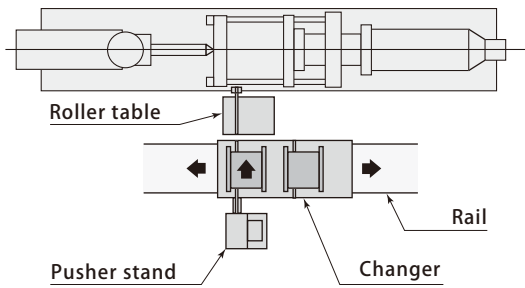

Pusher Short distance traveling 2 molds

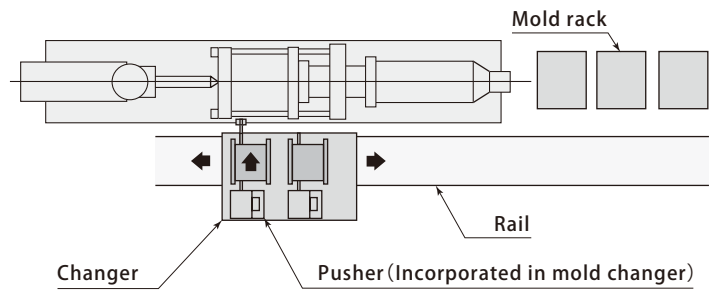

Drive rollers 1 pitch traveling (with standby position) 2 molds

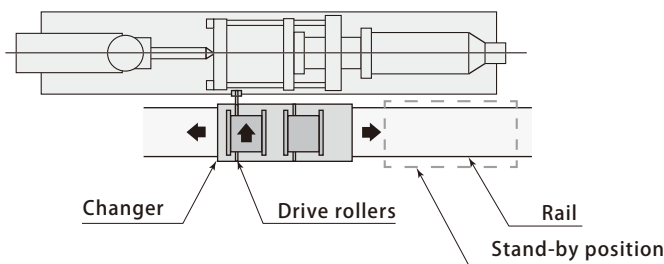

Drive rollers Fixed roller table, 1 molds Pushing in / out style

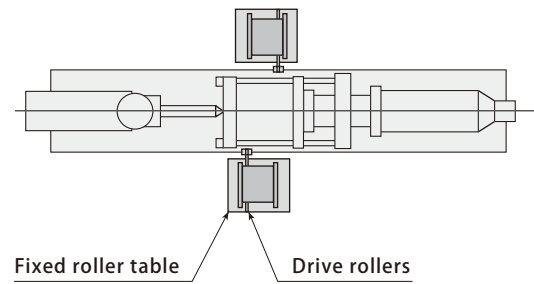

Drive rollers 1 pitch traveling, 2 molds Pushing in / out style

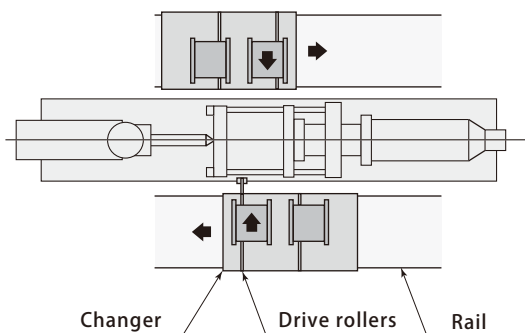

Drive rollers Long distance traveling 2 molds, Face to face

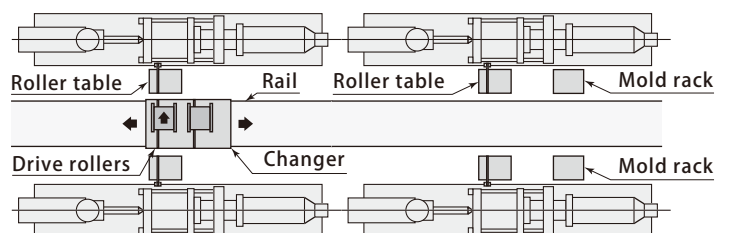

Pascal

corporation

Itami, Hyogo, Japan 664-8502
TEL. +81-72-777-3333 FAX. +81-72-777-3520

Chicago, U.S.A.	TEL. +1-847-427-1234
Stuttgart, Germany	TEL. +49-711-782-850-0
Dalian, China	TEL. +86-411-8732-2988
Shanghai, China	TEL. +86-21-5263-4122
Changwon, Korea	TEL. +82-55-274-0971
Bangkok, Thailand	TEL. +66-2173-5855

