

Pascal die casting machine system

C-plate mag clamp

die clamping system

pascal pump

hydraulic control unit

auto coupling system

mag clamp for press machine

quick die change system

link clamp & swing clamp

expansion clamp

Pal-fix

pallet clamp

robot tool changer

die handling system

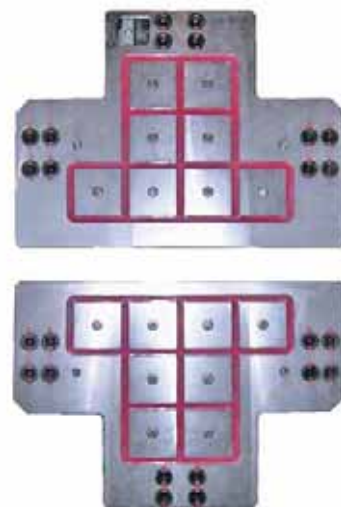

c-plate mag clamp

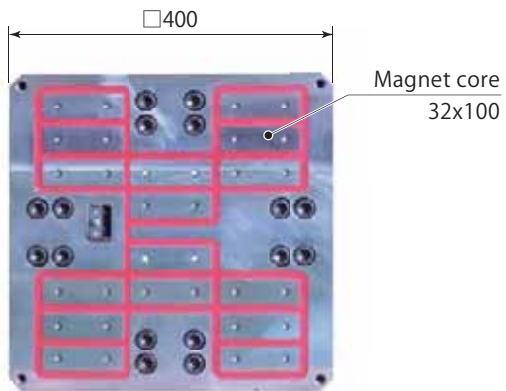
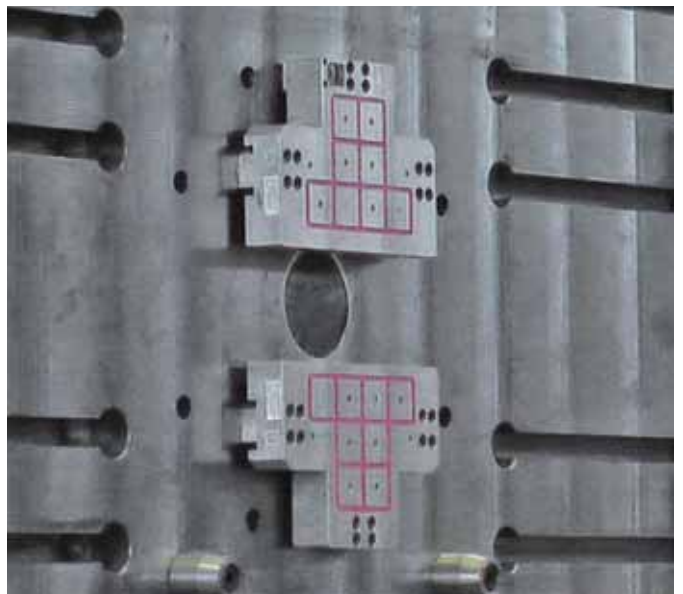

Max. clamping force : 55 kN

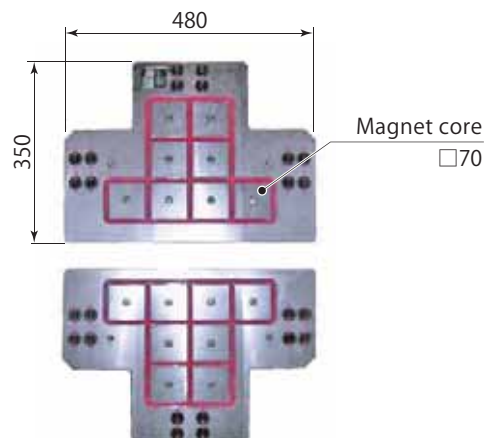

Max. clamping force : 117.6 kN (58.8 kNx2)

Magnetic clamp for die casting machine

When the ejector plate draws back and ejector pin is fixed, a large load might cause damage to the die. However, the C-plate mag clamp can **prevent the die from such damage** by detaching from the plate if force exceeding clamp force is exerted while the plate is drawing back.

When ejector plate refracts back : Separation from ejector plate (A, B-plate)

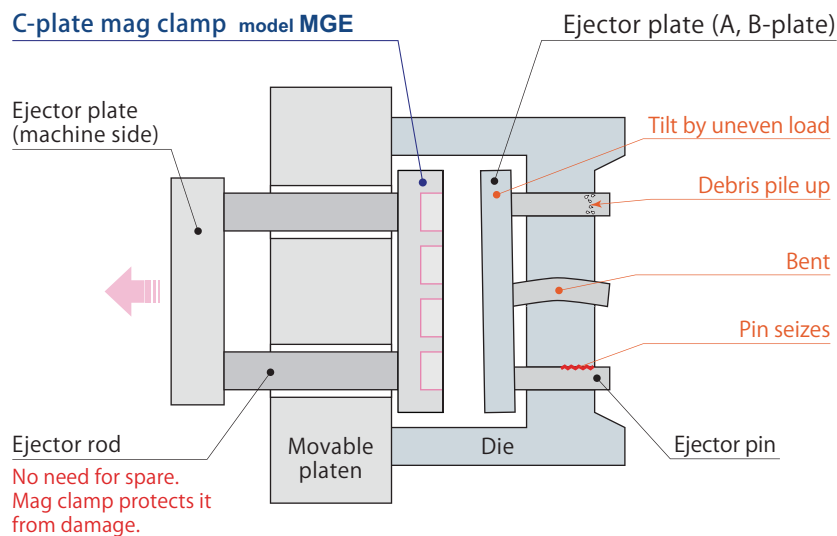

When castings are ejected

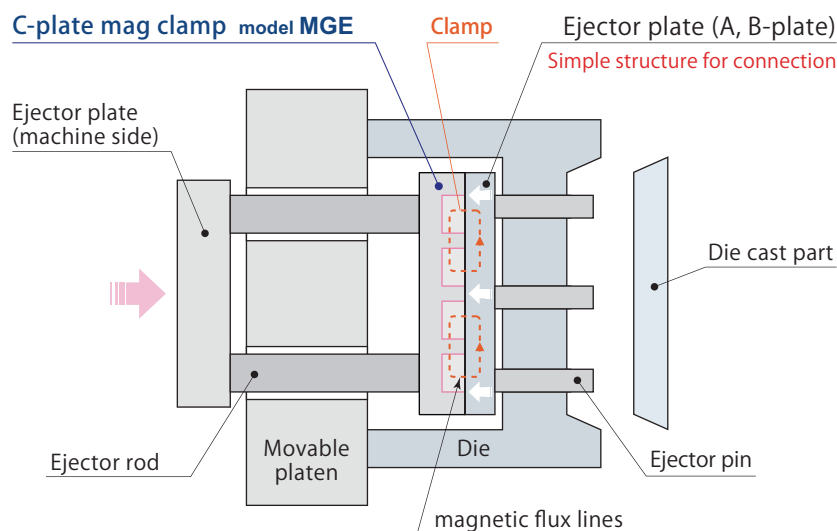

- Clamp ejector plate instantly with super strong permanent magnet.
- No electricity consumed during clamped condition. **Clean & Ecology**

die-clamping system

Installation on 2250 tonf die-casting machine

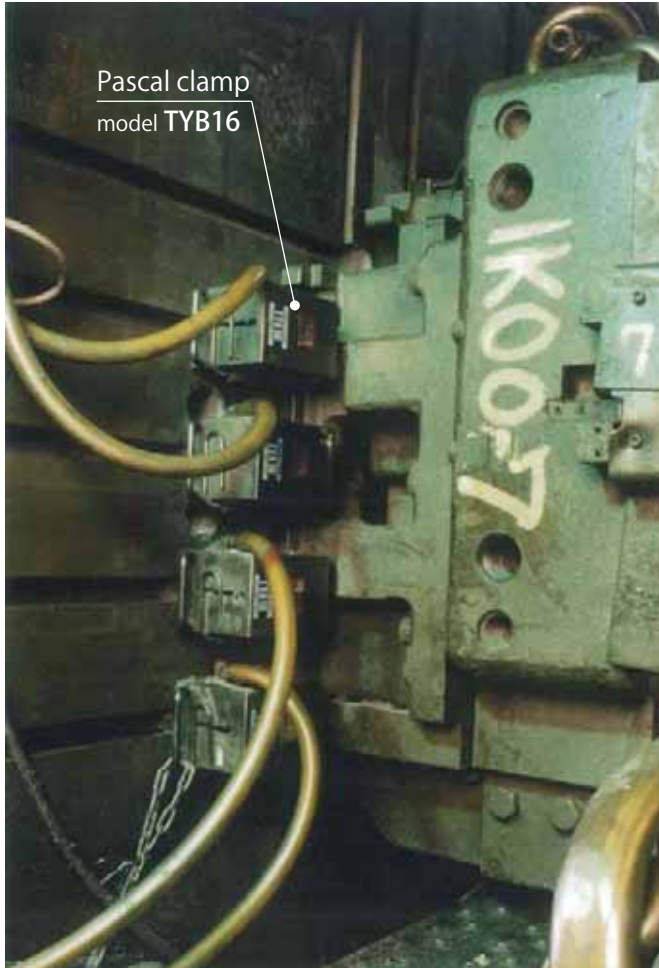

Installation on 350 tonf die-casting machine

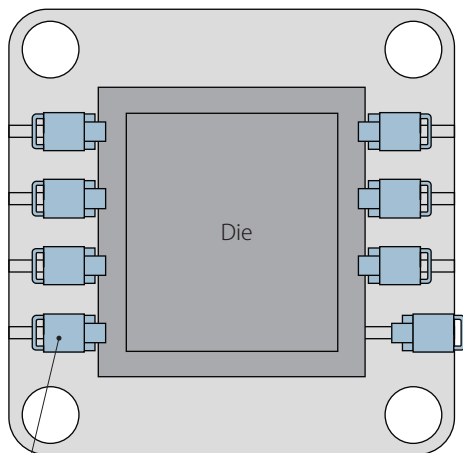
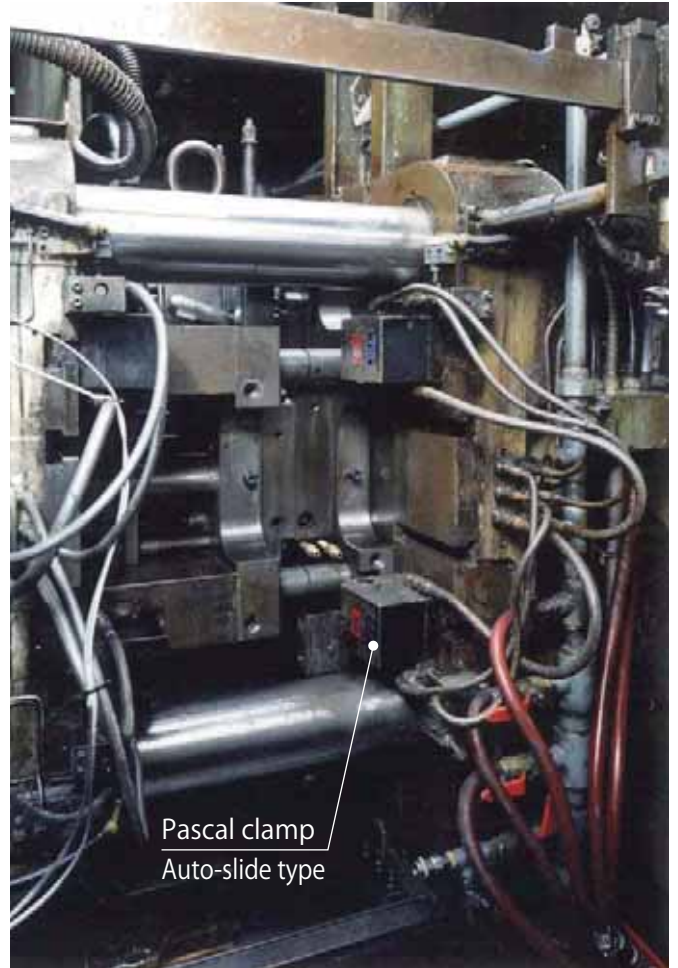

Pascal clamp model TYB16

Clamping force : $156 \text{ kN} \times 8 = 1248 \text{ kN}$

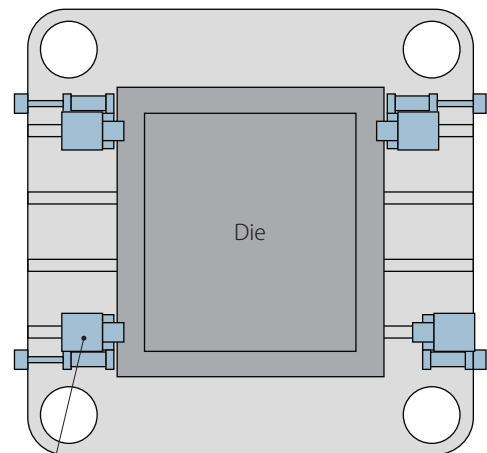

Pascal clamp (Auto-slide type)

Clamping force : $61.7 \text{ kN} \times 4 = 246.8 \text{ kN}$

**Assures high durability and reliability even under severe operating condition
(Heat, vapor, splash of release agent, etc.).**

- Perfect protection against dust or die release agents
- Best solution for heat and corrosion
- Clamp force 4, 6, 10, 16 tonf
25 tonf type now developing



Pascal clamp model TYB

■ Grease Nipple

For lubrication for clamp lever and shaft (Option)

■ Dust seal

Fluorocarbon (VITON)

■ Long stroke

Can accommodate big tolerance of clamping height and T-slot dimensions
Stroke : 10~12 mm

■ Lever shaft

Ion-Nitriding

■ Dust cover

Protect from vapor, release agent's splash and foreign materials.

■ Dust seal

Fluorocarbon (VITON)

■ Ram-cylinder

Ion-Nitriding
Non-breathing ram cylinder is adopted. It can protect the intrusion of dusts or release agents.

■ Piston

Hard-Chromed

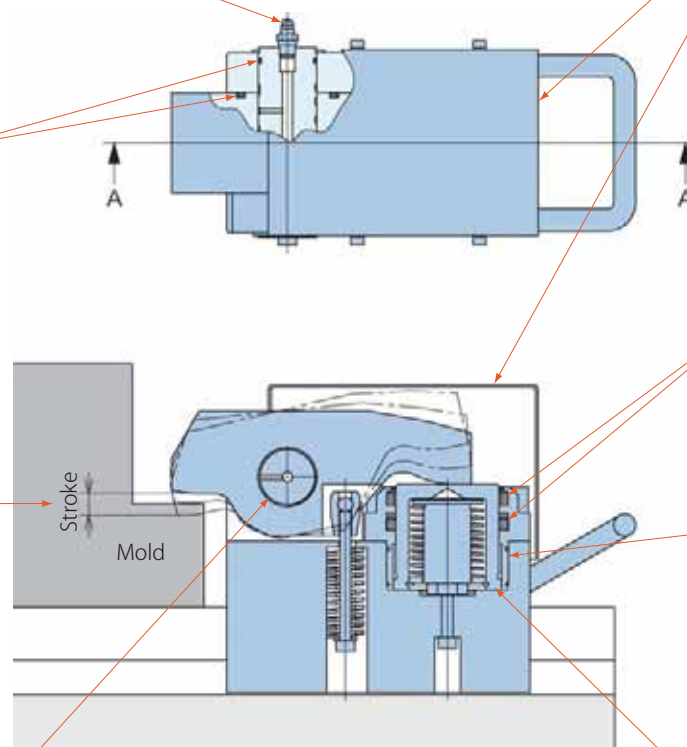

Section A - A

pascal pump

Compact, high performance air-driven hydraulic pump



hydraulic control unit

High performance hydraulic control unit with digital pressure gauge.



auto coupling system

Installation on 2500 tonf Injection molding machine



Pascal clamp model TKB40



Stationary platen side

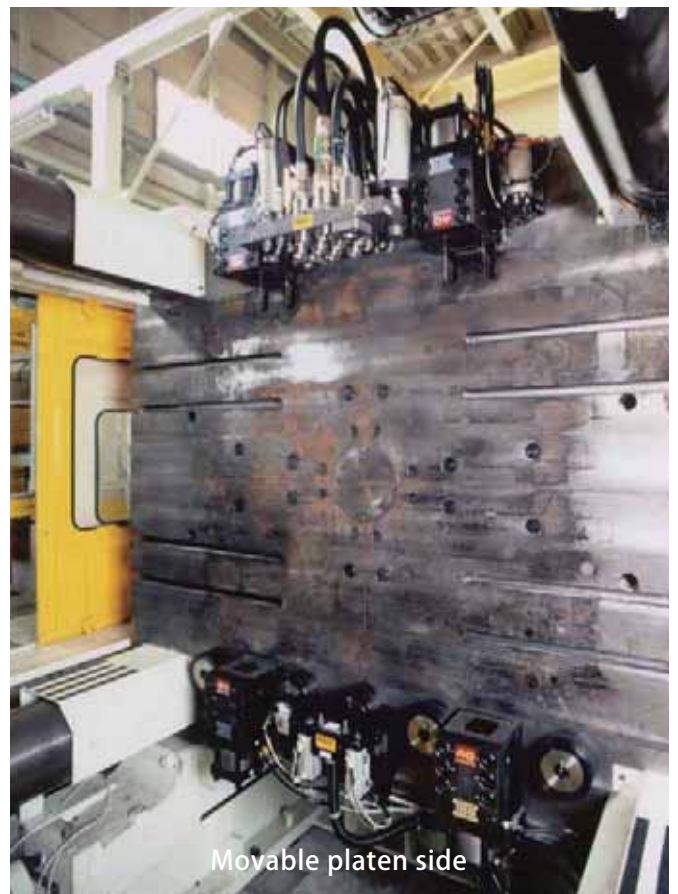

Movable platen side

For automatic coupling. Connection and disconnection of plural piping and tube

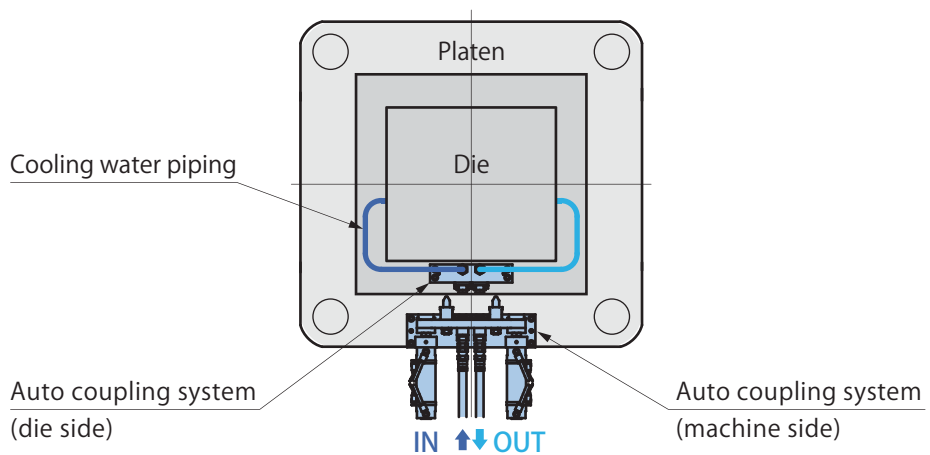
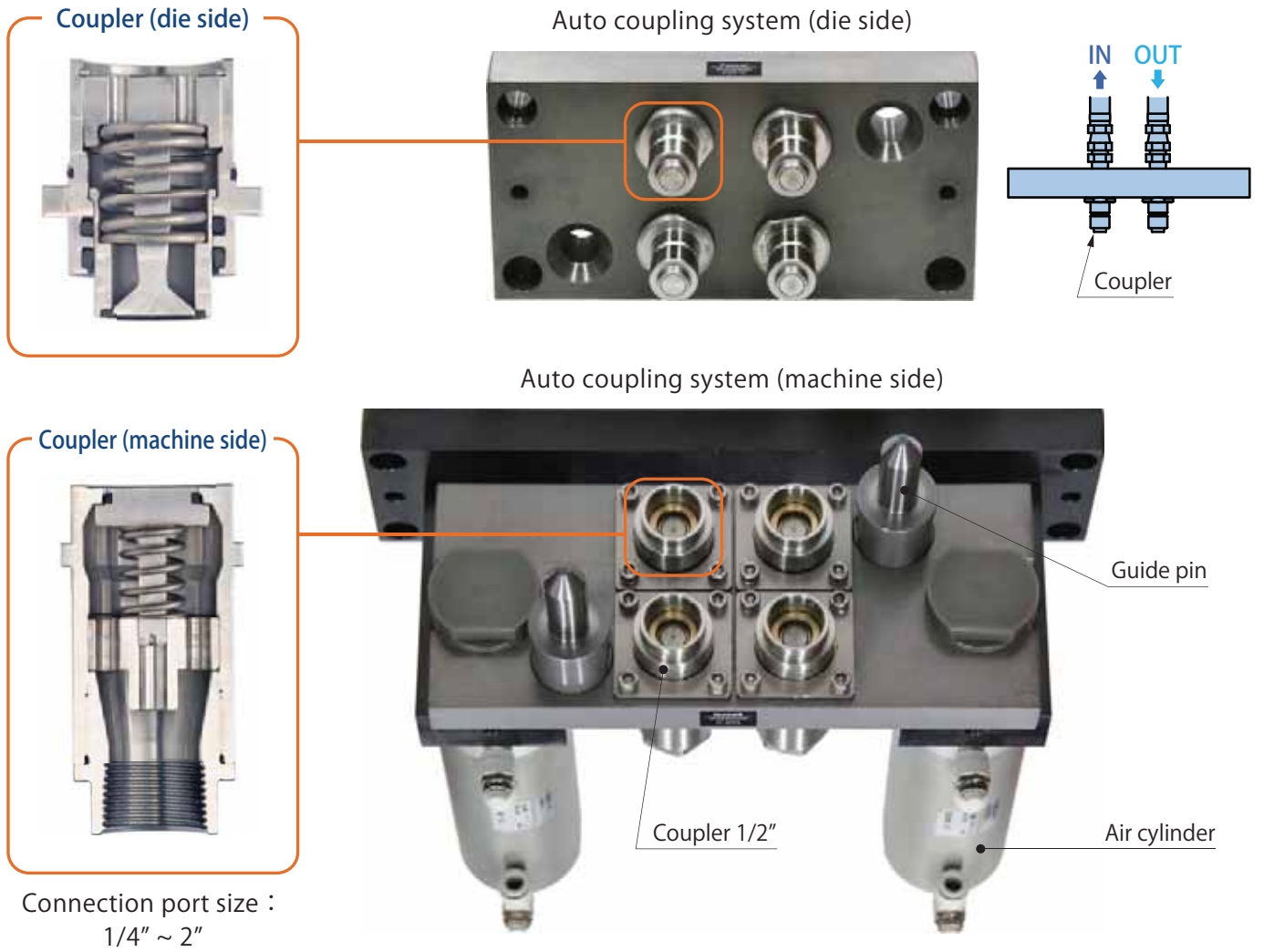

For Die clamp of Trimming press

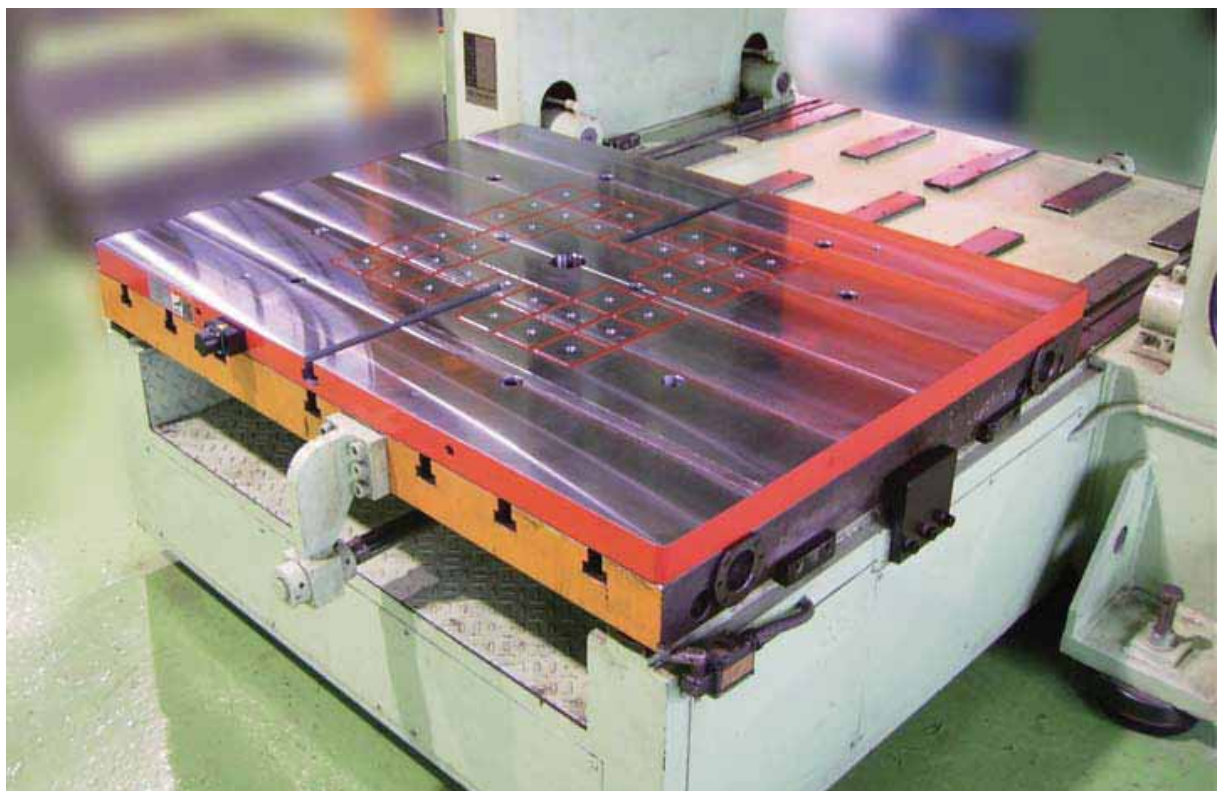

quick die-change system

For Die-change of Trimming press

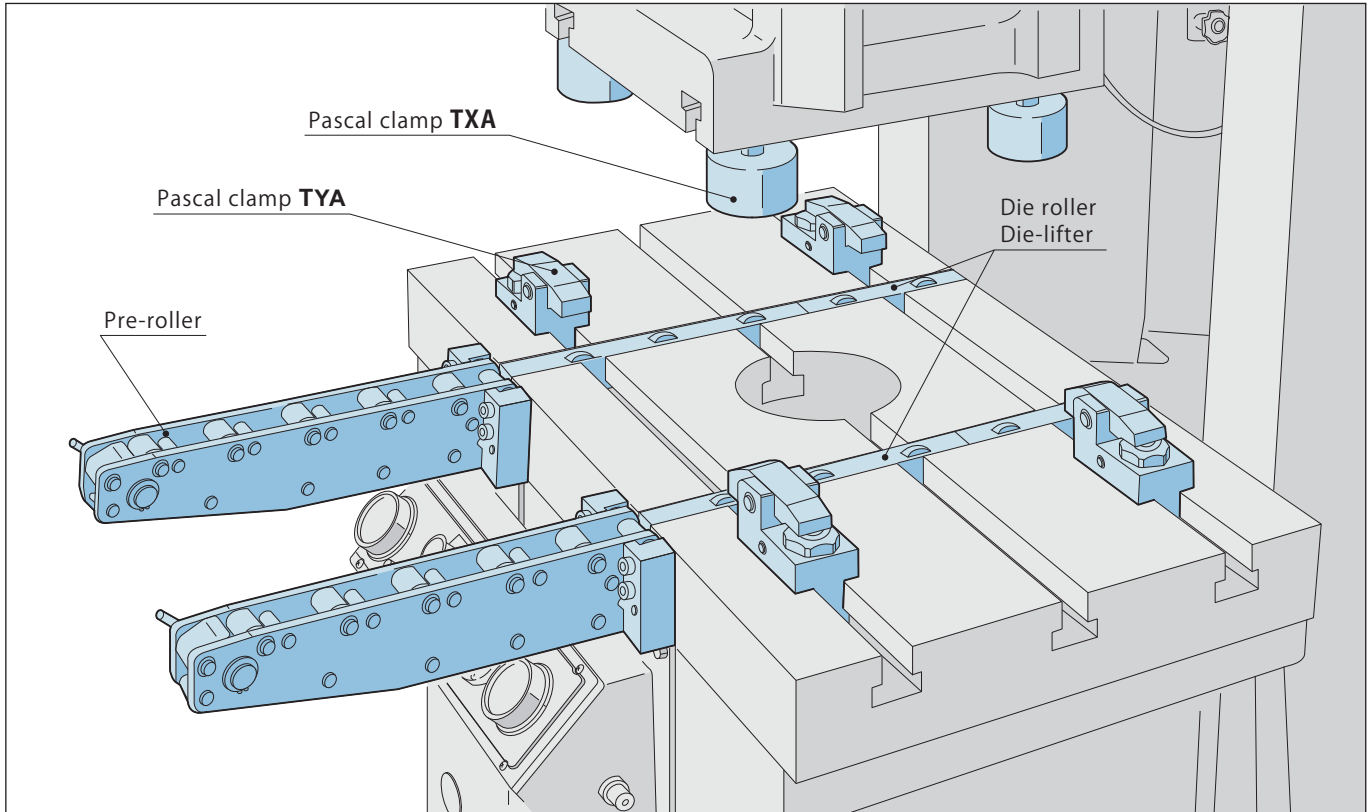

Pascal clamp model TXA

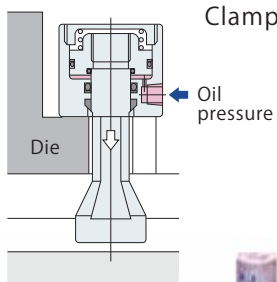

Clamping force: **9.8~245 kN**



Pascal clamp model TYA

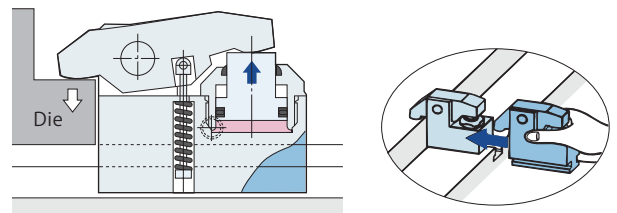

Clamping force: **9.8~780 kN**



air operated link clamp

For Work-clamping on deburring process

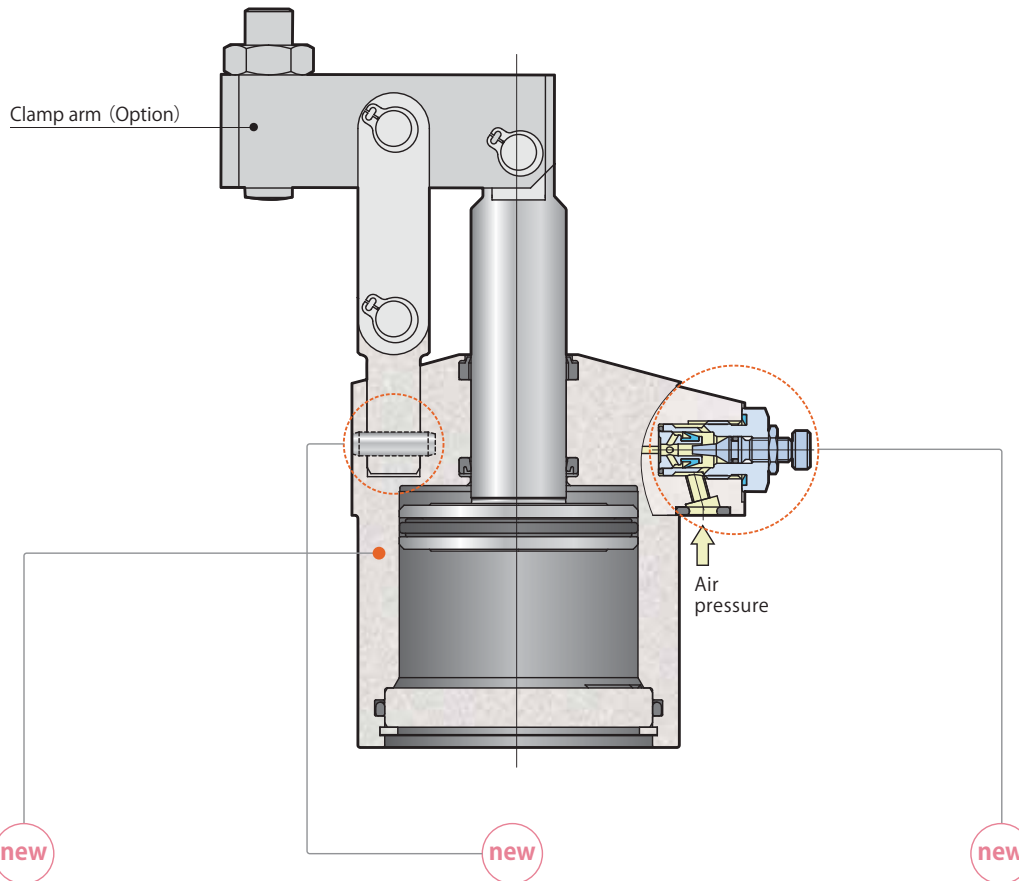

Compact body

Previous model

New model CLX

The cylinder body has been downsized in height by **26%~31%** in comparison to our previous model while remaining interchangeable in mounting. Your existing clamp arms can also be used.

Improved link support structure

Vertical clamping

Consistent clamping height ○

Interference with tool because of clamp arm inclination.
Horizontal force (work offset)

Inconsistent clamping height ✗

Enhanced link support structure improves accuracy of the height between mounting surface of flange and link pin to minimize fluctuation of clamp height. This eliminates offset of work-piece by slant clamping and tool interference caused by unlevelled clamp arm.

Direct-mount speed controller

Speed controller (option) model **VCL-O**

For manifold-mounting, a speed controller (option) can be mounted directly. You can adjust each clamp individually for easy control of sequence/synchronized actions.

model **CLX**
air 1MPa

air operated swing clamp

For Work-clamping on deburring process

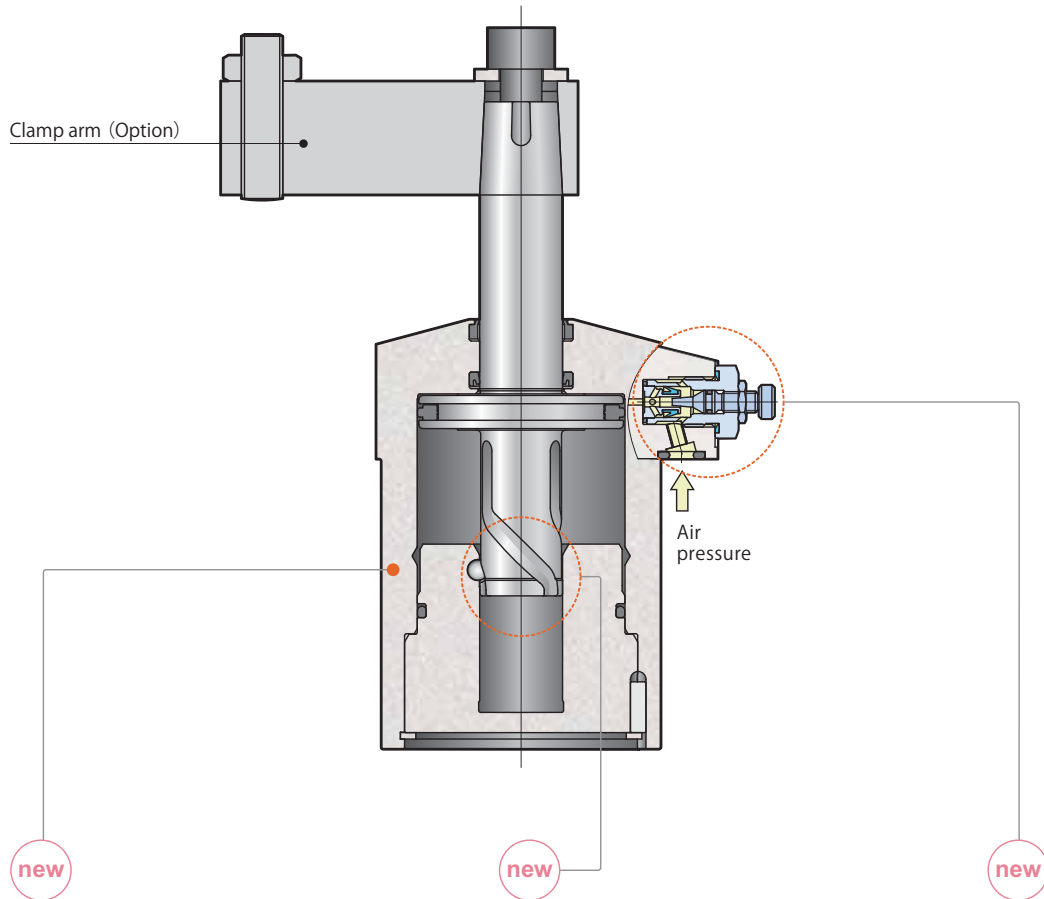

Compact body

The cylinder body has been downsized in height by **32%~35%** in comparison to our previous model while remaining interchangeable in mounting. Your existing clamp arms can also be used.

Smooth swing action with durability

Section : cam part

Three-ball support mechanism with radial arch cam grooves lowers contact surface pressure and ensures smooth and stable high-speed swing action with durability.

Direct-mount speed controller

Speed controller (option) model **VCL-O**

For manifold-mounting, a speed controller (option) can be mounted directly. You can adjust each clamp individually for easy control of sequence/synchronized actions.

model **CTX**
air 1MPa

hydraulic expansion clamp

For deburring process, clamp at the bottom of workpiece



model **CGS**



The expansion S clamp holds firmly the clamping hole at the bottom of workpiece and clamps it firmly down to the seating surface by utilizing taper rod and tapered surface of gripper. Clamp force is transmitted directly to seating surface and holds workpiece in place firmly without any distortion or deflection, making high grade and stable machining possible.

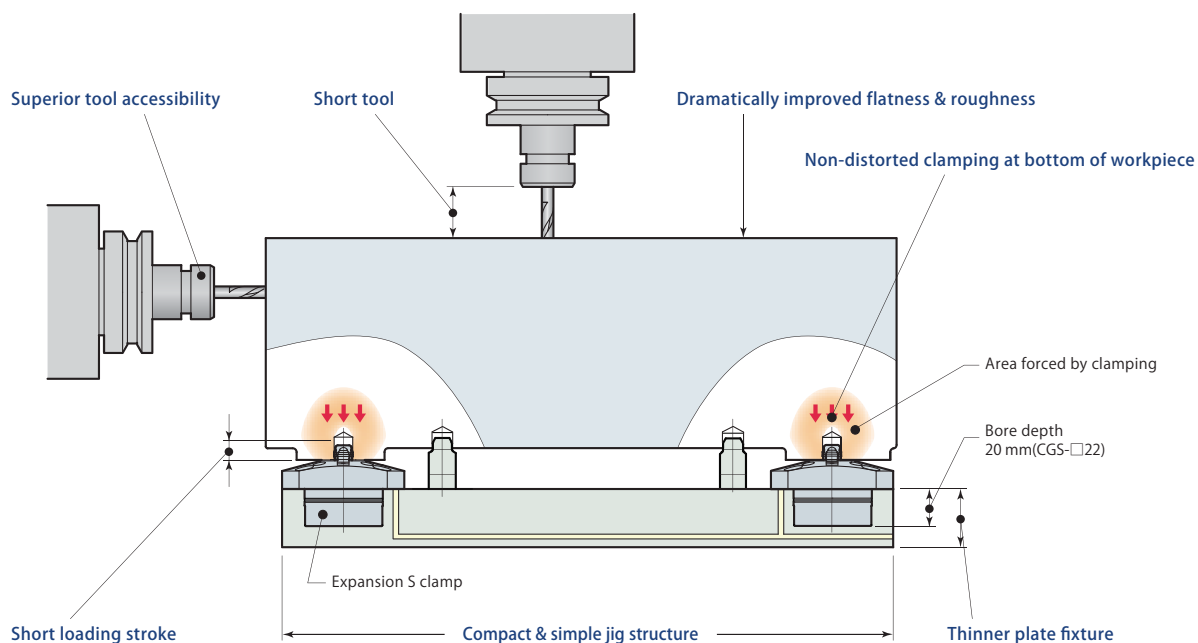
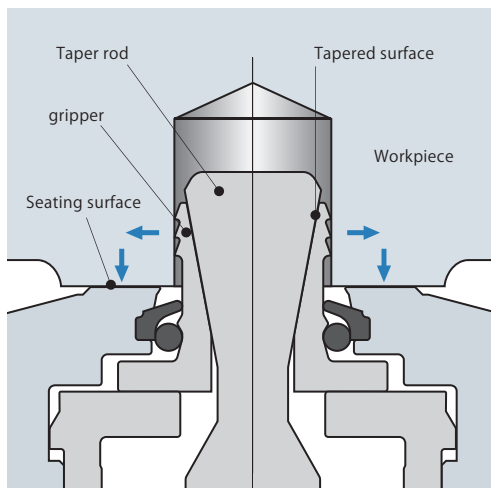

air operated
expansion clamp

Ideal for workpiece transfer, cleaning with robot

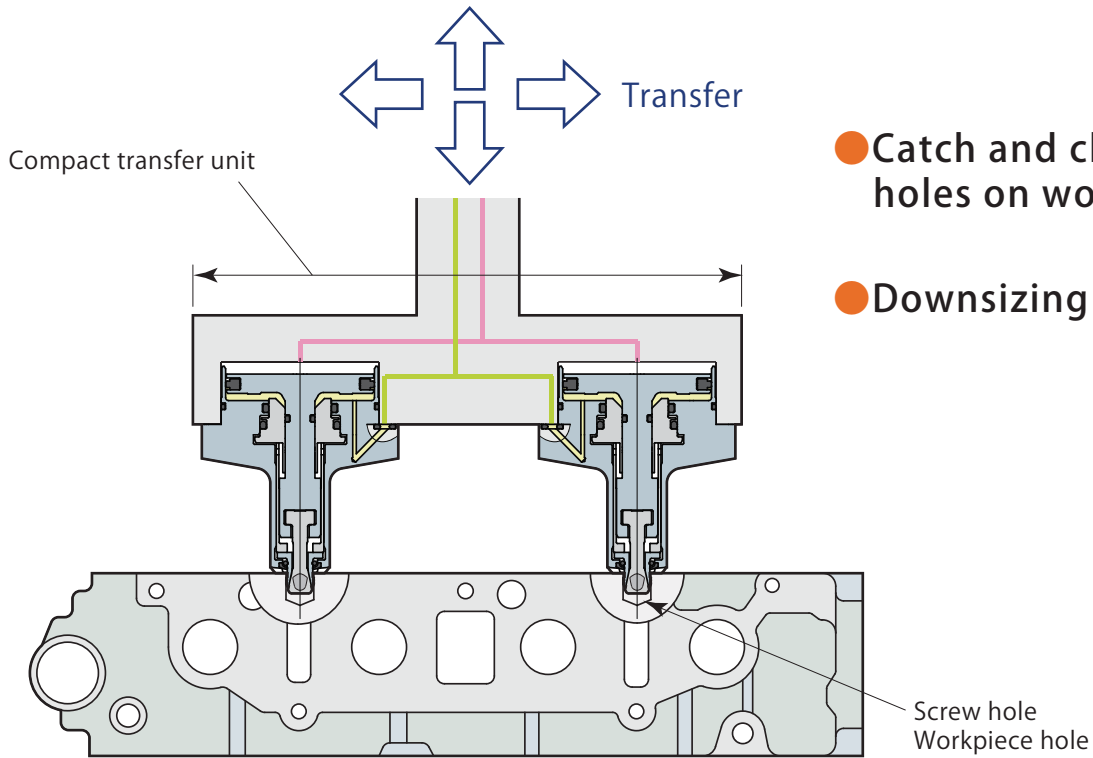

Cleaning machine

Positioning & clamping of workholding fixture for deburring

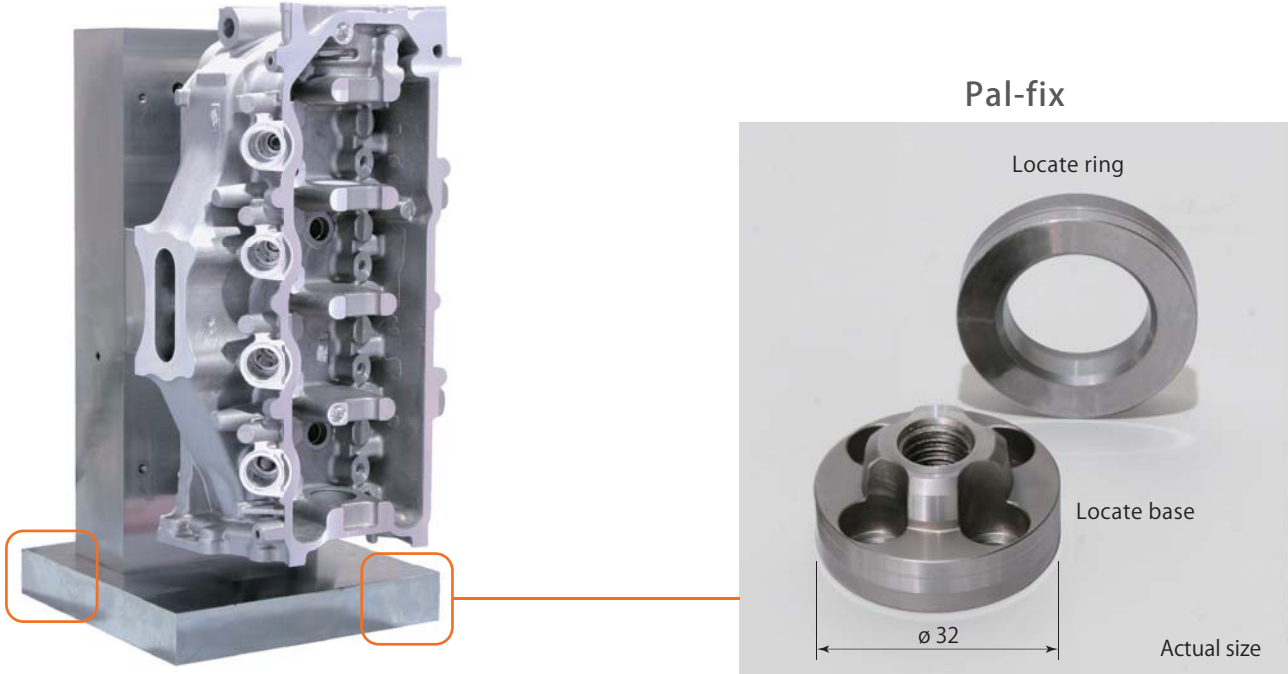

Reasonable price, High-accuracy, High-rigidity and Easy positioning

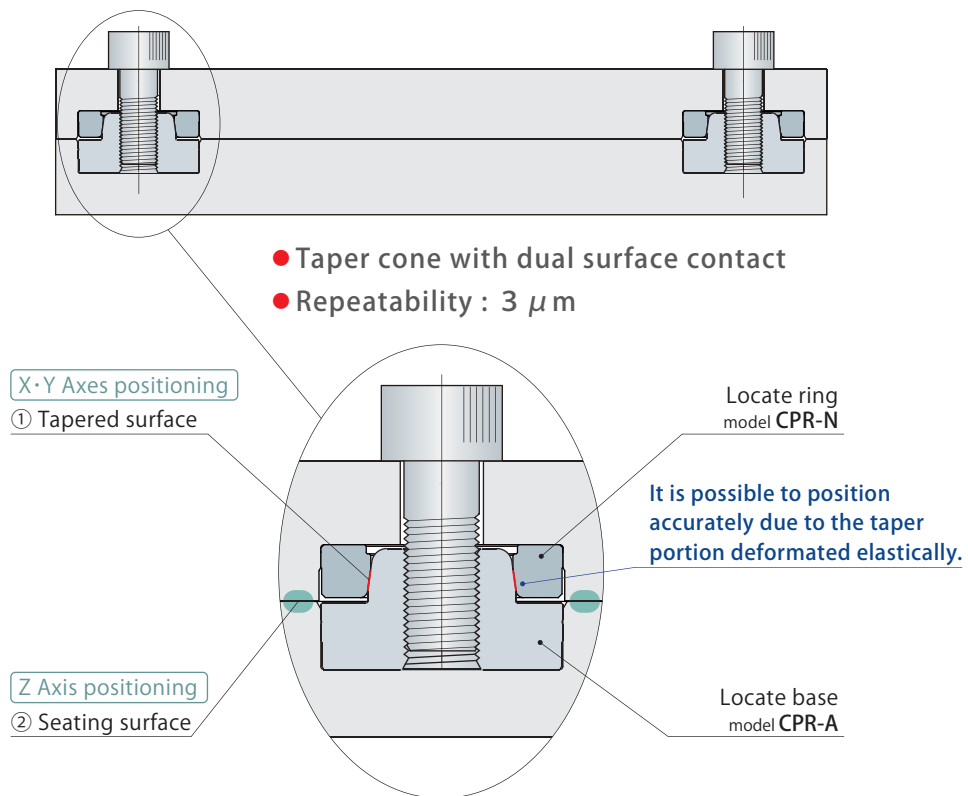

pallet clamp

Highly rigid pallet clamp and repeated positioning accuracy of $3\ \mu\text{m}$ with dual surface contact

Dual surface contact on tapered surface and seating surface ensures solid and stable clamping against loads from high rpm or heavy-duty cutting. Solution for high machining accuracy along with maximum productivity.



Implementation of Pal system makes it possible to perform setting of workpiece on fixtures of machine table accurately and significantly reduces setup time that was previously necessary for alignment.

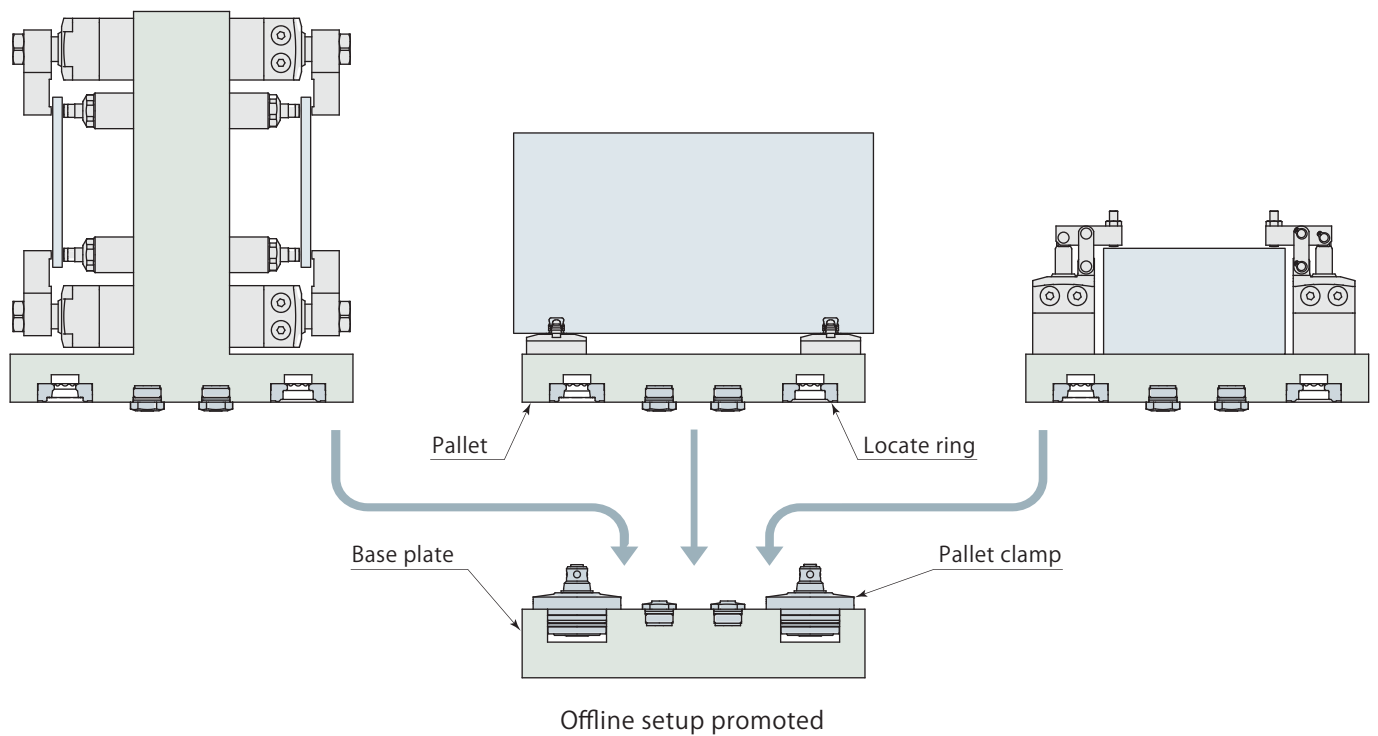

robot tool changer

PASCAL auto tool changer enhances the multi-functions of robot, shortens the set-up time and supports the high-mix low-volume production.

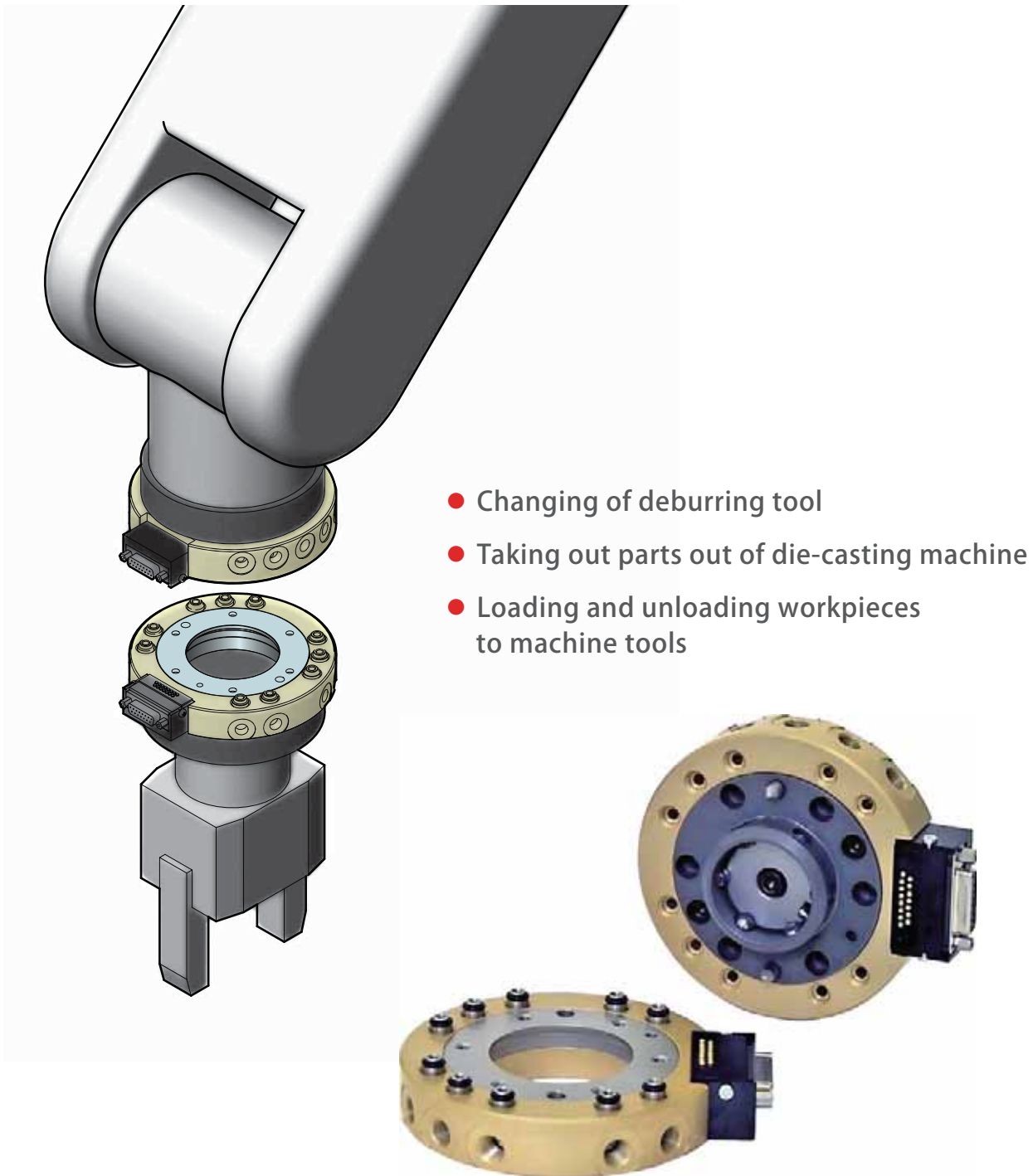

Portable weight : 20, 40, 60, 100, 150, 200 kg

die-handling system

Rotation of dies and casting parts weighing 1 - 50 tons

Rolling type model **SMR**



Flat type model **SMF**



Pascal

corporation

Itami, Hyogo, Japan 664-8502
TEL.(072)777-3333 FAX.(072)777-3520

