



# Die-lifter model **DLF**

Die-lifter



A powerful hydraulic cylinder in the body lifts up die from the bolster and makes die transfer easy.



Die-lifter DLF Selection

Model designation

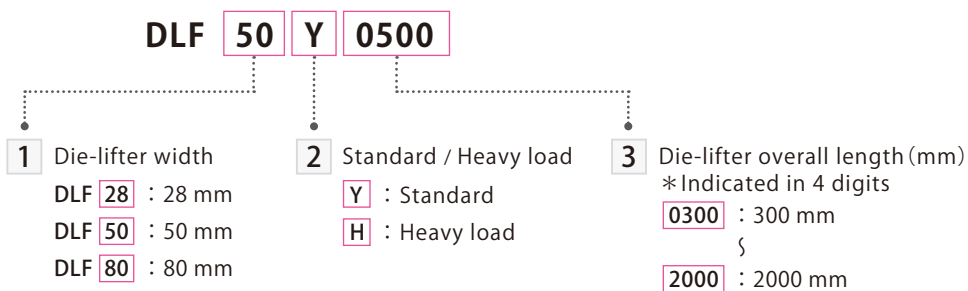

**1 2** Specifications

Model		DLF28	DLF50	DLF80
Lifting stroke N	mm	3		4
Max. load per roller	kN	0.98	1.86	5
Lifting force per cylinder (at hydraulic pressure 24.5MPa)	kN	4.45	12	33.9
Cylinder capacity (per cylinder)	cm <sup>3</sup>	0.54	1.5	5.6
Weight per 100 mm	Y (Standard)	0.66	1.5	3.6
	H (Heavy load)	0.7	1.6	3.8
Standard length	mm	300 ~ 2000	400 ~ 2000	500 ~ 2000
Die-lifter width A	mm	28	50	80
Slot depth B	mm	45	53	80
Roller diameter	mm	ø21	ø22	ø34
Roller width	mm	17	28	54

- Max. hydraulic pressure : 24.5MPa   ● Proof pressure : 36.7MPa   ● Operating temperature : 0 ~ 70°C
- DLF50 roller is more durable than the one of DLF28, so DLF50 is recommendable.   ● DLF80 is the specification for large press machine (more than 8000kN).
- Roller max load is determined given die plate material as SS400(JIS). Consult Pascal in case the material is S45C.

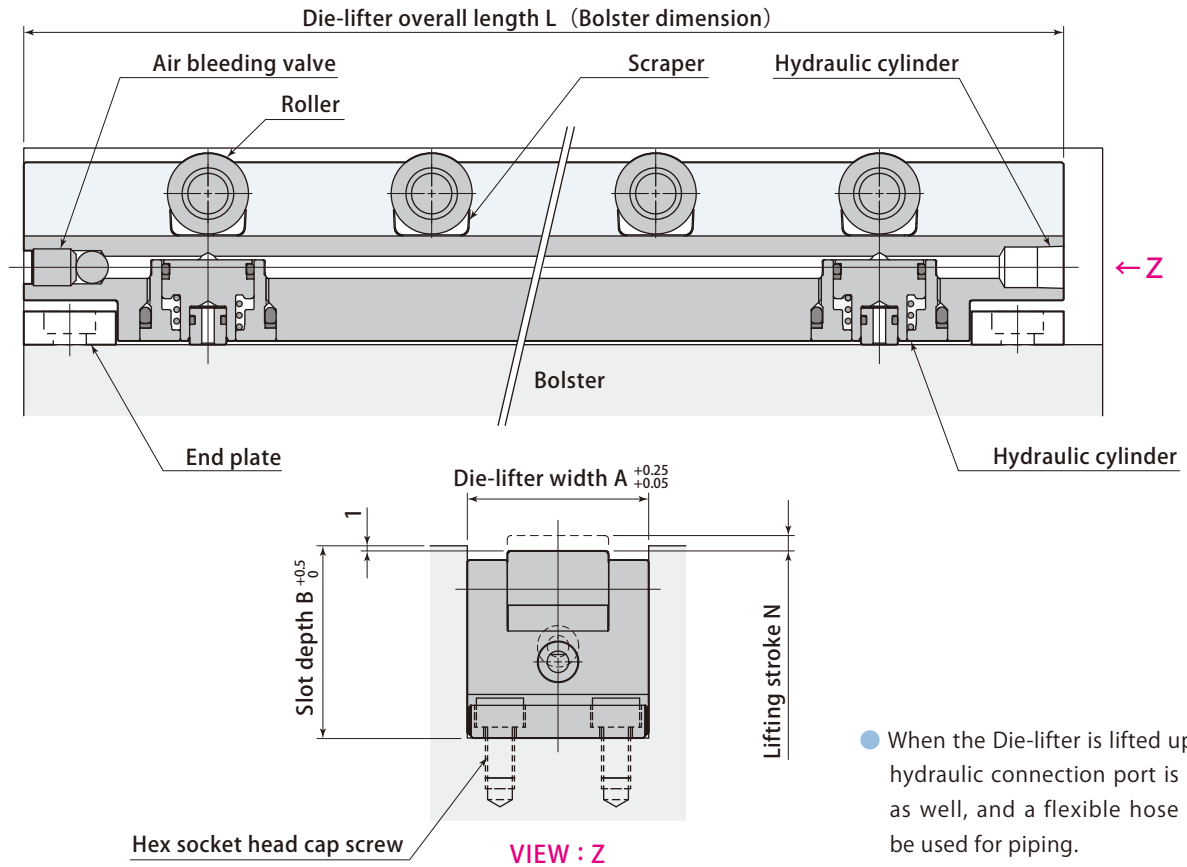

● When the Die-lifter is lifted up, the hydraulic connection port is lifted as well, and a flexible hose must be used for piping.

**3** Die-lifter overall length 300 ~ 2000 mm

Die-lifter overall length L		mm	300	400	500	600	700	800	900	1000	1100	1200	1300	1400	1500	1600	1700	1800	2000				
DLF28Y	Number of rollers		3	4	5	6	7	8	9	10	11	12	13	14	15	16	17	18	20				
	Max. load per 100 mm	kN	0.98																				
	Max. load per overall length *	kN	2.94	3.92	4.9	5.88	6.86	7.84	8.82	9.8	10.8	11.8	12.7	13.7	14.7	15.7	16.7	17.6	19.6				
	Number of cylinders		3			4				5					6								
DLF28H	Number of rollers		6	8	10	12	14	15	17	19	21	23	25	27	29	31	33	35	39				
	Max. load per 100 mm	kN	1.96																				
	Max. load per overall length *	kN	5.88	7.84	9.8	11.8	13.7	14.7	16.7	18.6	20.6	22.5	24.5	26.5	28.4	30.4	32.3	34.3	38.2				
	Number of cylinders		4		5		6		7		8		9		10		11		12		13		14
DLF50Y	Number of rollers		—	4	5	6	7	8	9	10	11	12	13	14	15	16	17	18	20				
	Max. load per 100 mm	kN	—	1.86																			
	Max. load per overall length *	kN	—	7.44	9.3	11.2	13	14.9	16.7	18.6	20.5	22.3	24.2	26	27.9	29.8	31.6	33.5	37.2				
	Number of cylinders		—	3				4					5										
DLF50H	Number of rollers		—	8	10	12	14	16	18	20	22	24	26	28	30	32	34	36	40				
	Max. load per 100 mm	kN	—	3.72																			
	Max. load per overall length *	kN	—	14.9	18.6	22.3	26	29.8	33.5	37.2	40.9	44.6	48.4	52.1	55.8	59.5	63.2	67	74.4				
	Number of cylinders		—	3		4			5			6			7			8		9			
DLF80Y	Number of rollers		—	—	3	4	5	6	7	8	9	10	11	12	13	14	15	16	18				
	Max. load per 100 mm	kN	—	—	3	3.33	3.57	3.75	3.89	4	4.09	4.17	4.23	4.29	4.33	4.38	4.41	4.44	4.5				
	Max. load per overall length *	kN	—	—	15	20	25	30	35	40	45	50	55	60	65	70	75	80	90				
	Number of cylinders		—	—	2		3			4				5									
DLF80H	Number of rollers		—	—	8	10	11	13	15	16	18	20	21	23	24	26	28	29	32				
	Max. load per 100 mm	kN	—	—	8	8.33	7.86	8.13	8.33	8	8.18	8.33	8.08	8.21	8	8.13	8.24	8.06	8				
	Max. load per overall length *	kN	—	—	40	50	55	65	75	80	90	100	105	115	120	130	140	145	160				
	Number of cylinders		—	—	3		4		5		6		7		8		9		10				

\* The value indicates Max. load when all of rollers are in contact with the die.

**Width 28mm Standard**

Model designation

**DLF 28 Y 0500**

Die-lifter overall length (mm)  
0300~2000 \* Indicated in 4 digits

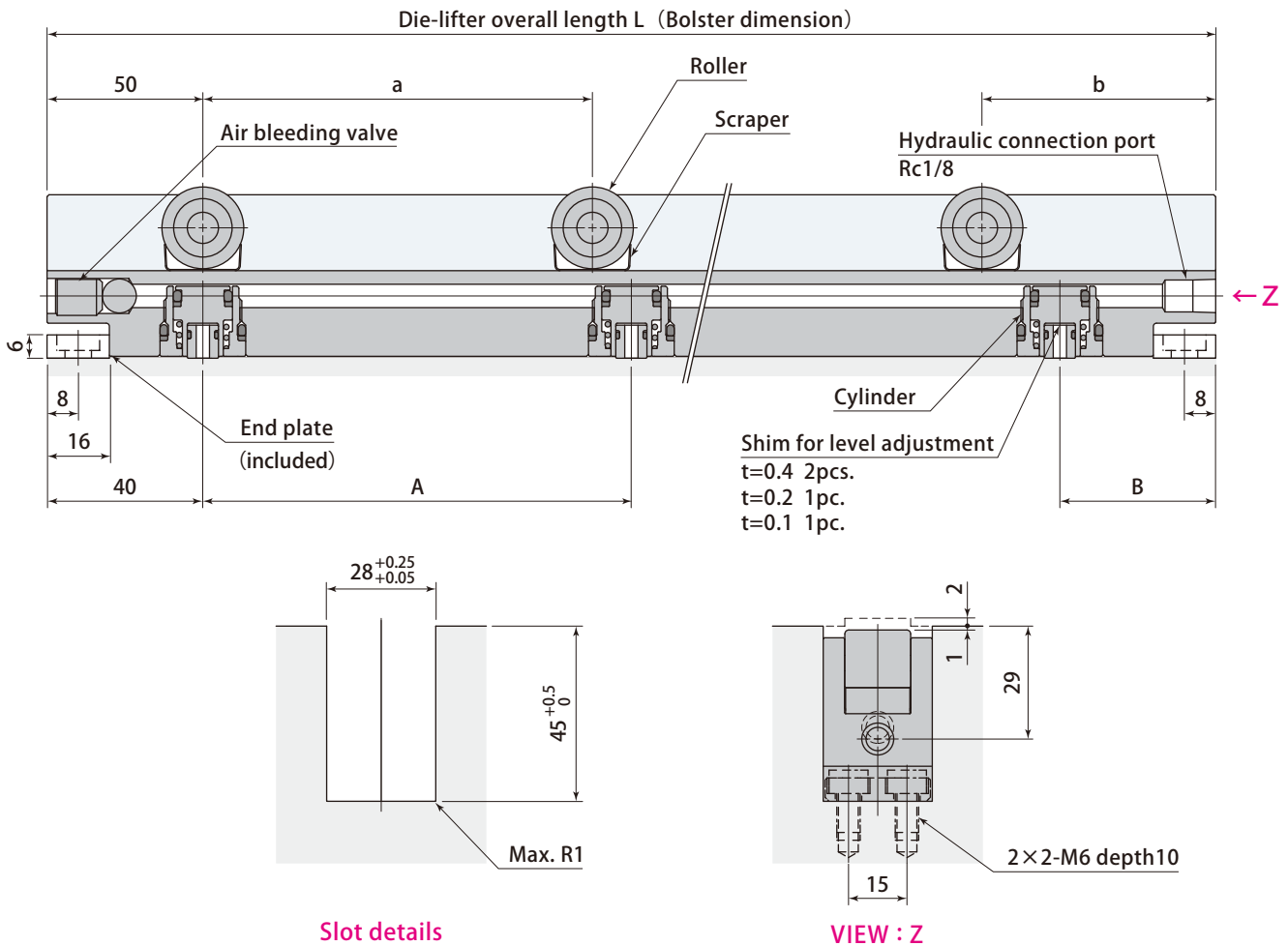

Die-lifter overall length 300 ~ 2000 mm

Die-lifter overall length L	mm	300	400	500	600	700	800	900	1000	1100	1200	1300	1400	1500	1600	1700	1800	2000	
Number of rollers		3	4	5	6	7	8	9	10	11	12	13	14	15	16	17	18	20	
Max. load per 100 mm	kN	0.98	0.98	0.98	0.98	0.98	0.98	0.98	0.98	0.98	0.98	0.98	0.98	0.98	0.98	0.98	0.98	0.98	
Max. load per overall length *	kN	2.94	3.92	4.9	5.88	6.86	7.84	8.82	9.8	10.8	11.8	12.7	13.7	14.7	15.7	16.7	17.6	19.6	
Roller pitch	a	mm	100	100	100	100	100	100	100	100	100	100	100	100	100	100	100	100	
	b	mm	50	50	50	50	50	50	50	50	50	50	50	50	50	50	50	50	
Number of cylinders		3	3	3	3	4	4	4	4	5	5	5	5	5	5	5	6	6	
Lifting force per cylinder	kN	13.4	13.4	13.4	13.4	17.8	17.8	17.8	17.8	22.3	22.3	22.3	22.3	22.3	22.3	22.3	26.7	26.7	
Cylinder capacity	cm <sup>3</sup>	1.62	1.62	1.62	1.62	2.16	2.16	2.16	2.16	2.7	2.7	2.7	2.7	2.7	2.7	2.7	3.24	3.24	
Cylinder pitch	A	mm	110	160	210	260	207	240	274	307	255	280	305	330	355	380	405	344	384
	B	mm	40	40	40	40	39	40	38	39	40	40	40	40	40	40	40	40	40
Weight	kg	2	2.6	3.3	4	4.6	5.3	5.9	6.6	7.3	7.9	8.6	9.2	9.9	10.6	11.2	11.9	13.2	
End plate mount screw		4-M6 length10																	

- Max. hydraulic pressure : 24.5MPa
- Lifting force is under hydraulic force at 24.5 MPa.
- Proof pressure : 36.7MPa
- Operating temperature : 0 ~ 70°C
- \* The value indicates Max. load when all of rollers are in contact with the die.

**Width 28mm Heavy load**

Model designation

**DLF 28 H 0500**

Die-lifter overall length (mm)  
0300~2000 \*Indicated in 4 digits

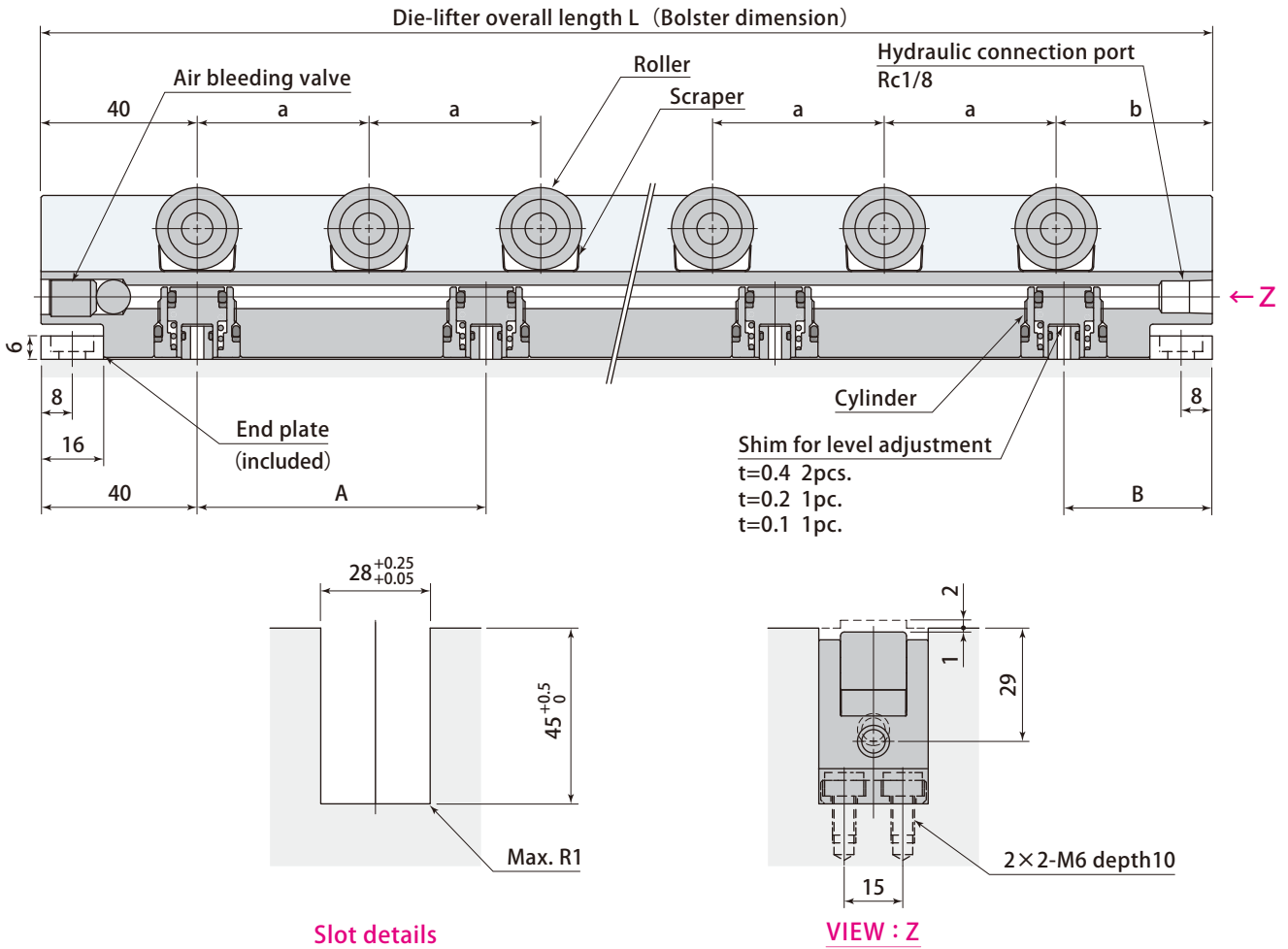

Die-lifter DLF28

Die-lifter overall length **300 ~ 2000** mm

Die-lifter overall length L	mm	300	400	500	600	700	800	900	1000	1100	1200	1300	1400	1500	1600	1700	1800	2000
Number of rollers		6	8	10	12	14	15	17	19	21	23	25	27	29	31	33	35	39
Max. load per 100 mm	kN	1.96	1.96	1.96	1.96	1.96	1.84	1.85	1.86	1.87	1.88	1.88	1.89	1.89	1.9	1.9	1.91	1.91
Max. load per overall length *	kN	5.88	7.84	9.8	11.8	13.7	14.7	16.7	18.6	20.6	22.5	24.5	26.5	28.4	30.4	32.3	34.3	38.2
Roller pitch	a	mm	44	45	46	47	47	51	51	51	51	50	50	50	50	50	50	50
	b	mm	40	45	46	43	49	46	44	42	40	60	60	60	60	60	60	60
Number of cylinders		4	4	5	5	6	7	7	8	9	9	10	11	11	12	13	13	14
Lifting force per cylinder	kN	17.8	17.8	22.3	22.3	26.7	31.2	31.2	35.6	40.1	40.1	44.5	49	49	53.4	57.9	57.9	62.3
Cylinder capacity	cm <sup>3</sup>	2.16	2.16	2.7	2.7	3.24	3.78	3.78	4.32	4.86	4.86	5.4	5.94	5.94	6.48	7.02	7.02	7.56
Cylinder pitch	A	mm	74	106	105	130	124	120	136	132	128	140	135	132	142	138	135	143
	B	mm	38	42	40	40	40	40	44	36	36	40	45	40	40	42	40	44
Weight	kg	2.1	2.8	3.5	4.2	4.9	5.6	6.3	7	7.7	8.4	9.1	9.8	10.5	11.2	11.9	12.6	14
End plate mount screw		4-M6 length 10																

- Max. hydraulic pressure : 24.5MPa ● Lifting force is under hydraulic force at 24.5 MPa. ● Proof pressure : 36.7MPa
- Operating temperature : 0 ~ 70°C

\* The value indicates Max. load when all of rollers are in contact with the die.

**Width 50mm Standard**

Model designation

**DLF 50 Y 0500**

Die-lifter overall length (mm)  
0300~2000 \* Indicated in 4 digits

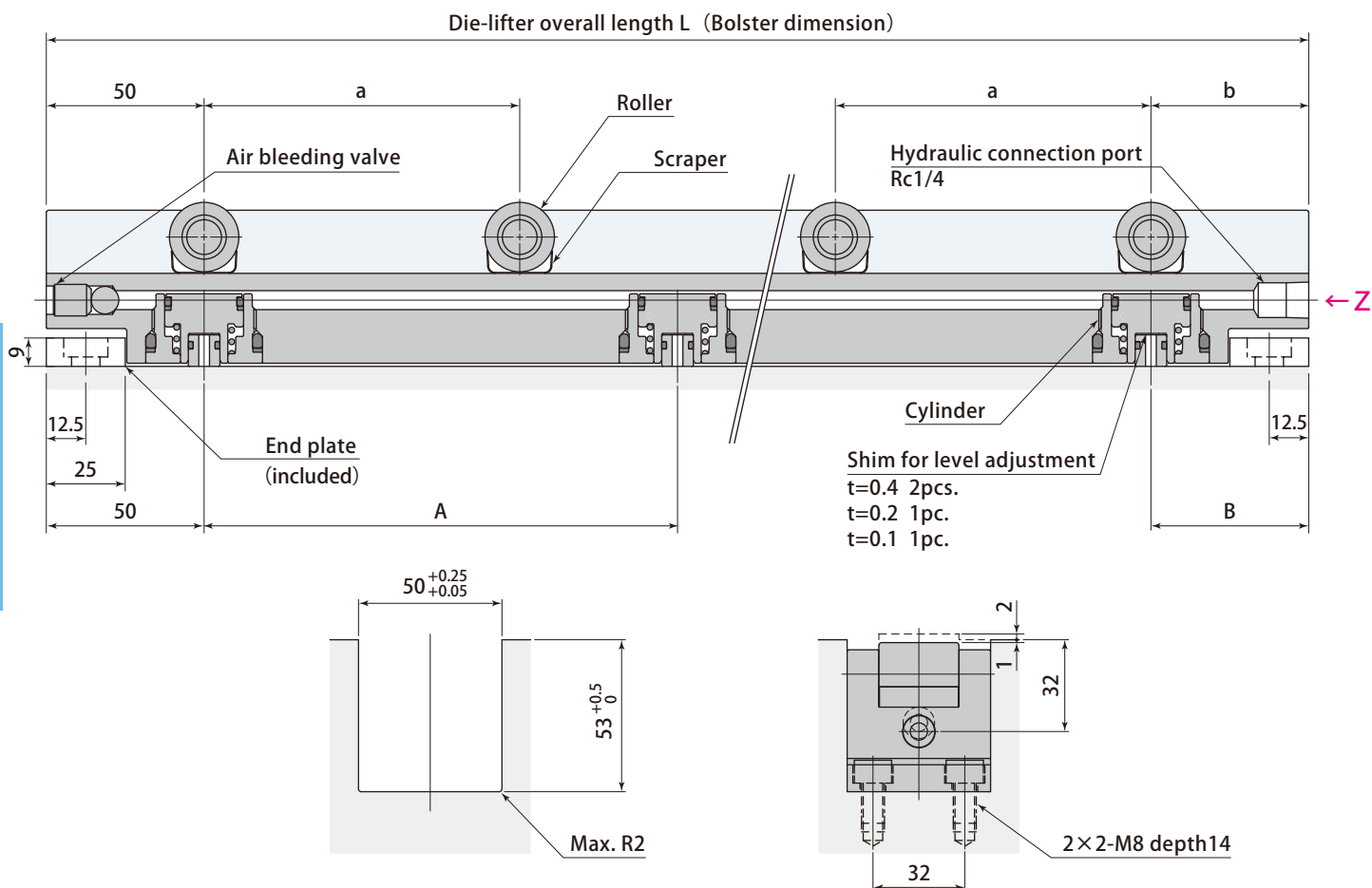

Slot details

VIEW : Z

Die-lifter overall length 400 ~ 2000 mm

Die-lifter overall length L	mm	400	500	600	700	800	900	1000	1100	1200	1300	1400	1500	1600	1700	1800	2000	
Number of rollers		4	5	6	7	8	9	10	11	12	13	14	15	16	17	18	20	
Max. load per 100 mm	kN	1.86	1.86	1.86	1.86	1.86	1.86	1.86	1.86	1.86	1.86	1.86	1.86	1.86	1.86	1.86	1.86	
Max. load per overall length*	kN	7.44	9.3	11.2	13	14.9	16.7	18.6	20.5	22.3	24.2	26	27.9	29.8	31.6	33.5	37.2	
Roller pitch	a	mm	100	100	100	100	100	100	100	100	100	100	100	100	100	100	100	
	b	mm	50	50	50	50	50	50	50	50	50	50	50	50	50	50	50	
Number of cylinders		3	3	3	3	3	4	4	4	4	4	4	5	5	5	5	5	
Lifting force per cylinder	kN	36	36	36	36	36	48	48	48	48	48	48	60	60	60	60	60	
Cylinder capacity	cm <sup>3</sup>	4.5	4.5	4.5	4.5	4.5	6	6	6	6	6	6	7.5	7.5	7.5	7.5	7.5	
Cylinder pitch	A	mm	150	200	250	300	350	267	300	334	367	400	434	350	375	400	425	475
	B	mm	50	50	50	50	50	49	50	48	49	50	48	50	50	50	50	50
Weight	kg	6	7.5	9	10.5	12	13.5	15	16.5	18	19.5	21	22.5	24	25.5	27	30	
End plate mount screw		4-M8 length14																

- Max. hydraulic pressure : 24.5MPa ● Lifting force is under hydraulic force at 24.5 MPa. ● Proof pressure : 36.7MPa
- Operating temperature : 0 ~ 70°C \* The value indicates Max. load when all of rollers are in contact with the die.

**Width 50mm Heavy load**

Model designation

**DLF 50 H 0500**

Die-lifter overall length (mm)  
0400~2000 \* Indicated in 4 digits

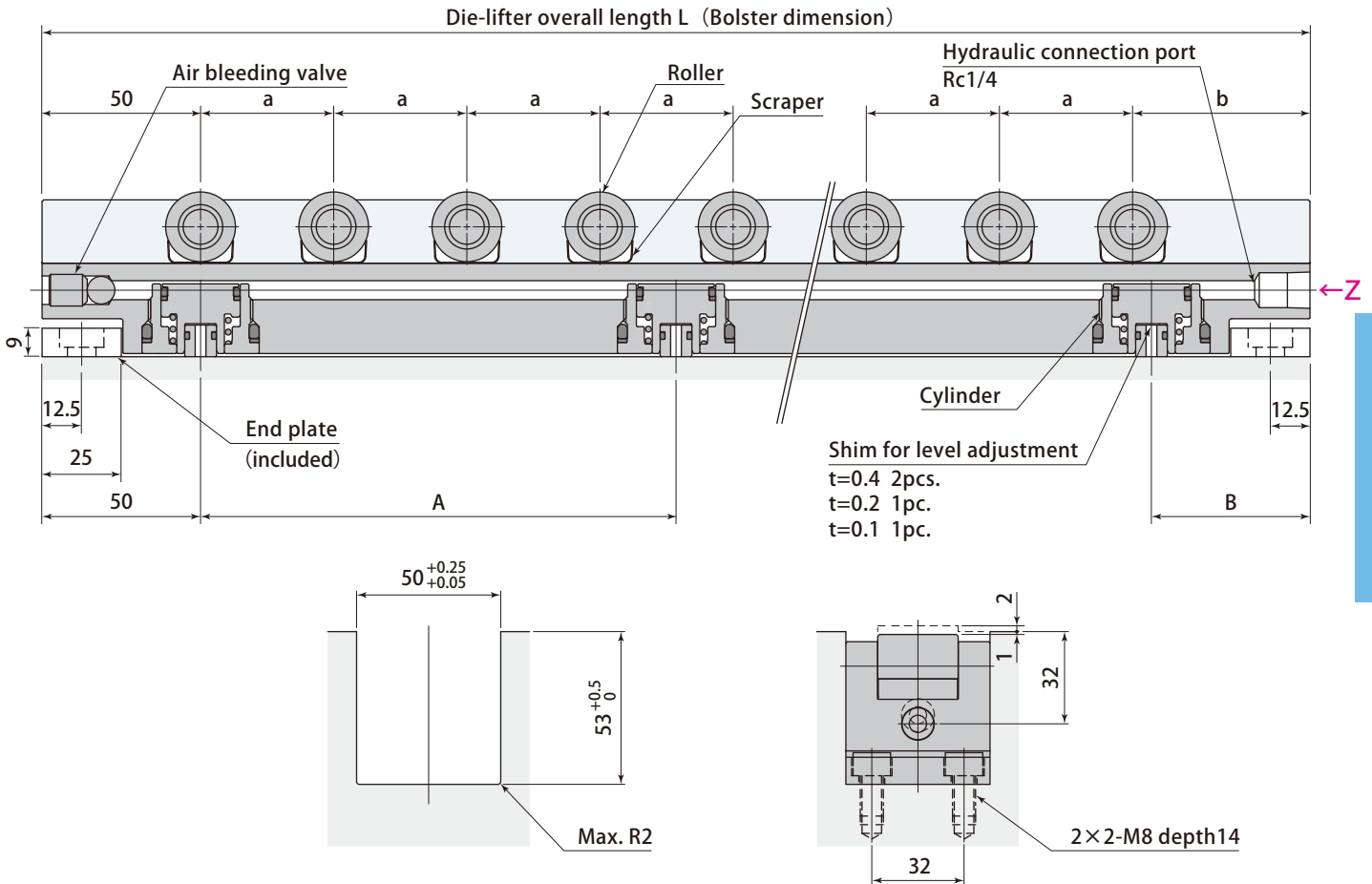

Die-lifter DLF50

Slot details

VIEW : Z

Die-lifter overall length **400 ~ 2000** mm

Die-lifter overall length L	mm	400	500	600	700	800	900	1000	1100	1200	1300	1400	1500	1600	1700	1800	2000
Number of rollers		8	10	12	14	16	18	20	22	24	26	28	30	32	34	36	40
Max. load per 100 mm	kN	3.72	3.72	3.72	3.72	3.72	3.72	3.72	3.72	3.72	3.72	3.72	3.72	3.72	3.72	3.72	3.72
Max. load per overall length *	kN	14.9	18.6	22.3	26	29.8	33.5	37.2	40.9	44.6	48.4	52.1	55.8	59.5	63.2	67	74.4
Roller pitch	a	mm	42	44	45	46	46	47	47	47	47	48	48	48	48	48	48
	b	mm	56	54	55	52	60	51	57	63	69	50	54	58	62	66	70
Number of cylinders		3	3	4	4	4	5	5	6	6	6	7	7	7	8	8	9
Lifting force per cylinder	kN	36	36	48	48	48	60	60	72	72	72	84	84	84	96	96	108
Cylinder capacity	cm <sup>3</sup>	4.5	4.5	6	6	6	7.5	7.5	9	9	9	10.5	10.5	10.5	12	12	13.5
Cylinder pitch	A	mm	150	200	166	200	233	200	225	200	220	240	216	233	250	228	242
	B	mm	50	50	52	50	51	50	50	50	50	54	52	50	54	56	54
Weight	kg	6.4	8	9.6	11.2	12.8	14.4	16	17.6	19.2	20.8	22.4	24	25.6	27.2	28.8	32
End plate mount screw		4-M8 length14															

● Max. hydraulic pressure : 24.5MPa ● Lifting force is under hydraulic force at 24.5 MPa. ● Proof pressure : 36.7MPa

● Operating temperature : 0 ~ 70°C

\* The value indicates Max. load when all of rollers are in contact with the die.



**Width 80mm Standard**

Model designation

**DLF 80 Y 0500**

Die-lifter overall length (mm)  
0500~2000 \* Indicated in 4 digits

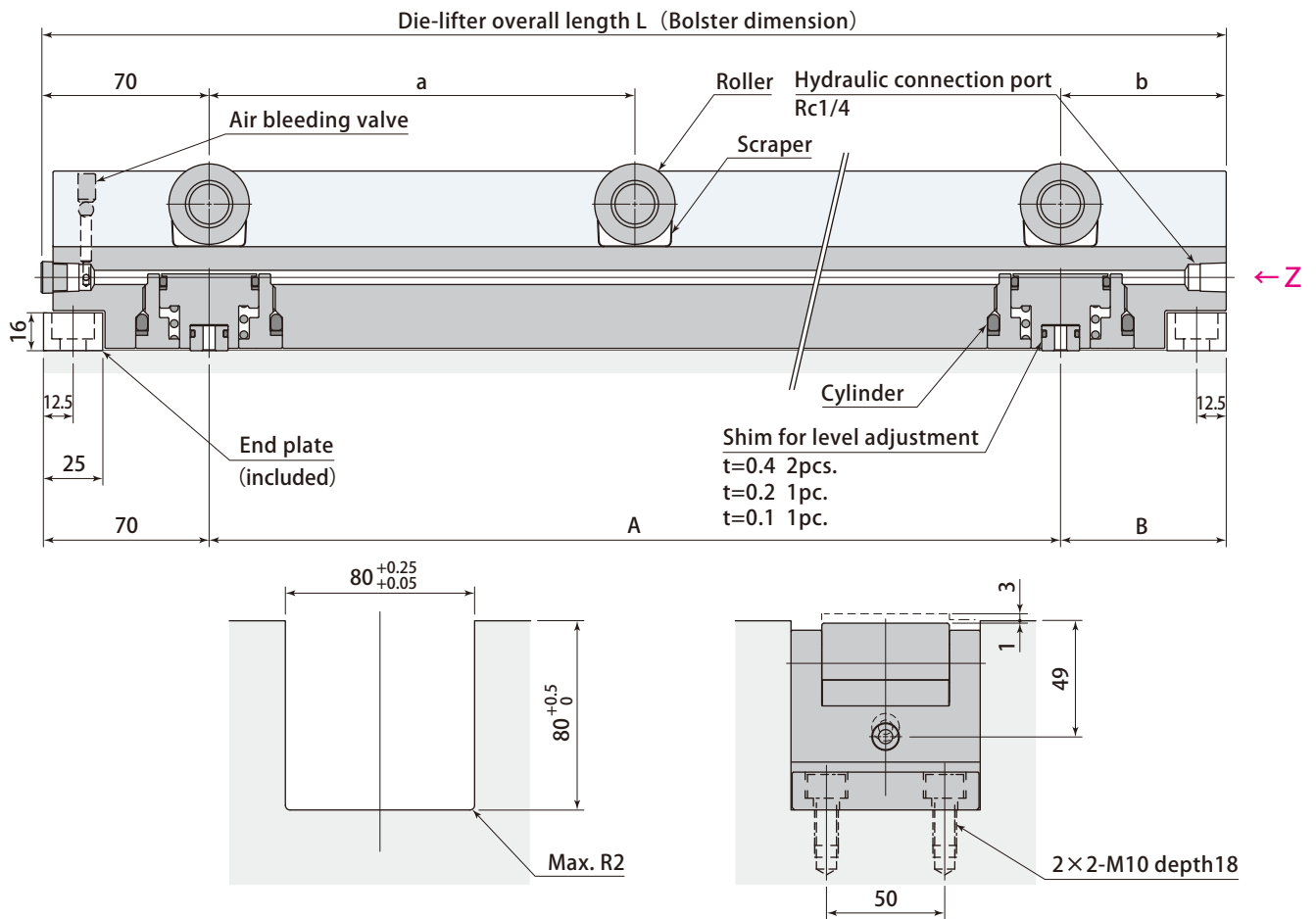

Slot details

Die-lifter overall length 500 ~ 2000 mm

Die-lifter overall length L	mm	500	600	700	800	900	1000	1100	1200	1300	1400	1500	1600	1700	1800	2000	
Number of rollers		3	4	5	6	7	8	9	10	11	12	13	14	15	16	18	
Max. load per 100 mm	kN	3	3.33	3.57	3.75	3.89	4	4.09	4.17	4.23	4.29	4.33	4.38	4.41	4.44	4.5	
Max. load per overall length *	kN	15	20	25	30	35	40	45	50	55	60	65	70	75	80	90	
Roller pitch	a	mm	180	153	140	132	126	122	120	117	116	114	113	112	111	110	
	b	mm	70	71	70	70	74	76	70	77	70	76	74	74	76	80	77
Number of cylinders		2	2	3	3	3	3	3	4	4	4	4	5	5	5	5	
Lifting force per cylinder	kN	67.8	67.8	101.7	101.7	101.7	101.7	101.7	135.6	135.6	135.6	135.6	169.5	169.5	169.5	169.5	
Cylinder capacity	cm <sup>3</sup>	11.2	11.2	16.8	16.8	16.8	16.8	16.8	22.4	22.4	22.4	22.4	28	28	28	28	
Cylinder pitch	A	mm	360	460	280	330	380	430	480	353	387	420	453	365	390	415	465
	B	mm	70	70	70	70	70	70	70	71	69	70	71	70	70	70	70
Weight	kg	18	21.6	25.2	28.8	32.4	36	39.6	43.2	46.8	50.4	54	57.6	61.2	64.8	72	
End plate mount screw		4-M10 length 20															

- Max. hydraulic pressure : 24.5MPa ● Lifting force is under hydraulic force at 24.5 MPa. ● Proof pressure : 36.7MPa
- Operating temperature : 0 ~ 70°C

\* The value indicates Max. load when all of rollers are in contact with the die.

**Width 80mm Heavy load**

Model designation

**DLF 80 H 0500**

Die-lifter overall length (mm)  
0500~2000 \* Indicated in 4 digits

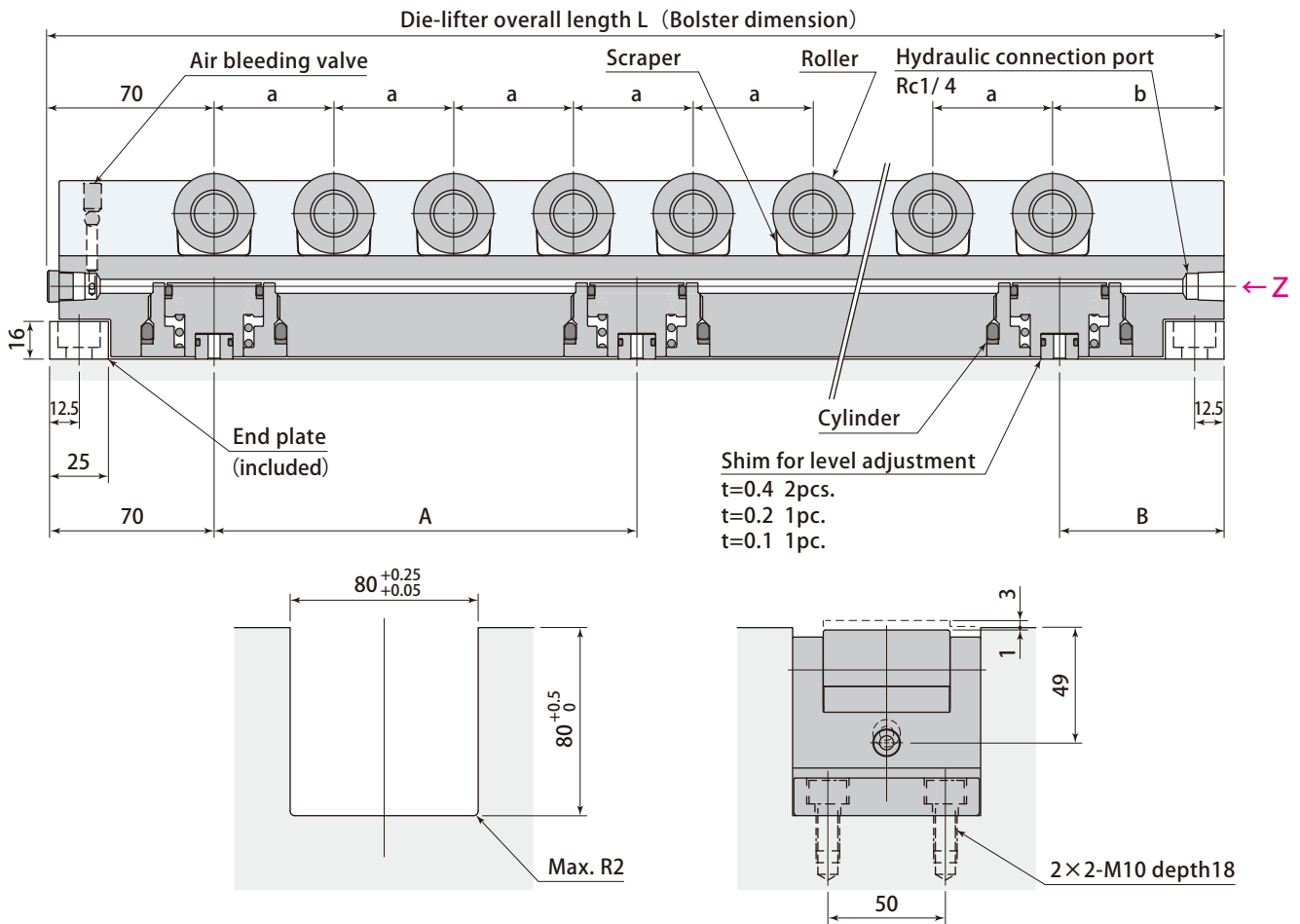

Slot details

VIEW : Z

Die-lifter overall length 500 ~ 2000 mm

Die-lifter overall length L	mm	500	600	700	800	900	1000	1100	1200	1300	1400	1500	1600	1700	1800	2000	
Number of rollers		8	10	11	13	15	16	18	20	21	23	24	26	28	29	32	
Max. load per 100 mm	kN	8	8.33	7.86	8.13	8.33	8	8.18	8.33	8.08	8.21	8	8.13	8.24	8.06	8	
Max. load per overall length *	kN	40	50	55	65	75	80	90	100	105	115	120	130	140	145	160	
Roller pitch	a	mm	51	51	56	55	54	57	56	55	58	57	59	58	57	60	
	b	mm	73	71	70	70	74	75	78	85	70	76	73	80	91	78	70
Number of cylinders		3	3	4	4	5	5	6	6	7	7	8	8	9	9	10	
Lifting force per cylinder	kN	101.7	101.7	135.6	135.6	169.5	169.5	203.4	203.4	237.3	237.3	271.2	271.2	305.1	305.1	339	
Cylinder capacity	cm <sup>3</sup>	16.8	16.8	22.4	22.4	28	28	33.6	33.6	39.2	39.2	44.8	44.8	50.4	50.4	56	
Cylinder pitch	A	mm	180	230	187	220	190	215	192	212	194	210	195	209	195	208	207
	B	mm	70	70	69	70	70	70	70	70	66	70	65	67	70	66	67
Weight	kg	19	22.8	26.6	30.4	34.2	38	41.8	45.6	49.4	53.2	57	60.8	64.6	68.4	76	
End plate mount screw		4-M10 length 20															

● Max. hydraulic pressure : 24.5MPa ● Lifting force is under hydraulic force at 24.5 MPa. ● Proof pressure : 36.7MPa  
● Operating temperature : 0 ~ 70°C  
\* The value indicates Max. load when all of rollers are in contact with the die.

Die-lifter DLF80

**P** P type stopper

Die-lifter can be inserted/removed.  
(End plate included)

Model designation

**DLF 50 Y 0500 P**

- 1** Die-lifter width \*1
- 2** Y:Standard H:Heavy load
- 3** Die-lifter overall length (mm)  
\*Indicated in 4 digits

\*1 Die-lifter width  
P type stopper is only for DLF28, DLF50.  
It does not correspond to DLF80 (Width 80mm).

**1 2 3** Refer to **pages** → 115 ~ 116

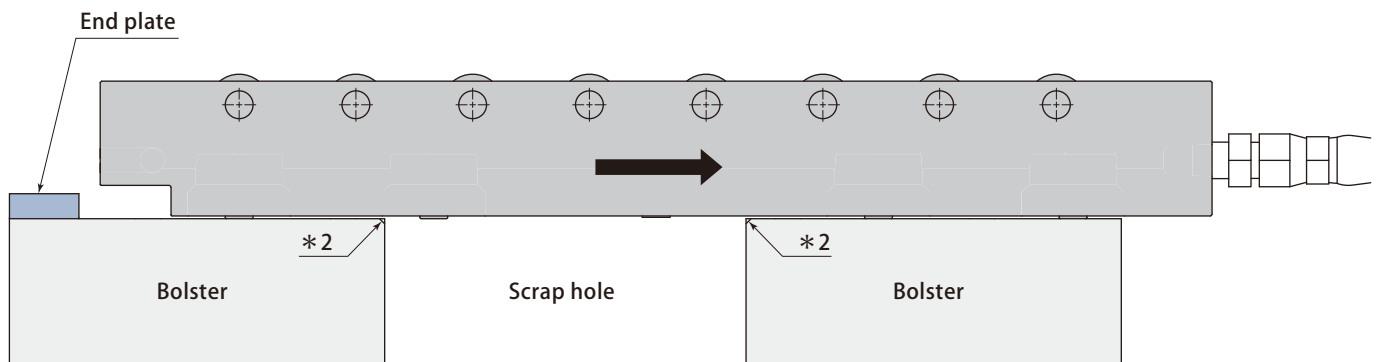
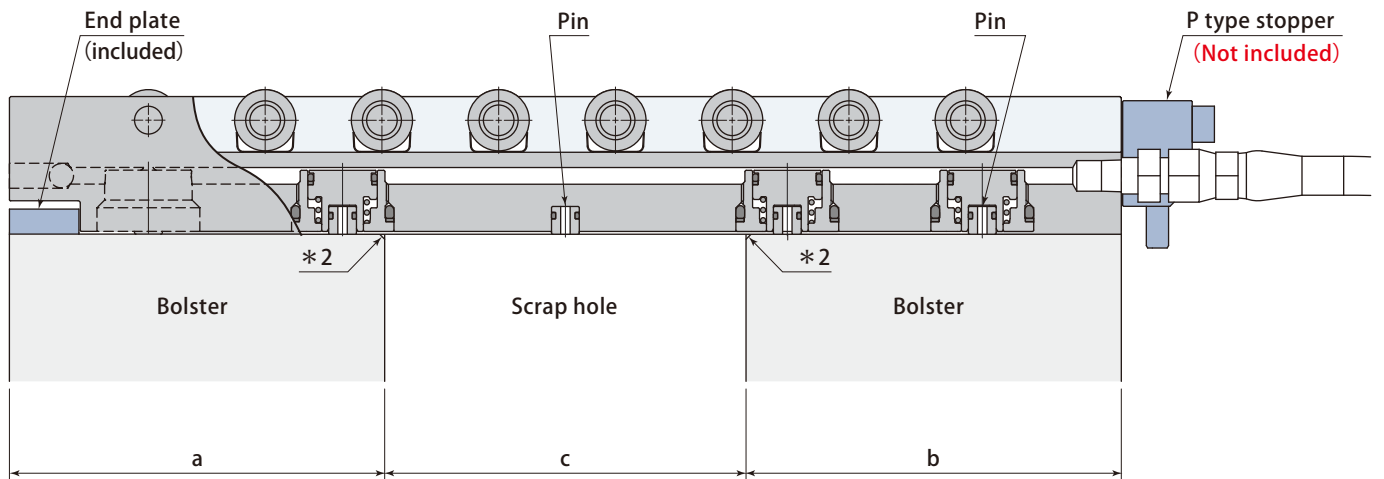

- Indicate scrap hole dimensions a, b and c.
  - When the scrap hole is wide, a pin is provided at center.
  - P type stopper is not included. Order it separately.
  - If Die-lifter is used at T-slot, process T-slot according to Die-lifter.
- \*2 : Chamfer the edge of bolster (C2-C5).

**P type stopper** They are accessories for P type stopper.

Model designation

Lever direction (stopper installed position)

**DLF** - **P** **L** : Lever direction left (Right mounting)  
**R** : Lever direction right (Left mounting)

P type stopper model	DLF-PL / DLF-PR
Stopper mount screw	2-M8 length 35
Spring washer	2-M8

**L** : Lever direction left (Right mounting)

**R** : Lever direction right (Left mounting)

**Locked**

**Locked**

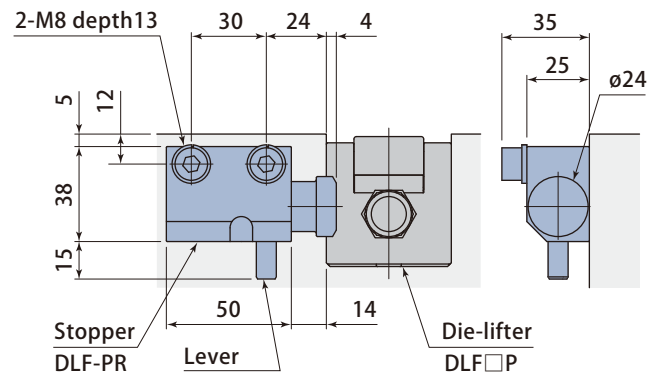
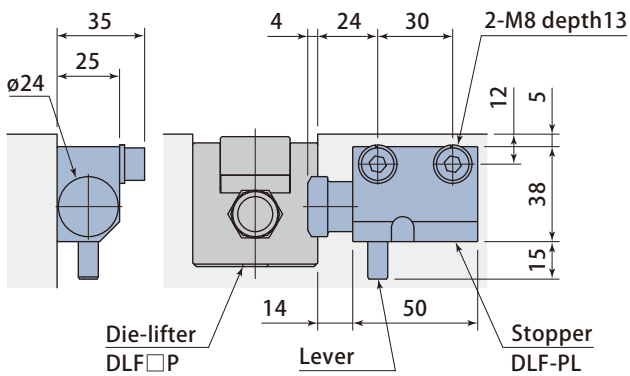

**Unlocked**

**Unlocked**

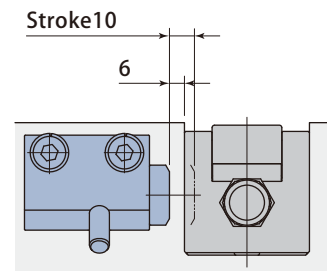
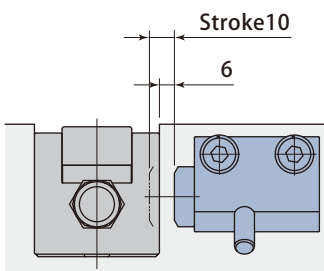

Die-lifter DLF□  
 Scrap hole type

Die-lifter DLF□P Stopper P

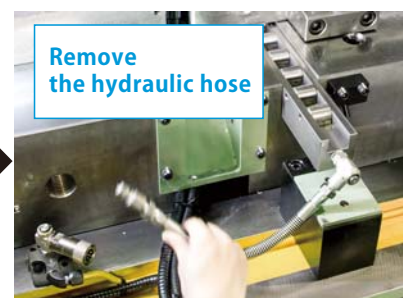
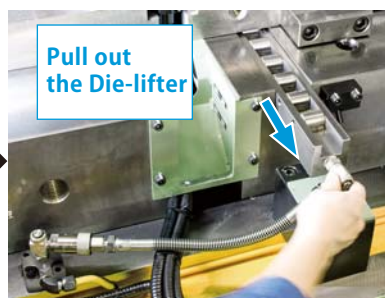
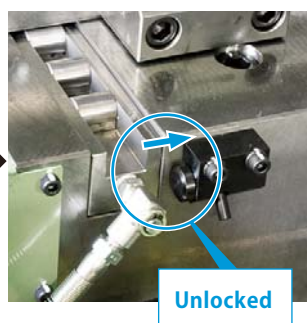
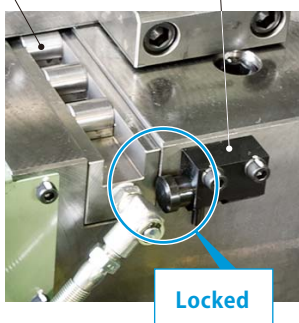

**A** A type stopper

Die-lifter can be inserted/removed.  
(End plate included)

Model designation

**DLF 50 Y 0500 A**

- 1 Die-lifter width \*1
- 2 Y:Standard H:Heavy load
- 3 Die-lifter overall length (mm)  
\* Indicated in 4 digits

\*1 Die-lifter width  
A type stopper is only for DLF28, DLF50.  
It does not correspond to DLF80 (Width 80mm)

1 2 3 Refer to **pages** → 115 ~ 116

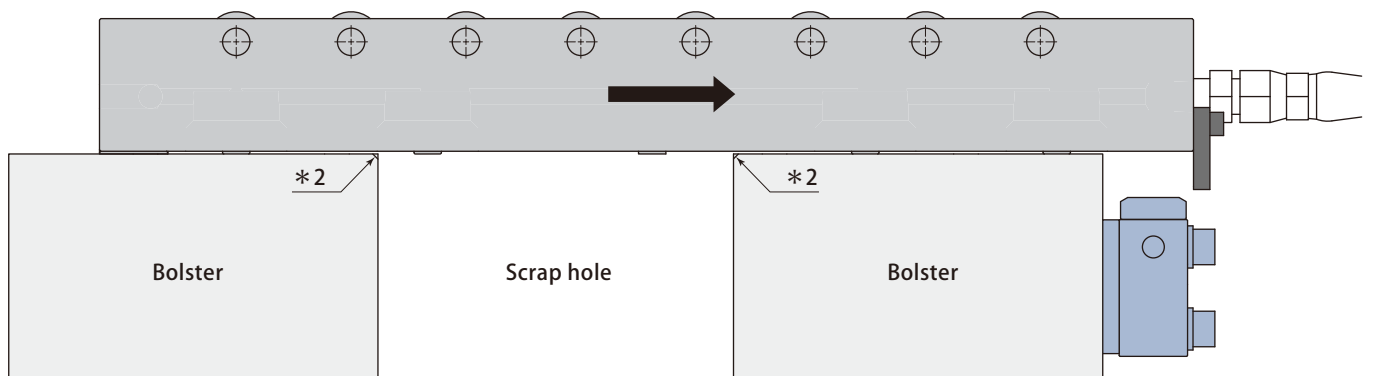
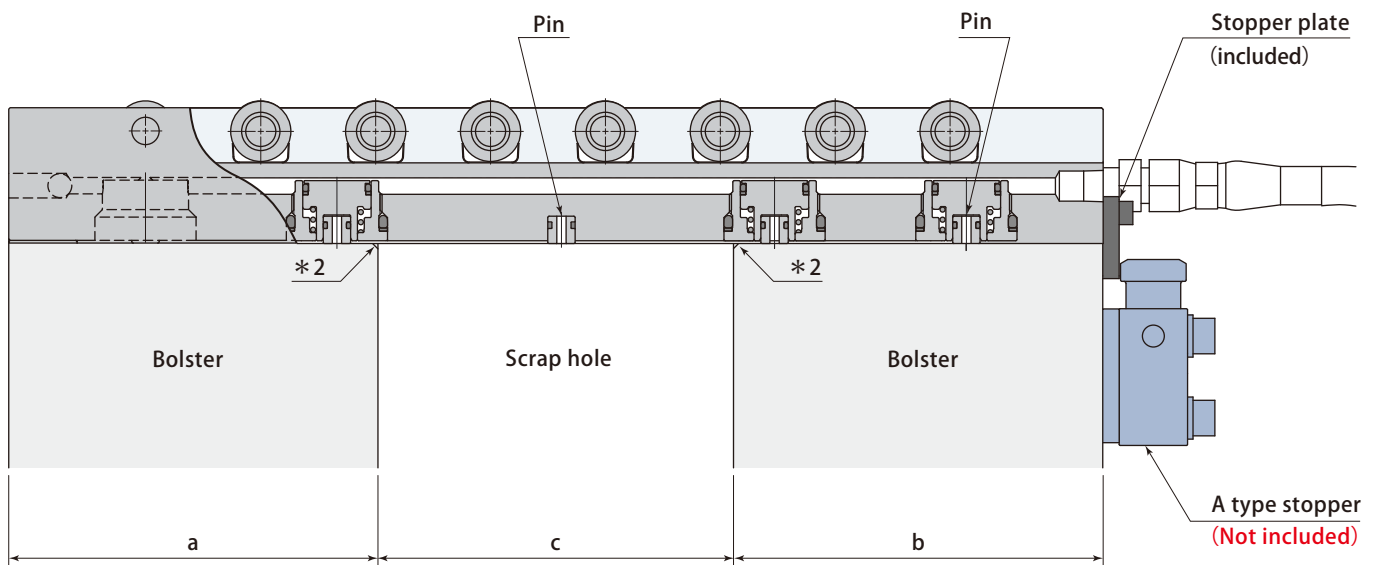

- Indicate scrap hole dimensions a, b and c.
  - When the scrap hole is wide, a pin is provided at center.
  - Include Stopper plate in Pascal Die-lifter.
  - A type stopper is not included. Order it separately.
  - If Die-lifter is used at T-slot, process T-slot according to Die-lifter.
- \*2 : Chamfer the edge of bolster (C2-C5).

Die-lifter DLF  
Scrap hole type

**A type stopper** They are accessories for A type stopper.

Model designation

Lever direction  
**DLF – A** **L** :Lever left side  
**R** :Lever right side

A type stopper model		DLF-AL / DLF-AR	
Die-lifter model		DLF28	DLF50
Lifting stroke		3	3
Plate size	A	26	48
	F	20	30
	C	18	34
	D	5	6
	E	5	11
Slot depth		B	53
Mount detail	G	30	34
	H	17	12
Stopper mount screw		2-M8 length 40	
Spring washer		2-M8	

mm

**Locked**

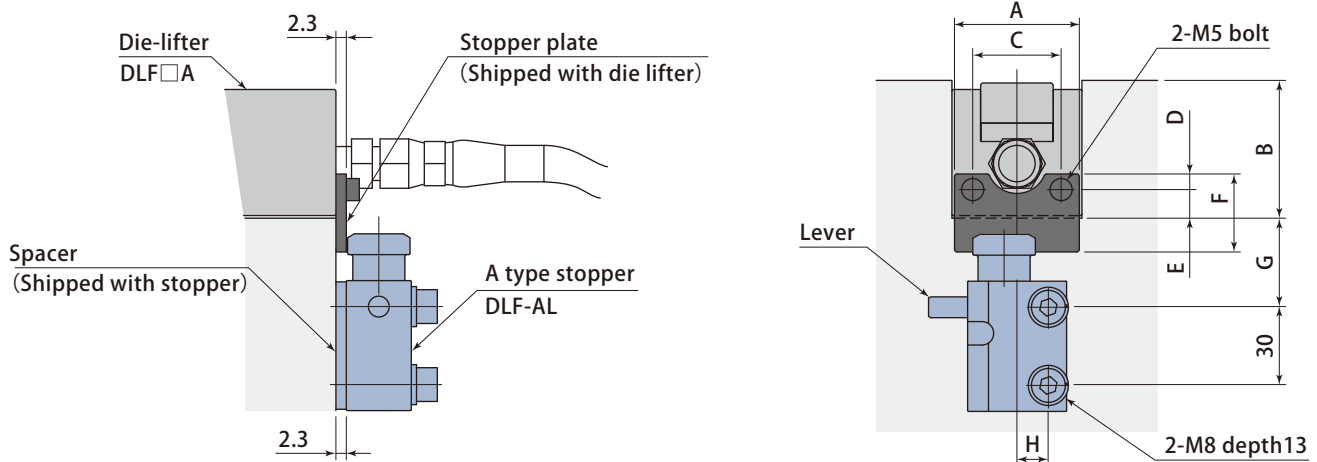

**Unlocked**

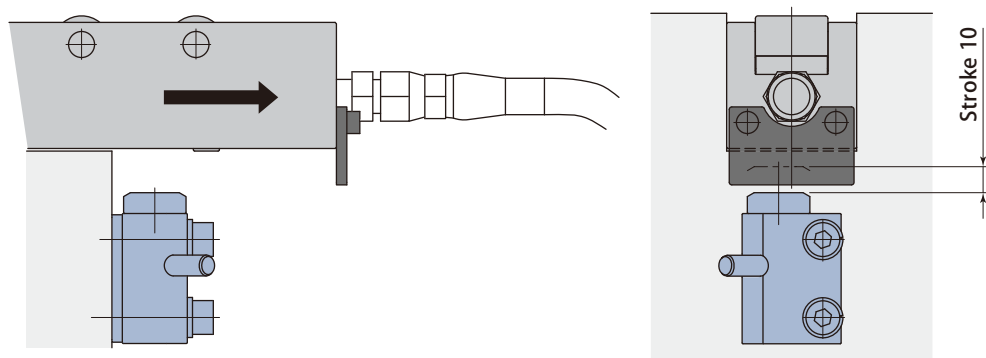

● These drawings indicate : for lever left side **L**

**C** C type key stopper

Two Die-lifters are set up per T-slotted bolster.

Model designation

DLF **50** **H** **0500** **C**

- 1** Die-lifter width \*1
- 2** H: Heavy load \*2
- 3** Die-lifter overall length (mm)  
\* Indicated in 4 digits

- \*1 Die-lifter width  
C type stopper is only for DLF28, DLF50.  
It does not correspond to DLF80(Width 80mm).
- \*2 It does not correspond to the standard Y type.

**1 2 3** Refer to **pages** → 115 ~ 116

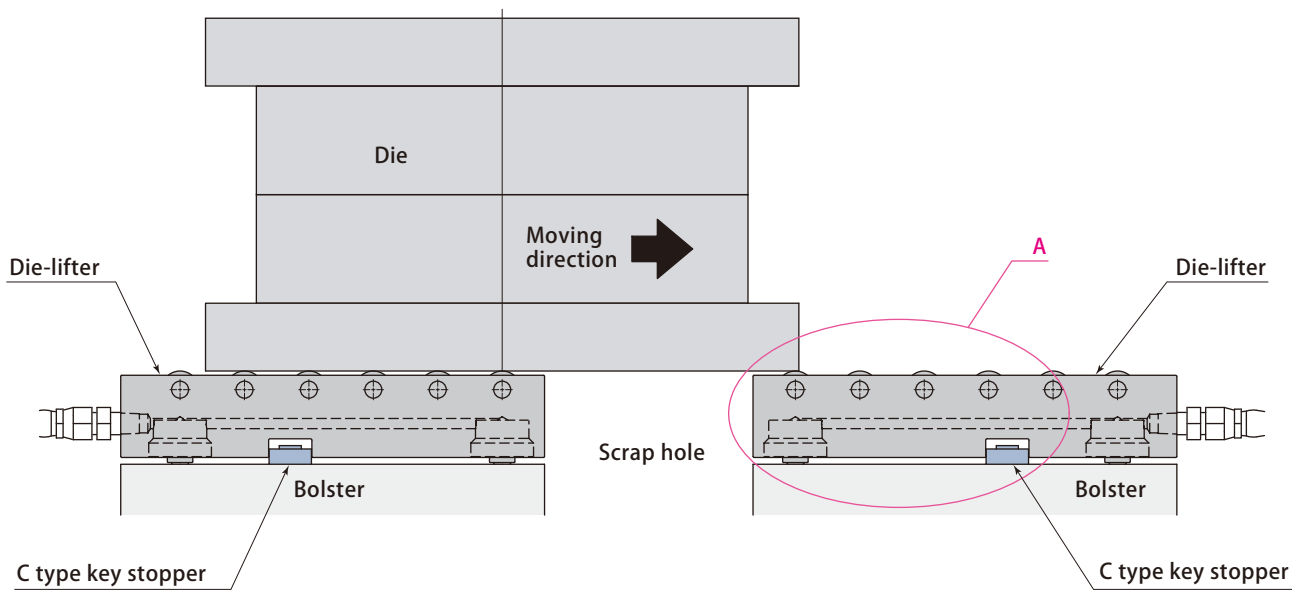

Die-lifter **DLF**  
Scrap hole type

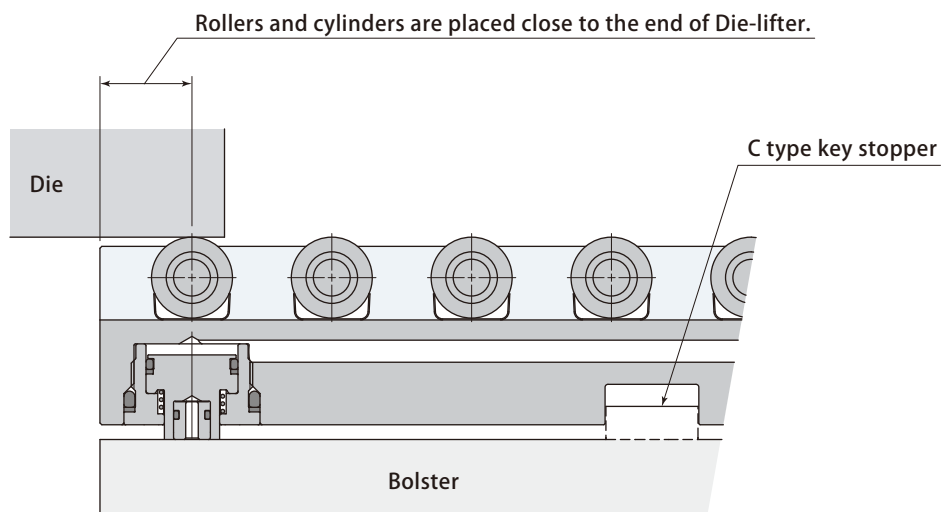

Details:A

- Indicate Die-lifter overall length and die weight.
- Rollers and cylinders are placed close to the end of Die-lifter. Die can be moved smoothly over the scrap hole.
- This model has no Air bleeding valve, loosen pipe fitting for air bleeding.

**Reference specification**

**C type key stopper DLF28H**

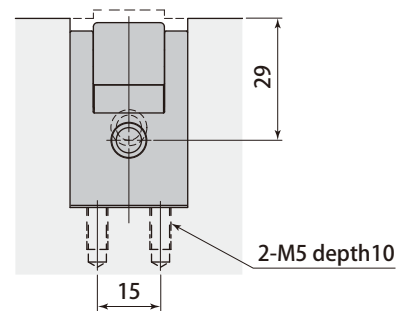
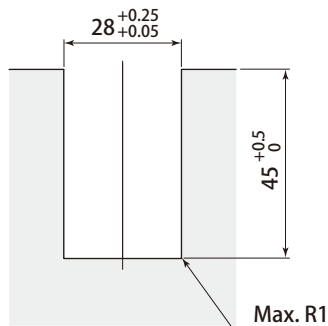
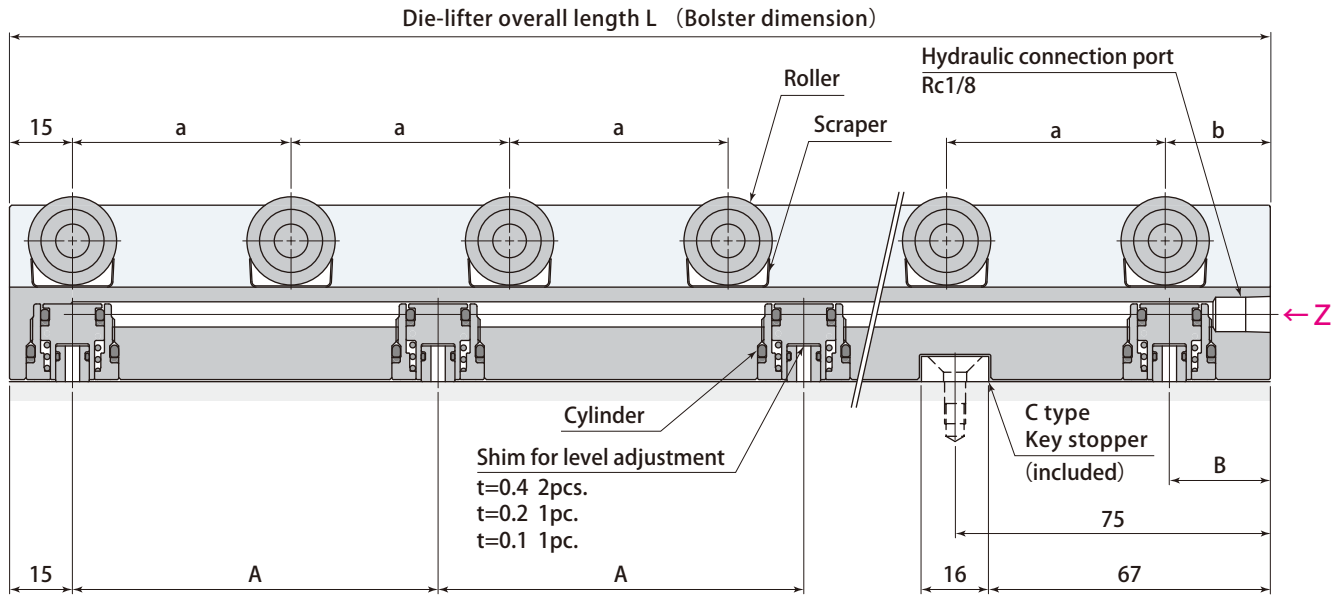

**Slot details**

**VIEW : Z**

Die-lifter overall length L	mm	200	225	250	275	300	325	350	375	400	
Number of rollers		4	4	5	6	6	6	7	8	8	
Max. load per 100 mm	kN	1.96	1.74	1.96	2.14	1.96	1.81	1.96	2.09	1.96	
Max. load per overall length*	kN	3.92	3.92	4.9	5.88	5.88	5.88	6.86	7.84	7.84	
Roller pitch	a	mm	53	61	52	47	52	57	51	47	51
	b	mm	26	27	27	25	25	25	29	31	28
Number of cylinders		2	2	3	4	4	4	4	4	4	
Lifting force per cylinder	kN	8.9	8.9	13.4	17.8	17.8	17.8	17.8	17.8	17.8	
Cylinder capacity	cm <sup>3</sup>	1.08	1.08	1.62	2.16	2.16	2.16	2.16	2.16	2.16	
Cylinder pitch	A	mm	160	185	105	78.5	87	95	103.5	112	120
	B	mm	25	25	25	24.5	24	25	24.5	24	25
Weight	kg	1.4	1.6	1.8	1.9	2.1	2.3	2.5	2.6	2.8	
Key stopper mount screw		2-M5 length10									

● Max. hydraulic pressure : 24.5 MPa ● Lifting force is under hydraulic force at 24.5 MPa. ● Proof pressure : 36.7 MPa

● Operating temperature : 0 ~ 70 °C

\* The value indicates Max. load when all of rollers are in contact with the die.



**Reference specification**

**C type key stopper DLF50H**

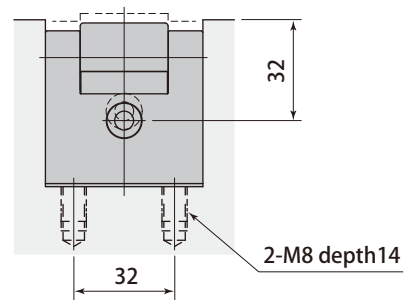
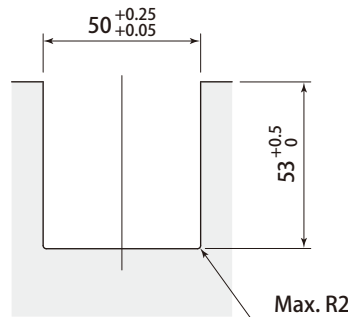
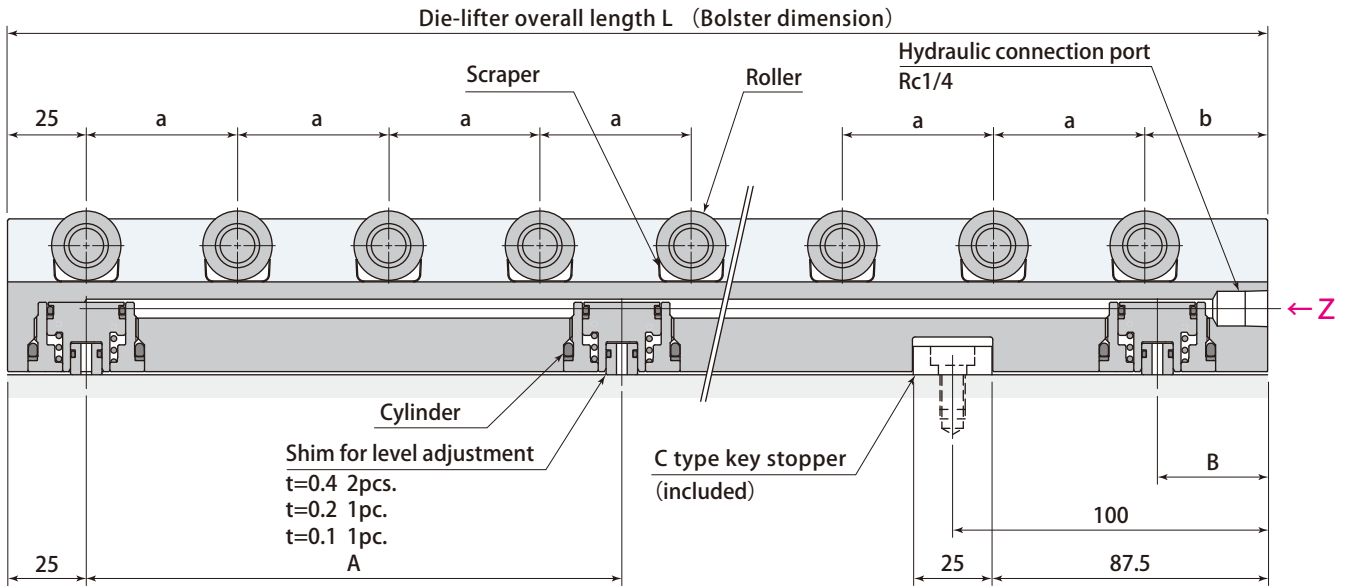

**Slot details**

**VIEW : Z**

Die-lifter overall length L	mm	200	225	250	275	300	325	350	375	400
Number of rollers		5	5	6	6	6	7	8	8	8
Max. load per 100 mm	kN	4.65	4.13	4.46	4.06	3.72	4.01	4.25	3.97	3.72
Max. load per overall length *	kN	9.3	9.3	11.2	11.2	11.2	13	14.9	14.9	14.9
Roller pitch	a	mm	35	41	38	43	48	44	45	48
	b	mm	35	36	35	35	35	36	35	39
Number of cylinders		2	2	2	3	3	3	3	3	3
Lifting force per cylinder	kN	24	24	24	36	36	36	36	36	36
Cylinder capacity	cm <sup>3</sup>	3	3	3	4.5	4.5	4.5	4.5	4.5	4.5
Cylinder pitch	A	mm	140	165	190	108	120	133	158	170
	B	mm	35	35	35	34	35	34	35	35
Weight	kg	3.2	3.6	4	4.4	4.8	5.2	5.6	6	6.4
Key stopper mount screw		2-M8 length14								

● Max. hydraulic pressure : 24.5 MPa ● Lifting force is under hydraulic force at 24.5 MPa. ● Proof pressure : 36.7 MPa

● Operating temperature : 0 ~ 70°C

\* The value indicates Max. load when all of rollers are in contact with the die.

Die-lifter DLF  
Scrap hole type

Die-lifter **DLF**   
Scrap hole type

**Long lifting stroke type**

Model designation

**DLF** 50 Y 0500 — Drawing No.

- 1** Die-lifter width
  - 2** Y: Standard H: Heavy load
  - 3** Die-lifter overall length (mm)  
\* Indicated in 4 digits
- For the long lift specifications, drawing No. is added at the end of model No.
- 1 2 3** Refer to pages → 115 ~ 116

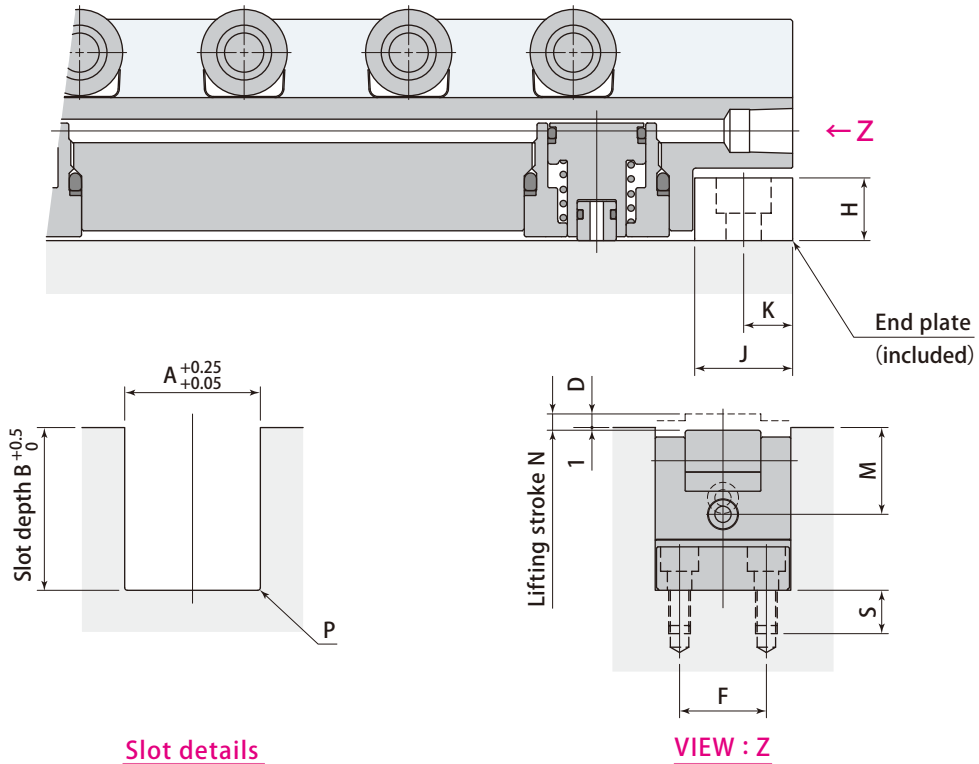

Slot details

VIEW : Z

**2-oil connection port is provided when the overall length is 1000mm and over and lift stroke at 12mm and over .**

- 2-oil connection port is provided when the overall length is 1000mm and over and lift stroke at 12mm and over in order to have the lifter up and down evenly.
- Provide flow controls valve for each port as shown in circuit diagram to have the lifter up and down evenly by controlling the speed. The valve to be prepared by the customer.
- Below model is recommended when the flow control valve is prepared by the customer.

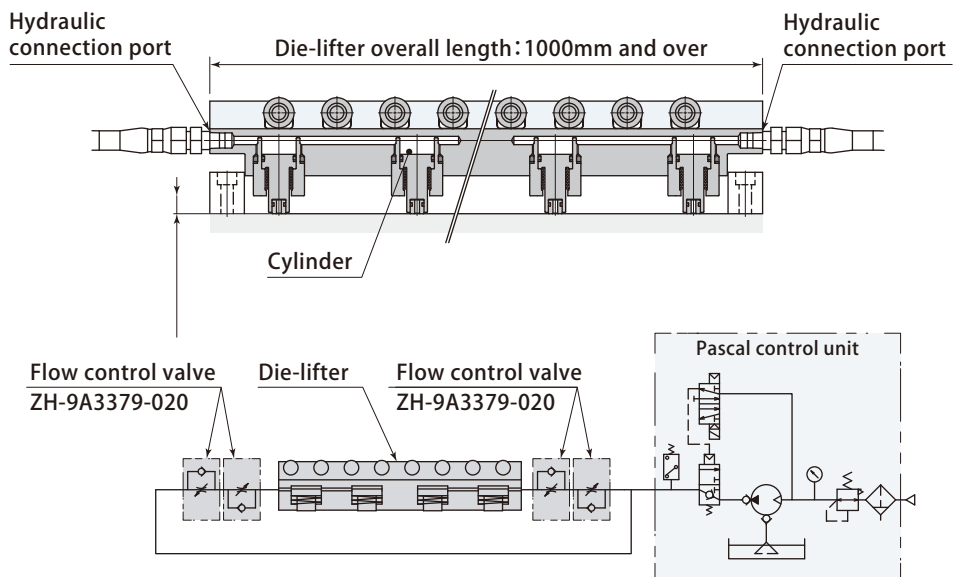

Sample: Die-lifter circuit diagram with flow control valve

Manufacturer name : Hirose Valve Industry Co., Ltd.  
Product Name : Throttle Check Valve  
Model : HT - 728 - 02

Die-lifter DLF  
Long lifting stroke type

● DLF28 Long lifting stroke type Lifting stroke 6 ~ 16 mm

Lifting stroke	N	3 (Standard)	6	8	12	16
Slot depth	B	45	52	56	64	73
Roller-level	D	2	5	7	11	15
End plate thickness	H	6	12	19	25	36
End plate mount screw		4-M6 length 10	4-M6 length 16	4-M6 length 22	4-M6 length 30	4-M6 length 35
Thread hole depth	S	10				
	K	8				
	J	16				
	A	28				
	P	Max.R1				
	M	29				
	F	15				

● DLF50 Long lifting stroke type Lifting stroke 6 ~ 20 mm

Lifting stroke	N	3 (Standard)	6	8	10	12	16	20
Slot depth	B	53	60	64	73	73	80	89
Roller-level	D	2	5	7	9	11	15	19
End plate thickness	H	9	16	19	30	30	38	38
End plate mount screw		4-M8 length14	4-M8 length20	4-M8 length25	4-M8 length30	4-M8 length30	4-M8 length40	4-M8 length40
Thread hole depth	S	14						
	K	12.5						
	J	25						
	A	50						
	P	Max.R2						
	M	32						
	F	32						

● DLF80 Long lifting stroke type Lifting stroke 6 ~ 16 mm

Lifting stroke	N	4 (Standard)	6	12	16
Slot depth	B	80	85	96	109
Roller-level	D	3	5	11	15
End plate thickness	H	16	25	25	45
End plate mount screw		4-M10 length 20	4-M10 length 30	4-M10 length 30	4-M10 length 50
Thread hole depth	S	18			
	K	12.5			
	J	25			
	A	80			
	P	Max.R2			
	M	49			
	F	50			

- If overall length is 1000mm and over, and lifting stroke is 12mm and over, 2 ports piping is applied.
- The cover will be mounted on model DLF with long lifting stroke. DLF50 : 20mm and over , DLF28 : 16mm and over refer to **page→133**.
- Pre-roller is special specifications for aligning the level between Die-lifter and rollers.
- Choose long stroke for Clamp. When Clamp with standard stroke is used, be sure to lift up Die-lifter after Clamp is moved backward.

Model designation

DLF 50 Y 0500 — Drawing No.

- 1 Die-lifter width
  - 2 Y: Standard H: Heavy load
  - 3 Die-lifter overall length (mm)  
\* Indicated in 4 digits
- 1 2 3 Refer to pages → 115 ~ 116
- For roller cover type, Heat proof type, Special cylinder position and Special number of rollers, the drawing No. is added at the end of model No.

**Roller cover** Cover is attached on the upper surface of Die-lifter and it prevents scrap intrusion to the rollers.

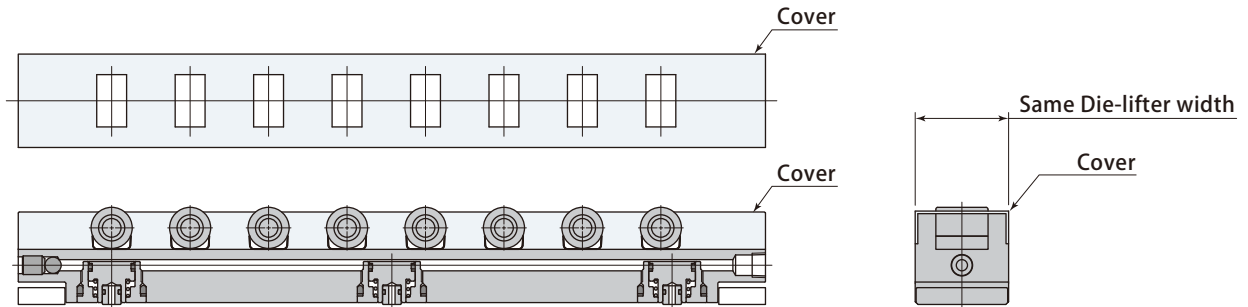

- The cover shall be equipped with the DLF for the following model and stroke.  
DLF50: stroke more than 20mm  
DLF28: stroke more than 16mm

**Heat proof type** It is applied under condition that the die and its surroundings are in high temperature.

- The operating temperature of heat proof type is 5-120°C.

**Special cylinder position**

In case that Die-lifter shot has cushion pin hole, the cylinder positioning shall be special.

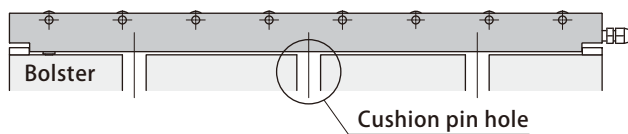

- Indicate the shape and size of bolster. Contact Pascal for the details.

**Special number of rollers**

In case that the die has cutouts, number of rollers shall be special.

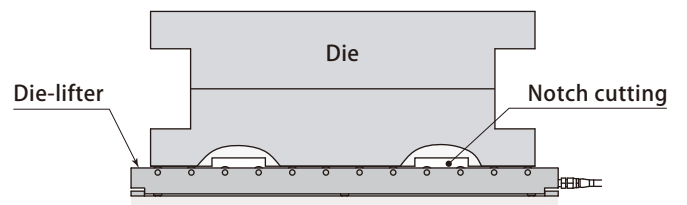

- Indicate the shape and size of the bottom surface of die. Contact Pascal for the details.

