

# Slide lock system

model **SLA**

*For safety  
maintenance*



**Pascal**  
[www.pascaleng.co.jp](http://www.pascaleng.co.jp)

PASCAL Slide lock system has been particularly designed for a stamping machine and die. It is the essential device for safety maintenance works. Securely locking the press slide at the random position between T.D.C. and B.D.C., Slide lock system prevents a physical injury to people or damage to dies.

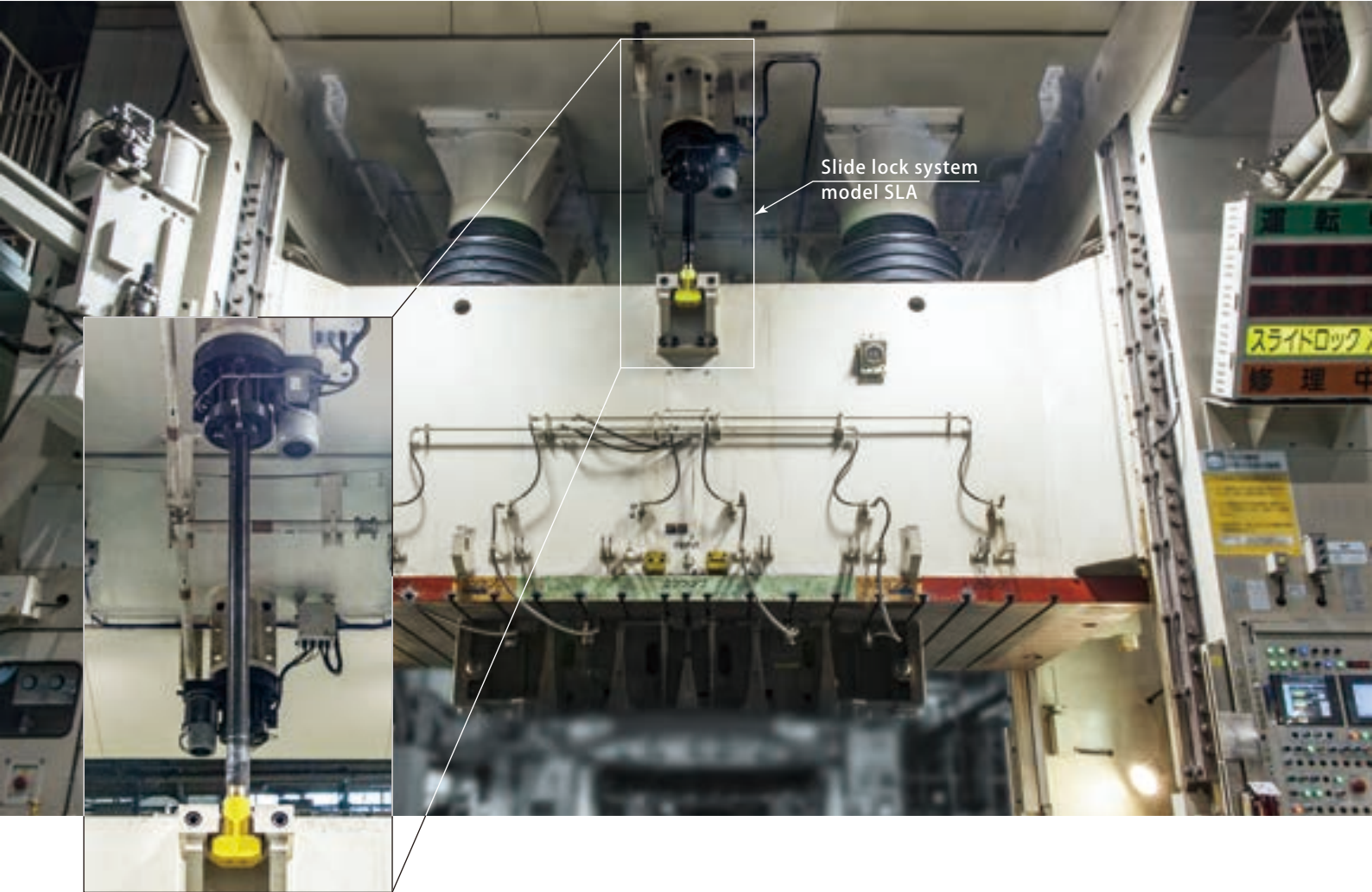

① Unlocked

(While machine is in operation for production)

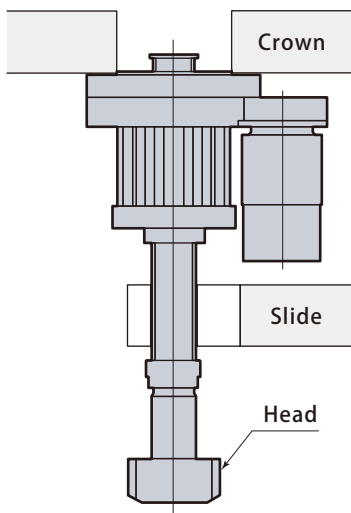

② Rotating & ascending

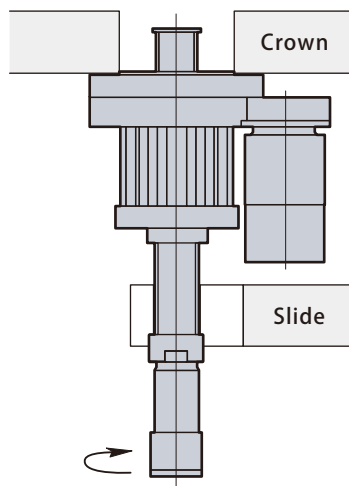

Screw head rotates 90° as soon as the screw rod starts ascending.

③ Locked

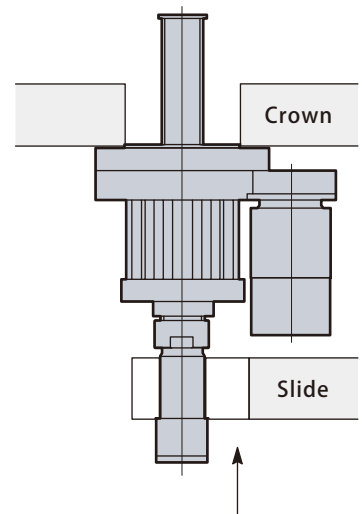

Head automatically stops ascending when it touches the bottom of slide.

Model designation

SLA **32** - **0200** - **0630** **C**

1 Holding capacity

SLA32 : 314kN  
 SLA50 : 490kN  
 SLA80 : 784kN

2 SLA32, 50 : -  
 SLA80 : A

3 Lock stroke

4 Distance to the slide at T.D.C with position upper limit

5 Direction of head

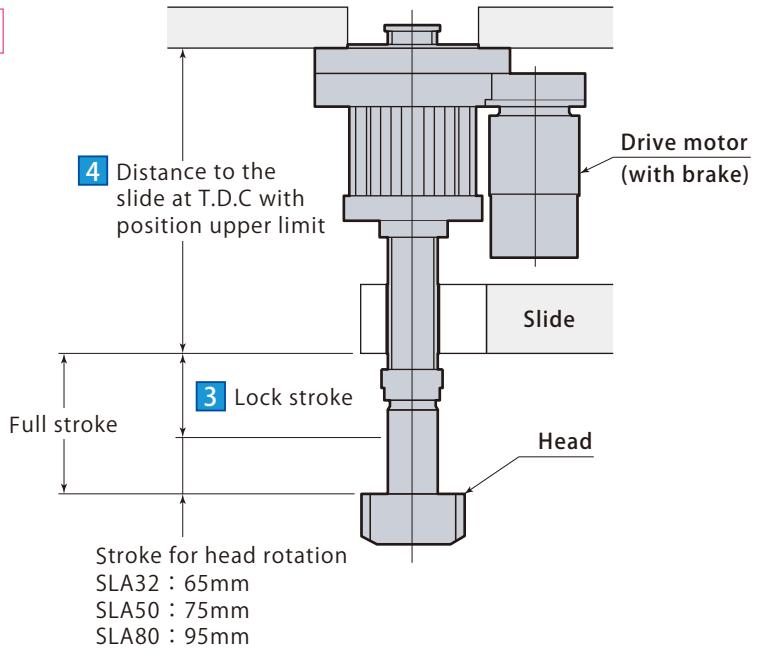

Specifications

Model		SLA32	SLA50	SLA80
Holding capacity (allowable load)	kN	314	490	784
Full stroke	mm	Lock stroke + 65	Lock stroke + 75	Lock stroke + 95
Max. ( 3 + 4 )	mm	2800		3000
Traveling speed	mm/s	85 (50Hz) , 105 (60Hz)		75 (50Hz) , 95 (60Hz)
Drive motor * (with brake)	kW	0.75	1.5	
Operating temperature	°C	0 ~ 50		
Weight	kg	$0.025 \times ( 3 + 4 ) + 120$	$0.04 \times ( 3 + 4 ) + 180$	$0.06 \times ( 3 + 4 ) + 260$

\* Ask Pascal for motor voltage.

5 Direction of screw head and type

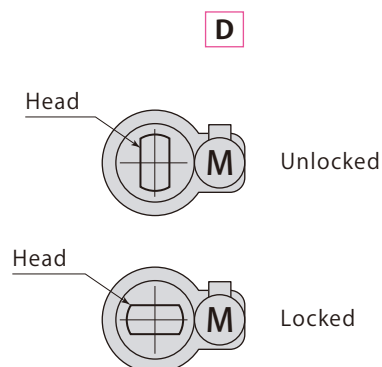
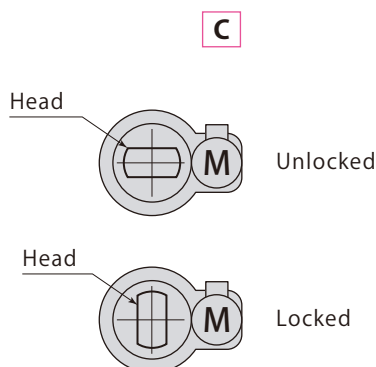

Structure

The unique hydraulic cushion device ensures smooth and reliable lock/unlock operation.

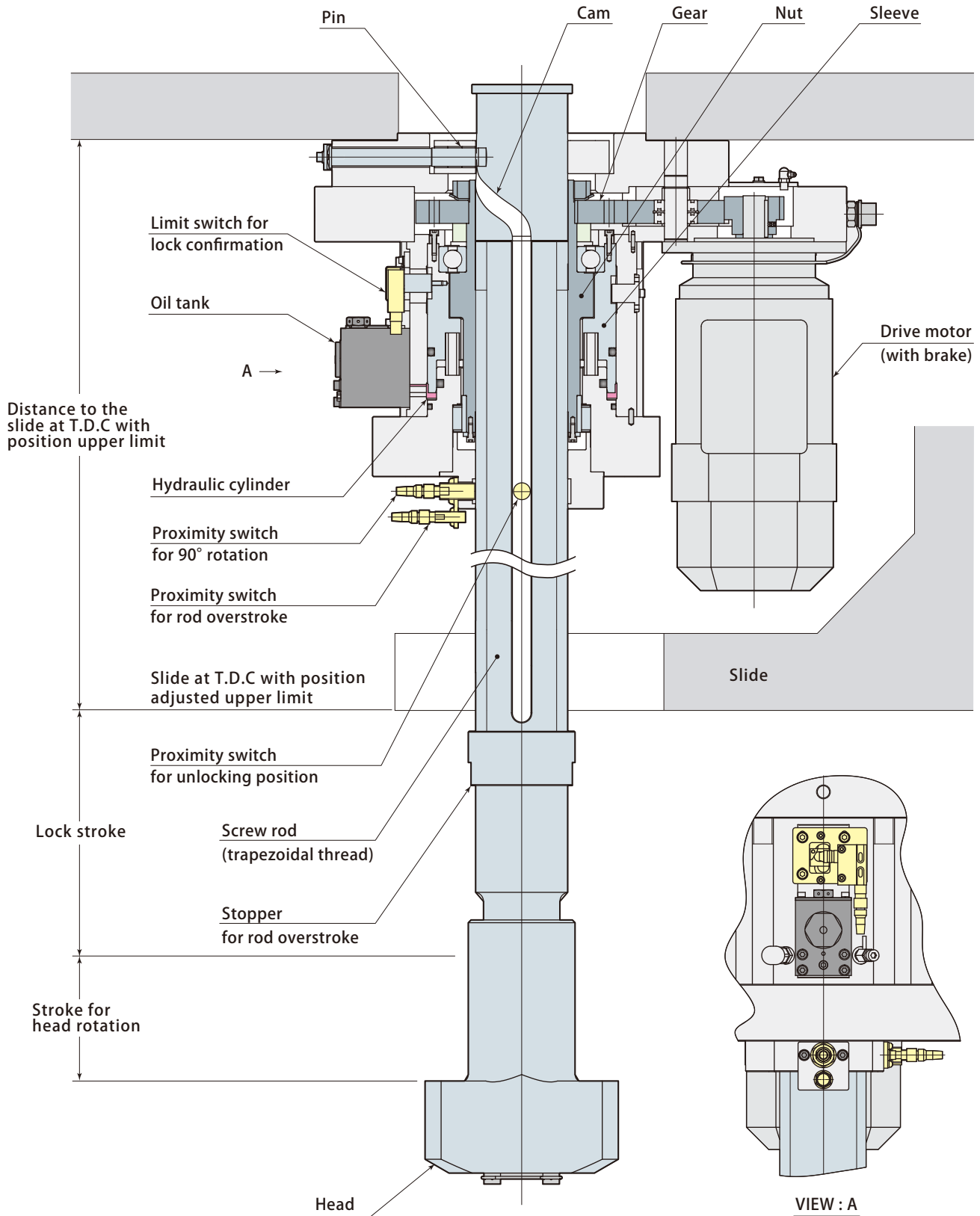



Dimensions

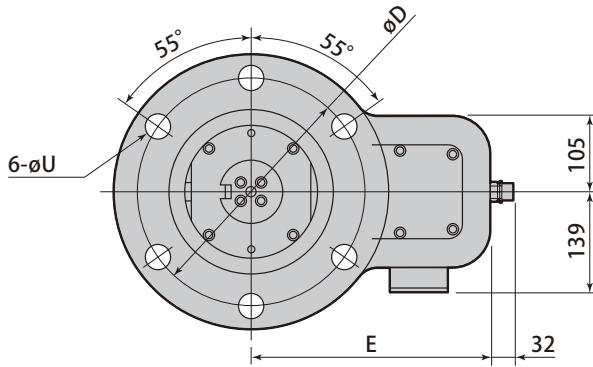

VIEW : A (SLA50/SLA80)

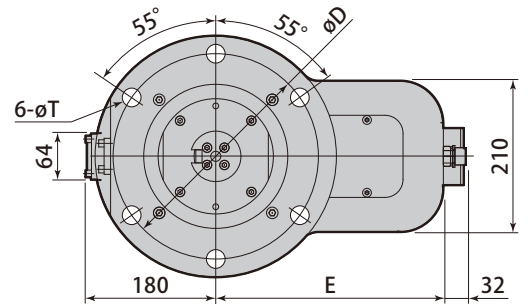

VIEW : A (SLA32)

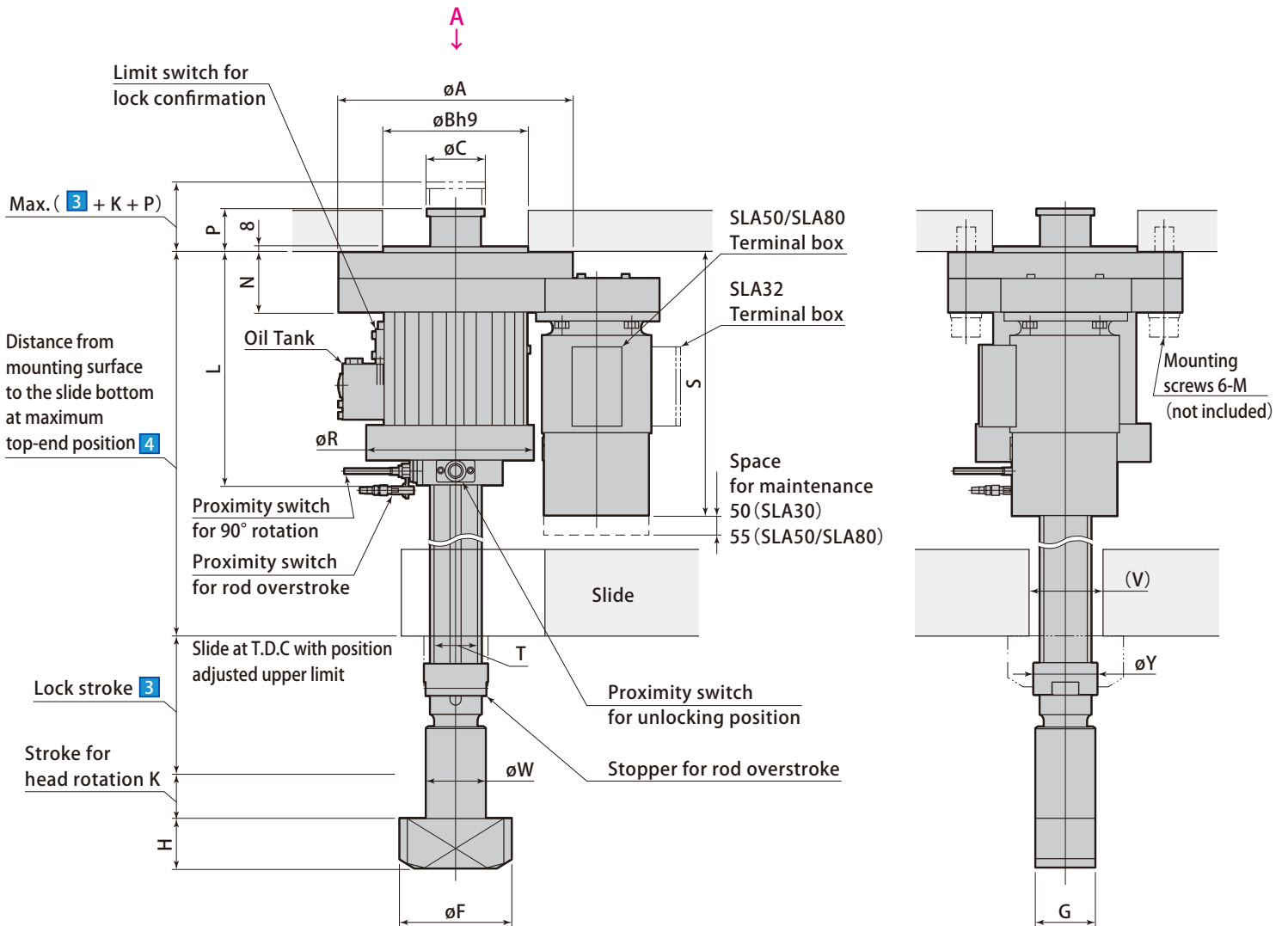

Dimensions

mm

Model	SLA32	SLA50	SLA80
øA	335	380	450
øB	200	230	270
øC	70	90	110
øD	285	320	380
E	316	332	353
øF	170	190	210
G	80	100	120
H	60	80	100
Stroke for head rotation K	65	75	95
<b>4</b>	Min. 600	Min. 600	Min. 630
Max. ( <b>3</b> + <b>4</b> )	2800	2800	3000
L	361	376	400
M	M24	M30	M36
N	95	100	110
P	53	63	61
øR	252	282	324
S (reference value) *	448	479	489
Trapezoidal thread T	Tr 60 × 9	Tr 80 × 10	Tr 100 × 12
øU	26	32	40
V	100	120	140
øW	79	99	100
øY	78	99	119

\* Varies depending on motor specifications.

# Pascal

Itami, Hyogo, Japan 664-8502  
TEL. +81-72-777-3333 FAX. +81-72-777-3520

---

Chicago, U.S.A.	TEL. +1-847-427-1234
Stuttgart, Germany	TEL. +49-711-782-850-0
Dalian, China	TEL. +86-411-8732-2988
Shanghai, China	TEL. +86-21-5263-4122
Changwon, Korea	TEL. +82-55-274-0971
Bangkok, Thailand	TEL. +66-2173-5855

---

