

New model with improved Die stopper for Pre-roller  
 New models to be produced starting from December 2011 orders.

### New Model

- **Height of Die stopper Increased**

To improve the safety of die exchange, the die stopper height has been changed from 5mm to 10mm.

- **Elimination of Die Stopper Lever**

With the old model, the Die Stopper could be lowered by using the lever. This lever was eliminated with our new model so that the stopper is not able to remain in the lowered position. Like the old model, when the die is lowered onto the Stopper, the Stopper will lower and prevents damage to the underside of the die.

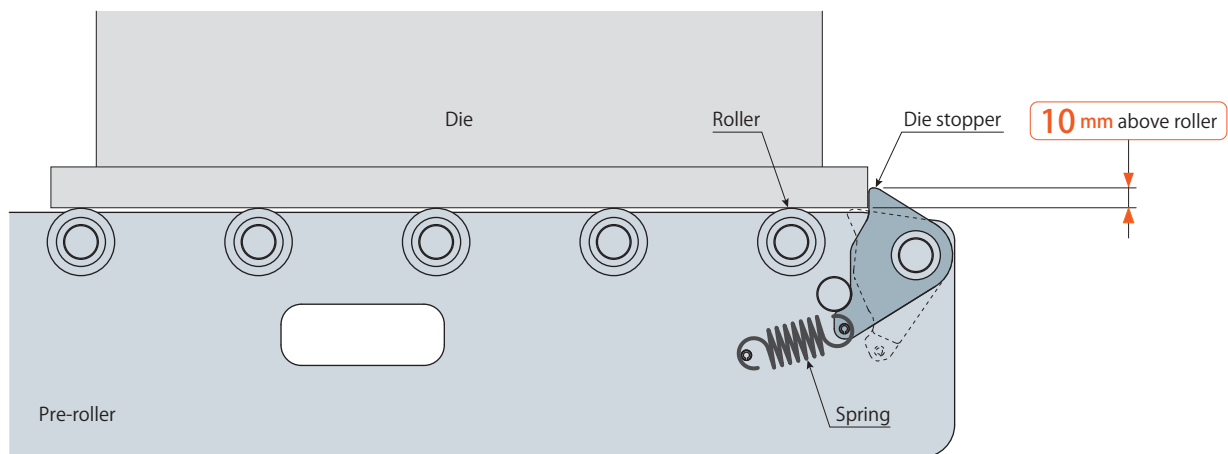

### Old Model

#### Die stopper raised

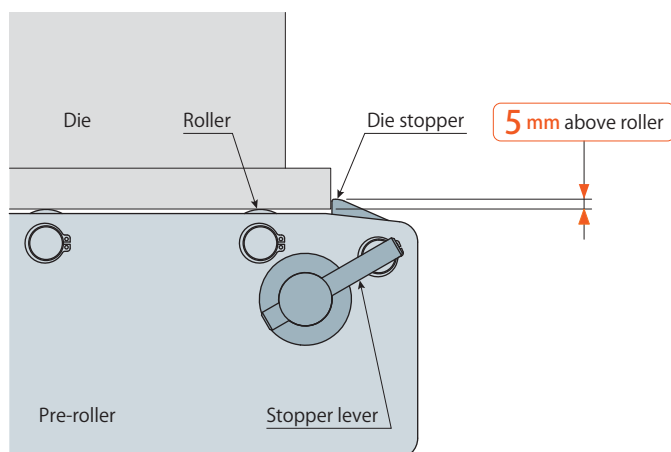

#### Die stopper lowered

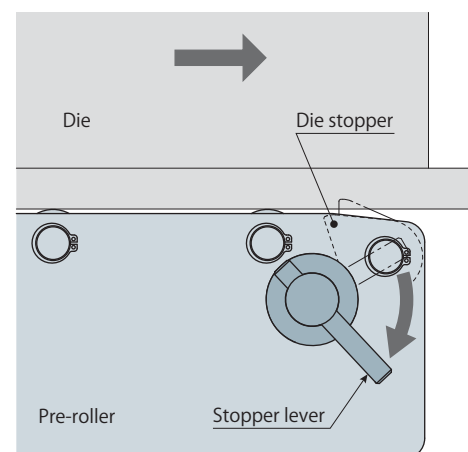

The stopper lever is commonly used to transfer the die onto delivery trucks (or similar), but has been eliminated for safety reasons with this modification.