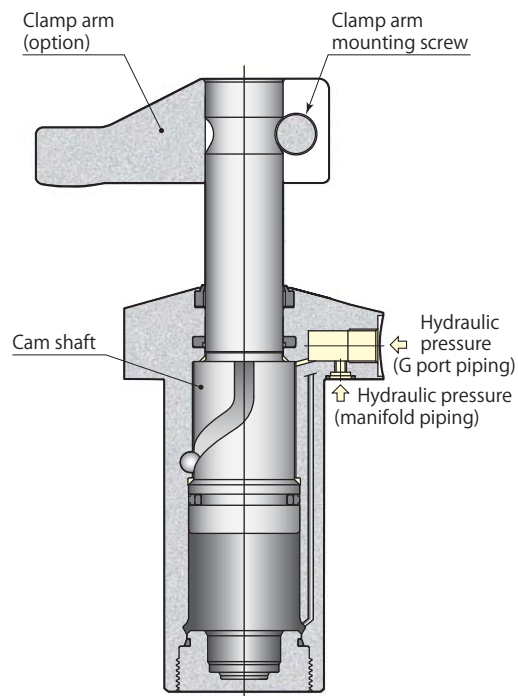
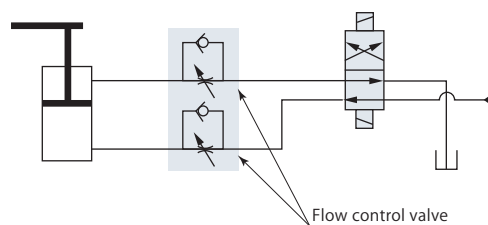

Upper flange

model CTW□U-□

Hydraulic circuit diagram

For flow control valve, we recommend the meter-in control. If meter-out control is used, due to the area difference, it will cause back pressure and become high pressure. This can lead to malfunction of the system. Please be aware when designing the circuit.

Flow control valve model VCH can not be mounted.

Specifications page → 51

Upper flange page → 54

Lower flange page → 58

Swing angle 30°, 45°, 60° page → 62

Specifications

Size	Mounting and piping types	Swing direction (when clamping), swing angle
CTW 06 10 16 25	U : Upper flange	L : Counter-clockwise, swing angle 90°
		LN30 : Counter-clockwise, swing angle 30°
	B : Lower flange	LN45 : Counter-clockwise, swing angle 45°
		LN60 : Counter-clockwise, swing angle 60°
		R : Clockwise, swing angle 90°
		RN30 : Clockwise, swing angle 30°
		RN45 : Clockwise, swing angle 45°
		RN60 : Clockwise, swing angle 60°
		C : Straight, swing angle 0°

■ indicates made to order.

Mounting and piping types

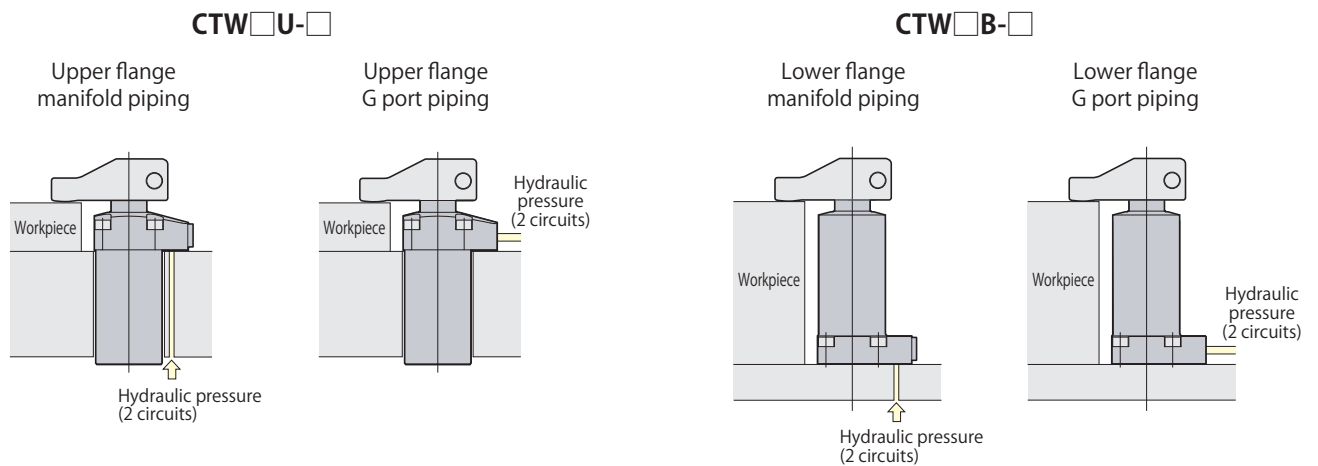

Swing direction (when clamping)

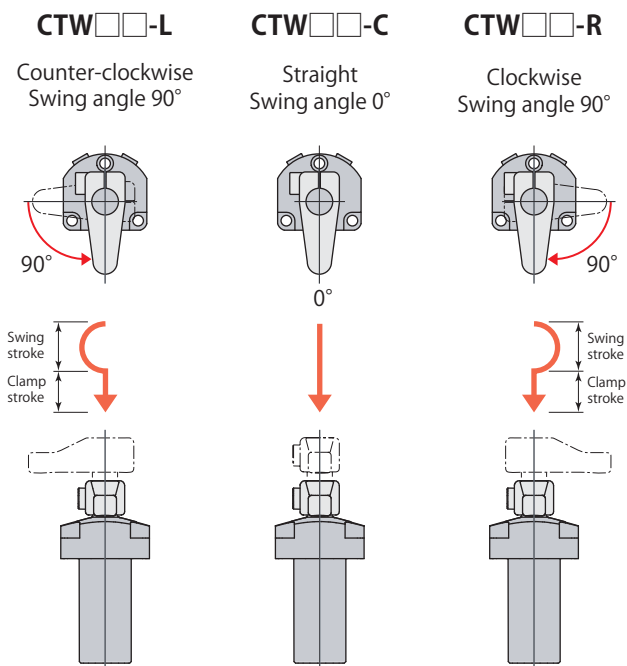

Swing angle

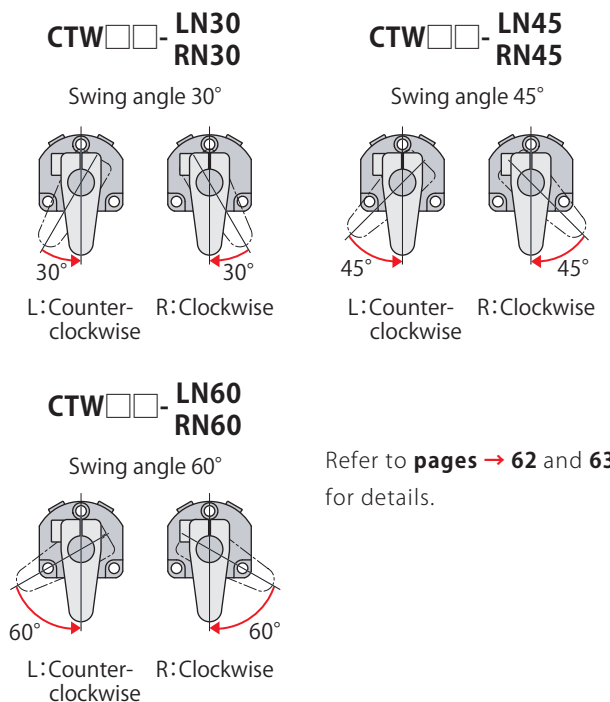

Specifications

Model			CTW06	CTW10	CTW16	CTW25
Cylinder force (hydraulic pressure 35MPa)		kN	6.3	14.3	19.2	26.3
Clamping force*1	Hydraulic pressure 35MPa	kN	5.4	12.4	16.6	22.9
	Hydraulic pressure 25MPa	kN	3.9	8.8	11.9	16.3
	Hydraulic pressure 15MPa	kN	2.3	5.3	7.1	9.8
Standard clamp arm length		mm	40	50	57	65
Cylinder inner diameter		mm	22	32	40	44.5
Rod diameter		mm	16	22.4	30	32
Effective area (clamp)		cm ²	1.79	4.10	5.50	7.51
Swing angle	CTW□□-L, R		90° ± 3°			
	CTW□□-C		0°			
Repeated clamp positioning accuracy			±0.5°			
Full stroke		mm	22	28	32	40
90° swing stroke (CTW□□-L, R)		mm	12	15	18	24
Clamp stroke (CTW□□-L, R)		mm	10	13	14	16
Max. swing torque*2		N·m	0.35	0.97	1.51	2.10
Max. oil flow rate	Clamp	L/min	0.43	1.23	1.48	2.70
	Unclamp	L/min	0.91	2.41	3.39	5.60
Cylinder capacity	Clamp	cm ³	3.9	11.5	17.6	30.0
	Unclamp	cm ³	8.4	22.5	40.2	62.2
Recommended tightening torque of mounting screws*3		N·m	12	29	29	29

- Pressure range: 3.5–35 MPa
- Proof pressure: 52.5 MPa
- Operating temperature: 0–70 °C
- Fluid used: General mineral based hydraulic oil (ISO-VG32 equivalent)
- Seals are resistant to chlorine-based cutting fluid. (not thermal resistant specification)

*1: Clamping force at time standard clamp arm is mounted (refer to section on W1, W2 series on [page → 78](#)).
Clamping force varies depending on clamp arm length. Refer to performance table ([page → 53](#)) for details.

*2: This is the limit value for lifting arm at 3.5 MPa when mounted vertically.

*3: ISO R898 class 12.9

Manifold piping and G port piping are available.Manifold piping

Remove sealing plugs when using manifold piping. An air bleeding valve (model VCE) is mountable on the G port of the clamp.

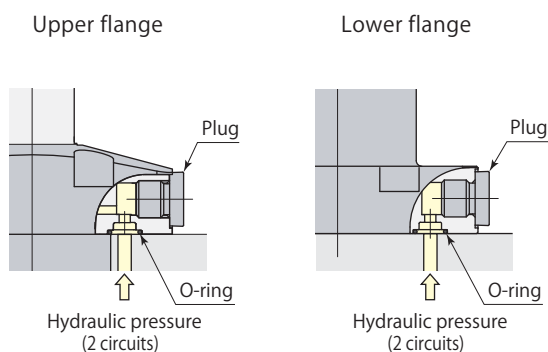
G port piping

Remove plugs and O-ring when choosing G port piping. The flow control valve and the air bleeding valve should be installed in the middle of oil path.

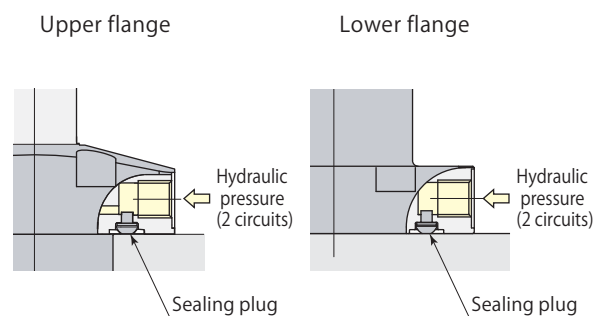

Performance table

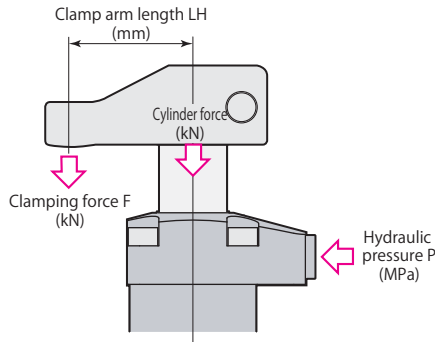

Clamping force varies depending on the clamp arm length (LH) and hydraulic pressure (P).

Clamping force calculation formula

$$F = P / (\text{Coefficient 1} + \text{Coefficient 2} \times LH)$$

F: Clamping force P: Hydraulic pressure LH: Clamp arm length

CTW10 with clamp arm length (LH) = 60 mm at hydraulic pressure of 20 MPa, Clamping force F is calculated by $20 / (2.44 + 0.00773 \times 60) = 6.9$ kN

Do not use the clamp in the nonusable range. It may cause damage to the cylinder and rod.

model CTW06		Clamping force $F = P / (5.58 + 0.0224 \times LH)$					
Hydraulic pressure MPa	Cylinder force kN	Clamping force kN					Max. arm length Max. LH mm
		Clamp arm length LH mm					
		40	60	80	100	120	
35	6.3	5.4					42
30	5.4	4.6					51
25	4.5	3.9	3.6	Nonusable range			64
20	3.6	3.1	2.9	2.7			85
15	2.7	2.3	2.2	2.0	1.9	1.8	127
10	1.8	1.5	1.4	1.4	1.3	1.2	200
5	0.9	0.8	0.7	0.7	0.6	0.6	↑
3.5	0.6	0.5	0.5	0.5	0.4	0.4	200

model CTW10		Clamping force $F = P / (2.44 + 0.00773 \times LH)$					
Hydraulic pressure MPa	Cylinder force kN	Clamping force kN					Max. arm length Max. LH mm
		Clamp arm length LH mm					
		50	60	80	100	120	
35	14.3	12.4					52
30	12.3	10.6	10.3	Nonusable range			62
25	10.2	8.8	8.6	Nonusable range			77
20	8.2	7.1	6.9	6.5	6.2		103
15	6.1	5.3	5.2	4.9	4.7	4.5	154
10	4.1	3.5	3.4	3.3	3.1	3.0	240
5	2.0	1.8	1.7	1.6	1.6	1.5	↑
3.5	1.4	1.2	1.2	1.1	1.1	1.0	240

model CTW16		Clamping force $F = P / (1.82 + 0.00506 \times LH)$					
Hydraulic pressure MPa	Cylinder force kN	Clamping force kN					Max. arm length Max. LH mm
		Clamp arm length LH mm					
		57	80	100	120	140	
35	19.2	16.6					57
30	16.5	14.2					62
25	13.7	11.9	Nonusable range				77
20	11.0	9.5	9.0	8.6			102
15	8.2	7.1	6.7	6.4	6.2	5.9	150
10	5.5	4.7	4.5	4.3	4.1	4.0	255
5	2.7	2.4	2.2	2.1	2.1	2.0	↑
3.5	1.9	1.7	1.6	1.5	1.4	1.4	255

model CTW25		Clamping force $F = P / (1.33 + 0.00310 \times LH)$					
Hydraulic pressure MPa	Cylinder force kN	Clamping force kN					Max. arm length Max. LH mm
		Clamp arm length LH mm					
		65	80	100	120	140	
35	26.3	22.9					65
30	22.6	19.6					72
25	18.8	16.3	15.8	Nonusable range			90
20	15.0	13.1	12.7	12.2			119
15	11.3	9.8	9.5	9.1	8.8	8.5	174
10	7.5	6.5	6.3	6.1	5.9	5.7	270
5	3.8	3.3	3.2	3.0	2.9	2.8	↑
3.5	2.6	2.3	2.2	2.1	2.1	2.0	270

Dimensions

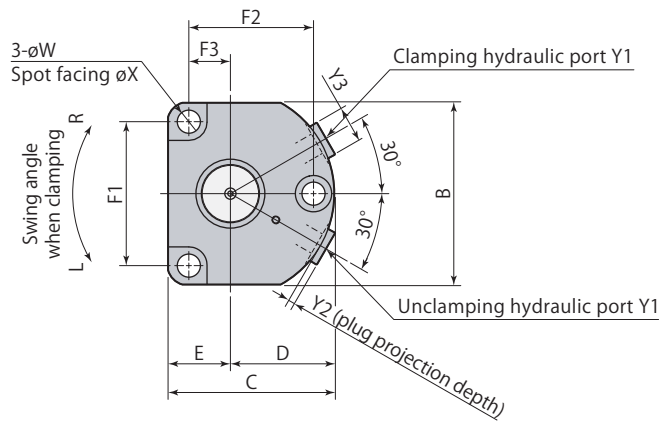

Mounting details

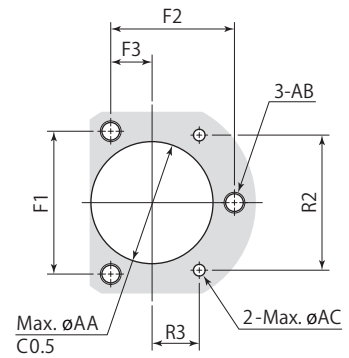

The mounting surface finish must be no rougher than Rz6.3 (ISO4287:1997) for manifold piping.

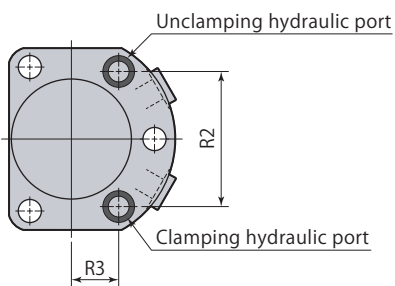
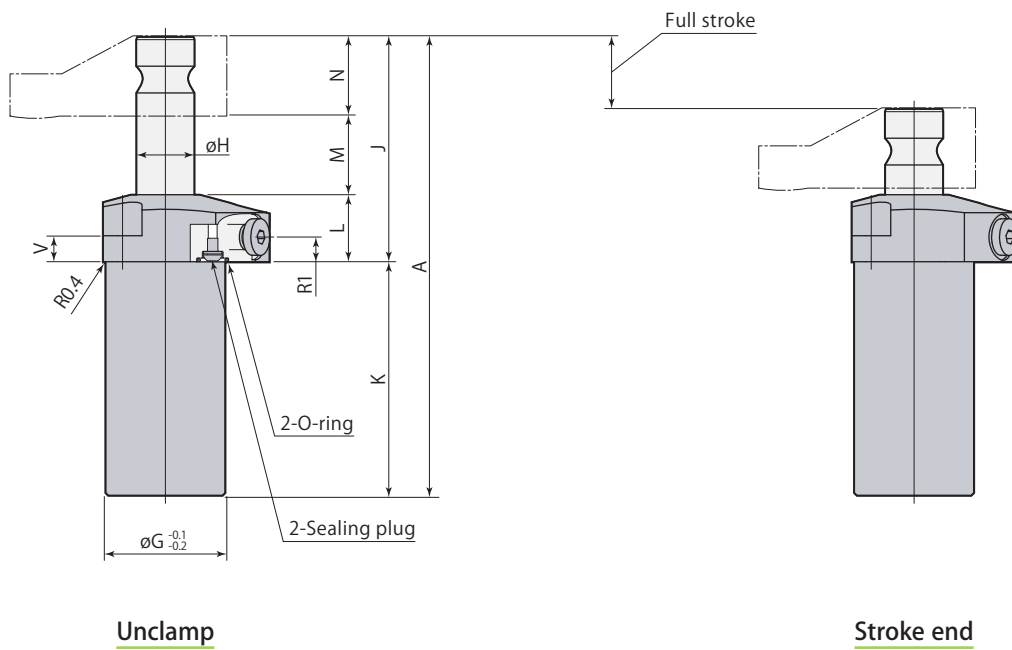

Model	CTW06U-□	CTW10U-□
A	137	176.5
B	56	70
C	50.5	64
D	32.5	40
E	18	24
F1	43.3	55
F2	37.5	47.6
F3	12.5	15.9
øG	33	46
øH	16	22.4
J	71	86.5
K	66	90
L	26	26
M	24	30.5
N	21	30
R1	9.5	9.5
R2	41	52
R3	14.3	18.2
V	13	10
øW	7	8.9
øX	11	14
Y1	G1/8	G1/8
Y2	2.8	2.8
Y3	14	14
O-ring (fluorocarbon hardness Hs90)	P9	P9
øAA	34	47
AB	M6	M8
øAC	7	7
Mass	0.7 kg	1.6 kg
Air bleeding valve	VCE01	VCE01

Refer to each page for the details of options.

- Clamp arm **page → 78** ● Air bleeding valve **page → 46**
- Clamp arm and mounting screws are not included.
- CTW□U-C (Straight, swing angle 0°) is made to order.

Dimensions

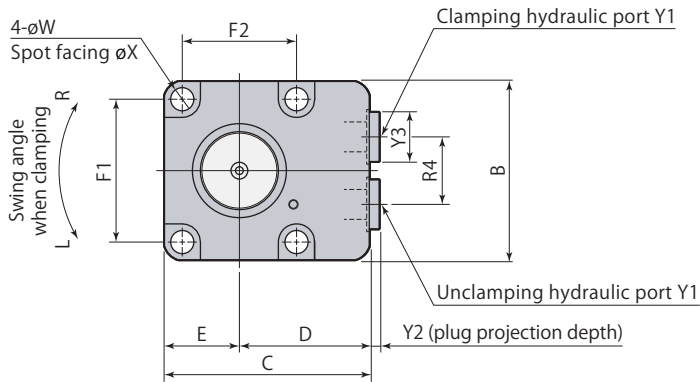

Mounting details

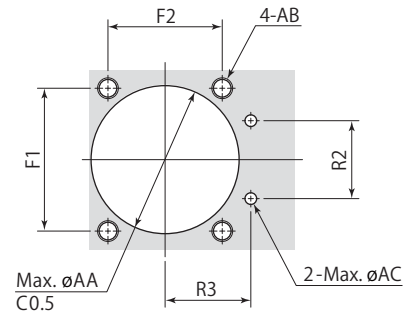

The mounting surface finish must be no rougher than Rz6.3 (ISO4287:1997) for manifold piping.

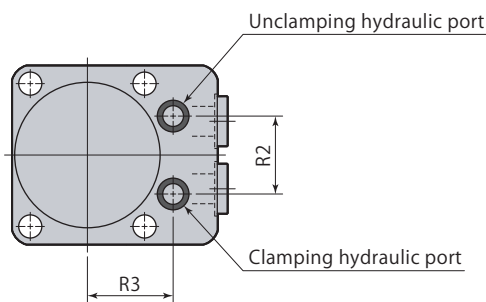
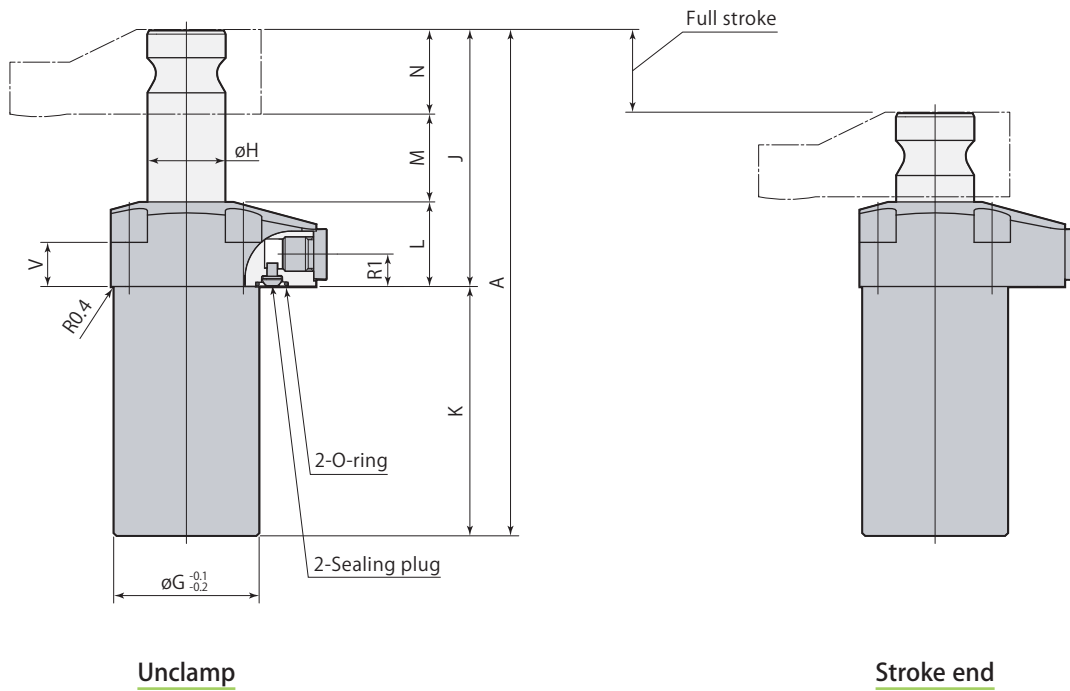

Model	CTW16U-□	CTW25U-□
A	195	226
B	69	69
C	79	87.5
D	50	53
E	29	34.5
F1	55	55
F2	44	55
øG	56	61.5
øH	30	32
J	99	110
K	96	116
L	32	32.5
M	35	42.5
N	32	35
R1	12.5	12.5
R2	30	30
R3	33	36
R4	26	26
V	17	17
øW	8.9	8.9
øX	14	14
Y1	G1/4	G1/4
Y2	4.3	4.3
Y3	19	19
O-ring (fluorocarbon hardness Hs90)	P9	P9
øAA	57	62.5
AB	M8	M8
øAC	7	7
Mass	2.6 kg	3.4 kg
Air bleeding valve	VCE02	VCE02

Refer to each page for the details of options.

- Clamp arm **page → 78** ● Air bleeding valve **page → 46**
- Clamp arm and mounting screws are not included.
- CTW□U-C (Straight, swing angle 0°) is made to order.

Dimensions

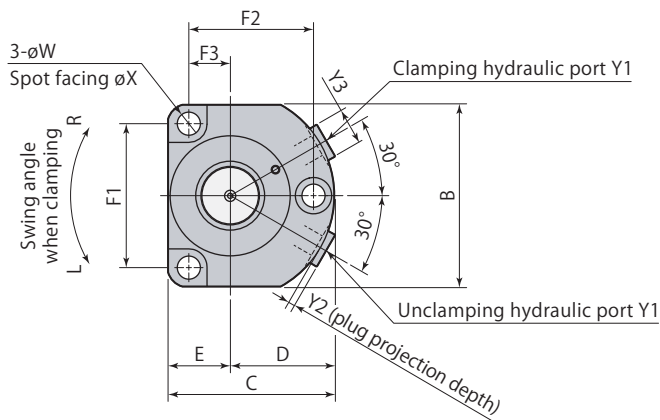

Mounting details

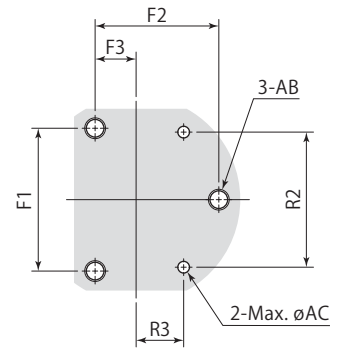

The mounting surface finish must be no rougher than Rz6.3 (ISO4287:1997) for manifold piping.

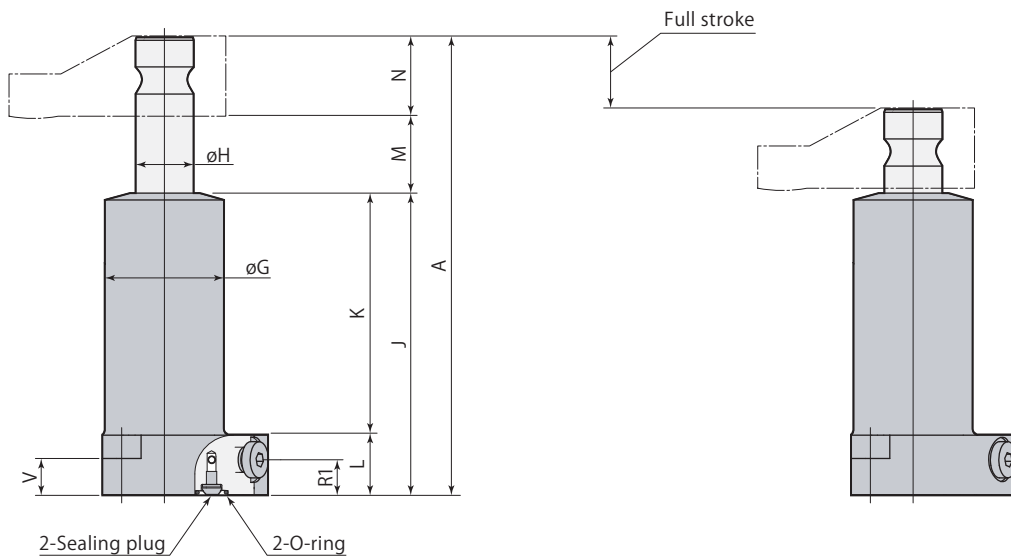

Unclamp

Stroke end

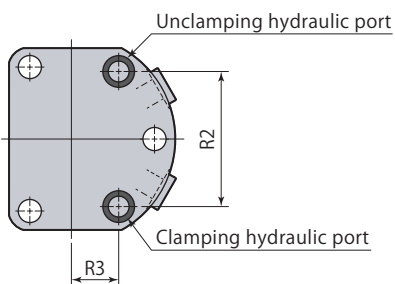

CTW□B-□	Swing clamp Lower flange	35MPa	Double acting
----------------	---------------------------------	--------------	----------------------

Model	CTW06B-□	CTW10B-□	mm
A	137	176.5	
B	56	70	
C	50.5	64	
D	32.5	40	
E	18	24	
F1	43.3	55	
F2	37.5	47.6	
F3	12.5	15.9	
øG	35	46	
øH	16	22.4	
J	92	116	
K	69	93	
L	23	23	
M	24	30.5	
N	21	30	
R1	13.5	13.5	
R2	41	52	
R3	14.3	18.2	
V	16	14	
øW	7	8.9	
øX	11	14	
Y1	G1/8	G1/8	
Y2	2.8	2.8	
Y3	14	14	
O-ring (fluorocarbon hardness Hs90)	P9	P9	
AB	M6	M8	
øAC	7	7	
Mass	0.8 kg	1.6 kg	
Air bleeding valve	VCE01	VCE01	

Refer to each page for the details of options.

- Clamp arm **page → 78**
- Air bleeding valve **page → 46**
- Clamp arm and mounting screws are not included.
- CTW□B-C (Straight, swing angle 0°) is made to order.

Dimensions

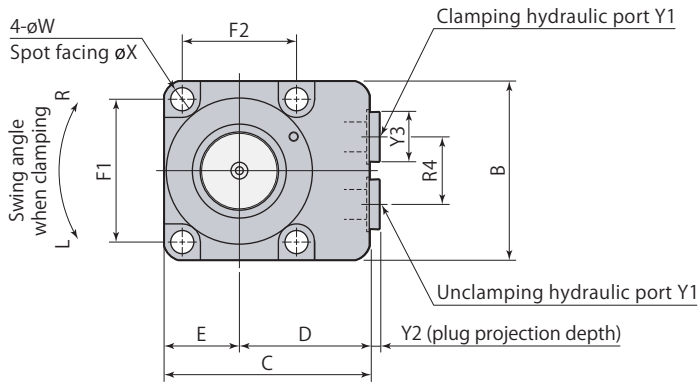

Mounting details

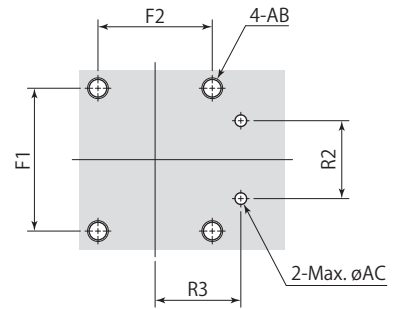

The mounting surface finish must be no rougher than Rz6.3 (ISO4287:1997) for manifold piping.

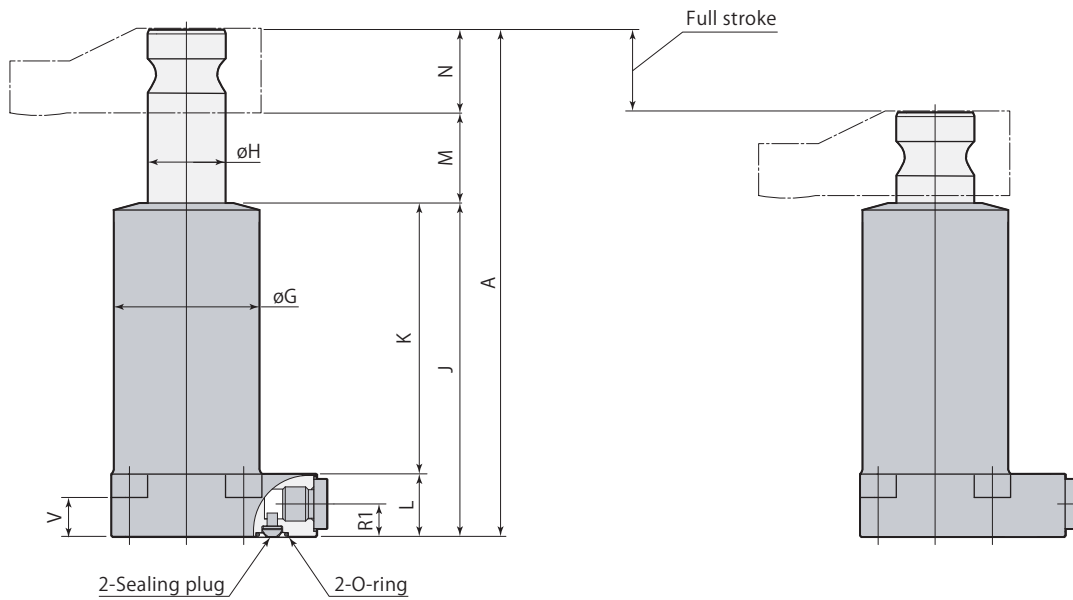

Unclamp

Stroke end

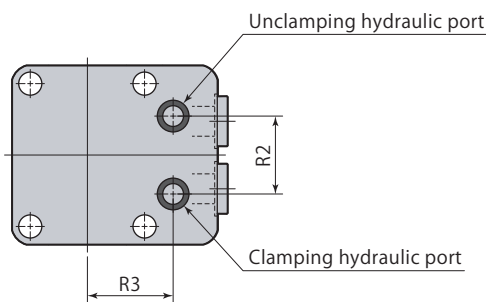

CTW□B-□	Swing clamp Lower flange	35MPa	Double acting
----------------	---------------------------------	--------------	----------------------

Model	CTW16B-□	CTW25B-□	mm
A	195	226	
B	69	69	
C	79	87.5	
D	50	53	
E	29	34.5	
F1	55	55	
F2	44	55	
øG	56	61.5	
øH	30	32	
J	128	148.5	
K	104	124.5	
L	24	24	
M	35	42.5	
N	32	35	
R1	12.5	12.5	
R2	30	30	
R3	33	36	
R4	26	26	
V	15	15	
øW	8.9	8.9	
øX	14	14	
Y1	G1/4	G1/4	
Y2	4.3	4.3	
Y3	19	19	
O-ring (fluorocarbon hardness Hs90)	P9	P9	
AB	M8	M8	
øAC	7	7	
Mass	2.6 kg	3.3 kg	
Air bleeding valve	VCE02	VCE02	

Refer to each page for the details of options.

- Clamp arm **page → 78**
- Air bleeding valve **page → 46**
- Clamp arm and mounting screws are not included.
- CTW□B-C (Straight, swing angle 0°) is made to order.

Dimensions

CTW06, 10 U-□
N30, N45, N60

CTW16, 25 U-□
N30, N45, N60

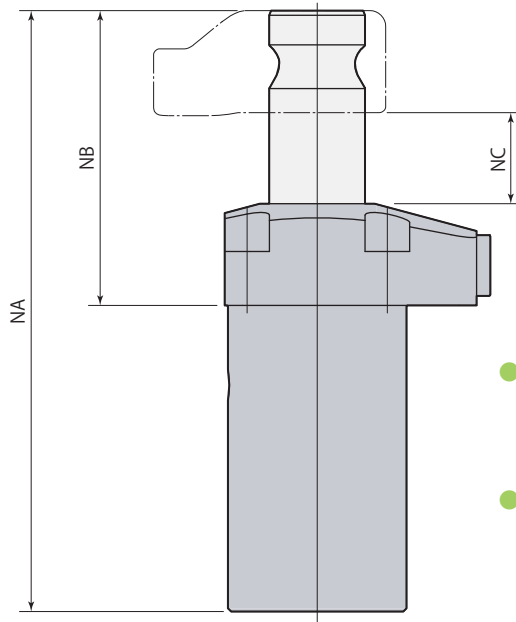
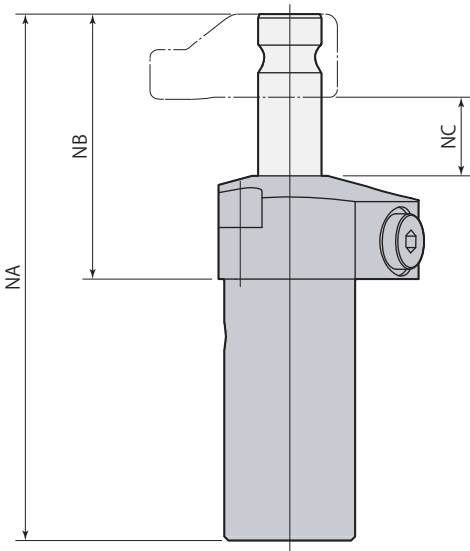
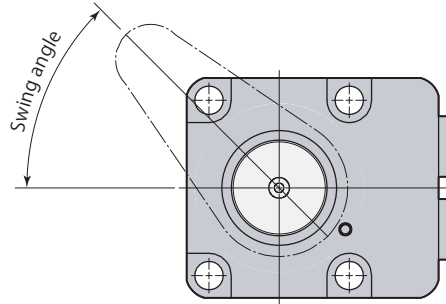
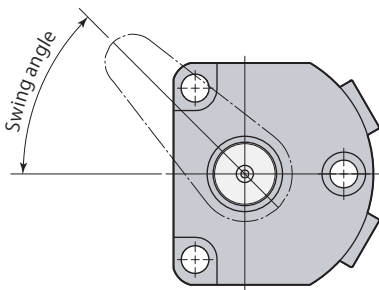

- This diagram indicates unclamped condition of swing direction L (counter-clockwise).
- Refer to **pages** → 54 to 57 for other specifications and dimensions that are not shown in the diagram.
- This product is made to order.

mm

Model	CTW06U-□N□			CTW10U-□N□			CTW16U-□N□			CTW25U-□N□			
Swing angle	30°±5°	45°±5°	60°±5°	30°±5°	45°±5°	60°±5°	30°±5°	45°±5°	60°±5°	30°±5°	45°±5°	60°±5°	
Full stroke	16.5	17.9	19.3	20.7	22.5	24.3	23.3	25.5	27.6	28.0	31.0	34.0	
Swing stroke	6.5	7.9	9.3	7.7	9.5	11.3	9.3	11.5	13.6	12.0	15.0	18.0	
Clamp stroke	10			13			14			16			
Cylinder capacity (cm ³)	Clamp	3.0	3.2	3.5	8.5	9.2	10.0	12.8	14.0	15.2	21.0	23.3	25.5
	Unclamp	6.3	6.8	7.3	16.6	18.1	19.5	29.3	32.0	34.7	43.5	48.2	52.9
NA	131.5	132.9	134.3	169.2	171.0	172.8	186.3	188.5	190.6	214.0	217.0	220.0	
NB	65.5	66.9	68.3	79.2	81.0	82.8	90.3	92.5	94.6	98.0	101.0	104.0	
NC	18.5	19.9	21.3	23.2	25.0	26.8	26.3	28.5	30.6	30.5	33.5	36.5	

Dimensions

CTW06, 10 B-□
N30, N45, N60

CTW16, 25 B-□
N30, N45, N60

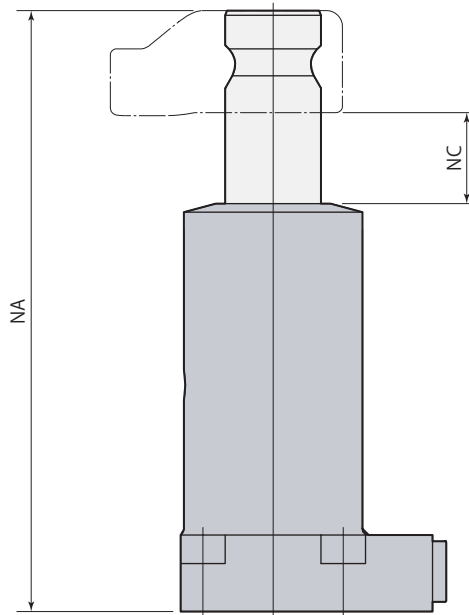
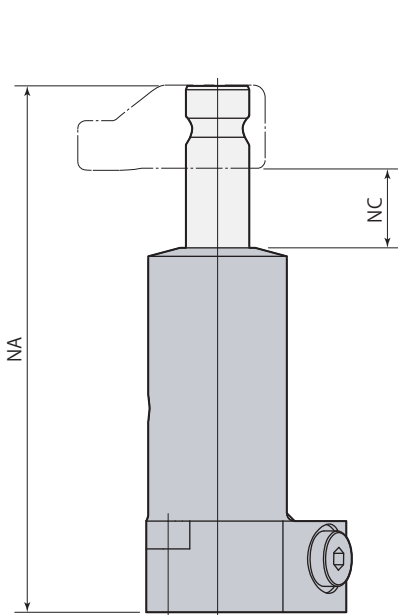
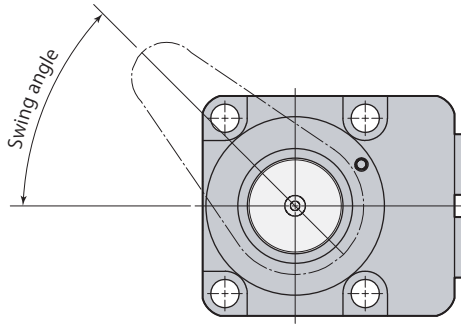
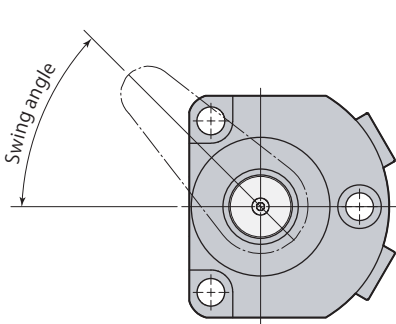

- This diagram indicates unclamped condition of swing direction L (counter-clockwise).
- Refer to **pages → 58 to 61** for other specifications and dimensions that are not shown in the diagram.
- This product is made to order.

mm

Model		CTW06B-□N□			CTW10B-□N□			CTW16B-□N□			CTW25B-□N□		
Swing angle		30°±5°	45°±5°	60°±5°	30°±5°	45°±5°	60°±5°	30°±5°	45°±5°	60°±5°	30°±5°	45°±5°	60°±5°
Full stroke		16.5	17.9	19.3	20.7	22.5	24.3	23.3	25.5	27.6	28.0	31.0	34.0
Swing stroke		6.5	7.9	9.3	7.7	9.5	11.3	9.3	11.5	13.6	12.0	15.0	18.0
Clamp stroke		10			13			14			16		
Cylinder capacity (cm ³)	Clamp	3.0	3.2	3.5	8.5	9.2	10.0	12.8	14.0	15.2	21.0	23.3	25.5
	Unclamp	6.3	6.8	7.3	16.6	18.1	19.5	29.3	32.0	34.73	43.5	48.2	52.9
NA		131.5	132.9	134.3	169.2	171.0	172.8	186.3	188.5	190.6	214.0	217.0	220.0
NC		18.5	19.9	21.3	23.2	25.0	26.8	26.3	28.5	30.6	30.5	33.5	36.5

W1 Clamp arm

W2 Clamp arm

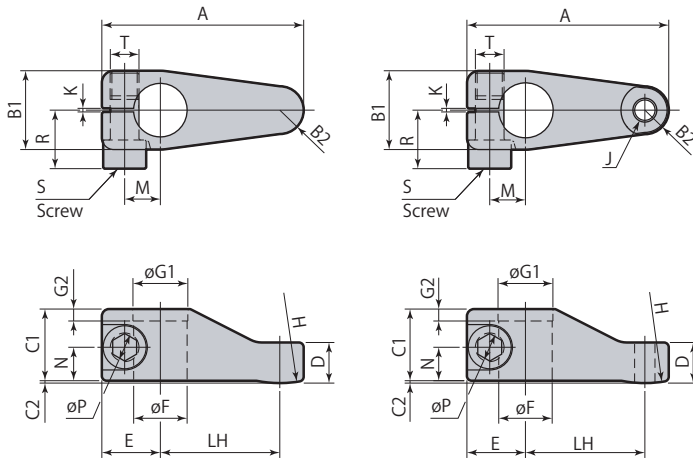

Material : SCM440 (Refining HB285-344)

WL Clamp arm

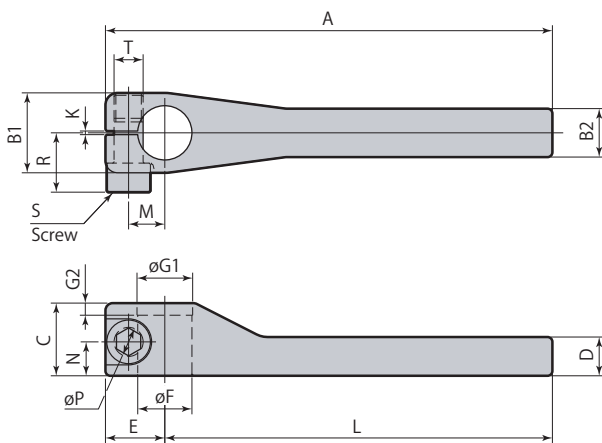

Material : SCM440 (Refining HB285-344)

Screw

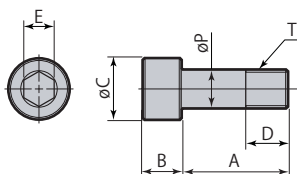

mm

Clamp arm	CTH06-W□	CTH10-W□	CTH16-W□	CTH25-W□
A	64.5	84.5	98	113
B1	24	33	43	49
B2	7	10	11	15
C1	21	30	32	35
C2	0.5	1	1	1.5
D	12.5	17	21	21.5
E	17.5	24.5	30	33
øF	16 ^{+0.003} _{-0.015}	22.4 ^{+0.004} _{-0.017}	30 ^{+0.004} _{-0.017}	32 ^{+0.005} _{-0.020}
øG1	-	23	-	33
G2	-	5	-	6
H	50	50	60	75
J	M8×1.25	M10×1.5	M10×1.5	M12×1.75
K	2	2	2	2
LH	40	50	57	65
M	10.5±0.1	15±0.1	19±0.1	20.5±0.1
N	10	14	15	16
øP	8 ^{+0.015} ₀	12 ^{+0.018} ₀	14 ^{+0.018} ₀	16 ^{+0.018} ₀
R	16.5	24.5	29.5	34.5
S (screw)	CTH06-VB	CTH10-VB	CTH16-VB	CTH25-VB
T	M8×1.0	M12×1.5	M14×1.5	M16×1.5
Mass	0.13 kg	0.33 kg	0.52 kg	0.78 kg
Swing clamp	CTW06 CTV06	CTW10 CTV10	CTW16 CTV16	CTW25 CTV25

mm

Clamp arm	CTH06-WL	CTH10-WL	CTH16-WL	CTH25-WL
A	152.5	184.5	200	213
B1	24	33	43	49
B2	14	20	22	30
C	21	30	32	35
D	12	16	20	20
E	17.5	24.5	30	33
øF	16 ^{+0.003} _{-0.015}	22.4 ^{+0.004} _{-0.017}	30 ^{+0.004} _{-0.017}	32 ^{+0.005} _{-0.020}
øG1	-	23	-	33
G2	-	5	-	6
K	2	2	2	2
L	135	160	170	180
M	10.5±0.1	15±0.1	19±0.1	20.5±0.1
N	10	14	15	16
øP	8 ^{+0.015} ₀	12 ^{+0.018} ₀	14 ^{+0.018} ₀	16 ^{+0.018} ₀
R	16.5	24.5	29.5	34.5
S (screw)	CTH06-VB	CTH10-VB	CTH16-VB	CTH25-VB
T	M8×1.0	M12×1.5	M14×1.5	M16×1.5
Mass	0.24 kg	0.58 kg	0.87 kg	1.25 kg
Swing clamp	CTW06 CTV06	CTW10 CTV10	CTW16 CTV16	CTW25 CTV25

mm

Screw	CTH06-VB	CTH10-VB	CTH16-VB	CTH25-VB
A	20	28	35	41
B	8	12	14	16
øC	13	18	21	24
D	9	11	13	15
E	6	10	12	14
øP	8 ^{-0.01} _{-0.05}	12 ^{-0.01} _{-0.05}	14 ^{-0.01} _{-0.05}	16 ^{-0.01} _{-0.05}
T	M8×1.0	M12×1.5	M14×1.5	M16×1.5
Swing clamp	CTW06 CTV06	CTW10 CTV10	CTW16 CTV16	CTW25 CTV25

Refer to diagram shown below for shape and dimensions of mounting portion.

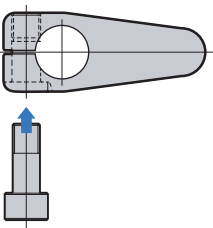
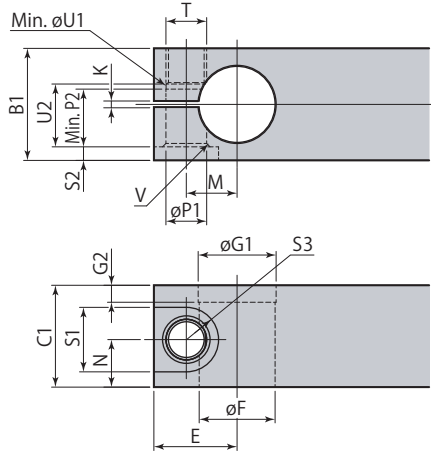

● Install mounting screws for arm from direction shown in left diagram viewed from top. Installation from the opposite direction can cause loosened screws and resultant broken rod.

Swing clamp	CTW06 CTV06	CTW10 CTV10	CTW16 CTV16	CTW25 CTV25
B1	24	33	43	49
C1	21	30	32	35
E	17.5	24.5	30	33
øF	16 ^{+0.003} _{-0.015}	22.4 ^{+0.004} _{-0.017}	30 ^{+0.004} _{-0.017}	32 ^{+0.005} _{-0.020}
øG1	—	23	—	33
G2	—	5	—	6
K	2	2	2	2
M	10.5±0.1	15±0.1	19±0.1	20.5±0.1
N	10	14	15	16
øP1	8 ^{+0.015} ₀	12 ^{+0.018} ₀	14 ^{+0.018} ₀	16 ^{+0.018} ₀
P2	11	17	22	26
S1	14	19	22	25
S2	3.5	4	6	6
S3	7	9.5	11	12.5
T	M8×1.0	M12×1.5	M14×1.5	M16×1.5
øU1	7.9	11.9	13.9	15.9
U2	12.5	18.5	23.5	27.5
V	C1	C1	C1.5	C1.5

Caution in use

Mounting & dismounting of clamp arm

Swing clamp may be damaged if excessive torque is applied to piston rod, since structure is intended for swinging using cam mechanism with lead grooves.

Loosen screw (CTH□-VB) before mounting or dismounting clamp arm, or adjusting position of clamp arm, to prevent excessive rotating torque from being applied on piston rod.

Refer to table below for screw tightening torque.

Clamp models	Thread size	Tightening torque
CTW06, CTV06	M 8	30 N·m
CTW10, CTV10	M12	100 N·m
CTW16, CTV16	M14	150 N·m
CTW25, CTV25	M16	240 N·m

Swing speed adjustment

Too fast swinging speed of clamp arm can cause malfunction. Adjust speed using flow control valve with check valve to set the swing time equal to or higher than the shortest swing time shown in the table below. Clamp stroke (perpendicular descend) time is not included in 90° swing time.

Clamp models	Shortest swing time	Max. flow rate	
		Clamping side	Unclamping side
CTW06, CTV06	0.3 s	0.43 L/min	0.91 L/min*
CTW10, CTV10	0.3 s	1.23 L/min	2.41 L/min*
CTW16, CTV16	0.4 s	1.48 L/min	3.39 L/min*
CTW25, CTV25	0.4 s	2.70 L/min	5.60 L/min*

* : Only for the double-acting model CTW

Moment of inertia for clamp arm

Too large moment of inertia for clamp arm can also cause malfunction. When fabricating the clamp arm, determine a proper shape which provides moment of inertia smaller than the maximum moment of inertia shown in the table below.

Clamp models	Max. moment of inertia
CTW06, CTV06	1.6×10 ⁻³ kg·m ²
CTW10, CTV10	5.1×10 ⁻³ kg·m ²
CTW16, CTV16	8.5×10 ⁻³ kg·m ²
CTW25, CTV25	1.4×10 ⁻² kg·m ²

Moment of inertia for option clamp arm (reference)

Clamp arm models		Moment of inertia
Standard type	CTH06-W1, CTH06-W2	6.1×10 ⁻⁵ kg·m ²
	CTH10-W1, CTH10-W2	2.6×10 ⁻⁴ kg·m ²
	CTH16-W1, CTH16-W2	5.5×10 ⁻⁴ kg·m ²
	CTH25-W1, CTH25-W2	1.14×10 ⁻³ kg·m ²
Long type	CTH06-WL	1.1×10 ⁻³ kg·m ²
	CTH10-WL	3.5×10 ⁻³ kg·m ²
	CTH16-WL	5.8×10 ⁻³ kg·m ²
	CTH25-WL	9.5×10 ⁻³ kg·m ²